



C34

Chirurgie
Surgery
Cirugía
Chirurgie
Chirurgia

Chirurgische Instrumente



Seit 1923



Surgical Innovation is our passion



Chirurgische Innovation

ist unsere Leidenschaft

Wie kommt man dazu, über 16.000 chirurgische Instrumente zu entwickeln, zu fertigen und zu vermarkten? Produkte, die sich durch klare Alleinstellungsmerkmale auszeichnen. Es ist die Leidenschaft, neue Wege zu finden, die Menschen helfen und der Gesundheit dienen.



GB Surgical Innovation is our passion

What is the secret behind the development, manufacture and distribution of over 16,000 exclusive surgical instruments, products whose distinguishing characteristics truly set them apart from all the others? The answer is passion, the overwhelming desire to discover new ways of serving humankind in its search for ultimate health.

ES La innovación quirúrgica es nuestra pasión

¿Cómo es posible concebir, producir y comercializar más de 16.000 instrumentos quirúrgicos? Estamos hablando de productos que se caracterizan por unas propiedades exclusivas, claramente definidas. La clave está en que nos motiva la pasión por encontrar nuevos caminos para ayudar a las personas y fomentar la salud.

F Notre passion est l'innovation chirurgicale

Comment est-il possible de développer, fabriquer et commercialiser plus de 16 000 instruments chirurgicaux ? Des produits dont les caractéristiques distinctives sont leur position unique sur le marché. Et bien, ceci est en fait dû à la passion de vouloir trouver de nouvelles méthodes afin de venir en aide aux personnes et de servir la santé.

I L'innovazione nella chirurgia è la nostra passione

Che cosa ci spinge a progettare, produrre e distribuire più di 16.000 strumenti chirurgici dalle caratteristiche uniche? Sono la nostra passione e il desiderio di aiutare il prossimo e cercare nuove vie per migliorare la salute.



Am Anfang stand die Vision, aus kleinen Firmen eine international agierende Unternehmensgruppe zu bilden. Das war 1923. Heute beschäftigt die KLS Martin Group über 1000 Mitarbeiter und ist einer der weltweit führenden Konzerne für Entwicklung, Produktion und Vertrieb medizintechnischer Produkte, die in enger Zusammenarbeit mit denjenigen entwickelt werden, die sie letztlich einsetzen: den Chirurgen.

GB

In the beginning there was a vision

Our vision, in 1923, was to create an internationally operating group of companies from a handful of smaller businesses. Today, the KLS Martin Group has a staff of over 1000 and is one of the leading globally acting enterprises for the development, manufacture and distribution of medical devices. We work hand in hand with those holding the scalpel: the surgeon.

ES

Todo comienzo parte de una visión

Al principio la visión consistía en conformar, a partir de pequeñas empresas, un grupo empresarial con intervención a escala mundial. Corría el año 1923 en aquel entonces. Hoy en día, el KLS Martin Group da trabajo a más de 1000 personas y se encuentra a nivel mundial entre los consorcios líderes dedicados al desarrollo, producción y comercialización de productos medicotécnicos, diseñados en estrecha colaboración con aquel grupo de personas que finalmente los emplean: los cirujanos.

F

Tout commença par une vision

Au début, en l'an 1923, naquit la vision de pouvoir former un groupe d'entreprises à activités internationales à partir de petites entreprises. Le groupe KLS Martin Group occupe actuellement plus de 1000 employés et il est l'un des groupes leaders sur le marché mondial dans le secteur du développement, de la production et de la commercialisation de produits médico-techniques, ces produits ayant été développés en étroite collaboration avec ceux les utilisant, c'est-à-dire les chirurgiens.

I

All'inizio c'era una visione

All'inizio c'era una visione: fondere piccole ditte per creare un gruppo aziendale operante a livello internazionale. Era il 1923. Oggi il KLS Martin Group ha più di 1000 dipendenti ed è una delle imprese leader al mondo nella progettazione, produzione e distribuzione di prodotti medicali creati in stretta collaborazione con gli utenti finali: i chirurghi.

Am Anfang
stand eine Vision





Qualitätssicherung ohne Kompromisse

Unsere Produkte erfüllen den Anspruch anwendungsbezogener Funktionalität, intelligenter Handhabung und hoher Qualität. Und wenn es um die Erfüllung dieses Anspruchs geht, machen wir keine Kompromisse. Um dies zu gewährleisten, unterhält KLS Martin ein eigenes hochmodernes Labor sowie ein Technikum, in denen die Qualität unserer Erzeugnisse – auch unter extremen Bedingungen – auf „Herz und Nieren“ getestet und dokumentiert werden.

GB

Quality assurance uncompromising

Our products are designed to consistently meet high demands for application-oriented functionality, intelligent operation and top quality. And we are not prepared to compromise when it comes to meeting the justified expectations of our customers, present and future – your standards become ours. KLS Martin runs their own ultramodern laboratories and a pilot plant, where our products are stress-tested under extreme conditions – every step is documented before release.

ES

Un seguro de calidad sin compromisos

Nuestros productos cumplen el requisito de estar dotados de la funcionalidad conforme a su aplicación, su manipulación es inteligente y son de alta calidad. No transigimos a la hora de cumplir con estas condiciones esenciales. Por este motivo, KLS Martin mantiene un laboratorio propio, altamente moderno, así como una escuela técnica, donde se ensaya y documenta la calidad de nuestros productos – inclusive bajo condiciones extremas –, examinándolos “hasta la médula”.

F

Une assurance qualité sans compromis

Nos produits répondent aux exigences requises par une fonctionnalité relative à l'application, un maniement intelligent et une qualité élevée. Et nous n'acceptons aucun compromis lorsqu'il s'agit de répondre à ces exigences. KLS Martin possède à ce but son propre laboratoire ultramoderne et son centre technique dans lesquels la qualité de nos produits fabriqués est testée minutieusement – même sous des extrêmes conditions – et les résultats des tests sont documentés.

I

Assicurazione della qualità senza compromessi

I nostri prodotti sono stati progettati guardando alle esigenze della prassi applicativa, offrono una manipolazione intelligente e sono di qualità elevata. A tale riguardo non facciamo compromessi. Per garantire questo standard, KLS Martin ha un laboratorio altamente moderno e un centro tecnologico in cui controlla e documenta la qualità di tutti i prodotti, anche in condizioni estreme.

Wir setzen Standards

für die Instrumentenaufbereitung

Wie lassen sich Medizinprodukte vor mechanischer, thermischer oder chemischer Belastung schützen? Was muss man bei der Aufbereitung und Pflege besonders feingliedriger Mikrochirurgieinstrumente berücksichtigen? Als Mitglied wichtiger Gremien und Arbeitskreise – wie z. B. dem Arbeitskreis Instrumenten-Aufbereitung AKI – gibt KLS Martin Antworten und erarbeitet Lösungen für die optimale Aufbereitung und Pflege von Instrumenten. Von der Auswahl angemessener Reinigungsverfahren bis hin zu Sterilisationsverfahren.

GB

Standards and best practice: instrument preparation

How best to protect surgical instruments from mechanical, thermal and chemical stresses? What steps are performed to ensure optimal preparation and care of highly delicate microsurgical instruments? KLS Martin, in their capacity as member of important advisory boards and working groups – for example, Working Group Instrument Preparation AKI – is in a position to provide answers and solutions to all inquiries with regard to the optimal preparation and care of instruments, ranging from knowledgeable advice on appropriate cleaning methods through sterilization processes.

ES

Los estándares y la mejor práctica para la preparación de instrumentos

¿Cómo se pueden proteger los productos médicos contra la actuación de factores mecánicos, térmicos y químicos? ¿Qué es lo que hay que considerar en el momento de preparación y cuidado del instrumental microquirúrgico, constituido fundamentalmente por componentes finos? En función de miembro de asociaciones y comités laborales importantes – como por ejemplo, el Comité Alemán de Trabajo de Preparación de Instrumental AKI – KLS Martin ofrece respuestas y elabora soluciones para el tratamiento y cuidado óptimos del instrumental. Éstas abarcan desde la selección de métodos de limpieza adecuados hasta el procedimiento de esterilización.

F

Normes et pratiques idéales pour la préparation des instruments

Comment protéger les produits médicaux contre d'éventuelles contraintes mécaniques, thermiques ou chimiques? Quels points doivent être pris en considération pour le traitement et l'entretien d'instruments micro-chirurgicaux à fine ossature? A titre de membre d'importants organismes et cercles de travail, tels que par exemple l'AKI (Arbeitskreis Instrumenten-Aufbereitung = cercle de travail pour le traitement des instruments), KLS Martin donne des réponses et élabore des solutions pour assurer un traitement et un entretien optimaux des instruments. Depuis la sélection de procédés de nettoyage adéquats jusqu'au procédé de stérilisation.

I

Standard e “best practice” per la preparazione degli strumenti

Come si possono proteggere gli strumenti medici da agenti aggressivi di tipo meccanico, termico o chimico? Cosa occorre tenere presente nella preparazione e nella manutenzione di strumenti microchirurgici particolarmente delicati? Quale membro di importanti organi e gruppi di lavoro, come ad esempio AKI, il gruppo tedesco di lavoro per la corretta preparazione degli strumenti, KLS Martin dà risposta e sviluppa soluzioni per la preparazione e la manutenzione ottimali degli strumenti, dalla scelta dei sistemi di pulizia più idonei alle procedure di sterilizzazione.





Lebenslange Garantie
für MARTIN-Instrumente



Lebenslange Garantie – wann immer Sie sie brauchen

Keine Frage, wir sind stets auf der Suche nach der noch besseren Lösung. Das zeichnet den kontinuierlichen Fortschritt in unserem Produktportfolio aus. Gleichwohl sind alle unsere Instrumente qualitativ erstklassig und werden höchsten Ansprüchen gerecht. Und weil wir davon überzeugt sind, gewähren wir auf jedes Instrument bei sach- und fachgerechtem Einsatz eine lebenslange Garantie.

GB

Whenever you need it –
our lifetime guarantee

Our determined and ongoing search for the perfect solution is reflected in the dynamic nature of our product portfolio. You simply will not find better instruments on the market. And because we truly believe in the outstanding quality of our products, we offer a lifelong guarantee on each instrument, in connection with appropriate and professional use.

ES

Necesite lo que necesite –
la garantía es de por vida

Lo cierto es que siempre estamos en la búsqueda de una solución que sea aún mejor. Esto es lo que determina el progreso continuado de nuestra cartera de producción. Todos nuestros instrumentos son de la misma calidad máxima cumpliendo, por lo tanto cumplen con los requisitos más exigentes. Y como estamos convencidos de ello, garantizamos en todo nuestro instrumental una garantía de por vida, siempre y cuando se utilice como es debido y según las normativas.

F

Si jamais vous en
avez besoin – notre
garantie à vie

Nous sommes, sans aucun doute, toujours à la recherche de la solution optimale. Ce fait caractérise le progrès continu dans notre porte-feuille de produits. Tous nos instruments sont à la fois de toute première qualité et conformes à des exigences maximales. Et étant donné ce fait, nous garantissons sur chaque instrument une garantie à vie, à condition que les instruments soient utilisés de manière adéquate et compétente.

I

Ogni qual volta ne avete
bisogno – la nostra garanzia
a vita

Essendo alla ricerca di soluzioni sempre migliori, i nostri prodotti vengono costantemente migliorati. Essi sono di qualità eccellente e soddisfano persino le esigenze più elevate. Per questo possiamo accordare una garanzia a vita per ogni strumento impiegato in modo appropriato e corretto.

Instrumente schneller finden – die Katalog-Handhabung

Es ist ganz einfach: Die Artikelnummer gibt Auskunft über Produkt, Produktgruppe und Größe/Figur des Instruments. Jedes Produkt wird in Größe und Funktion vollständig beschrieben sowie maßstabsgetreu abgebildet – die Arbeitsenden je im Verhältnis 1 : 1. So finden Sie schneller, was Sie wirklich brauchen.

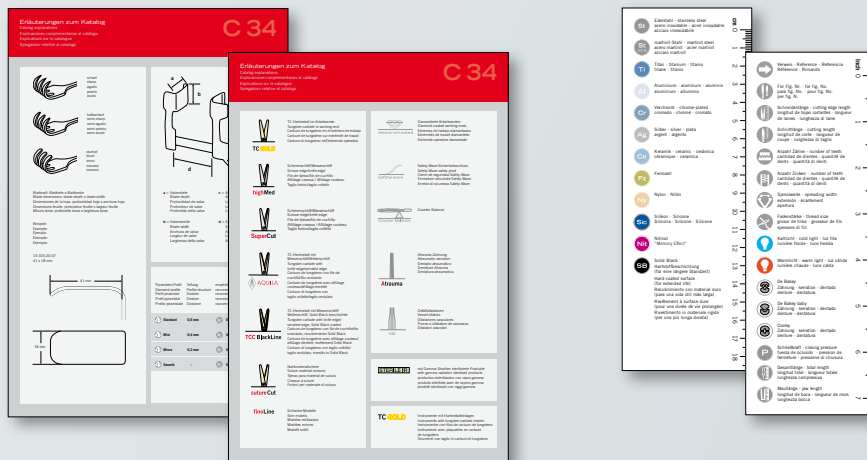

GB

Finding the instruments you need – how to use the catalogue

Straightforward and easy: The article number informs you about the product, product group and instrument size. Size and function of each product are described in full detail and illustrated to scale – the working ends in a ratio of 1 : 1. You can quickly find exactly what you are looking for.

ES

Encuentre el instrumental que necesita – Modo de consultar el catálogo

Es muy simple: El número de artículo facilita una información acerca del producto, el grupo de producto y el tamaño del instrumental. Encontrará la descripción completa de tamaño y función de cada producto y una ilustración a escala; los extremos funcionales aparecerán en relación 1 : 1. Así Ud. podrá encontrar más rápidamente lo que realmente necesita.

F

Comment trouver les instruments requis – l'utilisation du catalogue

C'est tout simple : le numéro d'article fournit des informations sur le produit, le groupe de produits et la taille de l'instrument. Une description détaillée de la taille et du fonctionnement de chaque produit est fournie et tous les produits sont illustrés à l'échelle – les extrémités des instruments étant illustrées au rapport 1 : 1. Ainsi vous trouvez plus rapidement ce dont vous avez vraiment besoin.

I

Trovare gli strumenti che cercate – I cataloghi

È semplicissimo: il codice articolo fornisce informazioni sul prodotto, sulla categoria e sulla grandezza dello strumento. Il catalogo presenta una descrizione dettagliata di ciascun prodotto, delle sue dimensioni e funzioni nonché un'illustrazione in scala degli strumenti, le cui estremità sono riprodotte in rapporto 1 : 1. In questo modo trovate più velocemente ciò di cui avete veramente bisogno.

Abbildungsmaßstab
Illustration scale
Los productos en escala
Produits à l'échelle
Prodotti dimensioni



11-339-12-07
12,5 cm / 5"
feines Modell
fine pattern
modelo fino
modèle fin
modello delicato



11-339-18-07
18 cm / 7"
feines Modell
fine pattern
modelo fino
modèle fin
modello delicato

Arbeitsenden
Working end
El extremo funcional
del producto
Extrémité opératoire
du produit
L'estremità funzionale
del prodotto

Autor (wenn vorhanden)
Author (if available)
Autor (si lo hay)
Auteur (s'il existe)
Autore (se disponibile)

Salyer
11-339-12-07 –
11-339-18-07

Angaben zum Produkt
Product information
Datos sobre el producto
Données sur le produit
Indicazioni relative al
prodotto

für Lippen-, Kiefer-, Gaumenspalte
for Cleft Palate
para fisura paladar
pour fente du palais
per cheilo-labbro-palato schisi

Maße
Dimensions
Dimensiones
Dimensions
Dimensioni









	Materialart	Material type	Tipo de material	Type de matériau	Tipo di materiale
01	Stahl 18/8 martinit, antimagnetisch, rostfrei, säurebeständig	steel 18/8 martinit, antimagnetic, stainless, acid-resistant	acero 18/8 martinit, antimagnético, inoxidable, resistente a los ácidos	acier 18/8 martinit, antimagnétique, inoxydable, résistant aux acides	acciaio 18/8 martinit, antimagnetico, inossidabile, resistente agli acidi
02	verchromt	chrome-plated	cromado	chromé	cromato
04	alle übrigen, nicht besonders gekennzeichneten Materialarten	all other, not specially marked material types	todos los otros tipos de materiales no identificados de forma especial	tous les autres types de matériau sans marquage spécial	tutti gli altri tipi di materiali senza marcatura speciale
07	rostfreier Stahl	stainless steel	acero inoxidable	acier inoxydable	acciaio inossidabile
08	Silber	silver	plata	argent	argento
09	Titan	titanium	titanio	titane	titanio
14	Solid Black	Solid Black	Solid Black	Solid Black	Solid Black
98	Ersatzteil	Replacement part	Pieza de repuesto	Pièce de rechange	Pezzo di ricambio

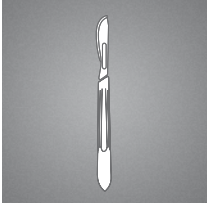
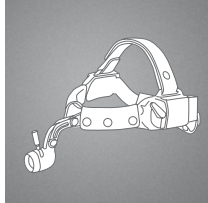

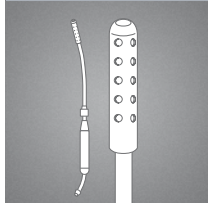

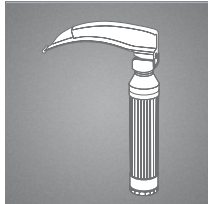
Übersichtstafel
Table of Contents
Tabla de catálogo
Contenu
Indice di catalogo

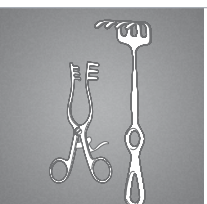
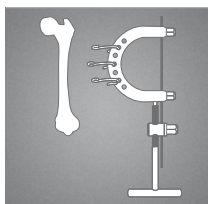
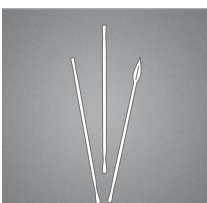
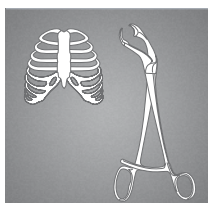

Übersichtstafel

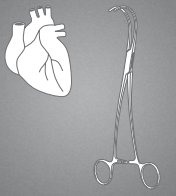
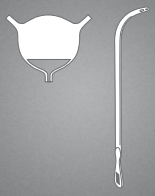
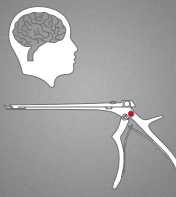
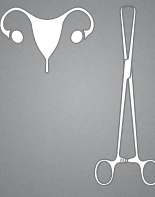
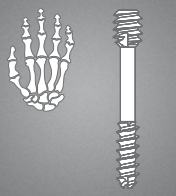
Table of Contents
Tabla de catálogo
Contenu
Indice di catalogo

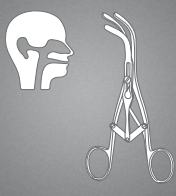
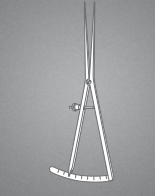
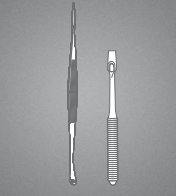
10 1-17		Skalpelle Scalpels Bisturíes Bistouris Bisturi	17 353-355		Diagnostik Diagnostics Diagnóstico Diagnostic Diagnostica
11 19-135		Scheren Scissors Tijeras Ciseaux Forbici	18 357-384		Trokare, Sauger, Kanülen Trocars, Suction Tubes, Cannulas Trócares, Tubos de Aspiración, Cánulas Trocarts, Tubes d'aspiration, Canules Trequarti, Tubi d'aspirazione, Cannule
12 137-170		Pinzetten Forceps Pinzas Pincés Pinze	19 385-400		Narkose Anaesthesia Anestesia Anesthésie Anestesia
13 171-230		Arterienklemmen Artery Forceps Pinzas hemostáticas Pincés hémostatiques Pinze emostatiche	20 401-447		Naht Suture Sutura Suture Sutura
14 231-237		Tupfer- und Kornzangen Cotton Swap Forceps etc. Pinzas para tapones y curaciones Pincés à tampons et à pansements Pinze per tamponi e per medicazione	21 449-458		Verband Dressings Vendajes Pansements Bendaggi
15 239-344		Wundhaken Retractors Separadores Ecarteurs Divaricatori	22 459-461		Knochenchirurgie* Bone Surgery* Cirugía ósea* Chirurgie osseuse* Chirurgia ossea*
16 345-352		Sondens, Watteträger, Spatel Probes, Applicators, Spatulas Sondas, Porta-algodones, Espátulas Sondes, porte-cotons, spatules Sonde, portacotoni, spatole	23 463-549		Knochenchirurgie* Bone Surgery* Cirugía ósea* Chirurgie osseuse* Chirurgia ossea*

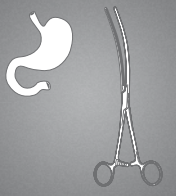
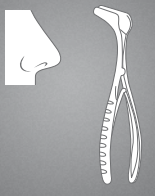
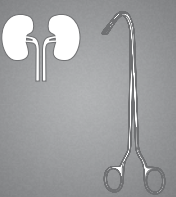
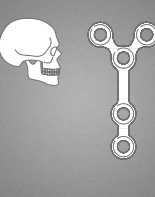
24 551-677		Herz-, Thorax- und Gefäßchirurgie* Cardio Thoracic and Vascular Surgery* Cirugía cardíaca, torácica y vascular* Chirurgie cardiaque, thoracique et vasculaire* Chirurgia cardiaca, toracica e vascolare*	31 785-795		Urologie Urology Urología Urologie Urologia
24 679-733		Neurochirurgie* Neurosurgery* Neurocirugía* Neurochirurgie* Neurochirurgia*	32 797-835		Gynäkologie Gynecology Ginecología Gynécologie Ginecologia
25 26 735-737		Implantat-Systeme CMF und Trauma* Implant Systems CMF and Trauma* Sistemas de implantes CMF y Trauma* Systèmes d'implant CMF et Trauma* Sistemi di impianto CMF e Trauma*	33 837-842		Geburtshilfe Obstetrics Obstetricia Obstétrique Ostetricia
27 739-742		Tracheotomie Tracheotomy Traqueotomía Trachéotomie Tracheotomia	35 843-845		Messzirkel Calipers Compases Compas Compassi
28 743-748		Kropfchirurgie, Dermatologie Goitre, Dermatology Bocio, Dermatología Goitre, Dermatologie Gozzo, Dermatologia	36 847-888		Otologie Otology Otología Otologie Otologia
30 749-777		Magen, Darm, Rektum Stomach, Intestines, Rectum Estómago, Intestinos, Recto Estomac, Intestins, Rectum Stomaco, Intestini, Retto	37 889-926		Rhinologie RhinoLOGY Rinología Rhinologie Rinologia
31 779-784		Leber, Galle, Niere Liver, Gall bladder, Kidney Higado, Biliares, Renales Foie, Biliaire, Rénaux Fegato, Biliari, Renali	38 927-928 48 50		Mund-, Kiefer-, Gesichtschirurgie* Oral Maxillo-Facial Surgery* Cirugía oral y maxilofacial* Chirurgie buccale et maxillo-faciale* Chirurgia buccale e maxillo-facciale*

Übersichtstafel

Table of Contents
Tabla de catálogo
Contenu
Indice di catalogo

39
931-942

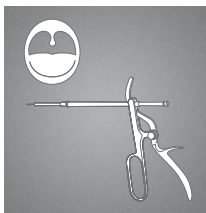

Tonsillektomie, Laryngo-Bronchoskopie
Tonsillectomy, Laryngo-Bronchoscopy
Tonsilectomía, Laringo-Bronchoscopia
Tonsillectomie, Laryngo-Bronchoscopie
Tonsilectomia, Laringo-Bronchoscofia

40
-47
943-945

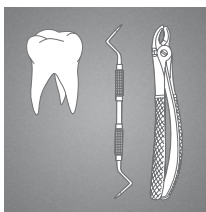

Dental, Oral*

54
-73
947-974

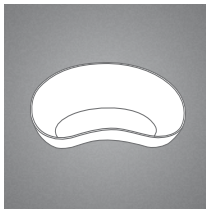

Verschiedenes
Miscellaneous
Diversos articulos
Articles divers
Articoli diversi

Weitere Kataloge von KLS Martin

Zu den folgenden Produktgruppen sind jeweils eigene Kataloge verfügbar, die Sie gerne bei uns anfordern können:

Further catalogs of KLS Martin

For the following product groups additional catalogs are available. Please ask for your personal copy:

Más catálogos de KLS Martin

Para los grupos siguientes tenemos catálogos individuales disponibles. No duden pedirnos más ejemplares:

Autres catalogues de KLS Martin

Pour les groupes de produits suivants sont disponibles des catalogues additionnels dont vous pouvez demander le nombre désiré:

Altri cataloghi di KLS Martin

Per i gruppi di prodotti seguenti sono disponibili cataloghi addizionali. La preghiamo di informarci se desidera altre copie:

76 – 79 Laserchirurgie
Laser Surgery
Cirugía láser
Chirurgie laser
Chirurgia laser

80 HF-Chirurgie
HF Surgery
Cirugía AF
Chirurgie HF
Chirurgia AF

85 Deckenversorgungseinheiten
Ceiling-mounting systems
Unidades de alimentación de techo
Unités d'alimentation montées au plafond
Sistemi pensili

86 + 89 OP-Leuchten
Operating Theatre Lights
Lámparas de quirófano
Lampes opératoires
Lampade scialitiche

* Siehe Spezialkatalog
See special catalog
Véase catálogo especial
Voyez catalogue spécial
Vedete catalogo speciale

Skalpelle
Scalpels
Bisturíes
Bistouris
Bisturi

10

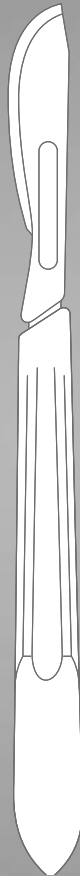

Anatomische Skalpelle

Dissecting Knives

Bisturías para disección

Bistouris à dissection

Bisturi per dissezione

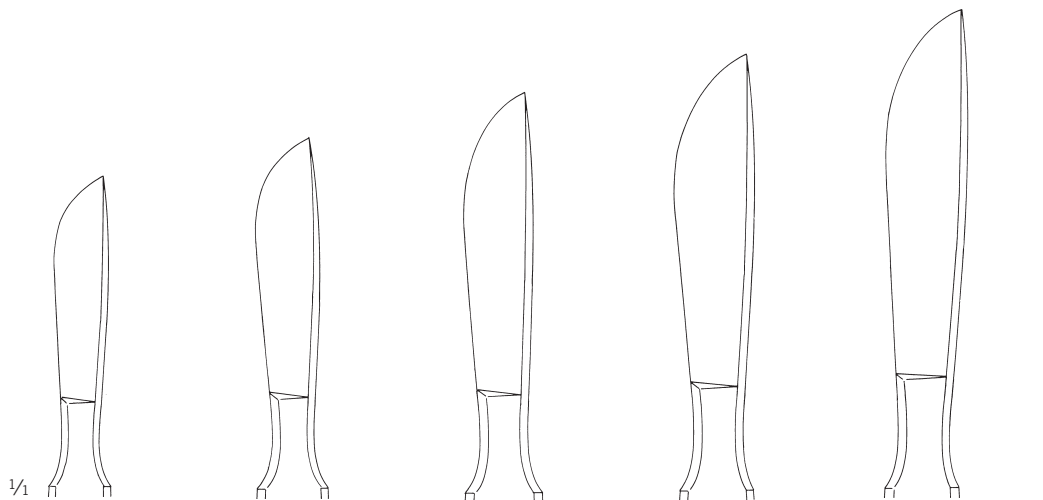

1/1

Fig. 1
10-002-01-07
15 cm / 5 7/8"



30 mm

Fig. 2
10-002-02-07
15 cm / 5 7/8"



36 mm

Fig. 3
10-002-03-07
15,5 cm / 6 1/8"



40 mm

Fig. 4
10-002-04-07
16 cm / 6 2/8"



45 mm

Fig. 5
10-002-05-07
16 cm / 6 2/8"



50 mm

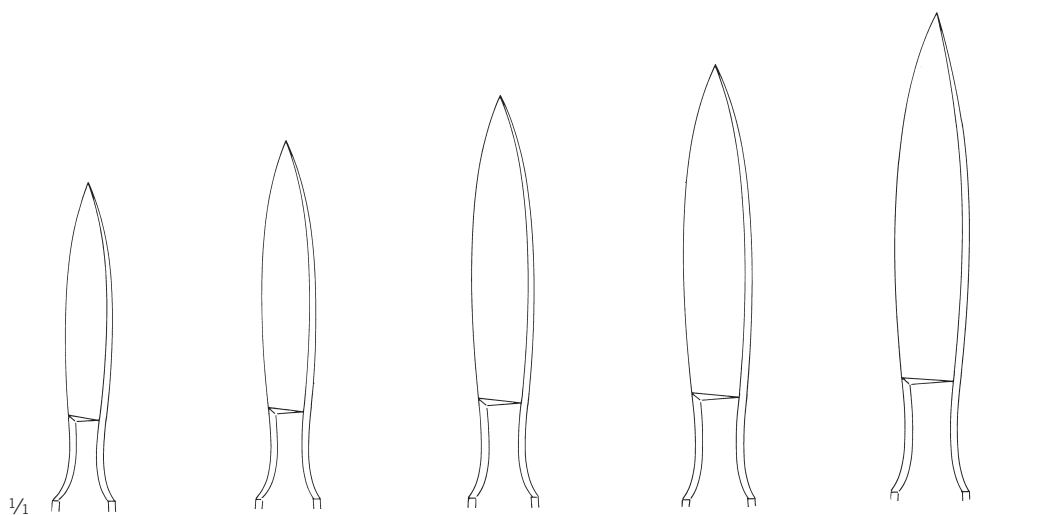

1/1

Fig. 6
10-002-06-07
15 cm / 5 7/8"



27 mm

Fig. 7
10-002-07-07
15 cm / 5 7/8"



35 mm

Fig. 8
10-002-08-07
16 cm / 6 2/8"



40 mm

Fig. 9
10-002-09-07
16 cm / 6 2/8"



47 mm

Fig. 10
10-002-10-07
17 cm / 6 6/8"



50 mm

1/2



10-002-01-07 -
10-002-10-07

mit Metallheft
with metal handle
con mango metálico
avec manche en métal
con manico di metallo

Hirnmesser

Brain Knives
Cuchillos para cerebro
Couteaux à cerveau
Coltelli per il cervello

Skalpelle

Scalpels
Bisturíes
Bistouris
Bisturi

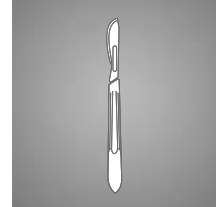

10



1/2

Virchow

10-038-16-07 -
10-038-24-07
mit Hohlheft
with hollow handle
con mango hueco
avec manche creux
con manico vuoto

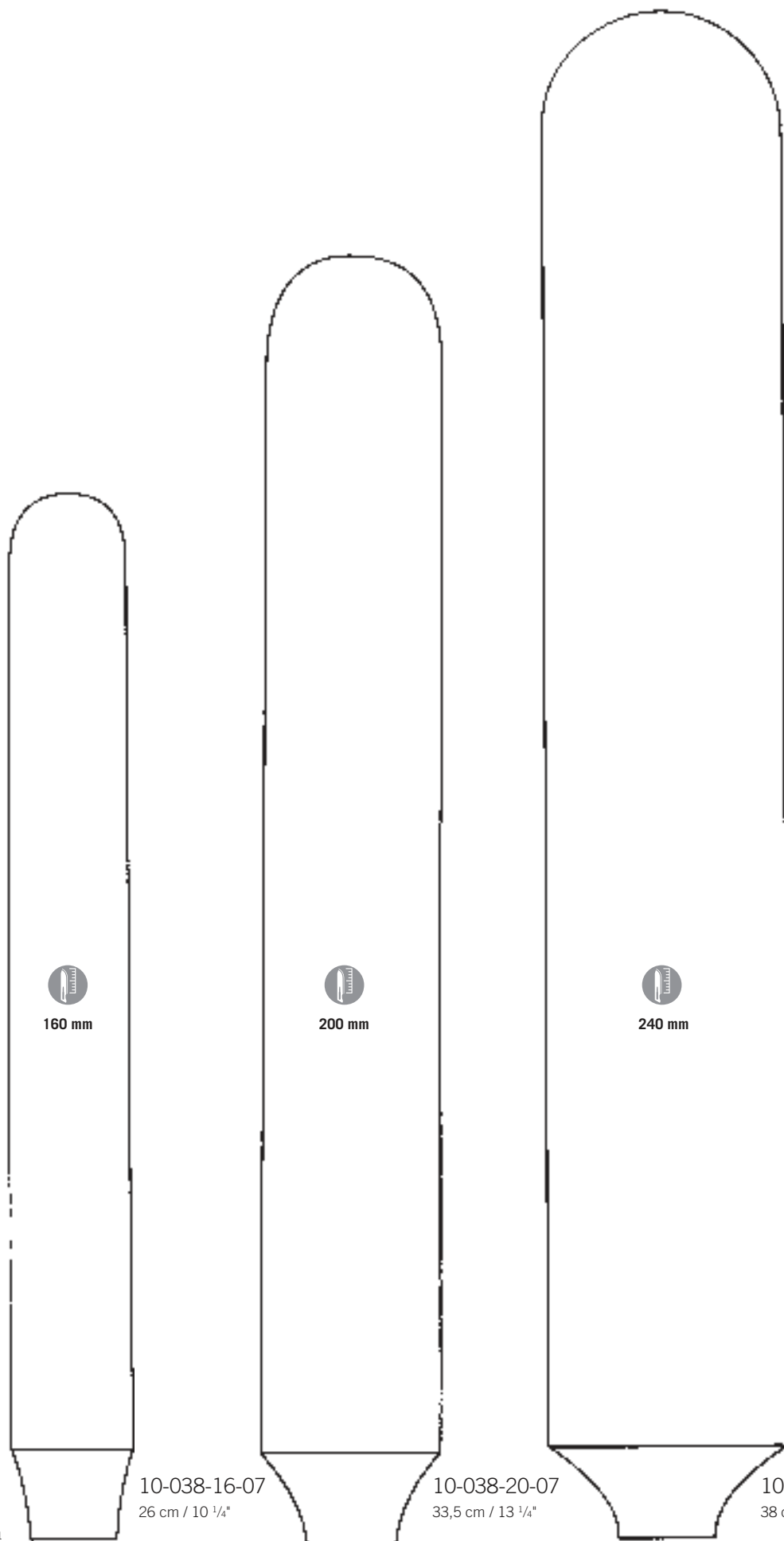

1/4

Klingenhalter / Klingenbrecher

Blade Holders / Blade Breakers

Porta-fojas / Rompe-fojas de afeitador

Pincettes pour saisir et casser les lames de rasoir

Pinze per afferrare e rompere la lametta di rasoio



Troutman-Chris
10-090-09-07
9 cm / 3 4/8"



Troutman-Chris
10-091-09-07
9 cm / 3 4/8"

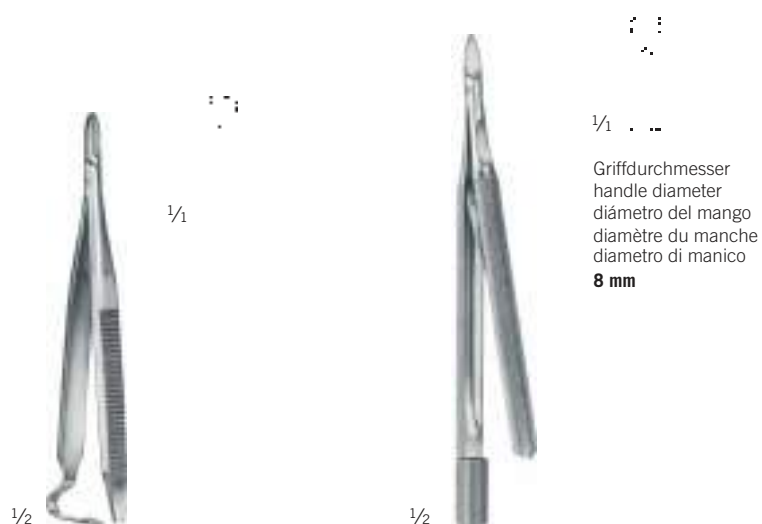

10-092-11-07
11 cm / 4 3/8"

Castroviejo
10-094-13-07
13 cm / 5 1/8"



10-096-00-07

Rasierklingen
brechbar
Packung mit 10 Stück
Razor Blades
breakable
package with 10 units
Hojas de afeitador
rompeable
paquete con 10 unidades

Lames de rasoir
cassable
boîte de 10 lames
Lamette da rasoio
rompibile
scatola di 10 lamette

Skalpellgriffe

Scalpel Handles
Mangos de bisturí
Manches pour bistouris
Manici per bisturi

Skalpelle

Scalpels
Bisturís
Bistouris
Bisturi



 Fig. 18 - 36

1/2 **Nr. 4**

10-100-04-07
13,5 cm / 5 3/8"
massiv
solid
macizo
solide
pieno



 Fig. 10 - 36

1/2 **Nr. 3 & 4**

10-100-34-07
16 cm / 6 2/8"
massiv
solid
macizo
solide
pieno



 Fig. 18 - 36

1/2 **Nr. 4L**

10-104-41-07
21 cm / 8 2/8"
massiv
solid
macizo
solide
pieno



 Fig. 18 - 36

1/2 **Nr. 4L**

10-104-45-07
20,5 cm / 8 1/8"
massiv
solid
macizo
solide
pieno

Skalpellgriffe

Scalpel Handles

Mangos de bisturí

Manches pour bistouris

Manici per bisturi



Fig. 18 - 36

1/2 Nr. 8

Collin

10-108-08-07

13,5 cm / 5 3/8"

mit Hohlheft
with hollow handle
con mango hueco
avec manche creux
con manico vuoto



Fig. 18 - 36

1/2 Nr. 9

Collin

10-109-09-07

14,5 cm / 5 9/8"

mit Hohlheft
with hollow handle
con mango hueco
avec manche creux
con manico vuoto



Fig. 18 - 36

1/2 Nr. 4

10-112-04-07

13,5 cm / 5 3/8"

mit Kunststoffheft
with plastic handle
con mango plástico
avec manche en matière plastique
con mango plástico



Fig. 10 - 17

1/2

10-116-03-07

16 cm / 6 2/8"

1,0/1,5 mm



Fig. 10 - 17

1/2

10-117-03-07

16 cm / 6 2/8"

1,5/2,0 mm



Fig. 10 - 17

1/2

10-118-03-07

15,5 cm / 6 1/8"

Schwenkkopf
swivel head
con cabeza orientable
à tête pivotante
con testa inclinabile



Fig. 10 - 17

1/2

10-120-04-07

16,5 cm / 6 2/8"

Skalpellgriffe

Scalpel Handles

Mangos de bisturí

Manches pour bistouris

Manici per bisturi

Skalpelle

Scalpels

Bisturíes

Bistouris

Bisturi

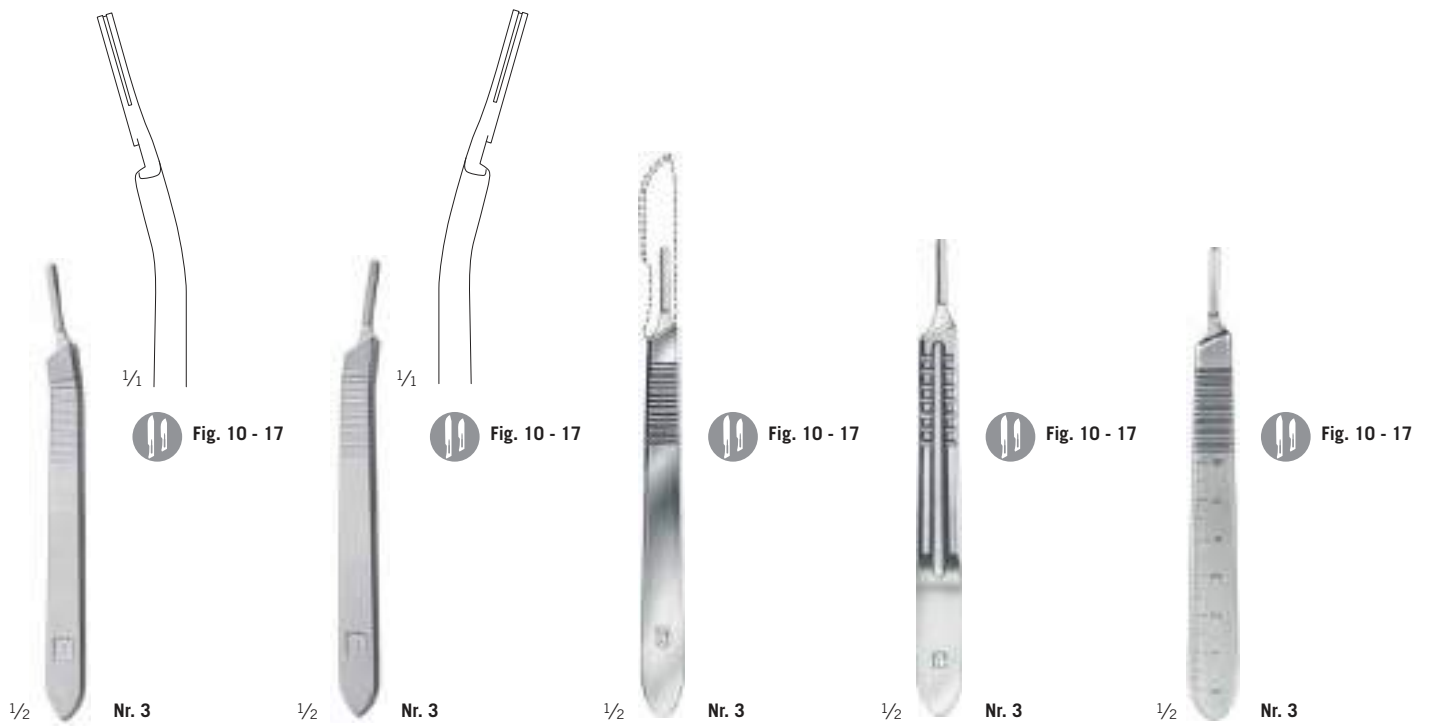

10-125-01-07

12 cm / 4 6/8"

links
left
izquierdo
gauche
sinistra

10-125-02-07

12 cm / 4 6/8"

rechts
right
derecho
droit
destra

10-130-03-07

12 cm / 4 6/8"

massiv
solid
macizo
solide
pieno

10-130-04-07

12 cm / 4 6/8"

massiv
solid
macizo
solide
pieno

10-130-05-07

12 cm / 4 6/8"

massiv, mit Zentimeter-
Graduierung
solid, cm-graduation
macizo, graduado en cm
solide, gradué en cm
pieno, graduato in cm

Skalpellgriffe

Scalpel Handles

Mangos de bisturí

Manches pour bistouris

Manici per bisturi



Fig. 10 - 17

Nr. 3L

1/2

10-133-31-07

21,5 cm / 8 4/8"

massiv, lang
solid, long
macizo, largo
solide, long
pieno, lungo

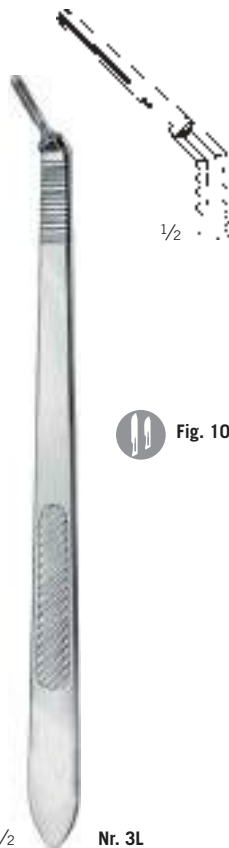

Fig. 10 - 17

Nr. 3L

1/2

10-133-35-07

20,5 cm / 8 1/8"

massiv, abgewinkelt, lang
solid, angled, long
macizo, angulado, largo
solide, coudé, long
pieno, angolare, lungo



Fig. 10 - 17

Nr. 3XL

1/2

10-135-01-07

26 cm / 10 2/8"

massiv, lang
solid, long
macizo, largo
solide, long
pieno, lungo

Skalpellgriffe

Scalpel Handles
Mangos de bisturí
Manches pour bistouris
Manici per bisturi

Skalpelle

Scalpels
Bisturíes
Bistouris
Bisturi

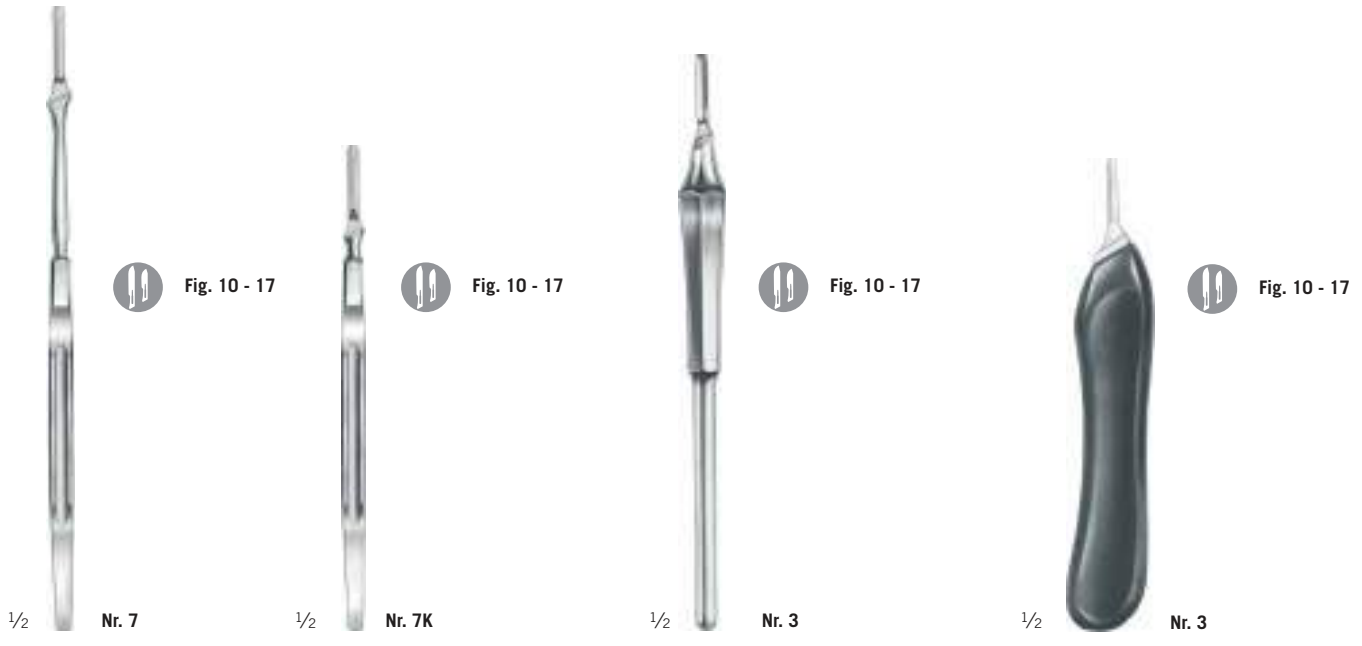
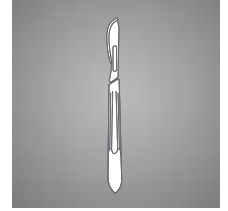

10-137-07-07
16 cm / 6 2/8"
massiv
solid
macizo
solide
pieno

10-137-71-07
12,5 cm / 4 7/8"
massiv
solid
macizo
solide
pieno

10-140-03-07
15,5 cm / 6 1/8"
mit rundem Hohlheft
with round hollow handle
con mango hueco redondo
avec manche creux rond
con manico vuoto rotondo

10-142-03-07
12,5 cm / 4 7/8"
mit Kunststoffheft
with plastic handle
con mango plástico
avec manche en matière plastique
con manico di materia plastica

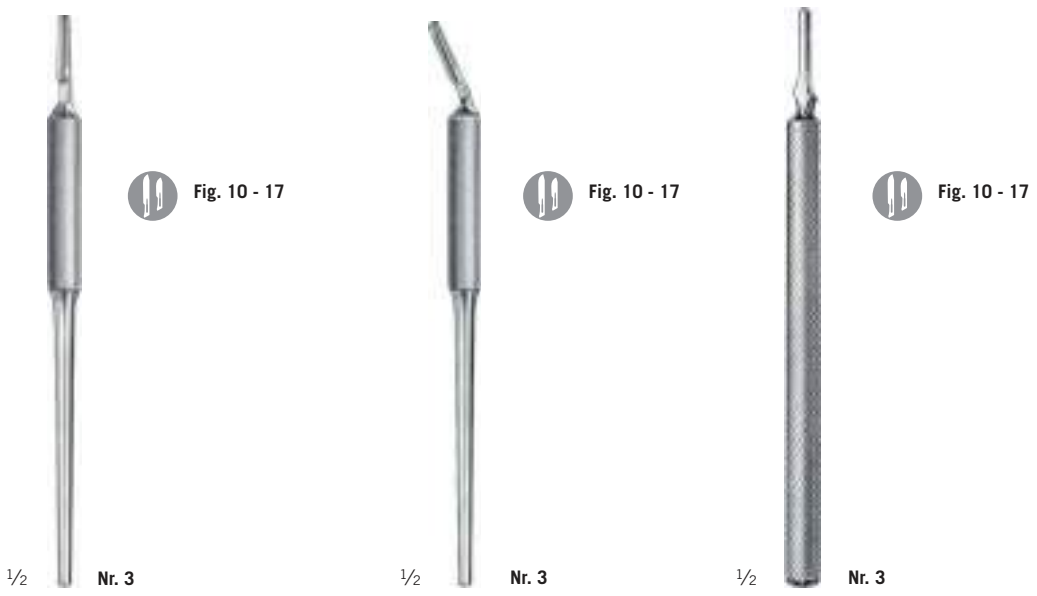

10-146-03-07
14 cm / 5 4/8"
massiv
solid
macizo
solide
pieno

10-147-03-07
14 cm / 5 4/8"
massiv
solid
macizo
solide
pieno

Kaye
10-148-03-07
15 cm / 5 7/8"
massiv
solid
macizo
solide
pieno

Skalpellklingen

Scalpel Blades
Hojas de bisturí
Lames de bistouris
Lame per bisturi



1/1

STERILE R

Sägeblatt für Griffe No. 3
Packung mit 1 Stück

Saw Blade for handles no. 3
package with 1 unit

Hoja de sierra para mangos no. 3
paquete con 1 unidad

Lames de scies pour manche no. 3
boîte de 1 lame

Lame per seghe per i manici no. 3
scatola di 1 lama

steril • sterile • estéril • stérile • sterile

10-155-09-04



10-199-00-01

Skalpellklingen-Entferner
Scalpel Blade Remover
Quita-hojas
Enlève-lame
Distributore lame

STERILE R

einzel verpackt, VE = 100 Stück
single packed, SU = 100/pack
envase individual, UV = 100 piezas
enveloppe individuelle, UC = 100 untiés
bustina individuale, UV = 100 pezzi



1/1

unsteril • non-sterile • no estéril • non-stérile • non sterile

10-150-10-04 10-150-11-04 10-150-12-04 10-150-13-04 10-150-15-04

Fig. 10 Fig. 11 Fig. 12 Fig. 13 Fig. 15

steril • sterile • estéril • stérile • sterile

10-155-10-04 10-155-11-04 10-155-12-04 10-155-13-04 10-155-15-04

Fig. 10 Fig. 11 Fig. 12 Fig. 13 Fig. 15



1/1

unsteril • non-sterile • no estéril • non-stérile • non sterile

10-150-16-04 10-150-17-04 10-151-12-04 10-151-15-04

Fig. 16 Fig. 17 Fig. 12 D Fig. 15 C

steril • sterile • estéril • stérile • sterile

10-155-16-04 10-155-17-04 10-156-12-04 10-156-15-04

Fig. 16 Fig. 17 Fig. 12 D Fig. 15 C

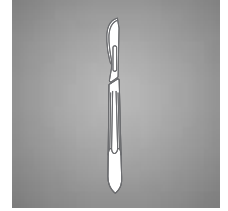

STERILE R

einzel verpackt, VE = 100 Stück
single packed, SU = 100/pack
envase individual, UV = 100 piezas
enveloppe individuelle, UC = 100 untiés
bustina individuale, UV = 100 pezzi

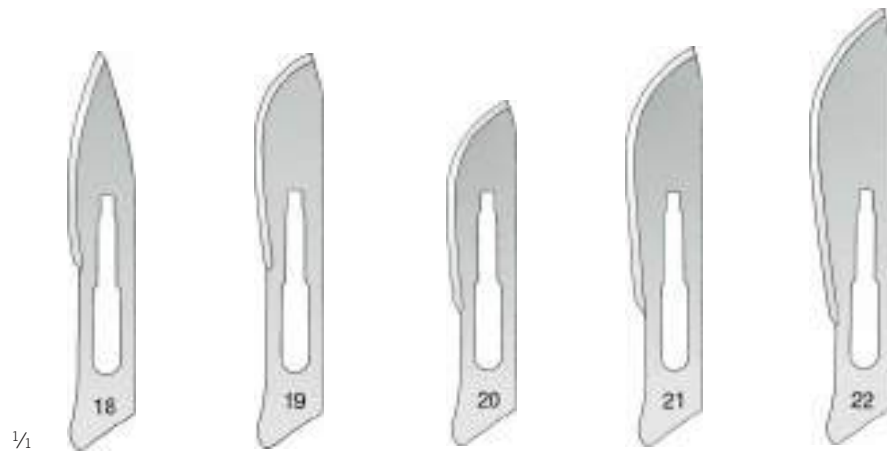

1/1

unsteril • non-sterile • no estéril • non-stérile • non sterile				
10-150-18-04	10-150-19-04	10-150-20-04	10-150-21-04	10-150-22-04
Fig. 18	Fig. 19	Fig. 20	Fig. 21	Fig. 22

steril • sterile • estéril • stérile • sterile				
10-155-18-04	10-155-19-04	10-155-20-04	10-155-21-04	10-155-22-04
Fig. 18	Fig. 19	Fig. 20	Fig. 21	Fig. 22



1/1

unsteril • non-sterile • no estéril • non-stérile • non sterile			
10-150-23-04	10-150-24-04	10-150-34-04	10-150-36-04
Fig. 23	Fig. 24	Fig. 34	Fig. 36

steril • sterile • estéril • stérile • sterile			
10-155-23-04	10-155-24-04	10-155-34-04	10-155-36-04
Fig. 23	Fig. 24	Fig. 34	Fig. 36

Skalpellgriffe

Scalpel Handles

Mangos de bisturí

Manches pour bistouris

Manici per bisturi

Ti



1/1

10-159-00-09

13,5 cm / 5 3/8"

für Mikro-Skalpellklingen
for micro scalpel blades
para micro hojas
pour micro-lames de bisturis
per micro lame



1/1

10-160-01-07

13,5 cm / 5 3/8"

für Mikro-Skalpellklingen
for micro scalpel blades
para micro hojas
pour micro-lames de bisturis
per micro lame

Einmalskalpelle

Disposable Scalpels
Bisturíes desechables
Bistouris à usage unique
Bisturi per uso unico

Skalpelle

Scalpels
Bisturíes
Bistouris
Bisturi

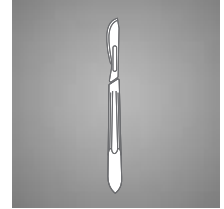

10

STERILE | R

steril
einzeln verpackt
Packung mit 10 Stück

sterile
single packed
package with 10 units

estéril
envase individual
paquete con 10 unidades

stérile
enveloppe individuelle
boîte de 10 bisturis

sterile
bustina individuale
scatola di 10 bisturi

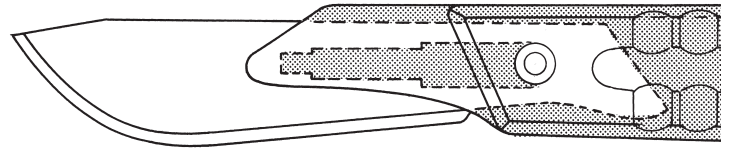

1/1

steril • sterile • estéril • stérile • sterile

10-285-18-04

10-285-19-04

10-285-20-04

10-285-21-04

10-285-22-04

10-285-23-04

10-285-24-04

Fig. 18

Fig. 19

Fig. 20

Fig. 21

Fig. 22

Fig. 23

Fig. 24

Einmalskalpelle

Disposable Scalpels
Bisturíes desechables
Bistouris à usage unique
Bisturi per uso unico

STERILE | R

steril
einzeln verpackt
Packung mit 10 Stück

stérile
enveloppe individuelle
boîte de 10 bisturis

sterile
single packed
package with 10 units

sterile
bustina individuale
scatola di 10 bisturi

estéril
envase individual
paquete con 10 unidades



1/1

steril • sterile • estéril • stérile • sterile

10-295-10-04

10-295-11-04

10-295-12-04

10-295-13-04

10-295-15-04

10-296-12-04

10-296-15-04

Fig. 10

Fig. 11

Fig. 12

Fig. 13

Fig. 15

Fig. 12 D

Fig. 15 C

Amputationsmesser, Resektionsmesser

Amputation Knives, Resection Knives

Cuchillos para amputación, Cuchillos para resección

Couteaux à amputation, Couteaux à résection

Coltelli per amputazione, Coltelli per resezione

Skalpelle

Scalpels

Bisturís

Bistouris

Bisturi

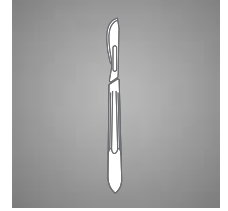

10

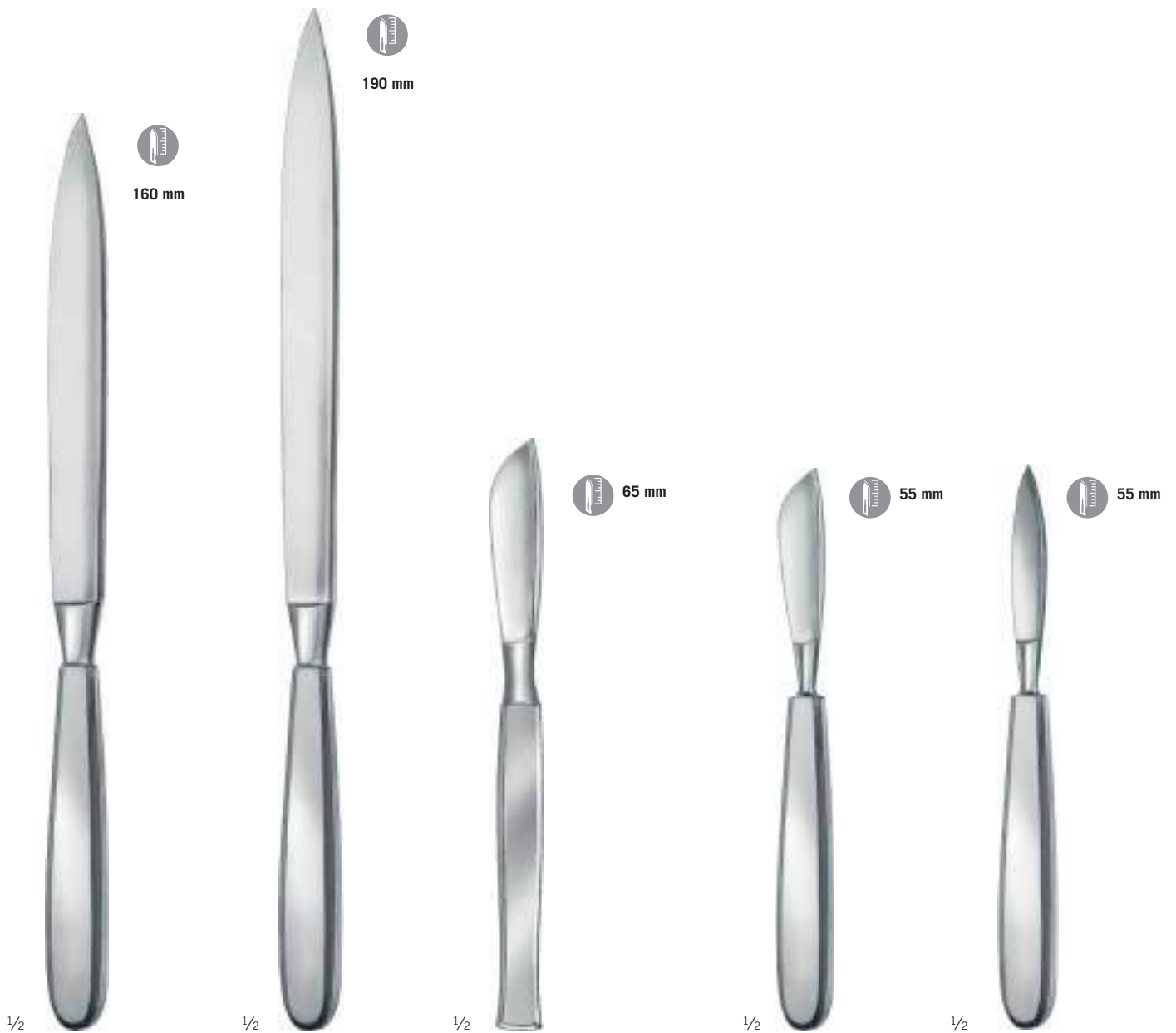

Liston
10-500-16-07

29 cm / 11 ³/₈"
mit Hohlheft
with hollow handle
con mango hueco
avec manche creux
con manico vuoto

Liston
10-500-19-07

32 cm / 12 ⁵/₈"
mit Hohlheft
with hollow handle
con mango hueco
avec manche creux
con manico vuoto

10-560-06-07

19 cm / 7 ⁴/₈"
massives Heft mit Schaber-Ende
solid handle, with dissecting end
mango macizo, con periostótopo
manche solide à rugine
con manico pieno con raschino

Langenbeck
10-570-05-07

18 cm / 7 ¹/₈"
mit Hohlheft
with hollow handle
con mango hueco
avec manche creux
con manico vuoto

Langenbeck
10-572-05-07

18 cm / 7 ¹/₈"
mit Hohlheft
with hollow handle
con mango hueco
avec manche creux
con manico vuoto

Rasiermesser

Razor Knives

Navajas

Rasoirs

Rasoi

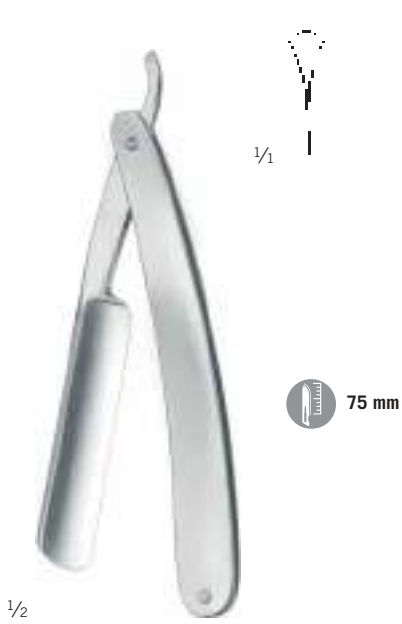

10-800-00-07

Klinge beidseitig hohl
hollow blade on both sides
ambos lados cóncavos
lame deux faces concaves
lama concava/concava

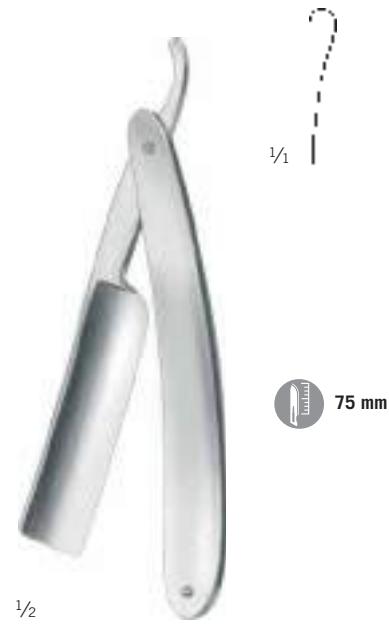

10-811-00-07

Klinge flach/hohl
blade flat/hollow
hoja cóncava/convexa
lame à faces plane/concave
lama piana/concava



Record-Arkansas
10-875-00-04

Abziehstein, im Holzkasten
Sharpening Stone, in wooden case
Piedra afiladora, en caja madera
Pierre à repasser, en boîte bois
Pietra per affilare, in astuccio di legno



Record-Arkansas
10-877-00-04

Abziehstein
Sharpening Stone
Piedra afiladora
Pierre à repasser
Pietra per affilare

Rasiermesser

Razor Knives

Navajas

Rasoirs

Rasoi

Skalpelle

Scalpels

Bisturís

Bistouris

Bisturi



1/2

Humby
10-878-00-07

32 cm / 12 5/8"

komplett mit Klinge
complete with blade
completo con hoja
complet avec lame
completo con lama

Humby
10-878-01-07

Ersatzklinge
Spare Blade
Hoja de repuesto
Lame de rechange, seule
Lama di ricambio sola

➔ 10-878-00-07



1/2

Schink
10-880-00-07

30 cm / 11 5/8"

einstellbar von 0,1 bis 2,0 mm
adjustable from 0.1 to 2.0 mm
ajustable de 0,1 hasta 2,0 mm
réglable en épaisseur de 0,1 à 2,0 mm
regolabile da 1,0 a 2,0 mm

komplett mit 2 Spannplatten und einer Klinge
complete with 2 skin fixing plates and one blade
completo con 2 placas para extender la piel y una hoja
complet avec deux plaques pour tendre la peau et une lame
completo con 2 placche per stendere la pelle ed una lama

Schink
10-880-01-07

Ersatzklinge
Spare Blade
Hoja de repuesto
Lame de rechange, seule
Lama di ricambio sola

➔ 10-880-00-07



1/2

Schink
10-880-02-07

Spannplatte
Skin Fixing Plate
Placa para extender la piel
Plaque pour tendre la peau
Placca per stendere la pelle

➔ 10-880-00-07



1/2

Silver
10-882-19-07

19,5 cm / 7 5/8"

Handdermatom
Dermatome
Dermatomo
Dermatome
Dermatomo a mano

für handelsübliche Rasierklingen
for usual razor blades
para hojas de afeitar usuales
pour lames de rasoir modèle standard
per lamette da barba normali

Scheren
Scissors
Tijeras
Ciseaux
Forbici

11

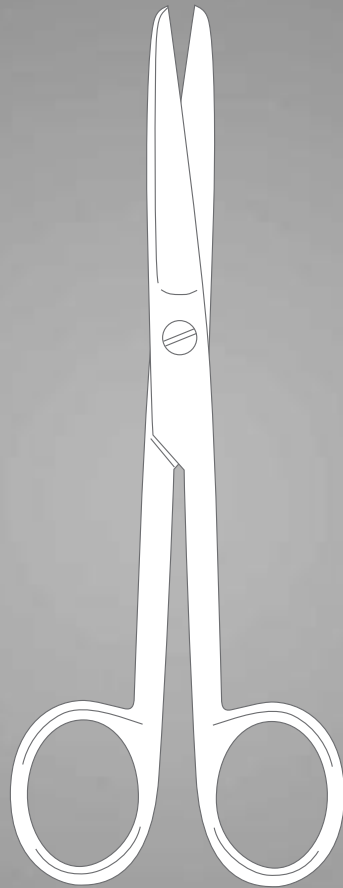

Chirurgische Scheren

Operating Scissors

Tijeras quirúrgicas

Ciseaux chirurgicaux

Forbici per chirurgia



1/2



1/2

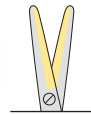

TC GOLD

	Standard	TCGOLD
12 cm / 4 5/8"	11-100-11-07	
13 cm / 5 1/8"	11-100-13-07	
14,5 cm / 5 6/8"	11-100-14-07	11-902-14-07
15,5 cm / 6 1/8"	11-100-15-07	
16,5 cm / 6 4/8"	11-100-16-07	
17,5 cm / 6 7/8"	11-100-17-07	
18,5 cm / 7 2/8"	11-100-18-07	
20,5 cm / 8 1/8"	11-100-20-07	

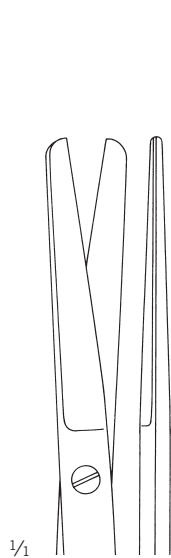

1/1

12 cm / 4 5/8"

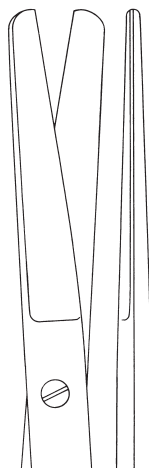

13 cm / 5 1/8"

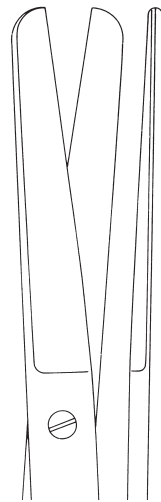

14,5 cm / 5 6/8"



15,5 cm / 6 1/8"

Chirurgische Scheren

Operating Scissors

Tijeras quirúrgicas

Ciseaux chirurgicaux

Forbici per chirurgia

Scheren

Scissors

Tijeras

Ciseaux

Forbici

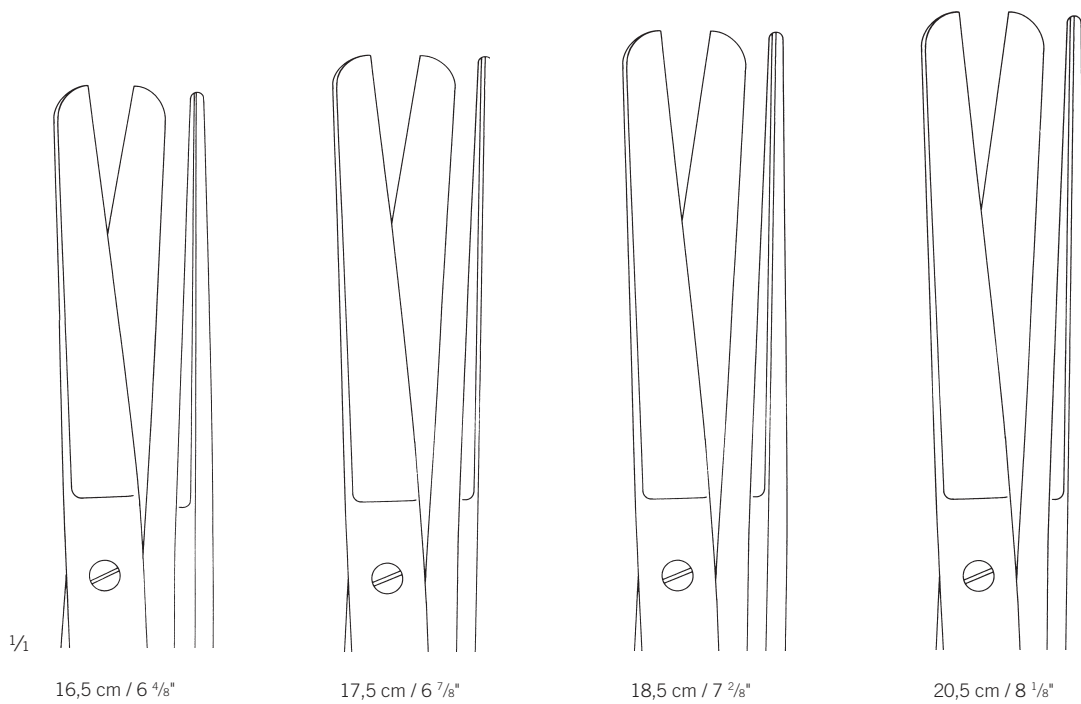

1/1

16,5 cm / 6 4/8"

17,5 cm / 6 7/8"

18,5 cm / 7 2/8"

20,5 cm / 8 1/8"

Chirurgische Scheren

Operating Scissors

Tijeras quirúrgicas

Ciseaux chirurgicaux

Forbici per chirurgia



1/2



1/2

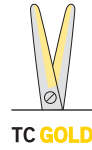

TC GOLD



1/2



SuperCut

	Standard	TCGOLD	SuperCut
12 cm / 4 5/8"	11-102-11-07		
13 cm / 5 1/8"	11-102-13-07		
14,5 cm / 5 7/8"	11-102-14-07	11-904-14-07	11-650-14-07
15,5 cm / 6 1/8"	11-102-15-07		
16,5 cm / 6 5/8"	11-102-16-07		
17,5 cm / 6 7/8"	11-102-17-07		
18,5 cm / 7 3/8"	11-102-18-07		
20,5 cm / 8 1/8"	11-102-20-07		

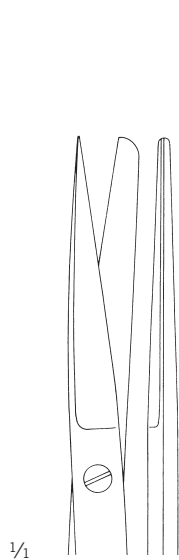

1/1

12 cm / 4 5/8"



13 cm / 5 1/8"

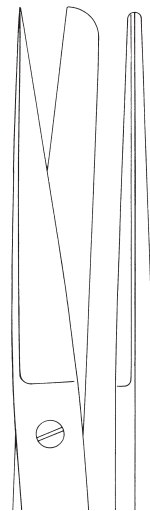

14,5 cm / 5 7/8"

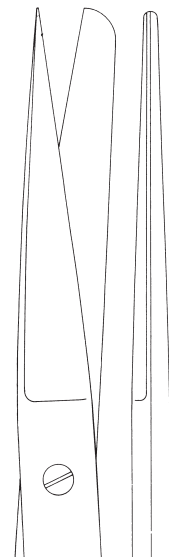

15,5 cm / 6 1/8"

Chirurgische Scheren

Operating Scissors
Tijeras quirúrgicas
Ciseaux chirurgicaux
Forbici per chirurgia

Scheren

Scissors
Tijeras
Ciseaux
Forbici

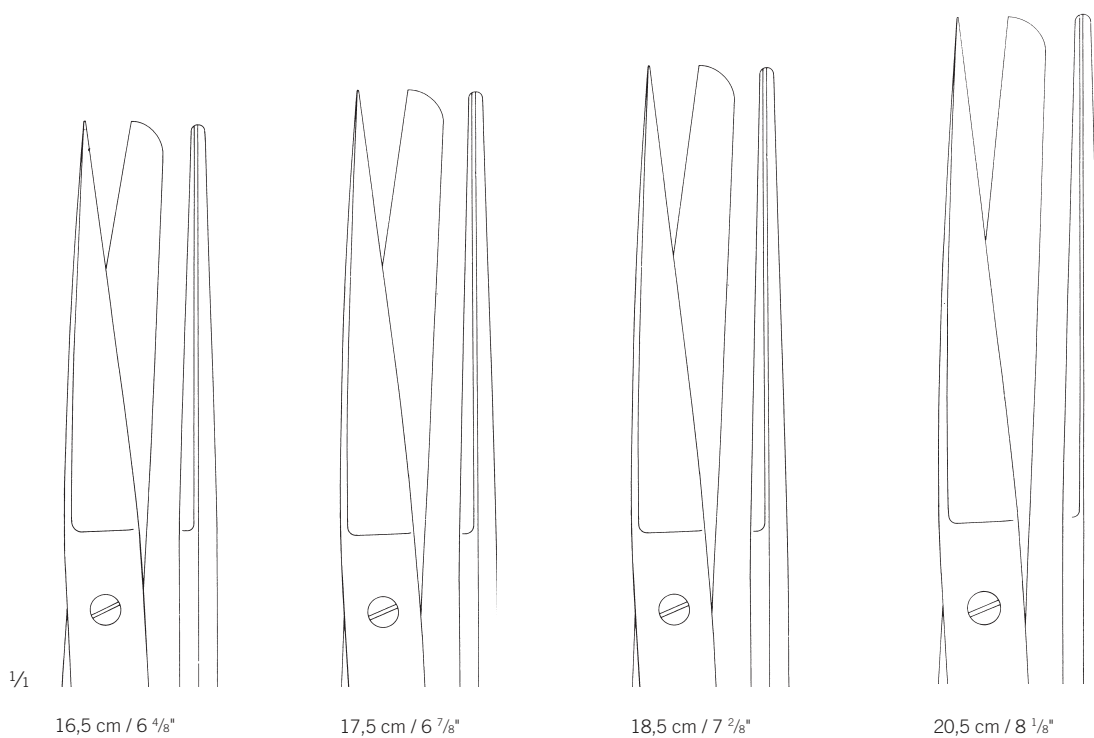

Chirurgische Scheren

Operating Scissors

Tijeras quirúrgicas

Ciseaux chirurgicaux

Forbici per chirurgia



1/2



1/2

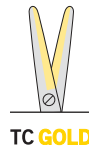

TC GOLD

	Standard	TCGOLD
12 cm / 4 5/8"	11-104-11-07	
13 cm / 5 1/8"	11-104-13-07	
14,5 cm / 5 7/8"	11-104-14-07	11-906-14-07
15,5 cm / 6 1/8"	11-104-15-07	
16,5 cm / 6 4/8"	11-104-16-07	



1/1

12 cm / 4 5/8"



13 cm / 5 1/8"

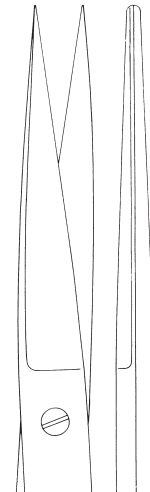

14,5 cm / 5 7/8"

Chirurgische Scheren

Operating Scissors
Tijeras quirúrgicas
Ciseaux chirurgicaux
Forbici per chirurgia

Scheren

Scissors
Tijeras
Ciseaux
Forbici

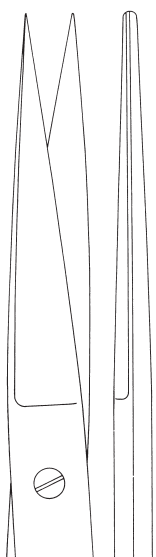

15,5 cm / 6 1/8"

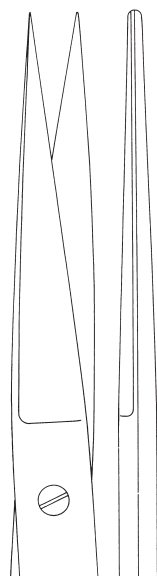

16,5 cm / 6 4/8"

Chirurgische Scheren

Operating Scissors

Tijeras quirúrgicas

Ciseaux chirurgicaux

Forbici per chirurgia



1/2



1/2

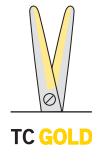

TC GOLD

	Standard	TCGOLD
12 cm / 4 5/8"	11-105-11-07	
13 cm / 5 1/8"	11-105-13-07	
14,5 cm / 5 7/8"	11-105-14-07	11-903-14-07
15,5 cm / 6 1/8"	11-105-15-07	
16,5 cm / 6 5/8"	11-105-16-07	
17,5 cm / 6 7/8"	11-105-17-07	
18,5 cm / 7 3/8"	11-105-18-07	
20,5 cm / 8 1/8"	11-105-20-07	



1/1

12 cm / 4 5/8"



13 cm / 5 1/8"

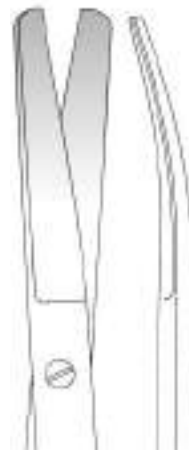

14,5 cm / 5 7/8"

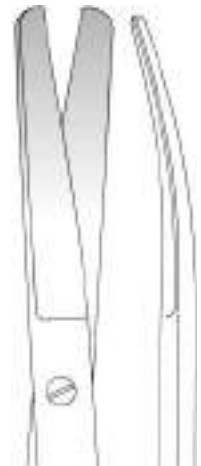

15,5 cm / 6 1/8"

Chirurgische Scheren

Operating Scissors
Tijeras quirúrgicas
Ciseaux chirurgicaux
Forbici per chirurgia

Scheren

Scissors
Tijeras
Ciseaux
Forbici



1/1



16,5 cm / 6 4/8"

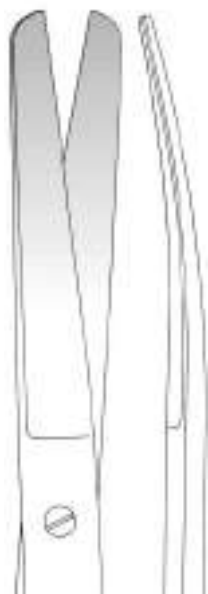

17,5 cm / 6 7/8"

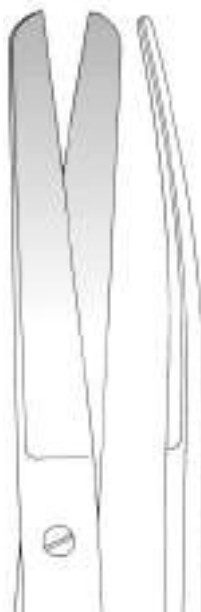

18,5 cm / 7 2/8"



20,5 cm / 8 1/8"

Chirurgische Scheren

Operating Scissors

Tijeras quirúrgicas

Ciseaux chirurgicaux

Forbici per chirurgia



1/2



1/2

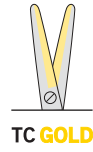

1/2



	Standard	TCGOLD	SuperCut
12 cm / 4 5/8"	11-107-11-07		
13 cm / 5 1/8"	11-107-13-07		
14,5 cm / 5 7/8"	11-107-14-07	11-905-14-07	11-651-14-07
15,5 cm / 6 1/8"	11-107-15-07		
16,5 cm / 6 4/8"	11-107-16-07		
17,5 cm / 6 7/8"	11-107-17-07		
18,5 cm / 7 2/8"	11-107-18-07		
20,5 cm / 8 1/8"	11-107-20-07		

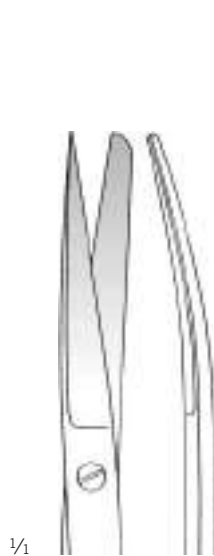

1/4

12 cm / 4 5/8"



13 cm / 5 1/8"



14,5 cm / 5 7/8"

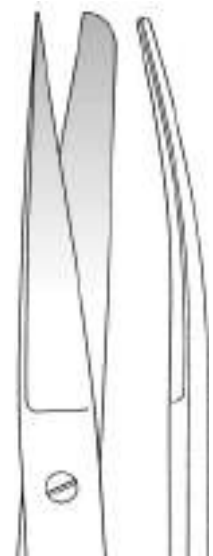

15,5 cm / 6 1/8"

Chirurgische Scheren

Operating Scissors
Tijeras quirúrgicas
Ciseaux chirurgicaux
Forbici per chirurgia

Scheren

Scissors
Tijeras
Ciseaux
Forbici



1/1

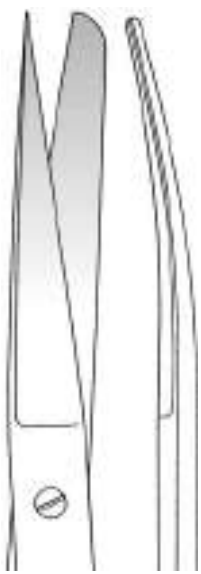

16,5 cm / 6 4/8"

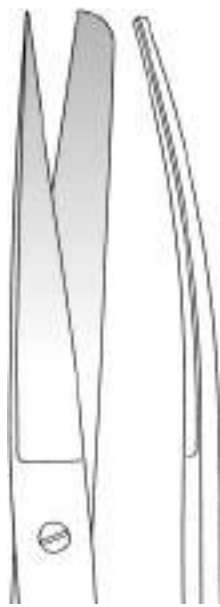

17,5 cm / 6 7/8"

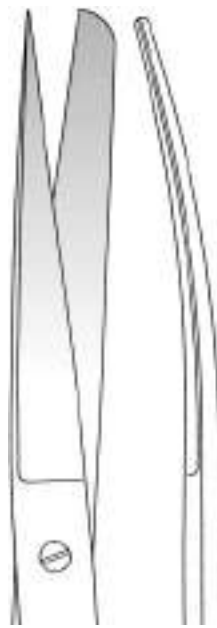

18,5 cm / 7 2/8"

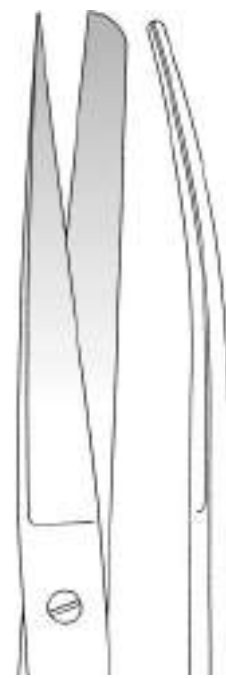

20,5 cm / 8 1/8"

Chirurgische Scheren

Operating Scissors

Tijeras quirúrgicas

Ciseaux chirurgicaux

Forbici per chirurgia



1/2



1/2

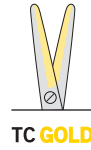

TC GOLD

	Standard	TCGOLD
12 cm / 4 5/8"	11-109-11-07	
13 cm / 5 1/8"	11-109-13-07	
14,5 cm / 5 7/8"	11-109-14-07	11-907-14-07
15,5 cm / 6 1/8"	11-109-15-07	
16,5 cm / 6 4/8"	11-109-16-07	



1/1

12 cm / 4 5/8"



13 cm / 5 1/8"



14,5 cm / 5 7/8"



15,5 cm / 6 1/8"



16,5 cm / 6 4/8"

Chirurgische Scheren

Operating Scissors

Tijeras quirúrgicas

Ciseaux chirurgicaux

Forbici per chirurgia

Scheren

Scissors

Tijeras

Ciseaux

Forbici

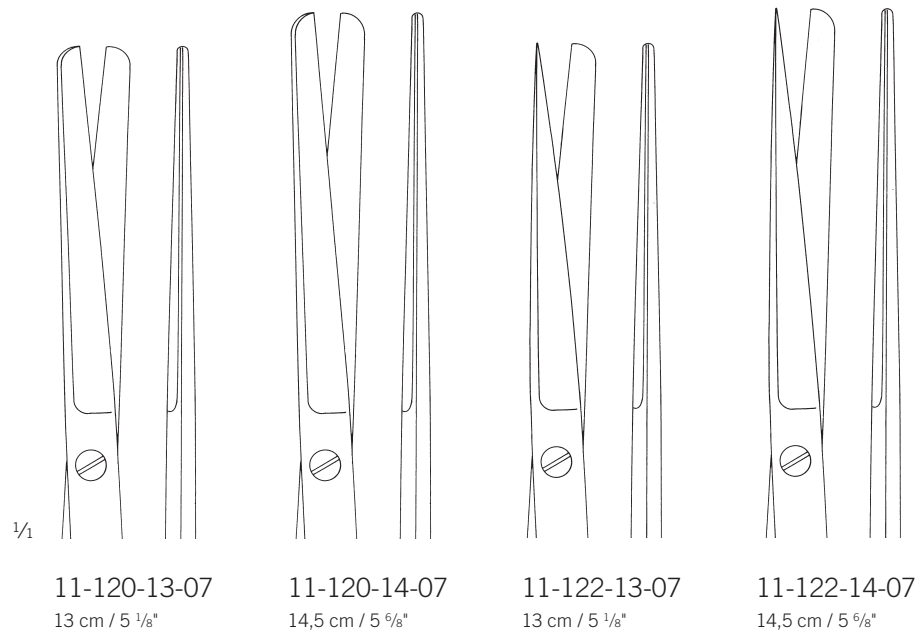

1/1

11-120-13-07
13 cm / 5 1/8"

11-120-14-07
14,5 cm / 5 6/8"

11-122-13-07
13 cm / 5 1/8"

11-122-14-07
14,5 cm / 5 6/8"

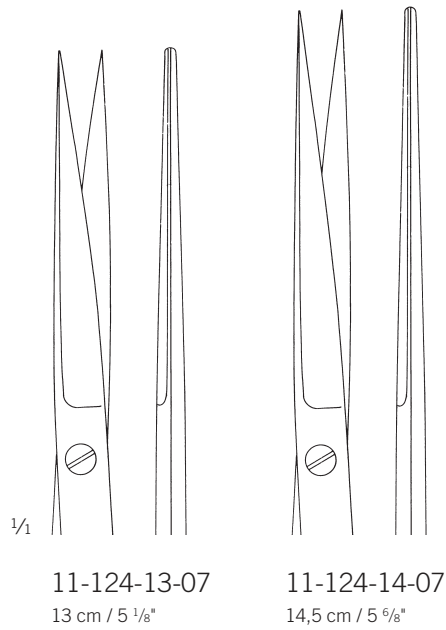

1/1

11-124-13-07
13 cm / 5 1/8"

11-124-14-07
14,5 cm / 5 6/8"



1/2

11-120-14-07 -
11-124-14-07

Chirurgische Scheren

Operating Scissors

Tijeras quirúrgicas

Ciseaux chirurgicaux

Forbici per chirurgia



11-125-13-07
13 cm / 5 1/8"

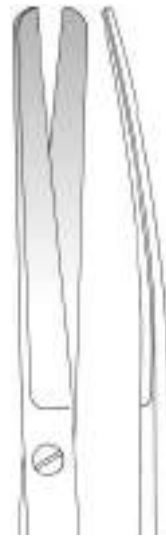

11-125-14-07
14,5 cm / 5 9/16"

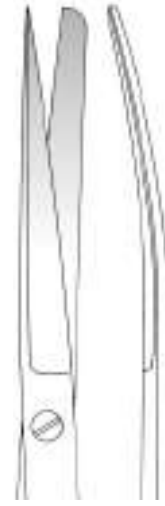

11-127-13-07
13 cm / 5 1/8"



11-127-14-07
14,5 cm / 5 9/16"



11-129-13-07
13 cm / 5 1/8"



11-129-14-07
14,5 cm / 5 9/16"



11-125-14-07 -
11-129-14-07

Chirurgische Scheren

Operating Scissors
Tijeras quirúrgicas
Ciseaux chirurgicaux
Forbici per chirurgia

Scheren

Scissors
Tijeras
Ciseaux
Forbici

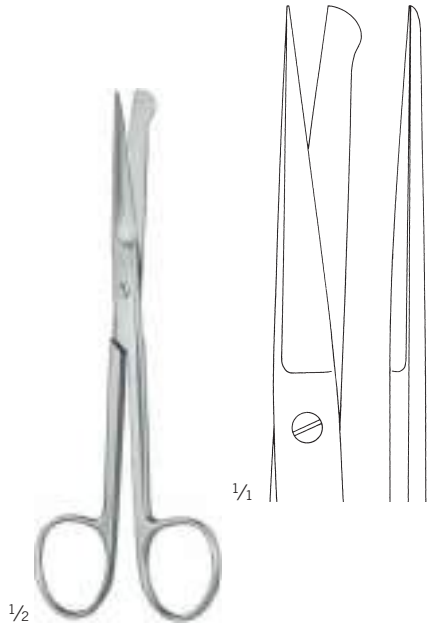

11-136-14-07

14,5 cm / 5 7/8"

Inzisionsschere
Incision Scissors
Tijera para incisiones
Ciseaux à incision
Forbici per incisione

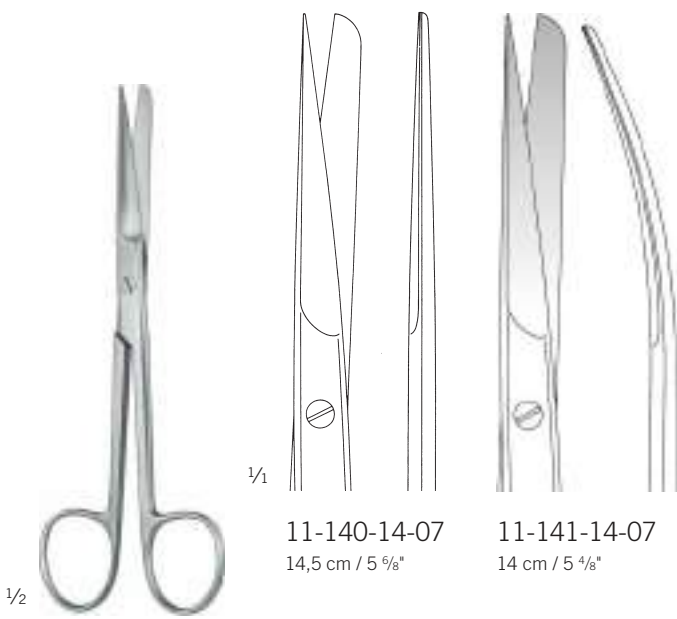

11-140-14-07
14,5 cm / 5 7/8"

11-141-14-07
14 cm / 5 4/8"



Deaver
11-142-15-07
14,5 cm / 5 7/8"

Deaver
11-140-14-07 -
11-141-14-07

Präparierscheren

Dissecting Scissors
Tijeras de disección
Ciseaux à dissection
Forbici per dissezione



Mayo	Standard	TCGOLD	SuperCut
14,5 cm / 5 7/8"	11-170-14-07	11-910-14-07	11-652-14-07
15 cm / 5 7/8"	11-170-15-07		
17 cm / 6 5/8"	11-170-17-07	11-910-17-07	11-652-17-07
23,5 cm / 9 2/8"	11-170-23-07	11-910-23-07	11-652-23-07

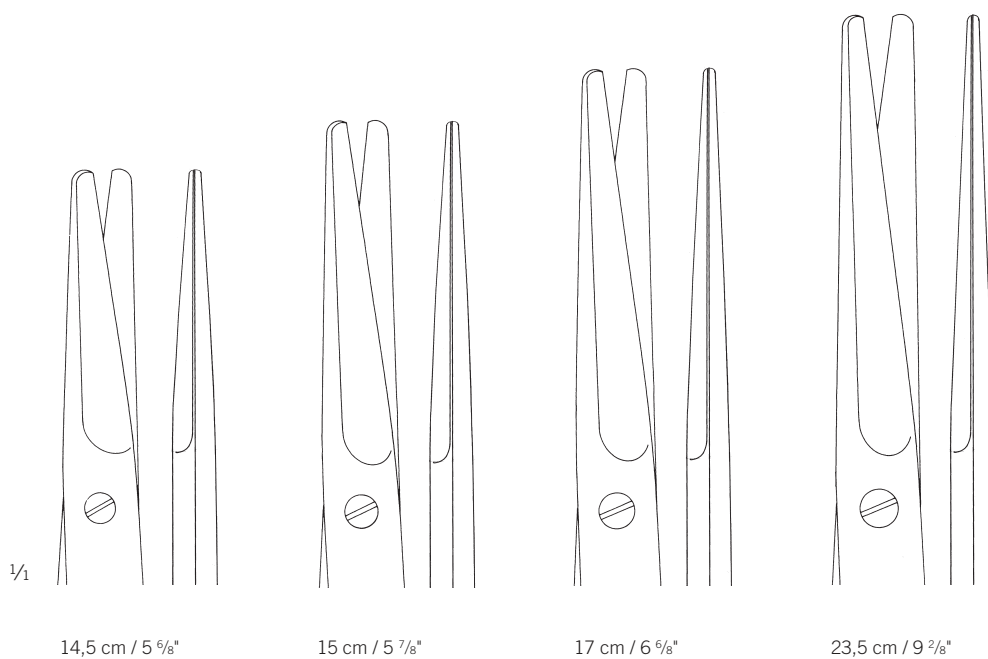

14,5 cm / 5 7/8"

15 cm / 5 7/8"

17 cm / 6 5/8"

23,5 cm / 9 2/8"

Präparierscheren

Dissecting Scissors
Tijeras de disección
Ciseaux à dissection
Forbici per dissezione

Scheren

Scissors
Tijeras
Ciseaux
Forbici



Mayo	Standard	TCGOLD	SuperCut
14,5 cm / 5 7/8"	11-171-14-07	11-911-14-07	11-653-14-07
15 cm / 5 7/8"	11-171-15-07		
17 cm / 6 5/8"	11-171-17-07	11-911-17-07	11-653-17-07
23,5 cm / 9 2/8"	11-171-23-07	11-911-23-07	11-653-23-07

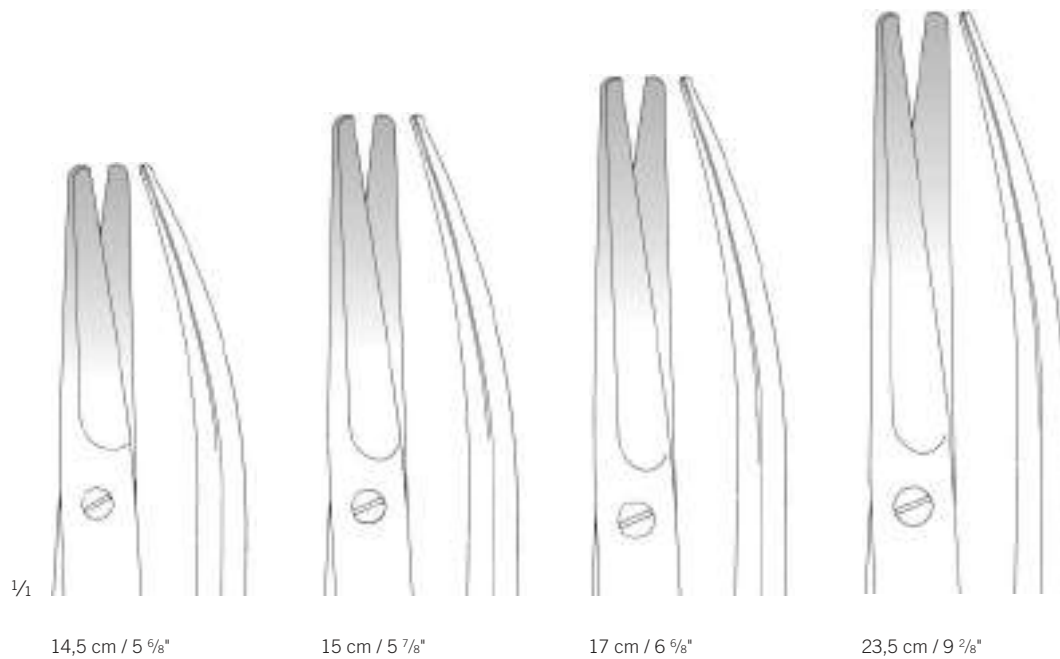

14,5 cm / 5 7/8"

15 cm / 5 7/8"

17 cm / 6 5/8"

23,5 cm / 9 2/8"

Präparierscheren

Dissecting Scissors
Tijeras de disección
Ciseaux à dissection
Forbici per dissezione



Mayo-Stille	Standard	TCGOLD	SuperCut
15 cm / 5 7/8"	11-180-15-07	11-930-15-07	11-654-15-07
17 cm / 6 6/8"	11-180-17-07	11-930-17-07	11-654-17-07

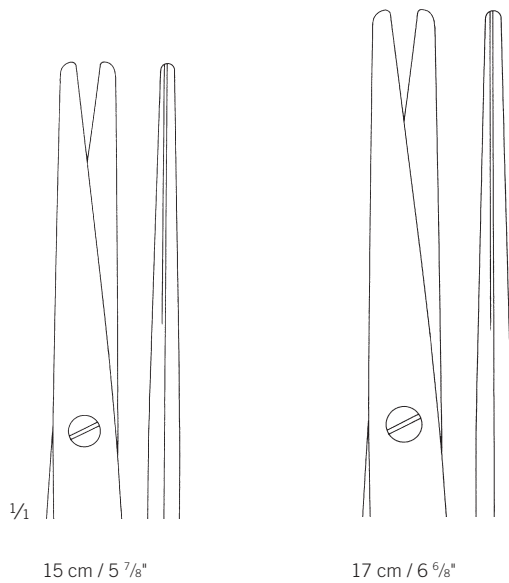

Präparierscheren

Dissecting Scissors
Tijeras de disección
Ciseaux à dissection
Forbici per dissezione

Scheren

Scissors
Tijeras
Ciseaux
Forbici



11



Mayo-Stille	Standard	TCGOLD	SuperCut
15 cm / 5 7/8"	11-181-15-07	11-931-15-07	11-655-15-07
17 cm / 6 6/8"	11-181-17-07	11-931-17-07	11-655-17-07

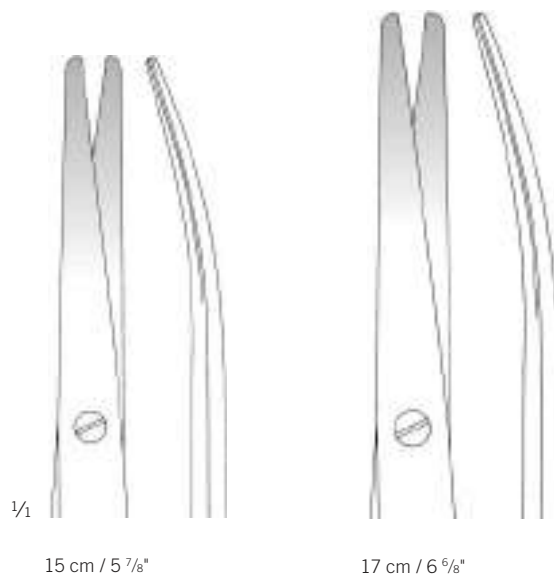

Präparierscheren

Dissecting Scissors
Tijeras de disección
Ciseaux à dissection
Forbici per dissezione

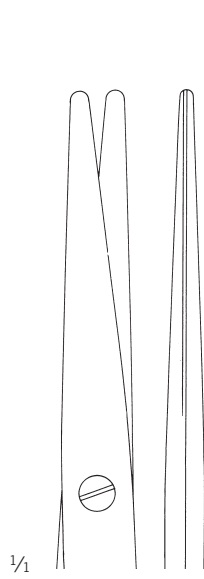

11-184-16-07
16 cm / 6 2/8"

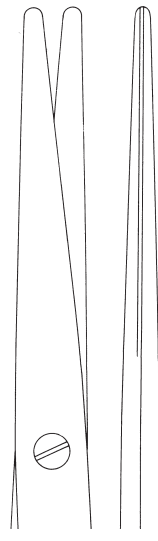

11-184-19-07
19,5 cm / 7 5/8"



11-184-21-07
21,5 cm / 8 4/8"

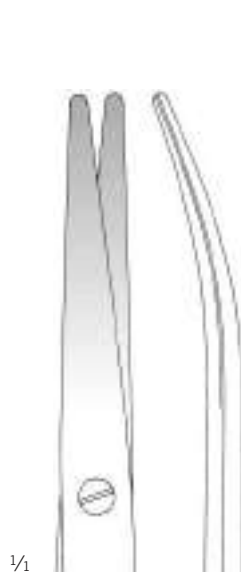

11-185-16-07
16 cm / 6 2/8"

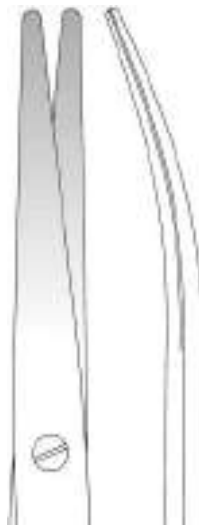

11-185-19-07
19,5 cm / 7 5/8"

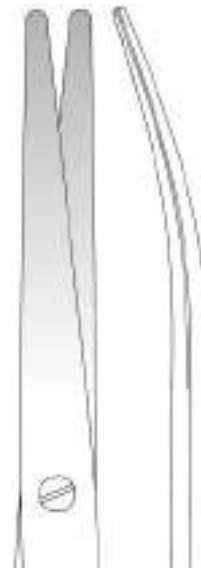

11-185-21-07
21,5 cm / 8 4/8"



Mayo-Stille
11-184-16-07 -
11-185-21-07

Präparierscheren

Dissecting Scissors
Tijeras de disección
Ciseaux à dissection
Forbici per dissezione

Scheren

Scissors
Tijeras
Ciseaux
Forbici



11



11-174-22-07
23 cm / 9"

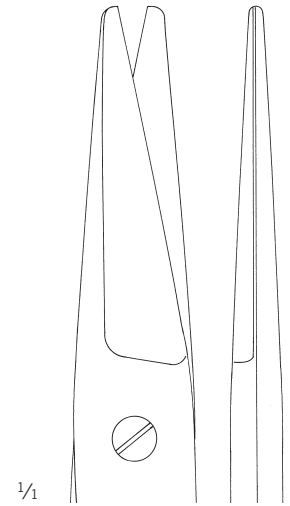

11-190-17-07



1/2

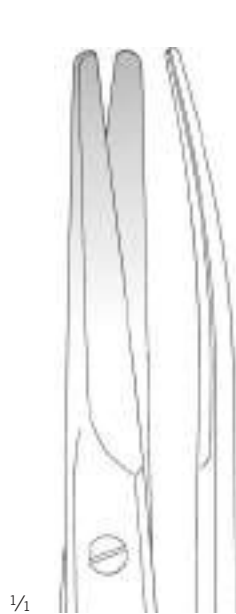

11-175-22-07
23 cm / 9"



11-175-30-07
28 cm / 11"



1/2

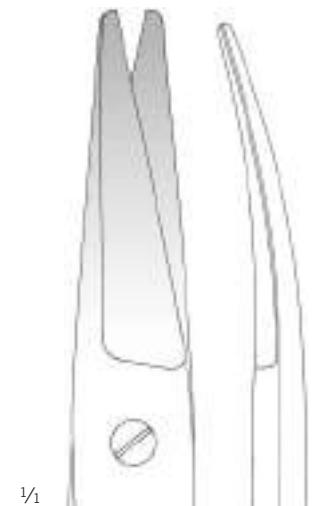

11-191-17-07

Mayo-Harrington
11-174-22-07 -
11-175-30-07

Mayo-Noble
11-190-17-07 -
11-191-17-07
16,5 cm / 6 5/8"

Gynäkologische Scheren

Gynecological Scissors

Tijeras para ginecología

Ciseaux à gynécologie

Forbici per ginecologia



Sims	Standard	TCGOLD
20 cm / 7 7/8"	11-200-20-07	
23 cm / 9"	11-200-23-07	11-976-23-07

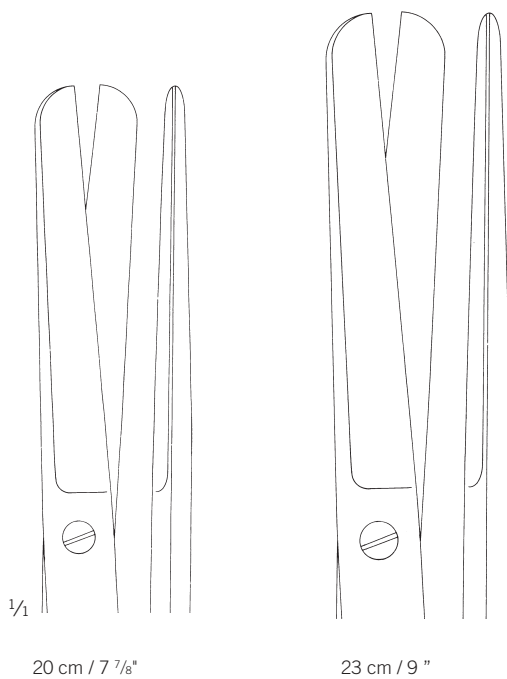

Gynäkologische Scheren

Gynecological Scissors
Tijeras para ginecología
Ciseaux à gynécologie
Forbici per ginecologia

Scheren

Scissors
Tijeras
Ciseaux
Forbici



11

Sims	Standard	TCGOLD	AQUILA	TCCBlackLine
20 cm / 7 7/8"	11-203-20-07		11-975-20-07	11-925-20-07
23 cm / 9"	11-203-23-07	11-977-23-07	11-975-23-07	11-925-23-07

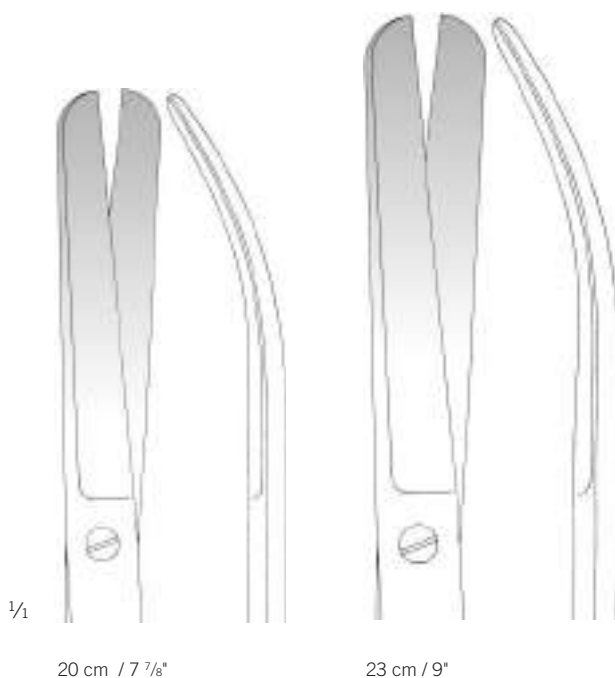

20 cm / 7 7/8"

23 cm / 9"

Chirurgische Scheren

Operating Scissors

Tijeras quirúrgicas

Ciseaux chirurgicaux

Forbici per chirurgia



Kelly	Standard	TCGOLD	SuperCut
16 cm / 6 2/8"	11-226-16-07	11-992-16-07	11-656-16-07

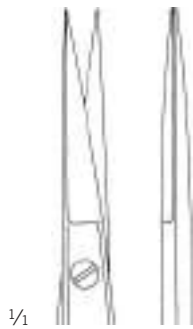

Chirurgische Scheren

Operating Scissors
Tijeras quirúrgicas
Ciseaux chirurgicaux
Forbici per chirurgia

Scheren

Scissors
Tijeras
Ciseaux
Forbici



11



Kelly	Standard	TCGOLD	SuperCut
16 cm / 6 2/8"	11-227-16-07	11-993-16-07	11-657-16-07



Gynäkologische Scheren

Gynecological Scissors

Tijeras para ginecología

Ciseaux à gynécologie

Forbici per ginecologia



1/2

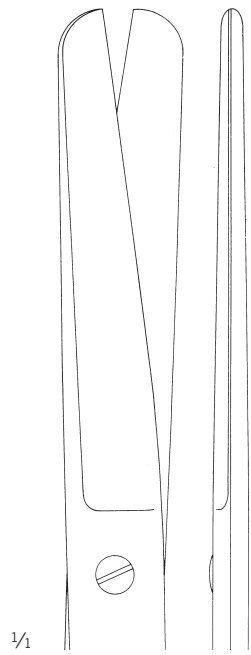

1/1

11-230-17-07

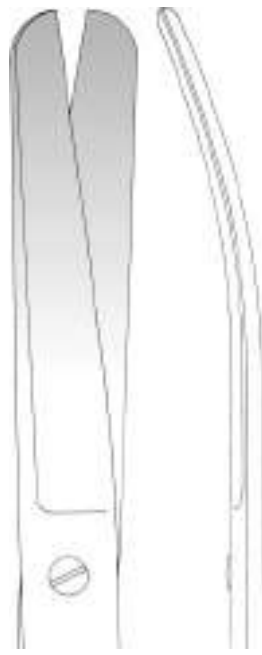

11-231-17-07

Doyen
11-230-17-07 -
11-231-17-07
18,5 cm / 7 2/8"

Gynäkologische Scheren

Gynecological Scissors
Tijeras para ginecología
Ciseaux à gynécologie
Forbici per ginecologia

Scheren

Scissors
Tijeras
Ciseaux
Forbici

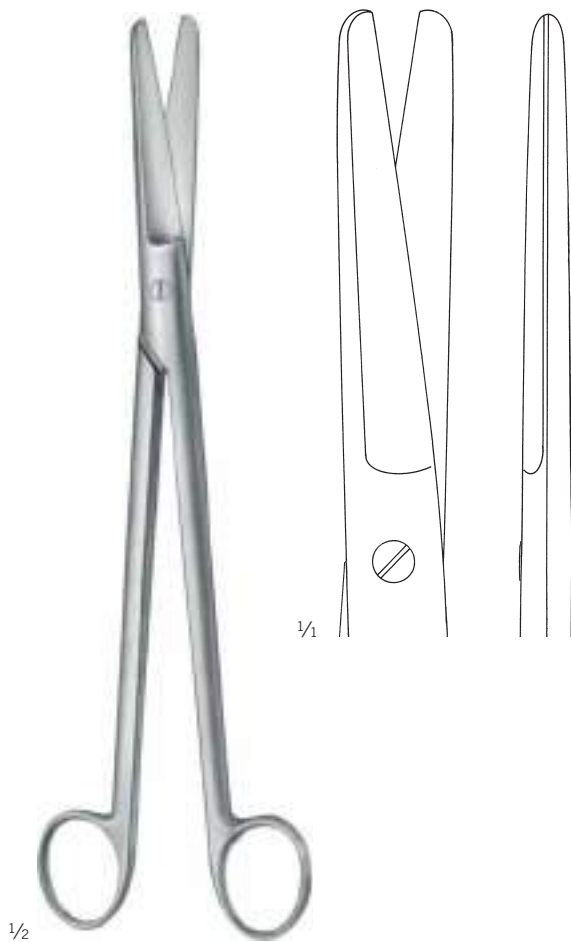

Sims-Siebold
11-232-24-07
24,5 cm / 9 5/8"



Sims-Siebold
11-233-24-07
24,5 cm / 9 5/8"

Gynäkologische Scheren, Präparierscheren

Gynecological Scissors, Dissecting Scissors

Tijeras para ginecología, Tijeras de disección

Ciseaux à gynécologie, Ciseaux à dissection

Forbici per ginecologia, Forbici per dissezione



1/1

11-235-20-07
20 cm / 7 7/8"

11-235-23-07
23 cm / 9"

1/2

Wertheim
11-235-20-07 -
11-235-23-07

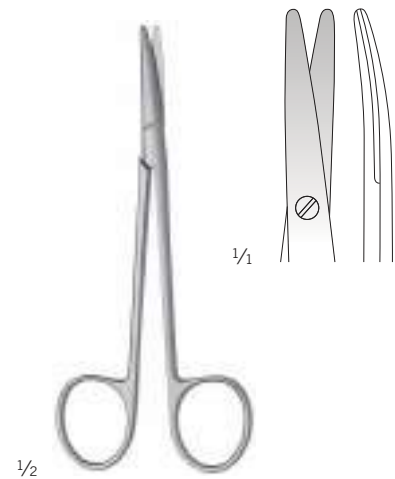

1/1

1/2

Wertheim
11-245-20-07
12 cm / 4 6/8"

Präparierscheren

Dissecting Scissors
Tijeras de disección
Ciseaux à dissection
Forbici per dissezione

Scheren

Scissors
Tijeras
Ciseaux
Forbici



Metzenbaum	Standard	TCGOLD	SuperCut
11,5 cm / 4 5/8"	11-248-11-07	11-936-11-07	11-658-11-07



Präparierscheren

Dissecting Scissors
Tijeras de disección
Ciseaux à dissection
Forbici per dissezione



Metzenbaum	Standard	TCGOLD	SuperCut
11,5 cm / 4 5/8"	11-249-11-07	11-937-11-07	11-659-11-07

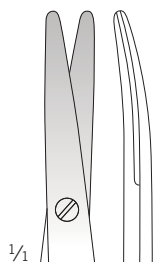

Präparierscheren

Dissecting Scissors
Tijeras de disección
Ciseaux à dissection
Forbici per dissezione

Scheren

Scissors
Tijeras
Ciseaux
Forbici



Metzenbaum	 AQUILA	TCCBlackLine
11,5 cm / 4 5/8"	11-887-11-07	11-917-11-07

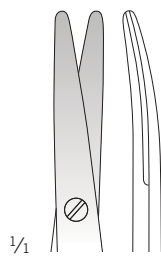

Präparierscheren

Dissecting Scissors
 Tijeras de disección
 Ciseaux à dissection
 Forbici per dissezione



Metzenbaum	Standard	TCGOLD	SuperCut
14,5 cm / 5 7/8"	11-250-14-07	11-938-14-07	11-658-14-07



Präparierscheren

Dissecting Scissors

Tijeras de disección

Ciseaux à dissection

Forbici per dissezione

Scheren

Scissors

Tijeras

Ciseaux

Forbici



Metzenbaum	Standard	TCGOLD	SuperCut
14,5 cm / 5 7/8"	11-255-14-07	11-939-14-07	11-659-14-07



Präparierscheren

Dissecting Scissors
 Tijeras de disección
 Ciseaux à dissection
 Forbici per dissezione



1/2

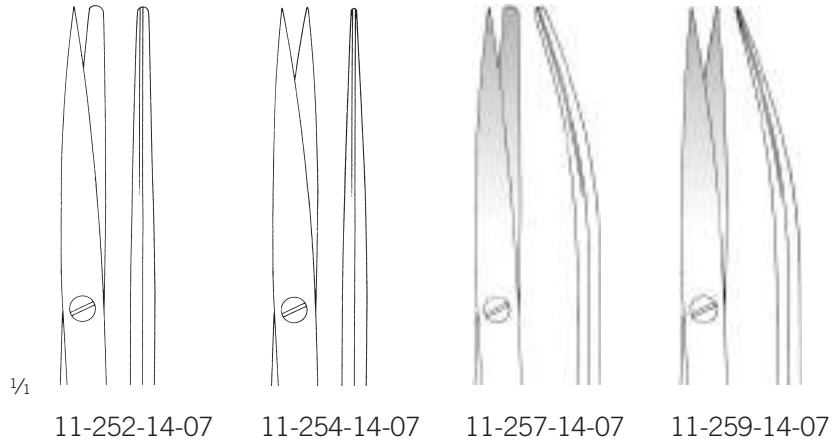

1/1

11-252-14-07

11-254-14-07

11-257-14-07

11-259-14-07

Metzenbaum
 11-252-14-07 -
 11-259-14-07
 14,5 cm / 5 7/8"



1/2

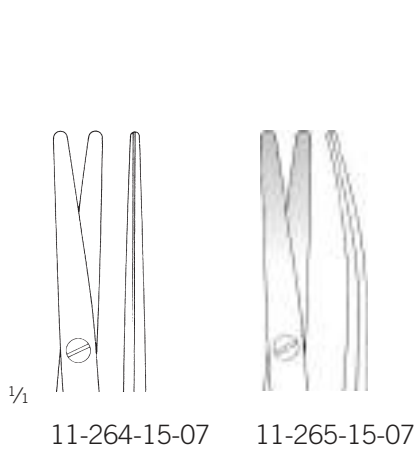

1/1

11-264-15-07

11-265-15-07

Metzenbaum
 11-264-15-07 -
 11-265-15-07
 15,5 cm / 6 1/8"



1/2

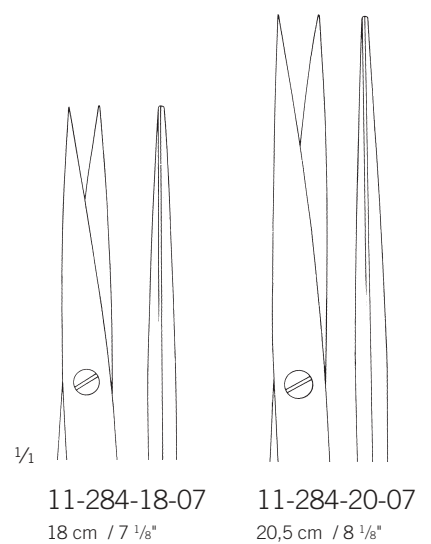

1/1

11-284-18-07
 18 cm / 7 1/8"

11-284-20-07
 20,5 cm / 8 1/8"

Metzenbaum-Nelson
 11-284-18-07 -
 11-284-20-07

Präparierscheren

Dissecting Scissors
Tijeras de disección
Ciseaux à dissection
Forbici per dissezione

Scheren

Scissors
Tijeras
Ciseaux
Forbici



11

Metzenbaum	Standard	TCGOLD	SuperCut
18 cm / 7 1/8"	11-280-18-07	11-942-18-07	11-660-18-07
20,5 cm / 8 1/8"	11-280-20-07	11-942-20-07	11-660-20-07
23 cm / 9"	11-280-23-07	11-942-23-07	11-660-23-07
26 cm / 10 2/8"	11-280-25-07	11-942-25-07	11-660-26-07
28,5 cm / 11 2/8"	11-280-28-07	11-942-28-07	11-660-28-07
31 cm / 12 2/8"	11-280-30-07	11-942-30-07	11-660-31-07

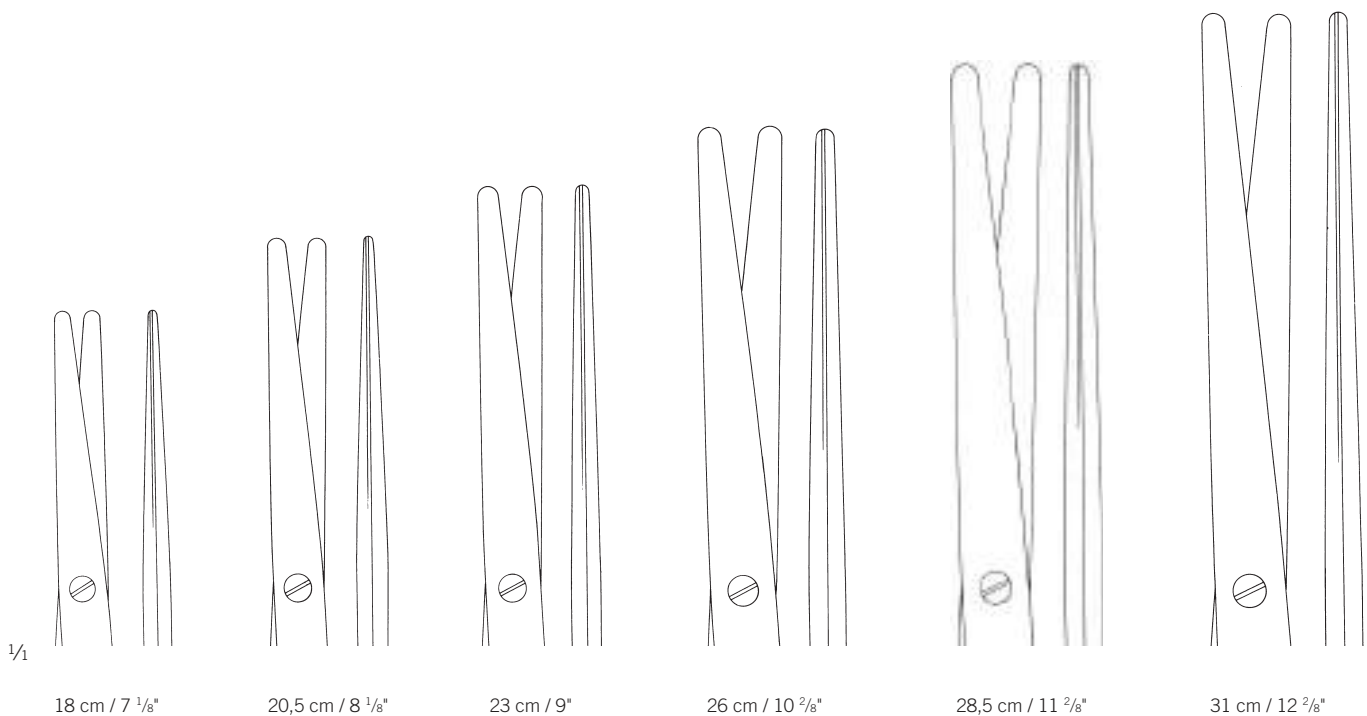

18 cm / 7 1/8"

20,5 cm / 8 1/8"

23 cm / 9"

26 cm / 10 2/8"

28,5 cm / 11 2/8"

31 cm / 12 2/8"

Präparierscheren

Dissecting Scissors
 Tijeras de disección
 Ciseaux à dissection
 Forbici per dissezione



Metzenbaum	Standard	TCGOLD	SuperCut
18 cm / 7 1/8"	11-285-18-07	11-943-18-07	11-661-18-07
20,5 cm / 8 1/8"	11-285-20-07	11-943-20-07	11-661-20-07
23 cm / 9"	11-285-23-07	11-943-23-07	11-661-23-07
26 cm / 10 2/8"	11-285-25-07	11-943-25-07	11-661-26-07
28,5 cm / 11 2/8"	11-285-28-07	11-943-28-07	11-661-28-07
31 cm / 12 2/8"	11-285-30-07	11-943-30-07	11-661-31-07

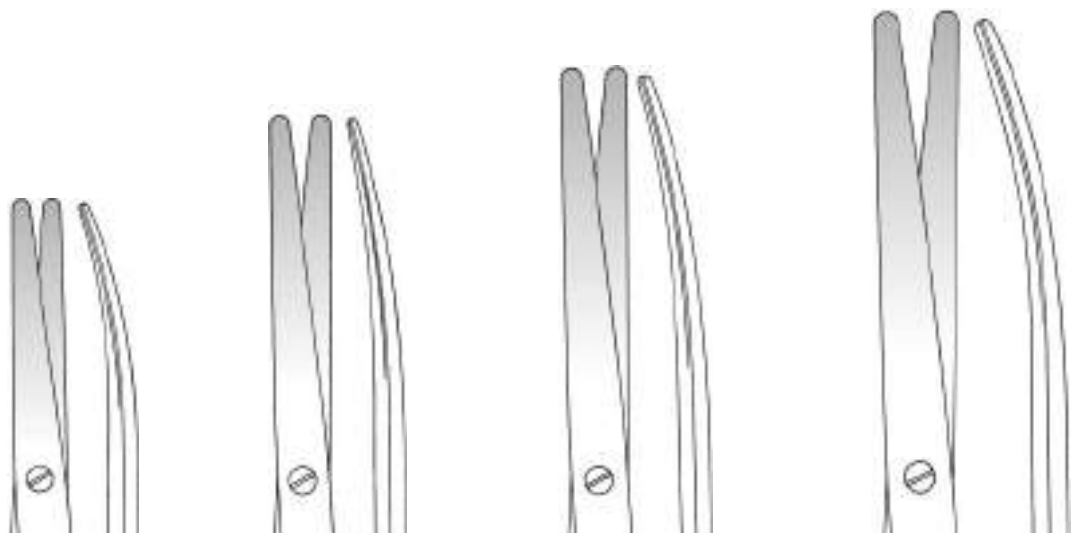

18 cm / 7 1/8"

20,5 cm / 8 1/8"

23 cm / 9"

26 cm / 10 2/8"

Präparierscheren

Dissecting Scissors
Tijeras de disección
Ciseaux à dissection
Forbici per dissezione

Scheren

Scissors
Tijeras
Ciseaux
Forbici



11

Metzenbaum	 AQUILA	TCCBlackLine
18 cm / 7 1/8"	11-887-18-07	11-917-18-07
20,5 cm / 8 1/8"	11-887-20-07	11-917-20-07
23 cm / 9"	11-887-23-07	11-917-23-07
26 cm / 10 2/8"	11-887-25-07	11-917-25-07
31 cm / 12 2/8"	11-887-30-07	11-917-30-07

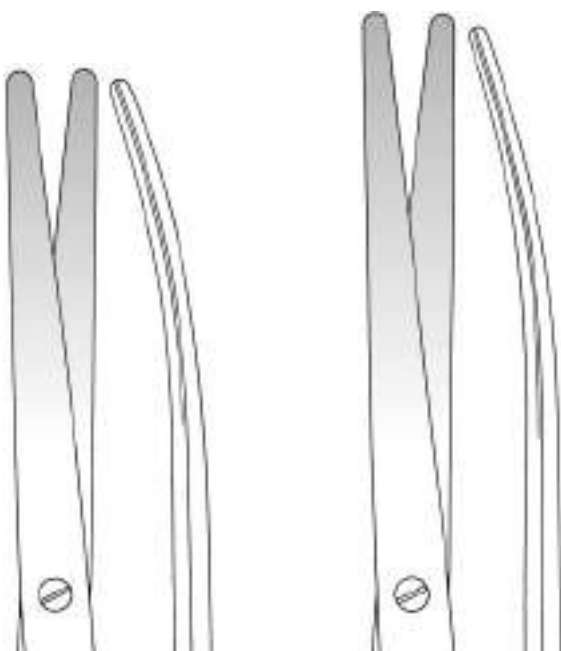

28,5 cm / 11 2/8"

31 cm / 12 2/8"

Präparierscheren

Dissecting Scissors
Tijeras de disección
Ciseaux à dissection
Forbici per dissezione



Metzenbaum

11-298-14-07-

11-299-14-07

14,5 cm / 5 7/8"

eine Schneide gezahnt
one toothed cutting edge
una hoja dentada
une lame dentelée
una lama dentata



11-300-15-07 -

11-301-15-07

15,5 cm / 6 1/8"

Nerv-Präparierschere
Nerve Dissecting Scissors
Tijeras para disección de nervios
Ciseaux pour nerfs
Forbici per nervi

Präparierscheren

Dissecting Scissors
Tijeras de disección
Ciseaux à dissection
Forbici per dissezione

Scheren

Scissors
Tijeras
Ciseaux
Forbici



Kaye

11-305-00-07

18,5 cm / 7 ²/₈"

beide Schneiden gezahnt
both cutting edges serrated
ambos filos dentados
deux lames dentées
entrambe le lame dentate



Gorney

11-306-12-07 -

11-308-17-07

beide Schneiden gezahnt
both cutting edges serrated
ambos filos dentados
deux lames dentées
entrambe le lame dentate

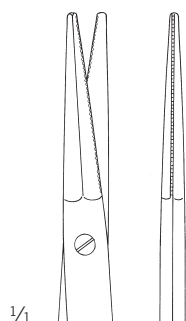

11-306-12-07
12,5 cm / 4 ⁷/₈"

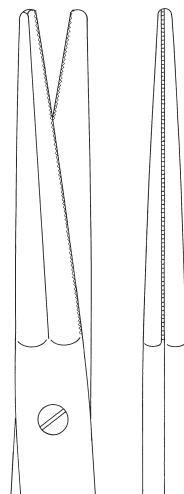

11-306-19-07
19,5 cm / 7 ⁵/₈"

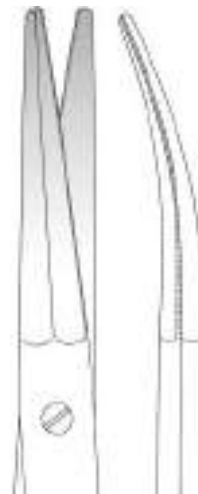

11-307-19-07
19,5 cm / 7 ⁵/₈"

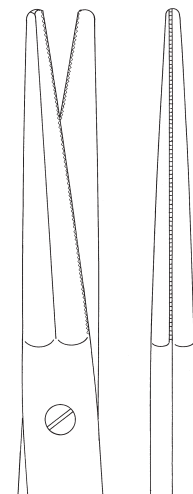

11-308-17-07
17 cm / 6 ⁶/₈"

Präparierscheren

Dissecting Scissors
 Tijeras de disección
 Ciseaux à dissection
 Forbici per dissezione



Lexer	Standard	TCGOLD	SuperCut
16 cm / 6 2/8"	11-311-16-07	11-951-16-07	11-663-16-07

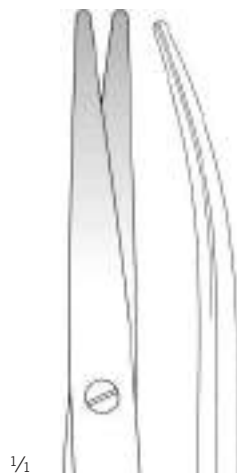

Präparierscheren

Dissecting Scissors
Tijeras de disección
Ciseaux à dissection
Forbici per dissezione

Scheren

Scissors
Tijeras
Ciseaux
Forbici



Lexer	 AQUILA	TCCBlackLine
16 cm / 6 2/8"	11-895-16-07	11-923-16-07

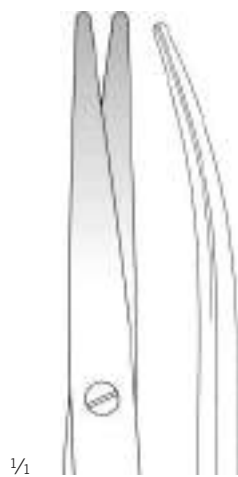

11

Präparierscheren

Dissecting Scissors
 Tijeras de disección
 Ciseaux à dissection
 Forbici per dissezione



Lexer	Standard	TCGOLD	SuperCut
16 cm / 6 2/8"	11-310-16-07	11-950-16-07	11-662-16-07

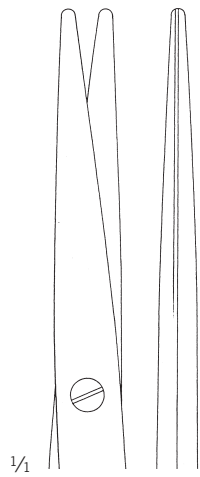

Präparierscheren

Dissecting Scissors
 Tijeras de disección
 Ciseaux à dissection
 Forbici per dissezione

Scheren

Scissors
 Tijeras
 Ciseaux
 Forbici



11

Hohenfellner	Standard	TCGOLD
18 cm / 7 1/8"	11-313-18-07	11-314-18-07
21 cm / 8 2/8"	11-313-21-07	11-314-21-07
24 cm / 9 4/8"	11-313-24-07	11-314-24-07

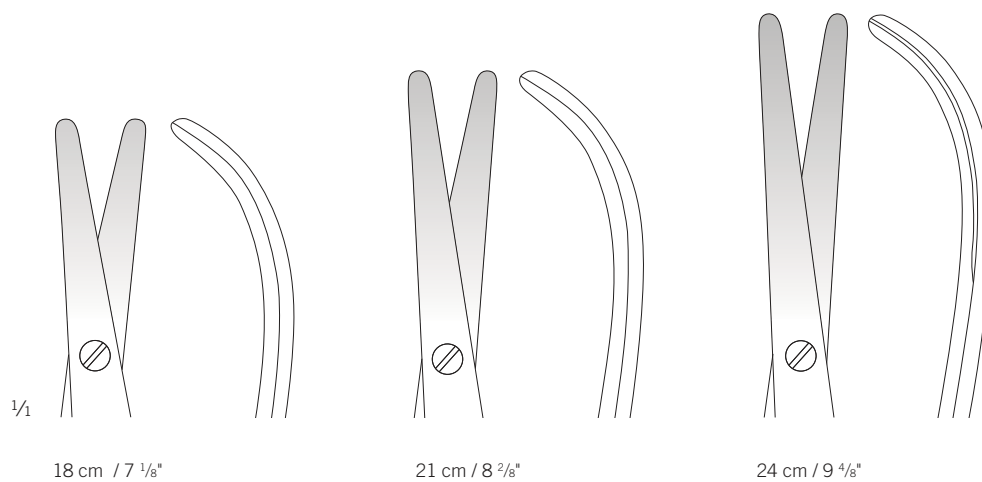

Präparierscheren

Dissecting Scissors
 Tijeras de disección
 Ciseaux à dissection
 Forbici per dissezione



DeBakey	Standard	TCGOLD
17,5 cm / 6 7/8"	11-315-17-07	11-316-17-07
20 cm / 7 7/8"	11-315-20-07	11-316-20-07

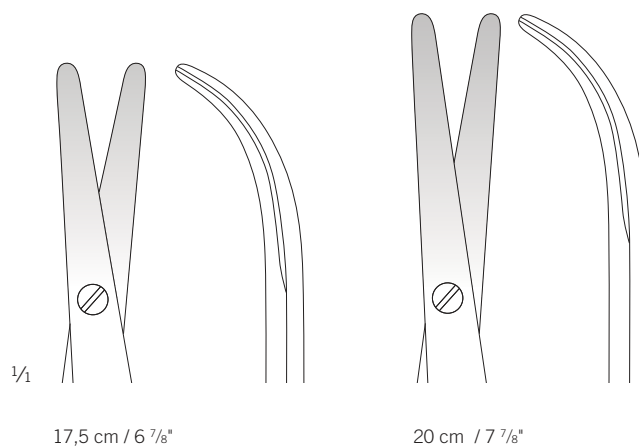

17,5 cm / 6 7/8"

20 cm / 7 7/8"

Präparierscheren

Dissecting Scissors
Tijeras de disección
Ciseaux à dissection
Forbici per dissezione

Scheren

Scissors
Tijeras
Ciseaux
Forbici

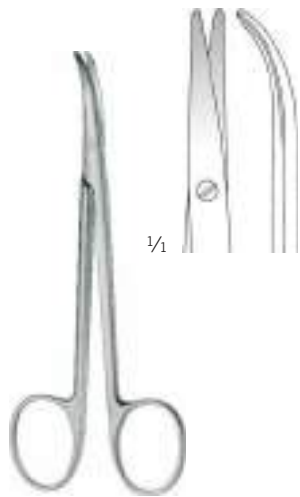

1/2

Cinelli
11-317-11-07
11,5 cm / 4 5/8"

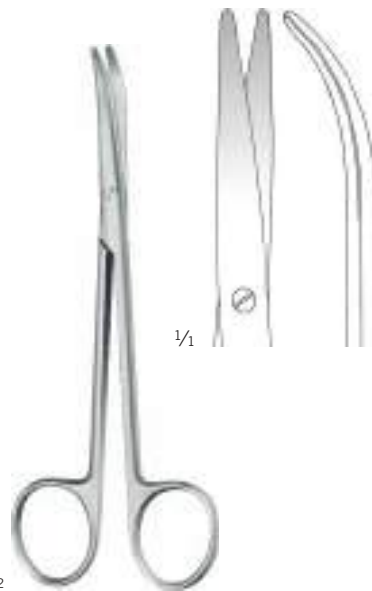

1/2

Fomon
11-317-14-07
14 cm / 5 4/8"



1/2

Thorek
11-319-19-07
18,5 cm / 7 2/8"

Präparierscheren

Dissecting Scissors
 Tijeras de disección
 Ciseaux à dissection
 Forbici per dissezione



Lexer-Baby	Standard	SuperCut
10 cm / 3 7/8"	11-320-10-07	11-662-10-07

Standard	SuperCut
11-321-10-07	11-663-10-07

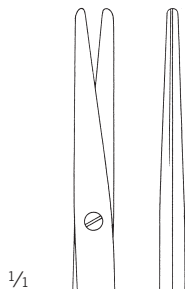

Präparierscheren

Dissecting Scissors
Tijeras de disección
Ciseaux à dissection
Forbici per dissezione

Scheren

Scissors
Tijeras
Ciseaux
Forbici



finoLine

11

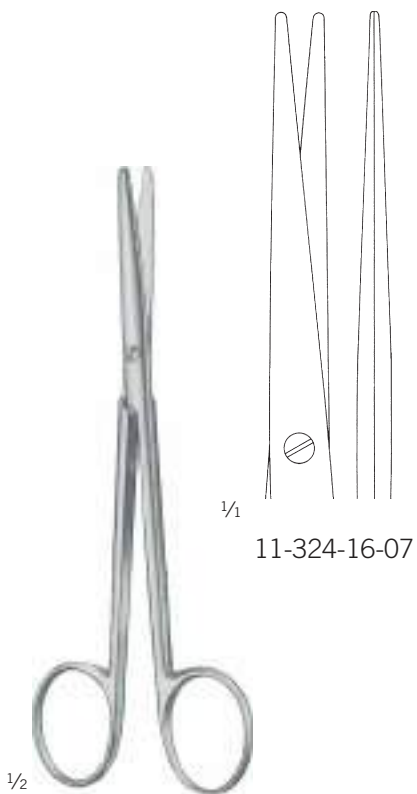

11-324-16-07

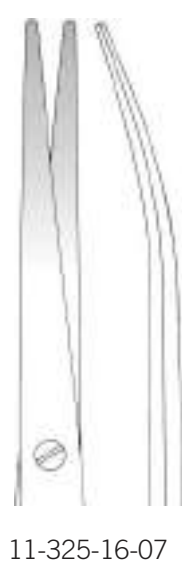

11-325-16-07

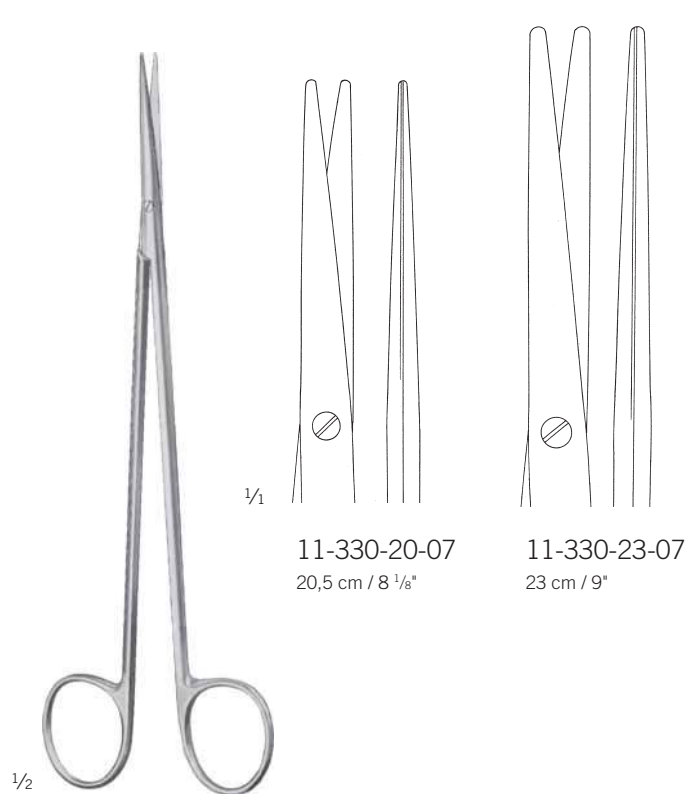

11-330-20-07
20,5 cm / 8 1/8"

11-330-23-07
23 cm / 9"

Lexer-Fino
11-324-16-07 -
11-325-16-07
16,5 cm / 6 1/8"
schlankes Modell
slender pattern
modelo delgado
modèle gracile
modello delicato

Metzenbaum-Fino
11-330-20-07 -
11-330-23-07
schlankes Modell
slender pattern
modelo delgado
modèle gracile
modello delicato

Feine Präparierscheren

Delicate Dissecting Scissors

Tijeras finas de disección

Ciseaux fins à dissection

Forbici fini per dissezione

finoLine



Metzenbaum-Fino	Standard	TCGOLD
14,5 cm / 5 7/8"	11-326-14-07	11-954-14-07



schlankes Modell
slender pattern
modelo delgado
modèle gracile
modello delicato

Feine Präparierscheren

Delicate Dissecting Scissors

Tijeras finas de disección

Ciseaux fins à dissection

Forbici fini per dissezione

Scheren

Scissors

Tijeras

Ciseaux

Forbici



finoLine



11

Metzenbaum-Fino	Standard	TCGOLD	SuperCut	AQUILA
14,5 cm / 5 9/16"	11-327-14-07	11-955-14-07	11-665-14-07	11-889-14-07



schlankes Modell
slender pattern
modelo delgado
modèle gracile
modello delicato

Feine Präparierscheren

Delicate Dissecting Scissors

Tijeras finas de disección

Ciseaux fins à dissection

Forbici fini per dissezione

finoLine



Metzenbaum-Fino	Standard	TCGOLD
14,5 cm / 5 6/8"	11-328-14-07	11-956-14-07

Standard	TCGOLD
11-329-14-07	11-957-14-07



schlankes Modell
slender pattern
modelo delgado
modèle gracile
modello delicato



schlankes Modell
slender pattern
modelo delgado
modèle gracile
modello delicato

Feine Präparierscheren

Delicate Dissecting Scissors

Tijeras finas de disección

Ciseaux fins à dissection

Forbici fini per dissezione

Scheren

Scissors

Tijeras

Ciseaux

Forbici



finoLine



Metzenbaum-Fino	Standard	TCGOLD
18 cm / 7 1/8"	11-330-18-07	11-960-18-07

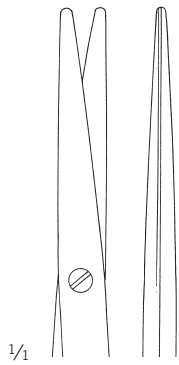

11

Feine Präparierscheren

Delicate Dissecting Scissors

Tijeras finas de disección

Ciseaux fins à dissection

Forbici fini per dissezione

finoLine



Metzenbaum-Fino	Standard	TCGOLD	SuperCut	AQUILA
18 cm / 7 1/8"	11-331-18-07	11-961-18-07	11-665-18-07	11-889-18-07
20,5 cm / 8 1/8"	11-331-20-07	11-961-20-07	11-665-20-07	
23 cm / 9"	11-331-23-07	11-961-23-07	11-665-23-07	

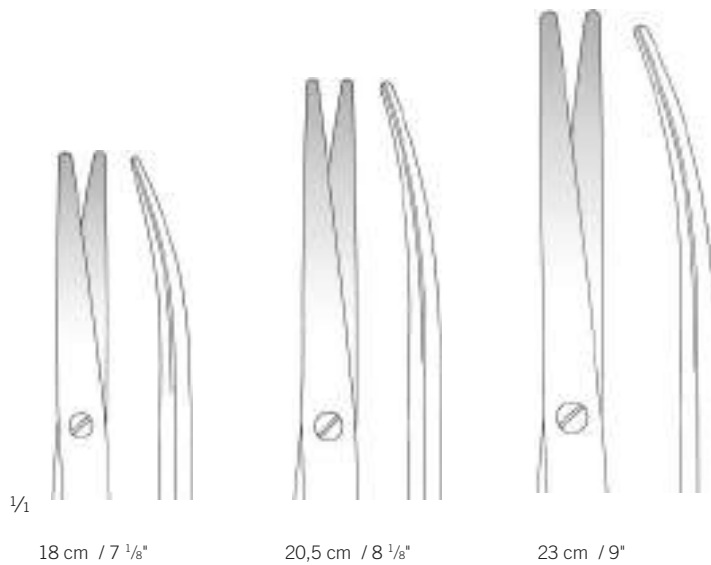

18 cm / 7 1/8"

20,5 cm / 8 1/8"

23 cm / 9"

Feine Präparierscheren

Delicate Dissecting Scissors

Tijeras finas de disección

Ciseaux fins à dissection

Forbici fini per dissezione

Scheren

Scissors

Tijeras

Ciseaux

Forbici



finoLine



1/2

1/2

TC GOLD

11

Metzenbaum-Fino	Standard	TC GOLD
18 cm / 7 1/8"	11-335-18-07	11-967-18-07
20,5 cm / 8 1/8"	11-335-20-07	11-967-20-07
23 cm / 9"	11-335-23-07	11-967-23-07

schlankes Modell, S-Form
slender pattern, S-shaped
modelo delgado, forma S
modèle gracile, courbé en S
modello delicato, curvo in forma S

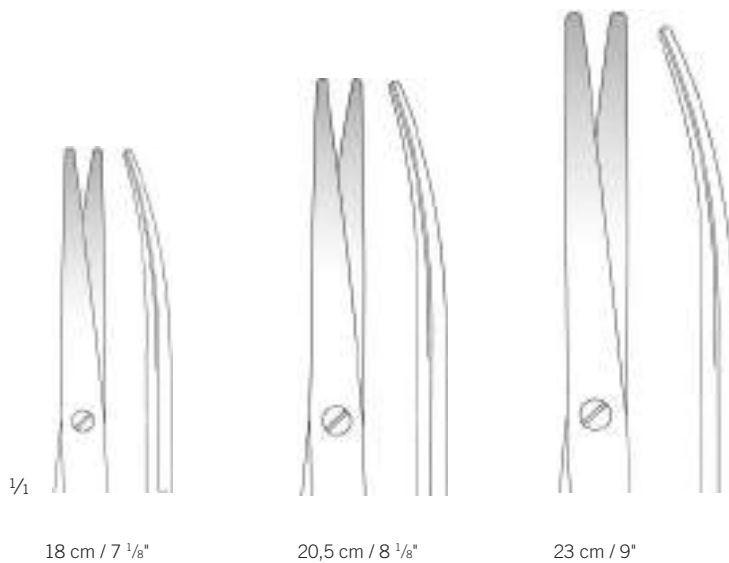

1/1

18 cm / 7 1/8"

20,5 cm / 8 1/8"

23 cm / 9"

Präparierscheren, Chirurgische Scheren

Dissecting Scissors, Operating Scissors

Tijeras de disección, Tijeras quirúrgicas

Ciseaux à dissection, Ciseaux chirurgicaux

Forbici per dissezione, Forbici per chirurgia



1/4



11-339-12-07
12,5 cm / 4 7/8"

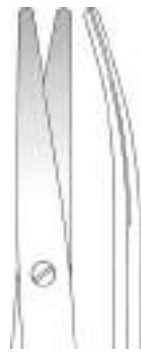

11-339-18-07
18 cm / 7 1/8"



1/2

1/4

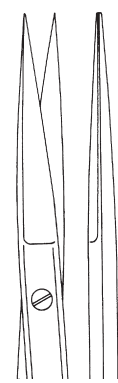

11-340-14-07

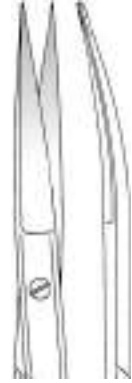

11-341-14-07
14 cm / 5 4/8"

Salyer

11-339-12-07 -
11-339-18-07

feines Modell, eine Schneide mit Messerschliff
delicate pattern, one cutting edge with knife cut
modelo delicado, una hoja con afilado de cuchillo
modèle fin, une lame avec taille de couteau
modello fino, una lama con affilatura di coltello

für Lippen-, Kiefer-, Gaumenspalte
for Cleft Palate
para fisura paladar
pour fente du palais
per cheilo-labbro-palato schisi

Sanvenero

11-340-14-07 -
11-341-14-07

14 cm / 5 4/8"



1/2

1/4



11-344-11-07



11-345-11-07

11-344-11-07 -
11-345-11-07

11 cm / 4 3/8"

Chirurgische Scheren

Operating Scissors
Tijeras quirúrgicas
Ciseaux chirurgicaux
Forbici per chirurgia

Scheren

Scissors
Tijeras
Ciseaux
Forbici



Joseph	Standard	TCGOLD	SuperCut
14,5 cm / 5 7/8"	11-350-14-07	11-948-14-07	11-666-14-07

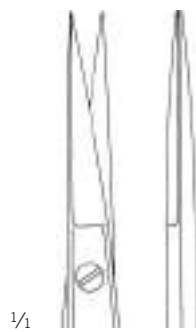

Chirurgische Scheren

Operating Scissors

Tijeras quirúrgicas

Ciseaux chirurgicaux

Forbici per chirurgia



Joseph	Standard	TCGOLD	SuperCut
14,5 cm / 5 7/8"	11-351-14-07	11-949-14-07	11-667-14-07

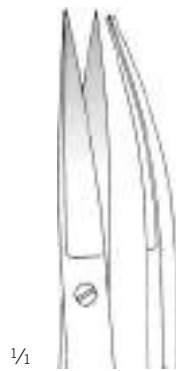

Face-lift-Scheren, Präparierscheren

Face-lift Scissors, Dissecting Scissors

Tijeras para Face-lift, Tijeras de disección

Ciseaux pour Face-lift, Ciseaux à dissection

Forbici per Face-lift, Forbici per dissezione

Scheren

Scissors

Tijeras

Ciseaux

Forbici



11

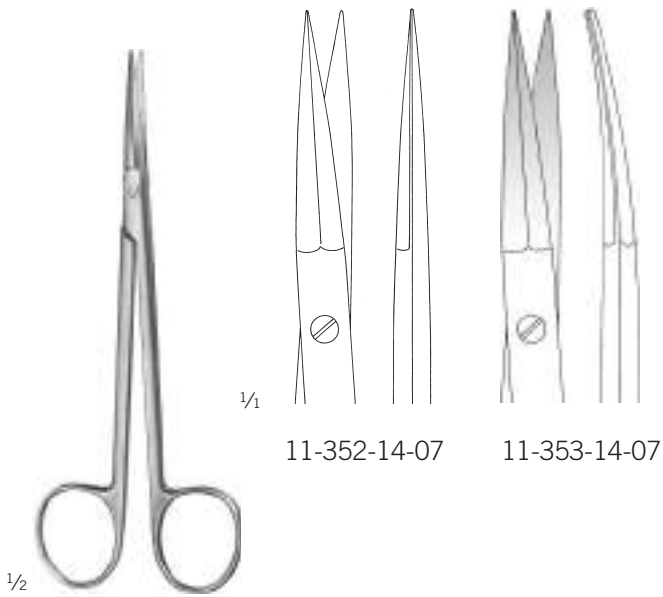

Peck-Joseph
11-352-14-07 -
11-353-14-07
14,5 cm / 5 7/8"



Peck-Joseph
11-354-14-07 -
11-355-14-07
14,5 cm / 5 7/8"



Shea Vein Graft
11-357-12-07
12 cm / 4 7/8"



11-358-13-07
13 cm / 5 1/8"
Dissektions- u. Zahnfleischschere
Dissecting Scissors
Tijera de disección
Ciseaux à dissection
Forbici per dissezione

Face-lift-Scheren, Präparierscheren

Face-lift Scissors, Dissecting Scissors

Tijeras para Face-lift, Tijeras de disección

Ciseaux pour Face-lift, Ciseaux à dissection

Forbici per Face-lift, Forbici per dissezione



Kilner	Standard	SuperCut
12 cm / 4 5/8"	11-359-12-07	11-669-12-07
15 cm / 5 7/8"	11-359-15-07	11-669-15-07

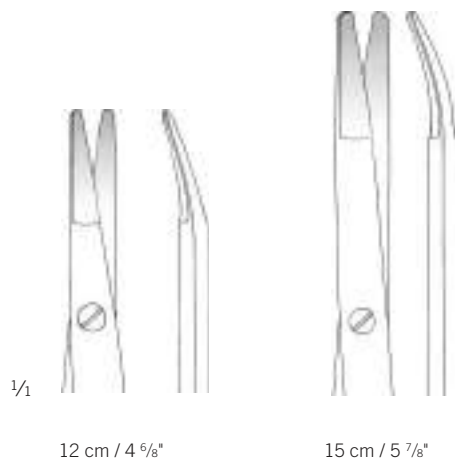

12 cm / 4 5/8"

15 cm / 5 7/8"

Präparierscheren, Gefäßscheren

Dissecting Scissors, Vascular Scissors
 Tijeras de disección, Tijeras vasculares
 Ciseaux à dissection, Ciseaux vasculaires
 Forbici per dissezione, Forbici vascolari

Scheren

Scissors
 Tijeras
 Ciseaux
 Forbici

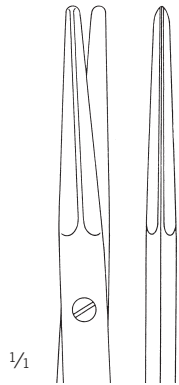

11-362-14-07



11-363-14-07



Reynolds
 11-364-15-07
 15,5 cm / 6 1/8"



Jameson
 11-367-14-07
 15,5 cm / 6 1/8"



Jameson
 11-369-14-07
 15,5 cm / 6 1/8"
 eine Schneide gezahnt
 one toothed cutting edge
 una hoja dentada
 une lame dentelée
 una lama dentata

Präparierscheren, Gefäßscheren

Dissecting Scissors, Vascular Scissors

Tijeras de disección, Tijeras vasculares

Ciseaux à dissection, Ciseaux vasculaires

Forbici per dissezione, Forbici vascolari



Reynolds	Standard	SuperCut
15,5 cm / 6 1/8"	11-365-15-07	11-671-15-07
18 cm / 7 1/8"	11-365-18-07	11-671-18-07



Kurze Mikroscheren

Short Micro Scissors
 Micro-Tijeras, corto
 Micro-Ciseaux, court
 Micro-Forbici, corto

Scheren

Scissors
 Tijeras
 Ciseaux
 Forbici



11



1/2

11-370-01-07 -
 11-371-04-07
 12 cm / 4 5/8"



 safety-wave 12 cm / 4 5/8"		A spitz/spitz sharp/sharp agudo/agudo pointu/pointu appuntato/appuntato	A spitz/spitz sharp/sharp agudo/agudo pointu/pointu appuntato/appuntato	spitz/stumpf sharp/blunt agudo/romo pointu/mousse appuntato/smusso	D stumpf/stumpf blunt/blunt romo/romo mousse/mousse smusso/smusso	mit Knopf with button con botón avec bouton con bottone
		7 mm	7 mm	7 mm	7 mm	7 mm
		11-370-01-07	11-371-01-07	11-371-02-07	11-371-03-07	11-371-04-07



1/2

11-370-02-07 -
 11-371-08-07
 12 cm / 4 5/8"



 safety-wave 12 cm / 4 5/8"		A spitz/spitz sharp/sharp agudo/agudo pointu/pointu appuntato/appuntato	A spitz/spitz sharp/sharp agudo/agudo pointu/pointu appuntato/appuntato	spitz/stumpf sharp/blunt agudo/romo pointu/mousse appuntato/smusso	D stumpf/stumpf blunt/blunt romo/romo mousse/mousse smusso/smusso	mit Knopf with button con botón avec bouton con bottone
		7 mm	7 mm	7 mm	7 mm	7 mm
		11-370-02-07	11-371-05-07	11-371-06-07	11-371-07-07	11-371-08-07

A = Adventitia
 D = Präparation
 A-SB = Adventitia, ein gezahntes Blatt
 D-SB = Präparation, ein gezahntes Blatt

A = Adventitia
 D = Dissection
 A-SB = Adventitia, one serrated blade
 D-SB = Dissection, one serrated blade

A = Adventicia
 D = Disección
 A-SB = Adventicia, una hoja dentada
 D-SB = Disección, una hoja dentada

A = Advantice
 D = Dissection
 A-SB = Advantice, une lame dentelée
 D-SB = Dissection, une lame dentelée

A = Avventizia
 D = Dissezione
 A-SB = Avventizia, una lama dentata
 D-SB = Dissezione, una lama dentata

Präparierscheren, Gefäßscheren

Dissecting Scissors, Vascular Scissors

Tijeras de disección, Tijeras vasculares

Ciseaux à dissection, Ciseaux vasculaires

Forbici per dissezione, Forbici vascolari

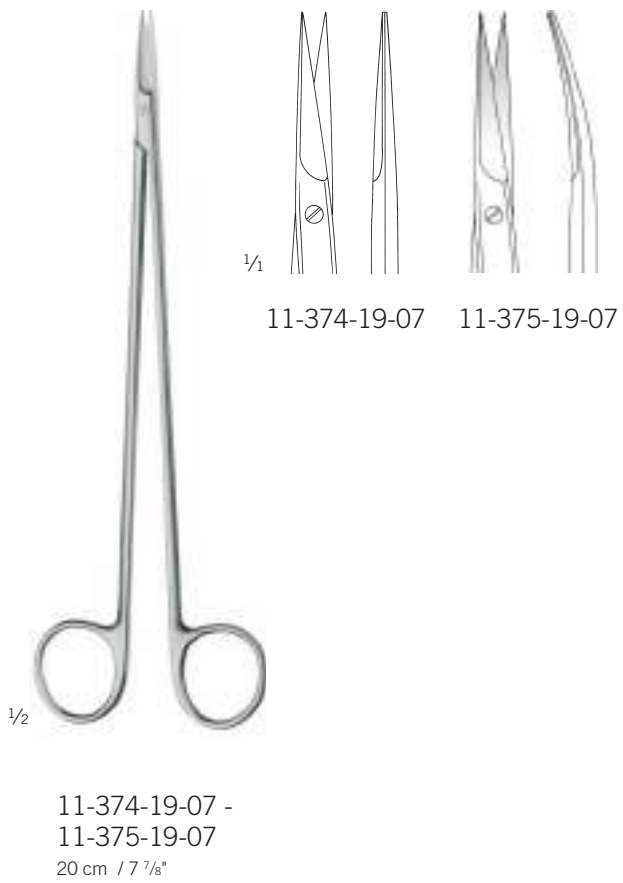

Gefäßscheren, Koronarscheren

Vascular Scissors, Coronary Scissors

Tijeras vasculares, Tijeras coronarias

Ciseaux vasculaires, Ciseaux coronaires

Forbici vascolari, Forbici per arteria coronaria

Scheren

Scissors

Tijeras

Ciseaux

Forbici



1/2

Diethrich
11-380-25-07 -
11-381-00-07

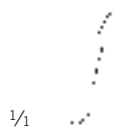

1/4

11-380-25-07
19 cm / 7 4/8"



10 mm

25°

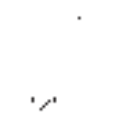

1/4

11-380-45-07
18,5 cm / 7 2/8"



10 mm

45°

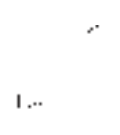

1/4

11-380-60-07
17,5 cm / 6 7/8"



10 mm

60°

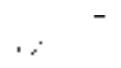

11-380-90-07
17,5 cm / 6 7/8"



10 mm

90°

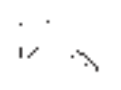

11-381-00-07
17,5 cm / 6 7/8"



10 mm

125°



1/2

Diethrich
11-381-01-07
17,5 cm / 6 7/8"



1/4



10 mm

125°

mit Führung
with guidance
con guiado
avec guide
con guida

Gefäßscheren, Koronarscheren

Vascular Scissors, Coronary Scissors

Tijeras vasculares, Tijeras coronarias

Ciseaux vasculaires, Ciseaux coronaires

Forbici vascolari, Forbici per arteria coronaria



1/2

Mikro-Hegemann
11-382-25-07 -
11-383-01-07
18,5 cm / 7 2/8"

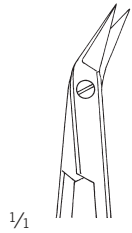

1/4

11-382-25-07



7 mm

25°



11-382-45-07



7 mm

45°

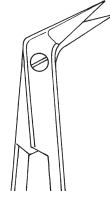

11-382-60-07



7 mm

60°

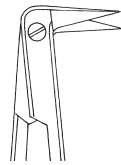

11-382-90-07



7 mm

90°



11-383-01-07



7 mm

125°



1/2

De Bakey
11-390-45-07 -
11-390-60-07
16 cm / 6 2/8"

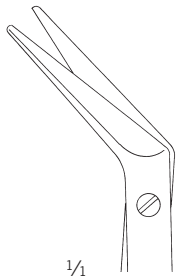

1/4

11-390-45-07

45°

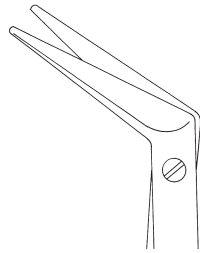

11-390-60-07

60°

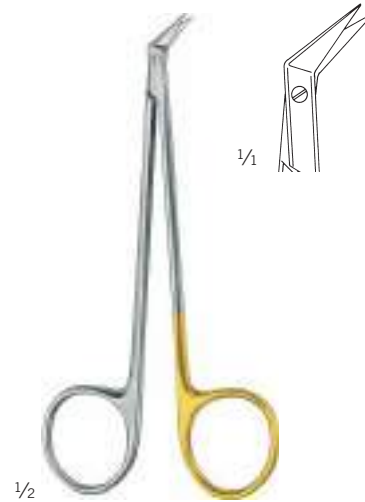

1/2

Diethrich-Salyer
11-379-45-07

12 cm / 4 5/8"

ein Blatt mit Messerschiff
one cutting edge with knife cut
una hoja con afilado de cuchillo
une lame avec taille de couteau
una lama con affilatura di coltello

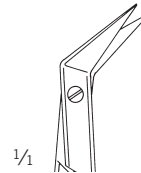

1/4

für Lippen-, Kiefer-, Gaumenspalte
for Cleft Palate
para fisura paladar
pour fente du palais
per cheilo-labbro-palato schisi

Gefäßscheren

Vascular Scissors
Tijeras vasculares
Ciseaux vasculaires
Forbici vascolari

Scheren

Scissors
Tijeras
Ciseaux
Forbici



11



1/2

Potts-Smith
11-391-19-07 -
11-397-19-07

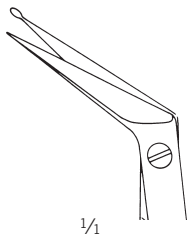

1/4

11-391-19-07

18 cm / 7 1/8"

60°

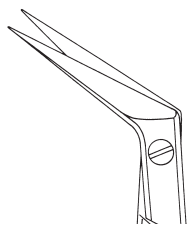

11-393-19-07

18 cm / 7 1/8"

60°

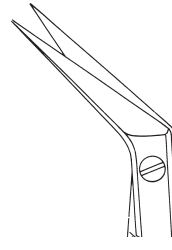

11-394-19-07

18,5 cm / 7 2/8"

40°

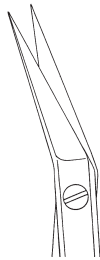

11-395-19-07

19 cm / 7 4/8"

25°



11-397-19-07

19,5 cm / 7 5/8"



1/2

Potts-Smith
11-396-19-07 -
11-399-19-07

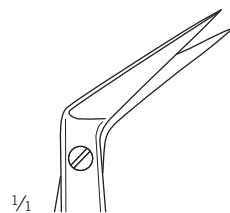

1/4

11-396-19-07

18 cm / 7 1/8"

60°

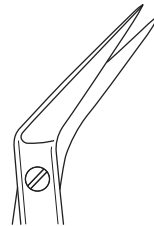

11-398-19-07

18,5 cm / 7 2/8"

40°



11-399-19-07

19 cm / 7 4/8"

25°

Gefäßscheren

Vascular Scissors

Tijeras vasculares

Ciseaux vasculaires

Forbici vascolari







finoLine

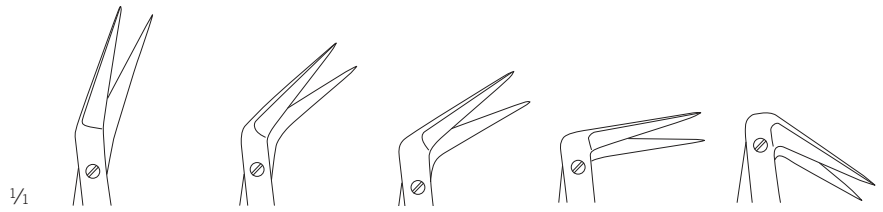

1/2

Dietrich fino
11-404-25-07 -
11-407-00-07



 highMed		25°	45°	60°	90°	125°
	 highMed^{wave}		25°	45°	60°	90°
18,5 cm / 7 2/8"		15 mm	15 mm	15 mm	15 mm	15 mm
		15 mm	15 mm	15 mm	15 mm	15 mm
		11-404-25-07	11-404-45-07	11-404-60-07	11-404-90-07	11-405-00-07
		11-406-25-07	11-406-45-07	11-406-60-07	11-406-90-07	11-407-00-07

Mikroscheren

Micro Scissors
Micro-Tijeras
Micro-Ciseaux
Micro-Forbici

Scheren

Scissors
Tijeras
Ciseaux
Forbici



11



1/2

11-402-25-07 -
11-411-00-09



		25°	45°	60°	90°	125°
18 cm / 7 1/8"		7 mm	7 mm	7 mm	7 mm	7 mm
	St	11-402-25-07	11-402-45-07	11-402-60-07	11-402-90-07	11-403-00-07
	Ti	11-410-25-09	11-410-45-09	11-410-60-09	11-410-90-09	11-411-00-09



1/2

11-384-25-07 -
11-409-00-09

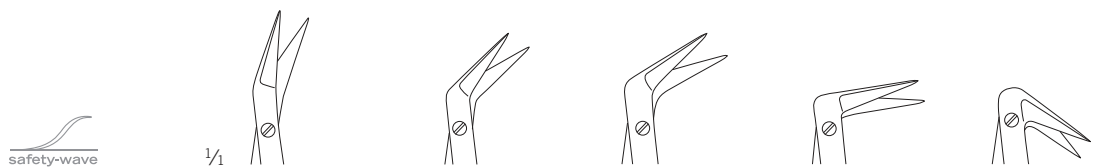

		25°	45°	60°	90°	125°
18 cm / 7 1/8"		10 mm	10 mm	10 mm	10 mm	10 mm
	St	11-400-25-07	11-400-45-07	11-400-60-07	11-400-90-07	11-401-00-07
	Ti	11-408-25-09	11-408-45-09	11-408-60-09	11-408-90-09	11-409-00-09
21 cm / 8 2/8"	St	11-384-25-07	11-384-45-07	11-384-60-07	11-384-90-07	11-385-00-07
23 cm / 9"	St	11-398-25-07	11-398-45-07	11-398-60-07	11-398-90-07	11-399-00-07

Mikroscheren

Micro Scissors

Micro-Tijeras

Micro-Ciseaux

Micro-Forbici



1/2

11-414-25-07 -
11-415-00-07



1/1



		25°	45°	60°	90°	125°
18 cm / 7 1/8"		7 mm	7 mm	7 mm	7 mm	7 mm
		11-414-25-07	11-414-45-07	11-414-60-07	11-414-90-07	11-415-00-07



1/2

11-412-25-07 -
11-439-00-07



1/1



		25°	45°	60°	90°	125°
18 cm / 7 1/8"		10 mm	10 mm	10 mm	10 mm	10 mm
		11-412-25-07	11-412-45-07	11-412-60-07	11-412-90-07	11-413-00-07
21 cm / 8 2/8"		11-436-25-07	11-436-45-07	11-436-60-07	11-436-90-07	11-437-00-07
23 cm / 9"		11-438-25-07	11-438-45-07	11-438-60-07	11-438-90-07	11-439-00-07

Mikroscheren

Micro Scissors
Micro-Tijeras
Micro-Ciseaux
Micro-Forbici

Scheren

Scissors
Tijeras
Ciseaux
Forbici



1/2

11-416-25-07 -
11-417-00-07

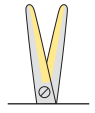

TC GOLD

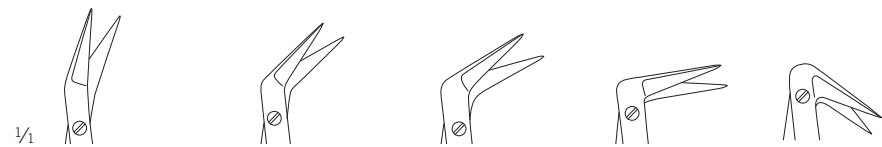

		25°	45°	60°	90°	125°
18 cm / 7 1/8"		10 mm	10 mm	10 mm	10 mm	10 mm
		11-416-25-07	11-416-45-07	11-416-60-07	11-416-90-07	11-417-00-07

für feine verkalkte GefäÙe
for delicate calcified vessels
para vasos finos calcificados
pour les vaisseaux calcifiés délicats
per vasi sottili calcificati



1/2

11-418-25-07 -
11-419-00-07

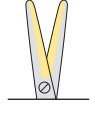

TC GOLD

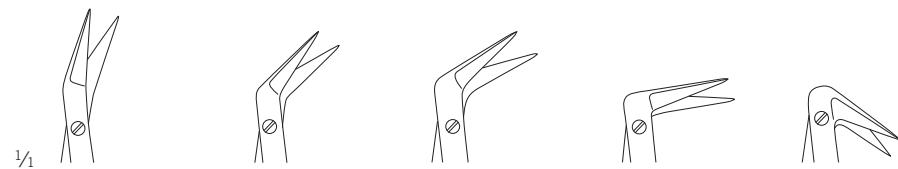

		25°	45°	60°	90°	125°
18 cm / 7 1/8"		10 mm	10 mm	10 mm	10 mm	10 mm
		11-418-25-07	11-418-45-07	11-418-60-07	11-418-90-07	11-419-00-07

für feine verkalkte GefäÙe
for delicate calcified vessels
para vasos finos calcificados
pour les vaisseaux calcifiés délicats
per vasi sottili calcificati

Gefäßscheren

Vascular Scissors

Tijeras vasculares

Ciseaux vasculaires

Forbici vascolari

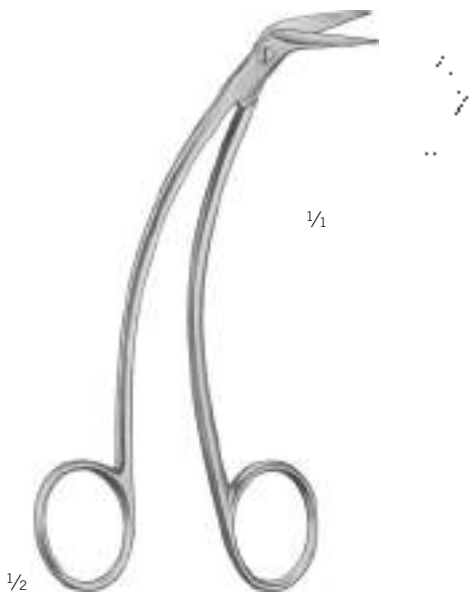

Favaloro
11-419-90-07
14,5 cm / 5 7/8"

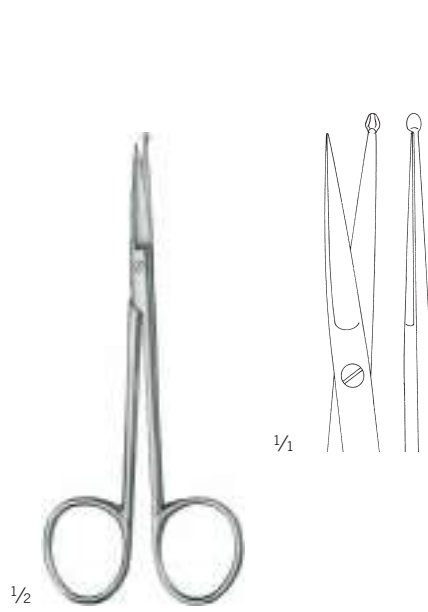

11-420-11-07
12 cm / 4 5/8"

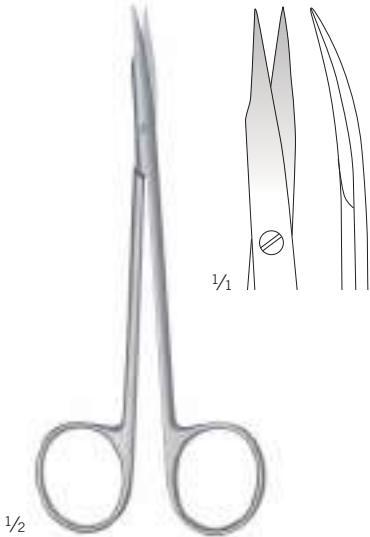

11-421-14-07
14 cm / 5 4/8"



11-422-15-07
14,5 cm / 5 7/8"

Koronarscheren

Coronary Scissors
Tijeras coronarias
Ciseaux coronaires
Forbici per arteria coronaria

Scheren



Scissors
Tijeras
Ciseaux
Forbici

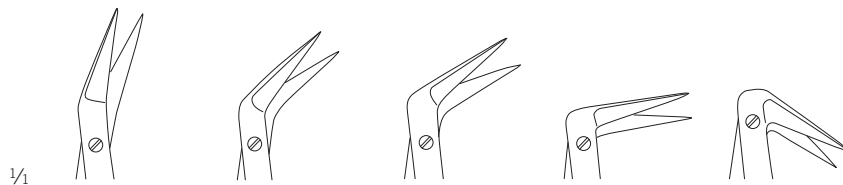

1/2

Dietrich
11-423-25-07 -
11-428-00-07





		25°	45°	60°	90°	125°
 highMed	18,5 cm / 7 2/8"	10 mm	10 mm	10 mm	10 mm	10 mm
	St	11-423-25-07	11-423-45-07	11-423-60-07	11-423-90-07	11-424-00-07
 highMed wave	18,5 cm / 7 2/8"	10 mm	10 mm	10 mm	10 mm	10 mm
	St	a11-425-25-07	11-425-45-07	11-425-60-07	11-425-90-07	11-426-00-07
 TC GOLD	18,5 cm / 7 2/8"	10 mm	10 mm	10 mm	10 mm	10 mm
	St	11-427-25-07	11-427-45-07	11-427-60-07	11-427-90-07	11-428-00-07

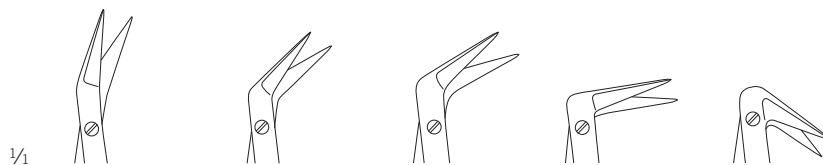

1/2

Mikro-Hegemann
11-429-25-07 -
11-432-00-07



		25°	45°	60°	90°	125°
 highMed	18,5 cm / 7 2/8"	7 mm	7 mm	7 mm	7 mm	7 mm
	St	11-429-25-07	11-429-45-07	11-429-60-07	11-429-90-07	11-430-00-07
 highMed wave	18,5 cm / 7 2/8"	7 mm	7 mm	7 mm	7 mm	7 mm
	St	11-431-25-07	11-431-45-07	11-431-60-07	11-431-90-07	11-432-00-07

Gefäßscheren

Vascular Scissors

Tijeras vasculares

Ciseaux vasculaires

Forbici vascolari



Favaloro
11-435-01-07
18 cm / 7 1/8"



Favaloro
11-435-02-07
18 cm / 7 1/8"



Strully
11-445-22-07 - 11-446-22-07
22 cm / 8 5/8"

Neurochirurgische Schere
Neurosurgical scissors
Tijeras para neurocirugía
Ciseaux pour neurochirurgie
Forbici per neurochirurgia



11-446-22-07

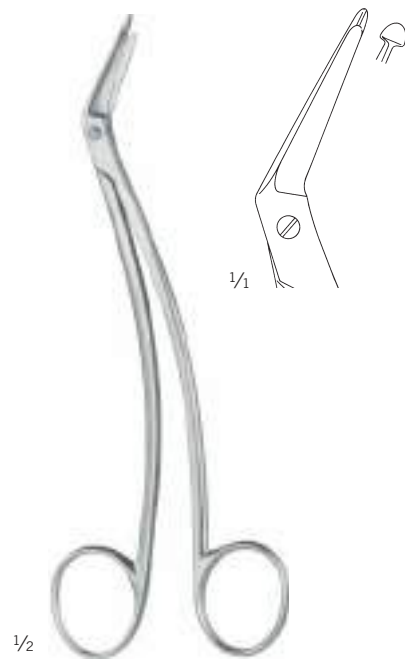

Schmieden-Taylor
11-455-17-07
16,5 cm / 6 4/8"

Duraschere
Dura scissors
Tijeras para duramadre
Ciseaux pour la dure-mère
Forbici per dura madre

Präparierscheren

Dissecting Scissors
Tijeras de disección
Ciseaux à dissection
Forbici per dissezione

Scheren

Scissors
Tijeras
Ciseaux
Forbici



Toennis-Adson
11-459-17-07
17,5 cm / 6 7/8"

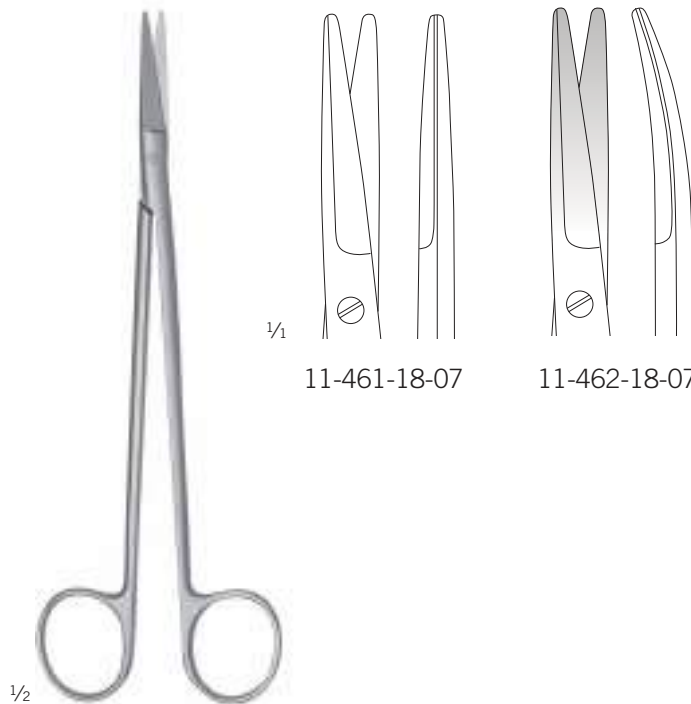

Toennis
11-461-18-07 -
11-462-18-07
18 cm / 7 1/8"

Präparierscheren

Dissecting Scissors
Tijeras de disección
Ciseaux à dissection
Forbici per dissezione

Arbeitslänge
working length
largo útil
longueur utile
lunghezza utile
120 mm

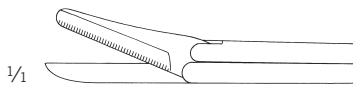

1/2

Olivecrona
11-475-23-07

Trigeminusschere
Trigeminal scissors
Tijeras para nervio trigémino
Ciseaux pour le nerf trigéminal
Forbici per il nervo trigemino
eine Schneide gezahnt
one toothed cutting edge
una hoja dentada
une lame dentelée
una lama dentata

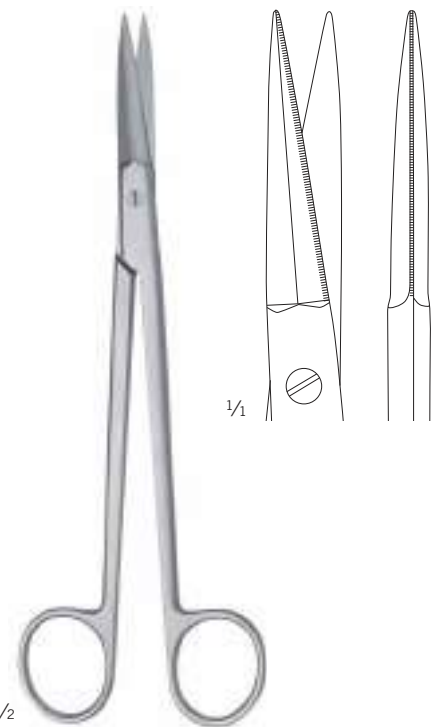

1/2

McIndoe
11-480-19-07

18,5 cm / 7 2/8"
eine Schneide gezahnt
one toothed cutting edge
una hoja dentada
une lame dentelée
una lama dentata

Tonsillenscheren

Tonsil Scissors
Tijeras para amígdalas
Ciseaux pour les amygdales
Forbici per tonsille

Scheren

Scissors
Tijeras
Ciseaux
Forbici



Dean
11-495-17-07
17,5 cm / 6 7/8"

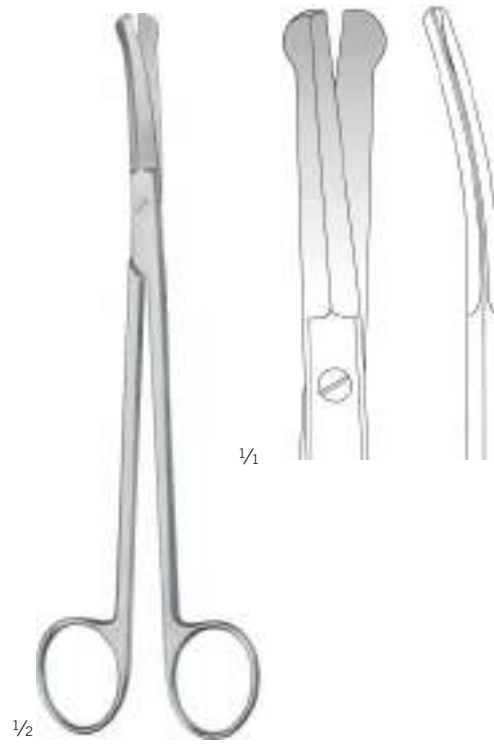

Good
11-499-19-07
19,5 cm / 7 5/8"

Tonsillenscheren

Tonsil Scissors

Tijeras para amígdalas

Ciseaux pour les amygdales

Forbici per tonsille



Dean	Standard	TCGOLD
17,5 cm / 6 7/8"	11-497-17-07	11-994-17-07

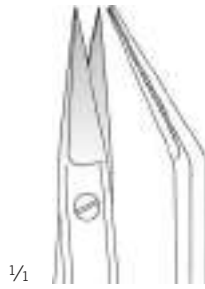

eine Schneide gezahnt
 one toothed cutting edge
 una hoja dentada
 une lame dentelée
 una lama dentata

Nasenscheren

Nasal Scissors
Tijeras nasales
Ciseaux nasaux
Forbici nasali

Scheren

Scissors
Tijeras
Ciseaux
Forbici

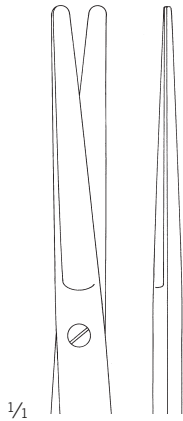

1/1

1/2

Fomon
11-503-15-07
14,5 cm / 5 7/8"



1/1

1/2

Cottle
11-505-16-07
16 cm / 6 2/8"

11

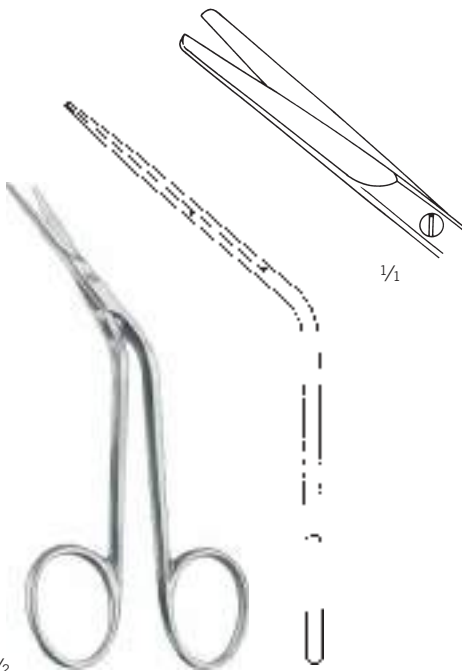

1/1

1/2

Fomon
11-507-15-07
14 cm / 5 4/8"

Nasenscheren

Nasal Scissors
Tijeras nasales
Ciseaux nasaux
Forbici nasali

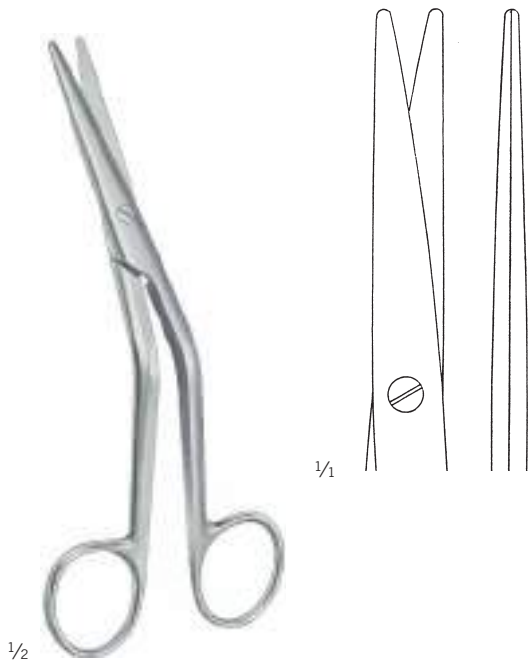

Cottle
11-509-16-07
15,5 cm / 6 1/8"



Heymann
11-511-18-07
18 cm / 7 1/8"

Arbeitslänge
working length
largo útil
longueur utile
lunghezza utile
85 mm



Heymann
11-513-18-07
18 cm / 7 1/8"
eine Schneide gezahnt
one toothed cutting edge
una hoja dentada
une lame dentelée
una lama dentata

Arbeitslänge
working length
largo útil
longueur utile
lunghezza utile
85 mm

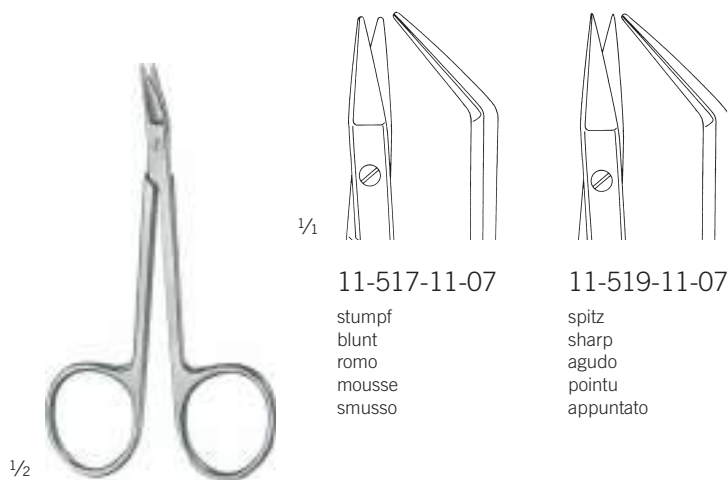

Converse
11-517-11-07 -
11-519-11-07
10,5 cm / 4 1/8"

11-517-11-07
stumpf
blunt
romo
mousse
smusso

11-519-11-07
spitz
sharp
agudo
pointu
appuntato

Episiotomiescheren

Episiotomy Scissors
Tijeras para episiotomía
Ciseaux à épisiotomie
Forbici per episiotomia

Scheren

Scissors
Tijeras
Ciseaux
Forbici

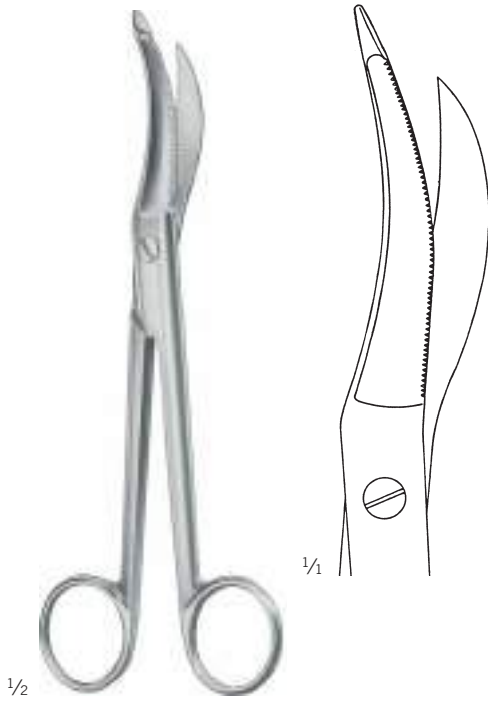

Waldmann
11-531-18-07

18 cm / 7 1/8"

eine Schneide gezahnt
one toothed cutting edge
una hoja dentada
une lame dentelée
una lama dentata



Braun-Stadler
11-535-14-07

14,5 cm / 5 6/8"

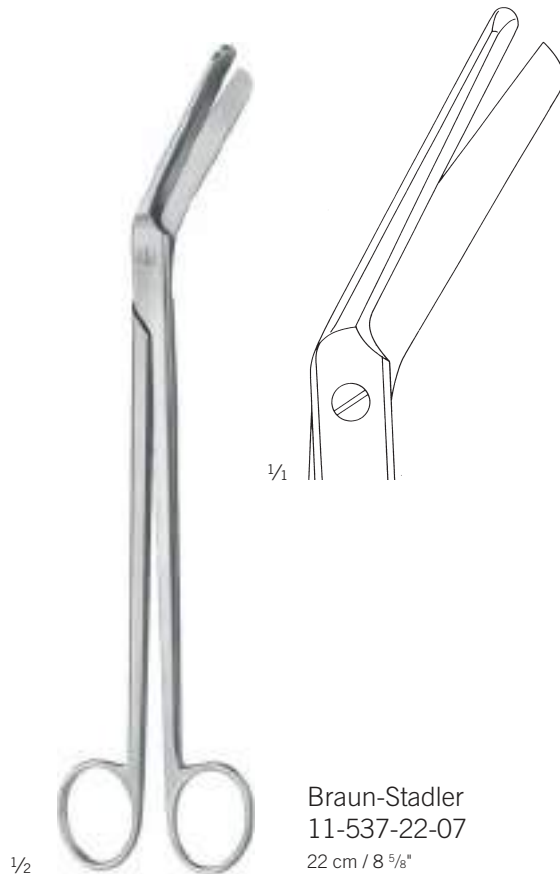

Braun-Stadler
11-537-22-07

22 cm / 8 5/8"

Nabelschnurscheren

Umbilical Scissors

Tijeras umbilicales

Ciseaux pour le cordon ombilical

Forbici ombelicali



Mod. USA
11-545-10-07
10,5 cm / 4 1/8"



Schuhmacher
11-547-16-07
15,5 cm / 6 1/8"



Busch
11-551-16-07
16 cm / 6 2/8"



Busch
11-553-16-07
16 cm / 6 2/8"
eine Schneide gezahnt
one toothed cutting edge
una hoja dentada
una lame dentelée
una lama dentata

Chirurgische Scheren, Zahnfleischscheren

Operating Scissors, Gum Scissors

Tijeras quirúrgicas, Tijeras para encías

Ciseaux chirurgicaux, Ciseaux à gencives

Forbici per chirurgia, Forbici per gengiva

Scheren

Scissors

Tijeras

Ciseaux

Forbici



Goldman-Fox	Standard	TCGOLD
13 cm / 5 1/8"	11-566-13-07	11-980-13-07

Standard	TCGOLD
11-567-13-07	11-981-13-07

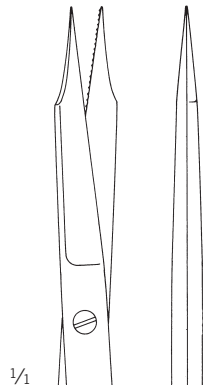

eine Schneide gezahnt
 one toothed cutting edge
 una hoja dentada
 une lame dentelée
 una lama dentata

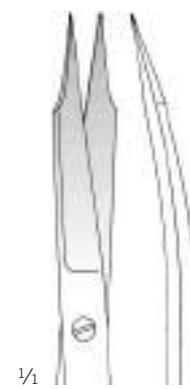

eine Schneide gezahnt
 one toothed cutting edge
 una hoja dentada
 une lame dentelée
 una lama dentata

Chirurgische Scheren, Zahnfleischscheren

Operating Scissors, Gum Scissors

Tijeras quirúrgicas, Tijeras para encías

Ciseaux chirurgicaux, Ciseaux à gencives

Forbici per chirurgia, Forbici per gengiva



1/2

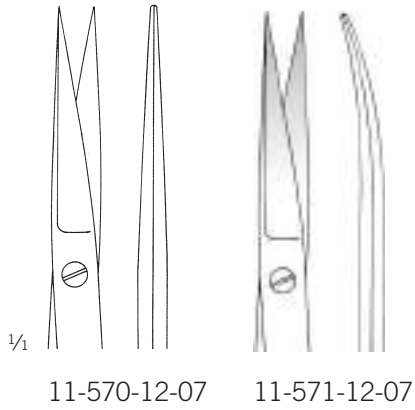

11-570-12-07

11-571-12-07

Wagner
11-570-12-07 -
11-571-12-07
12 cm / 4 6/8"

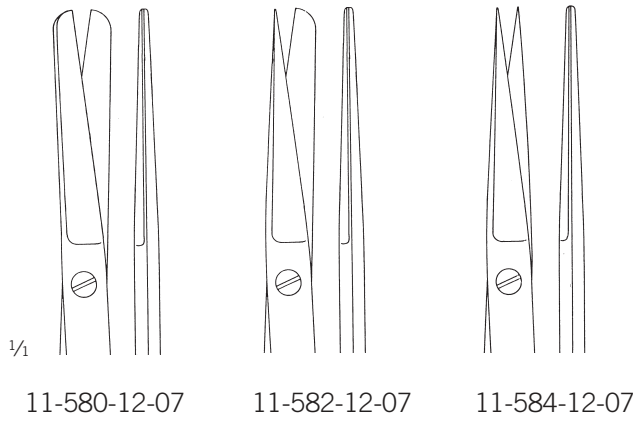

11-580-12-07

11-582-12-07

11-584-12-07



1/2

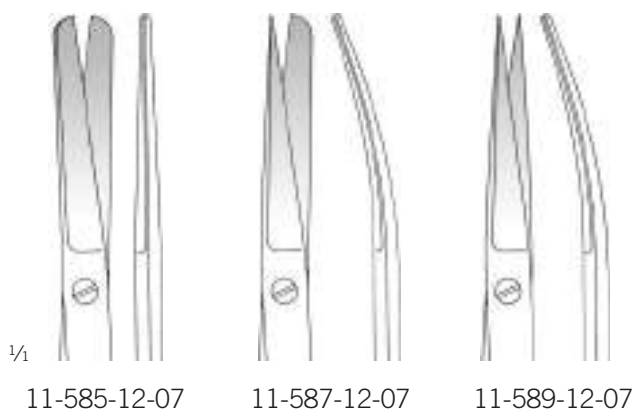

11-585-12-07

11-587-12-07

11-589-12-07

11-580-12-07 -
11-589-12-07
12 cm / 4 6/8"

Chirurgische Scheren, Zahnfleischscheren

Operating Scissors, Gum Scissors

Tijeras quirúrgicas, Tijeras para encías

Ciseaux chirurgicaux, Ciseaux à gencives

Forbici per chirurgia, Forbici per gengiva

Scheren

Scissors

Tijeras

Ciseaux

Forbici



La Grange
11-593-11-07

11,5 cm / 4 4/8"

S-Form, eine Schneide gezahnt
S-shape, one toothed cutting edge
forma S, una hoja dentada
courbé en S, une lame dentelée
curvo in forma S, una lama de

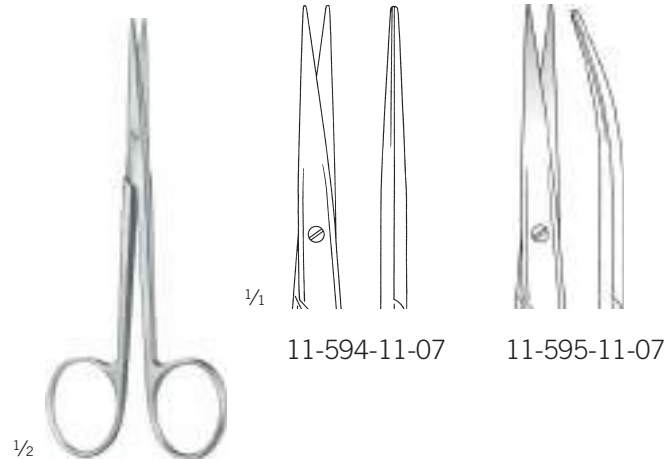

11-594-11-07 -
11-595-11-07

11,5 cm / 4 4/8"

fein
delicate
fino
fin
fino

Zahnfleischscheren

Gum Scissors

Tijeras para encías

Ciseaux à gencives

Forbici per gengiva



	Standard	TCGOLD
16 cm / 6 2/8"	11-605-16-07	11-999-16-07

	Standard	TCGOLD
	11-607-16-07	11-997-16-07

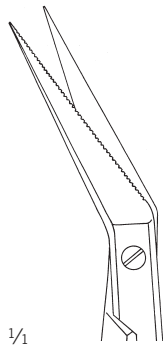

1/1

eine Schneide gezahnt
one toothed cutting edge
una hoja dentada
une lame dentelée
una lama dentata

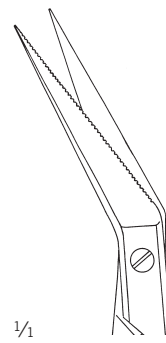

1/1

eine Schneide gezahnt
one toothed cutting edge
una hoja dentada
une lame dentelée
una lama dentata

Irisscheren

Iris Scissors
Tijeras para iridectomía
Ciseaux à iridectomie
Forbici per iridectomia

Scheren

Scissors
Tijeras
Ciseaux
Forbici



11-618-08-07 -
11-619-08-07
9 cm / 3 4/8"
sehr fein
very delicate
muy fino
très fin
strafino

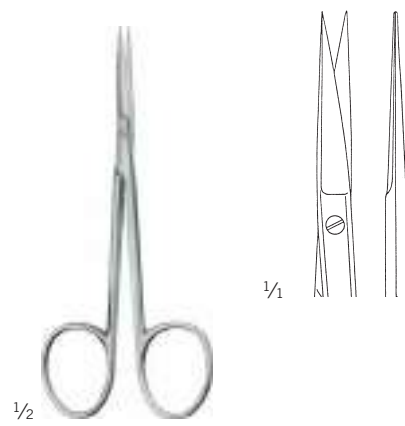

11-622-10-07
10,5 cm / 4 1/8"
extra flache Blätter
extra flat blades
hojas muy delgadas
lames extrêmement plates
con lame molto piate

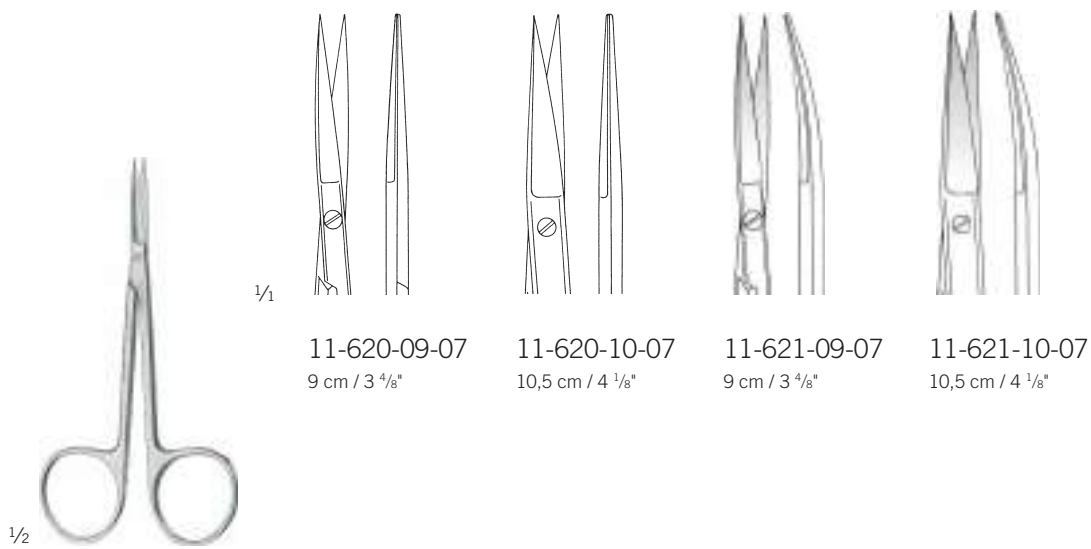

11-620-09-07 -
11-621-10-07

Irisscheren
 Iris Scissors
 Tijeras para iridectomía
 Ciseaux à iridectomie
 Forbici per iridectomia

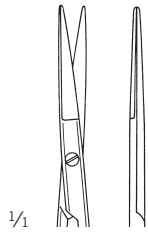

11-624-09-07



11-625-09-07

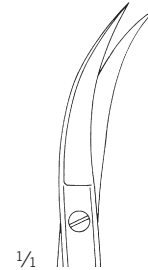

11-633-11-07
 11,5 cm / 4 1/8"

Mod. Bonn
 11-624-09-07 -
 11-625-09-07
 9 cm / 3 1/8"

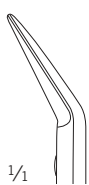
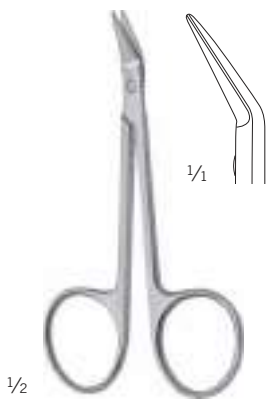

Graefe
 11-637-10-07
 10 cm / 3 7/8"

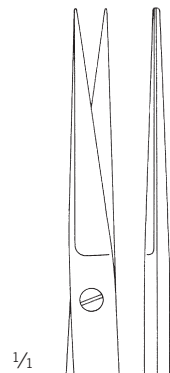

11-640-12-07



11-641-12-07

11-640-12-07 -
 11-641-12-07
 12,5 cm / 4 7/8"

Irisscheren

Iris Scissors

Tijeras para iridectomía

Ciseaux à iridectomie

Forbici per iridectomia

Scheren

Scissors

Tijeras

Ciseaux

Forbici



	Standard	TCGOLD	SuperCut
11,5 cm / 4 5/8"	11-630-11-07	11-982-11-07	11-672-11-07

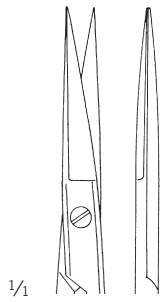

Irisscheren
 Iris Scissors
 Tijeras para iridectomía
 Ciseaux à iridectomie
 Forbici per iridectomia

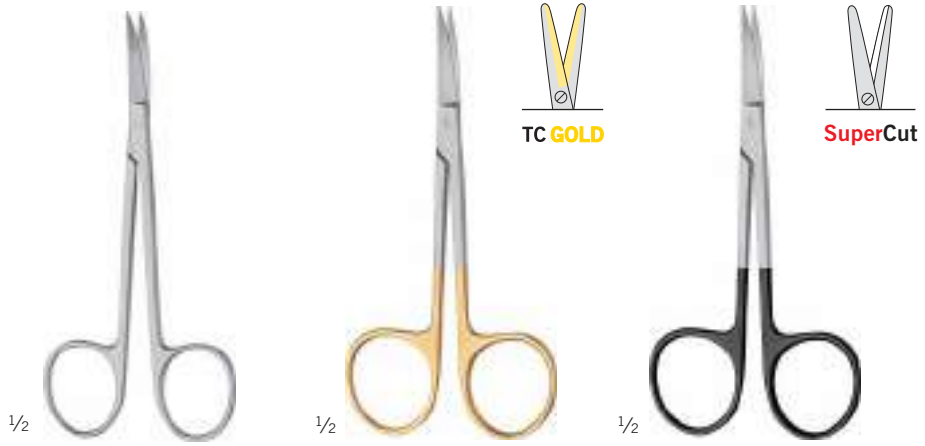

	Standard	TCGOLD	SuperCut
11,5 cm / 4 5/8"	11-631-11-07	11-983-11-07	11-673-11-07



Irisscheren

Iris Scissors

Tijeras para iridectomía

Ciseaux à iridectomie

Forbici per iridectomia

Scheren

Scissors

Tijeras

Ciseaux

Forbici



1/2



1/2

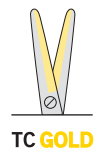

	Standard	TCGOLD
11,5 cm / 4 5/8"	11-635-11-07	11-989-11-07

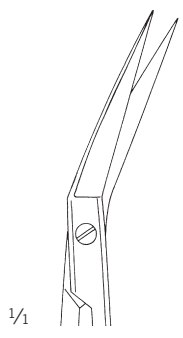

1/1

Irisscheren
 Iris Scissors
 Tijeras para iridectomía
 Ciseaux à iridectomie
 Forbici per iridectomia



Stevens	Standard	SuperCut
11 cm / 4 3/8"	11-680-11-07	11-674-10-07

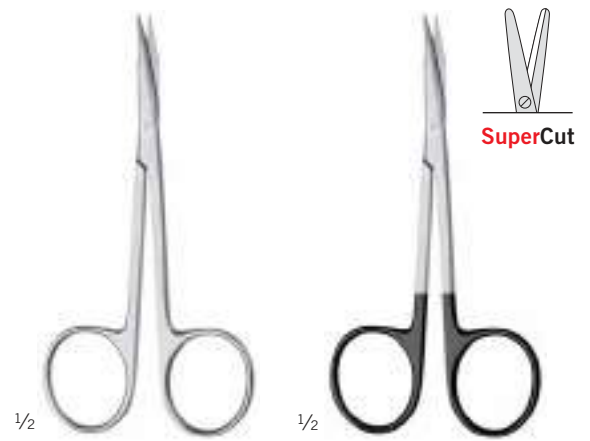

Standard	SuperCut
11-681-11-07	11-675-10-07

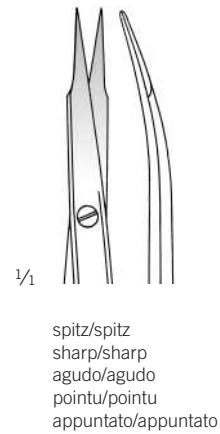
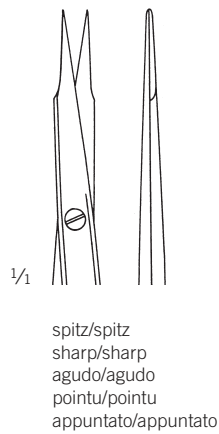

Irisscheren

Iris Scissors
Tijeras para iridectomía
Ciseaux à iridectomie
Forbici per iridectomia

Scheren

Scissors
Tijeras
Ciseaux
Forbici



Stevens	Standard	SuperCut
11 cm / 4 3/8"	11-682-11-07	11-676-10-07

Standard	SuperCut
11-683-11-07	11-677-10-07

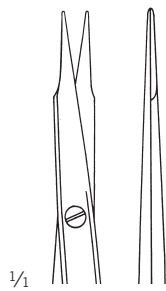

stumpf/stumpf
blunt/blunt
romo/romo
mousse/mousse
smusso/smusso



stumpf/stumpf
blunt/blunt
romo/romo
mousse/mousse
smusso/smusso

Strabismusscheren

Strabismus Scissors
Tijeras para estrabismo
Ciseaux à strabisme
Forbici per strabismo



11-690-11-07 -
11-691-11-07
11,5 cm / 4 4/8"

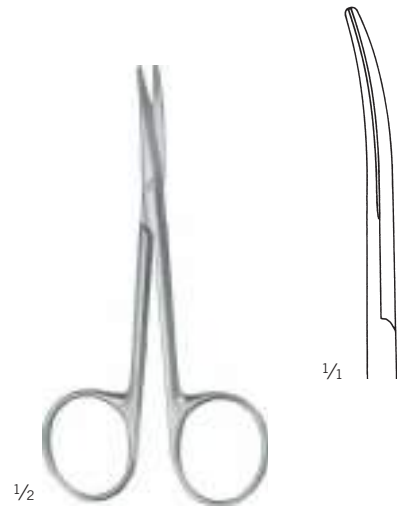

11-705-11-07
11,5 cm / 4 4/8"
Enukleationsschere
Enucleation Scissors
Tijera para enucleación
Ciseaux à énucléation
Forbici per enucleazione

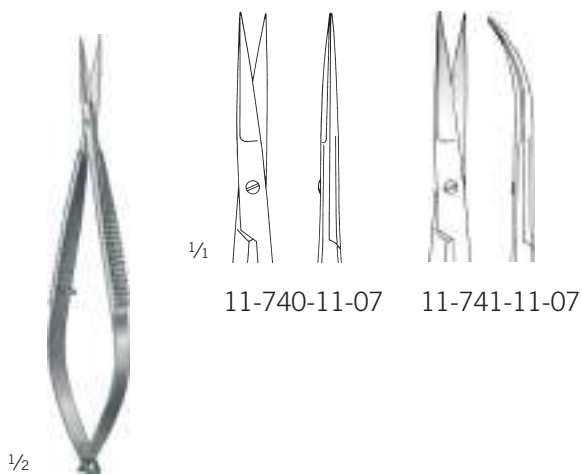

Westcott
11-740-11-07 -
11-741-11-07
11,5 cm / 4 4/8"

Mikroscheren

Micro Scissors
Micro-Tijeras
Micro-Ciseaux
Micro-Forbici

Scheren

Scissors
Tijeras
Ciseaux
Forbici



1/1

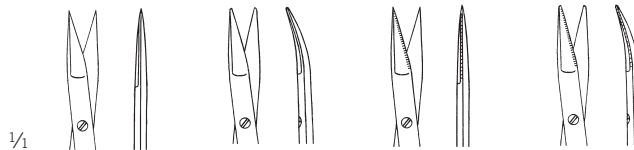

	A	D	A-SB	D-SB
	9 mm	9 mm	9 mm	9 mm
15 cm / 5 7/8"	11-700-00-07	11-701-00-07	11-700-01-07	11-701-01-07



1/1

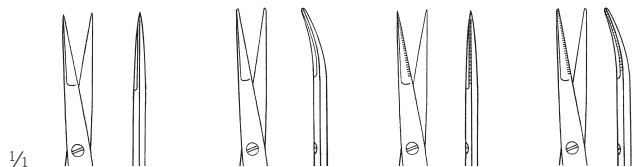

	A	D	A-SB	D-SB
	14 mm	14 mm	14 mm	14 mm
15 cm / 5 7/8"	11-700-04-07	11-701-04-07	11-700-05-07	11-701-05-07

1/2

11-700-00-07 -
11-701-05-07



1/1

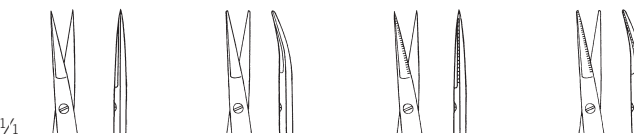

	A	D	A-SB	D-SB
	9 mm	9 mm	9 mm	9 mm
15 cm / 5 7/8"	11-700-02-07	11-701-02-07	11-700-03-07	11-701-03-07



1/1

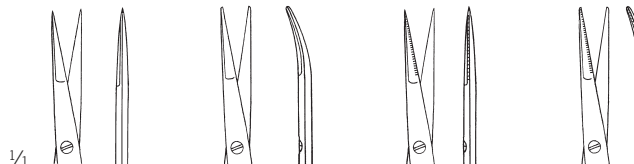

	A	D	A-SB	D-SB
	14 mm	14 mm	14 mm	14 mm
15 cm / 5 7/8"	11-700-06-07	11-701-06-07	11-700-07-07	11-701-07-07

1/2

11-700-02-07 -
11-701-07-07

Mikroscheren

Micro Scissors

Micro-Tijeras

Micro-Ciseaux

Micro-Forbici



1/1

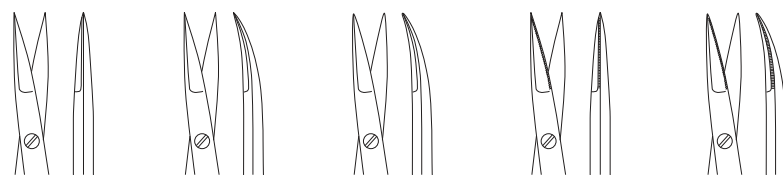

		A	A	D	A-SB	D-SB
15 cm / 5 7/8"		10 mm	10 mm	10 mm	10 mm	10 mm
		11-710-15-07	11-711-15-07			
		11-716-15-09	11-717-15-09			
18 cm / 7 1/8"		11-710-18-07	11-711-18-07	11-711-19-07	11-710-19-07	11-711-20-07
		11-716-18-09	11-717-18-09			
21 cm / 8 2/8"		11-710-21-07	11-711-21-07			
		11-716-21-09	11-717-21-09			
23 cm / 9"		11-710-23-07	11-711-23-07			

1/2

11-710-15-07 -
11-717-18-09

A = Adventitia
D = Präparation

A-SB = Adventitia, ein gezahntes Blatt
D-SB = Präparation, ein gezahntes Blatt

A = Adventitia
D = Dissection

A-SB = Adventitia, one serrated blade
D-SB = Dissection, one serrated blade

A = Adventicia
D = Disección

A-SB = Adventicia, una hoja dentada
D-SB = Disección, una hoja dentada

A = Advantice
D = Dissection

A-SB = Advantice, une lame dentelée
D-SB = Dissection, une lame dentelée

A = Avventizia
D = Dissezione

A-SB = Avventizia, una lama dentata
D-SB = Dissezione, una lama dentata

Mikroscheren

Micro Scissors
Micro-Tijeras
Micro-Ciseaux
Micro-Forbici

Scheren

Scissors
Tijeras
Ciseaux
Forbici

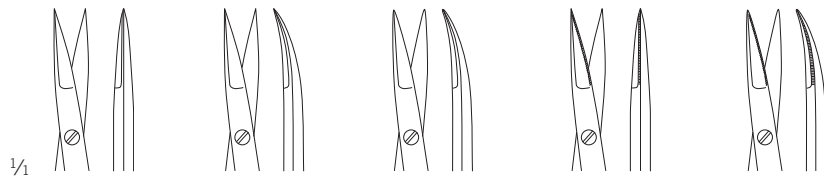

		A	A	D	A-SB	D-SB
15 cm / 5 7/8"		10 mm	10 mm	10 mm	10 mm	10 mm
	St	11-712-15-07	11-713-15-07			
	Ti	11-718-15-09	11-719-15-09			
18 cm / 7 1/8"	St	11-712-18-07	11-713-18-07	11-713-19-07	11-712-19-07	11-713-20-07
	Ti	11-718-18-09	11-719-18-09			
21 cm / 8 2/8"	St	11-712-21-07	11-713-21-07			
	Ti	11-718-21-09	11-719-21-09			
23 cm / 9 1/8"	St	11-712-23-07	11-713-23-07			

1/2

11-712-15-07 -
11-719-18-09

A = Adventitia
D = Präparation

A-SB = Adventitia, ein gezahntes Blatt
D-SB = Präparation, ein gezahntes Blatt

A = Adventitia
D = Dissection

A-SB = Adventitia, one serrated blade
D-SB = Dissection, one serrated blade

A = Adventicia
D = Disección

A-SB = Adventicia, una hoja dentada
D-SB = Disección, una hoja dentada

A = Advantice
D = Dissection

A-SB = Advantice, une lame dentelée
D-SB = Dissection, une lame dentelée

A = Avventizia
D = Dissezione

A-SB = Avventizia, una lama dentata
D-SB = Dissezione, una lama dentata

Mikroscheren

Micro Scissors

Micro-Tijeras

Micro-Ciseaux

Micro-Forbici

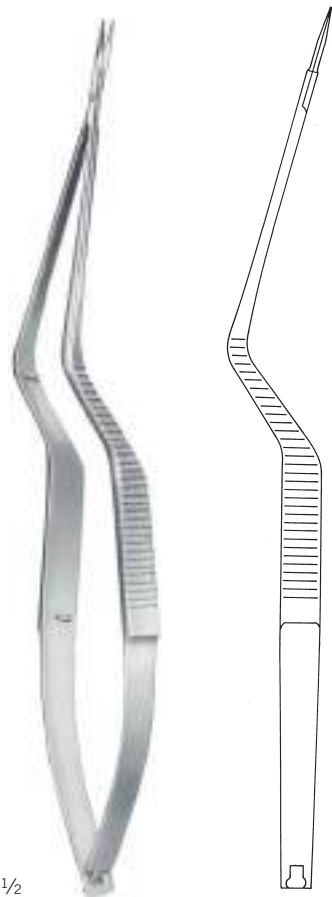

1/2

Jacobson
11-732-23-07 -
11-735-23-07

1/1



11-732-23-07
20,5 cm / 8 1/8"



11-733-23-07
20 cm / 7 7/8"

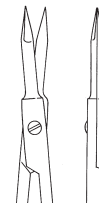

11-734-23-07
20,5 cm / 8 1/8"



11-735-23-07
20 cm / 7 7/8"

Mikroscheren

Micro Scissors
Micro-Tijeras
Micro-Ciseaux
Micro-Forbici

Scheren

Scissors
Tijeras
Ciseaux
Forbici



1/2

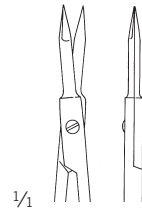

1/1

11-748-19-07
20 cm / 7 7/8"



11-749-19-07
18 cm / 7 1/8"

11-748-19-07 -
11-749-19-07

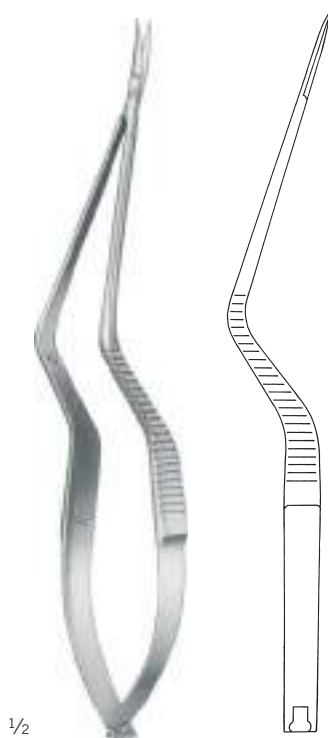

1/2



1/1

11-750-19-07
19 cm / 7 4/8"



11-751-19-07
18,5 cm / 7 2/8"
aufwärts gebogen
bent upwards
angulado hacia arriba
courbée en haut
angolato in alto



11-752-19-07
18,5 cm / 7 2/8"
abwärts gebogen
bent downwards
angulado hacia abajo
coudé en bas
angolato in basso

11-750-19-07 -
11-752-19-07

Mikroscheren, Mikro-Präparierscheren

Micro Scissors, Micro Dissecting Scissors

Micro-Tijeras, Micro-Tijeras de disección

Micro-Ciseaux, Micro-Ciseaux à dissection

Micro-Forbici, Micro-Forbici per dissezione

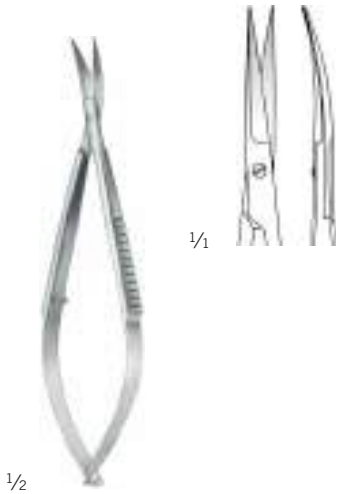

11-755-11-07
12 cm / 4 5/8"

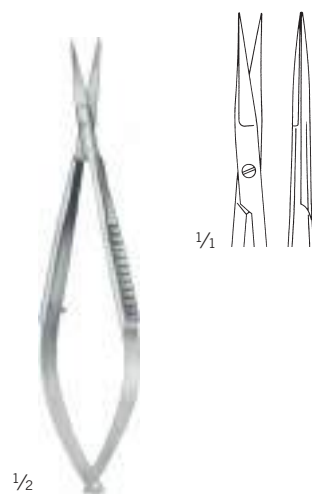

11-756-12-07
12 cm / 4 5/8"

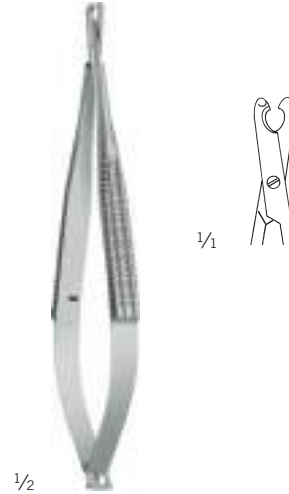

Biemer
11-758-12-07
12 cm / 4 5/8"

Mikro-Venenschere
Micro scissors for veins
Tijeras de micro para venas
Micro-ciseaux pour les veines
Forbici micro per vene

Zum Auffrischen von Gefäßstümpfen. Kein Abgleiten des Gefäßes und glatte, saubere Durchtrennung

For roughening vessel ends, vessel cannot slip off, clean, smooth cut

Renovación de extremos vasculares. Ningún resbalamiento del vaso, cortes limpios y lisos

Pour rafraîchir des moignons vasculaires. Les vaisseau ne peut pas glisser, coupe lisse et propre

Per cruentare le estremità vasili. Senza scivolamento del vaso, con distacco preciso

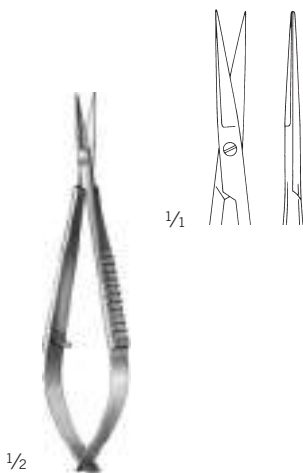

11-760-09-07
10 cm / 3 7/8"

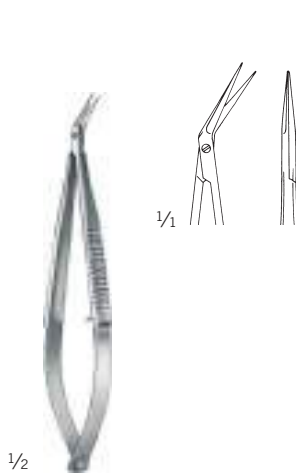

11-761-09-07
9,5 cm / 3 5/8"

Mikroscheren

Micro Scissors
Micro-Tijeras
Micro-Ciseaux
Micro-Forbici

Scheren

Scissors
Tijeras
Ciseaux
Forbici



11



JABOMA
11-765-18-07

18 cm / 7 1/8"

für Lippen-, Kiefer-, Gaumenspalte
for Cleft Palate
para fisura paladar
pour fente du palais
per cheilo-labbro-palato schisi



JABOMA
11-767-18-07

18 cm / 7 1/8"

für Lippen-, Kiefer-, Gaumenspalte
for Cleft Palate
para fisura paladar
pour fente du palais
per cheilo-labbro-palato schisi

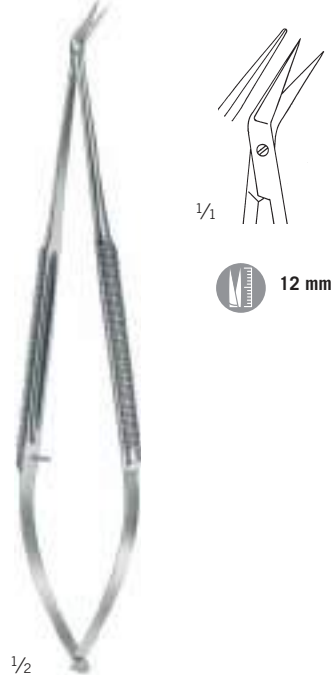

JABOMA
11-769-18-07

18 cm / 7 1/8"

für Lippen-, Kiefer-, Gaumenspalte
for Cleft Palate
para fisura paladar
pour fente du palais
per cheilo-labbro-palato schisi



11-776-02-07

19 cm / 7 4/8"

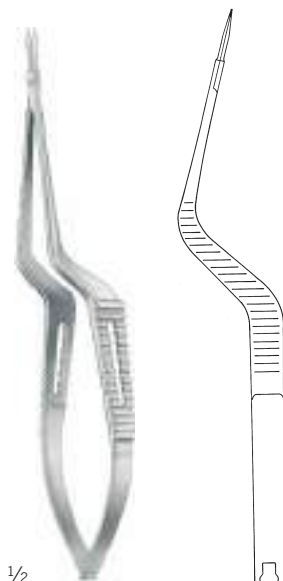

1/2

11-778-01-07 -
11-778-02-07

15,5 cm / 6 1/8"

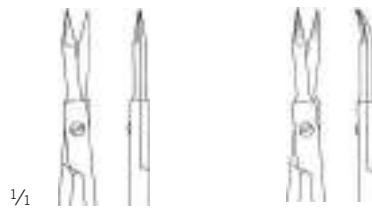

1/1

11-778-01-07

11-778-02-07

Darmscheren

Enterotomy Scissors

Tijeras para intestino

Ciseaux-entérotomes

Forbici per enterotomia

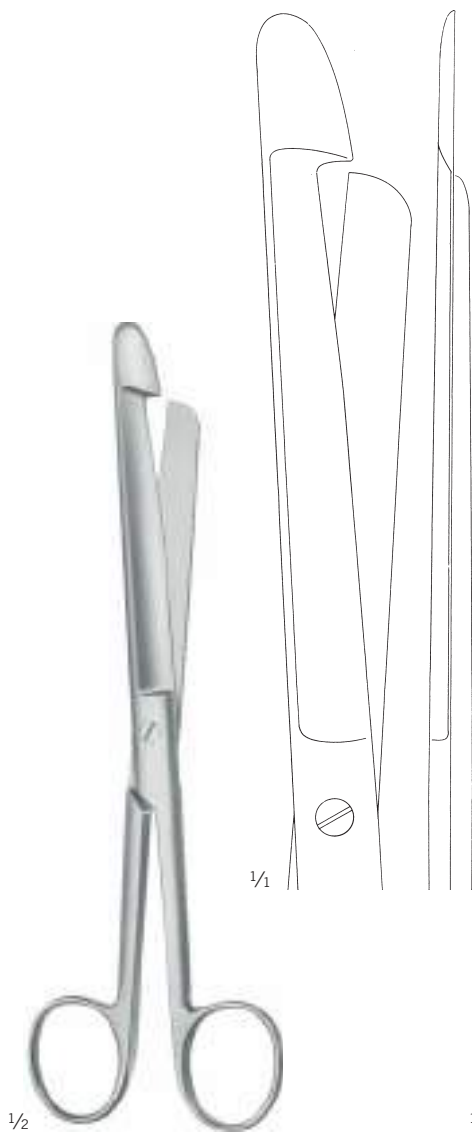

11-782-21-07
21,5 cm / 8 4/8"

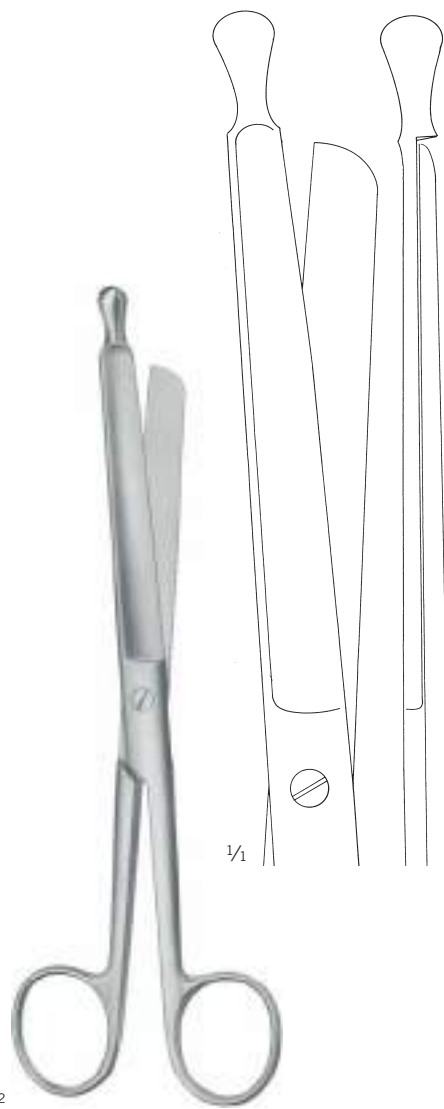

11-784-21-07
21,5 cm / 8 4/8"

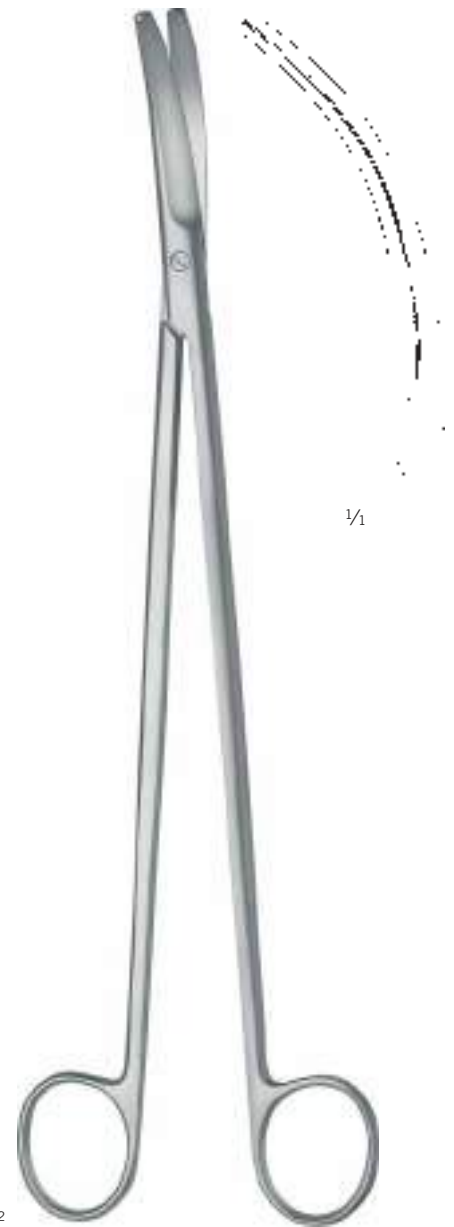

11-785-32-07
32,5 cm / 12 6/8"
Rektumschere
Rectal Scissors
Tijera para recto
Ciseaux pour rectum
Forbici per il retto

Präparierscheren, Face-lift-Scheren, Fadenscheren

Dissecting Scissors, Face-lift Scissors, Stitch Scissors

Tijeras de disección, Tijeras para Face-Lift, Tijeras para hilos

Ciseaux à dissection, Ciseaux pour Face-lift, Ciseaux à ligatures

Forbici per dissezione, Forbici per Face-lift, Forbici per legature

Scheren

Scissors

Tijeras

Ciseaux

Forbici

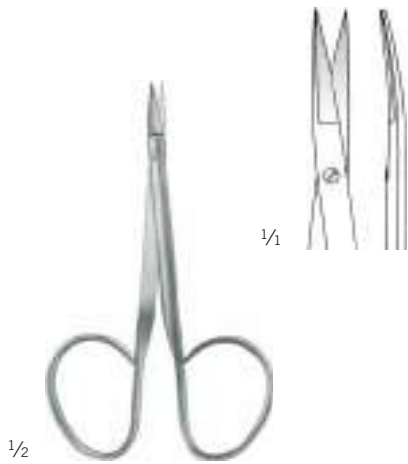

Salyer
11-784-09-07
9,5 cm / 3 5/8"

für Lippen-, Kiefer-, Gaumenspalte
for Cleft Palate
para fisura paladar
pour fente du palais
per cheilo-labbro-palato schisi

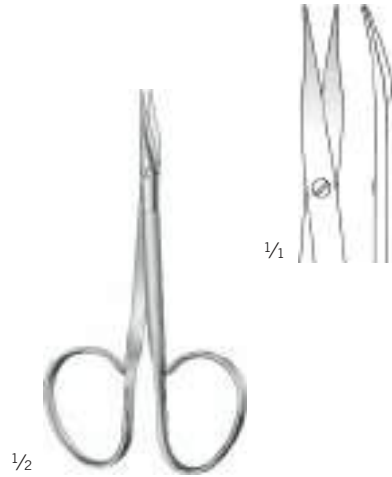

Salyer
11-801-10-07
10 cm / 3 7/8"

für Lippen-, Kiefer-, Gaumenspalte
for Cleft Palate
para fisura paladar
pour fente du palais
per cheilo-labbro-palato schisi

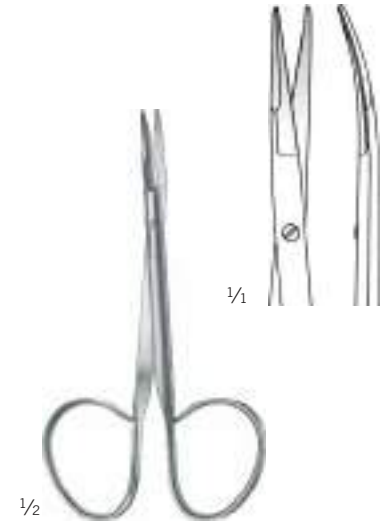

Kaye
11-809-11-07
11 cm / 4 3/8"

beide Schneiden gezahnt
both cutting edges serrated
ambos filos dentados
deux lames dentées
entrambe le lame dentate



Northbent
11-819-13-07
13 cm / 5 1/8"

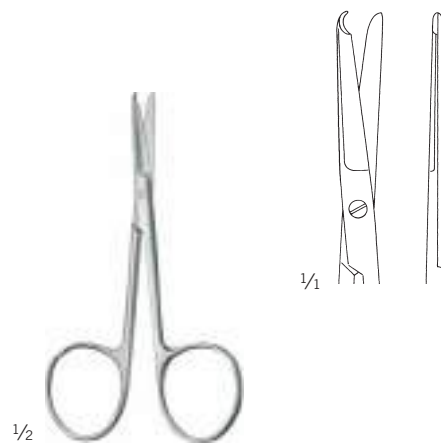

Spencer
11-824-09-07
9 cm / 3 4/8"

Fadenscheren

Stitch Scissors

Tijeras para hilos

Ciseaux à ligatures

Forbici per legature

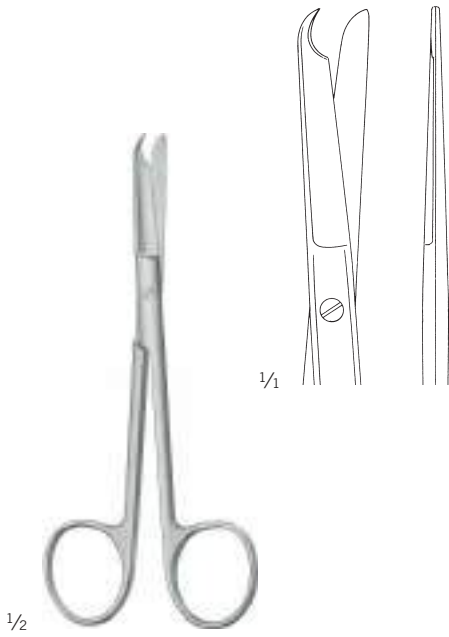

Spencer
11-826-13-07
13 cm / 5 1/8"



Buck
11-830-14-07 -
11-830-18-07

11-830-14-07
14,5 cm / 5 6/8"

11-830-18-07
18 cm / 7 1/8"

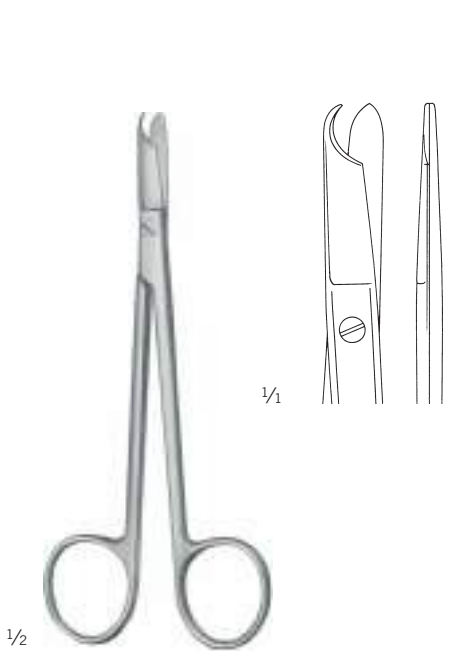

Littauer
11-834-14-07
14 cm / 5 4/8"

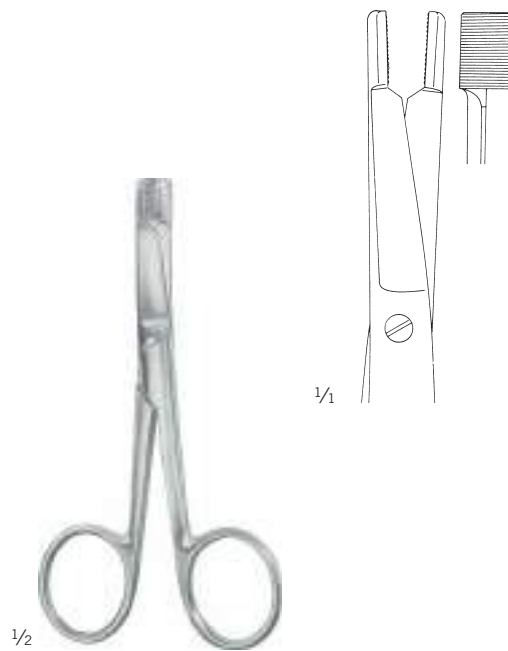

Eiselsberg
11-840-12-07
12 cm / 4 6/8"

Drahtscheren

Wire Cutting Scissors
Tijeras para cortar hilos de acero
Ciseaux coupe-fil
Forbici per tagliare fili metallici

Scheren

Scissors
Tijeras
Ciseaux
Forbici



1/2
Universal
11-865-12-07



1/2
Universal
11-995-12-07

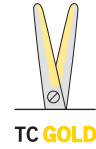

	Standard	TCGOLD
12 cm / 4 7/8"	11-865-12-07	11-995-12-07
	max Ø = 0,4 mm weicher Draht soft wire alambre blando fil métallique souple filo morbido	max Ø = 1,0 mm max Ø = 0,5 mm weicher Draht harter Draht soft wire hard wire alambre blando alambre duro fil métallique souple fil métallique raide filo morbido filo rigido

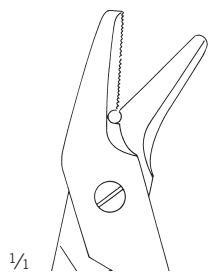

1/1
eine Schneide gezahnt
one toothed cutting edge
una hoja dentada
une lame dentelée
una lama dentata

Drahtscheren

Wire Cutting Scissors

Tijeras para cortar hilos de acero

Ciseaux coupe-fil

Forbici per tagliare fili metallici



1/2

Beebee

11-874-10-07 -

11-879-12-07

1/4



11-874-10-07
10 cm / 3 7/8"

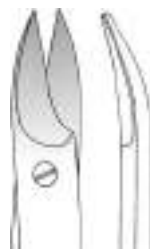

11-875-10-07
10 cm / 3 7/8"

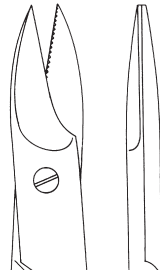

11-878-12-07
12 cm / 4 6/8"

eine Schneide gezahnt
one toothed cutting edge
una hoja dentada
une lame dentelée
una lama dentata



11-879-12-07
12 cm / 4 6/8"

eine Schneide gezahnt
one toothed cutting edge
una hoja dentada
une lame dentelée
una lama dentata

highMed-Präparierscheren

Dissecting Scissors
Tijeras de disección
Ciseaux à dissection
Forbici per dissezione

Scheren

Scissors
Tijeras
Ciseaux
Forbici



highMed

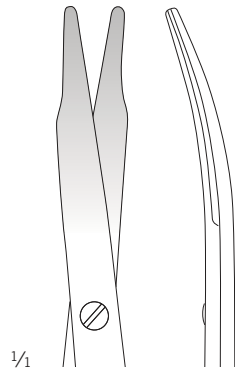

1/1

1/2



Lillehei-Potts
11-882-18-07
18 cm / 7 1/8"



highMed

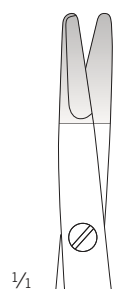

1/1



11-886-20-07
20°

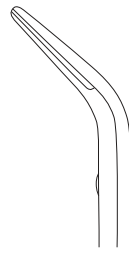

11-886-50-07
50°

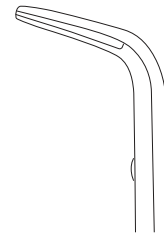

11-886-90-07
90°

1/2



Potts-De Martell
11-886-20-07 -
11-886-90-07
18 cm / 7 1/8"

11

Ligaturscheren

Ligature Scissors

Tijeras para ligaduras

Ciseaux pour ligatures

Forbici per legature

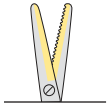

suture Cut
TC GOLD

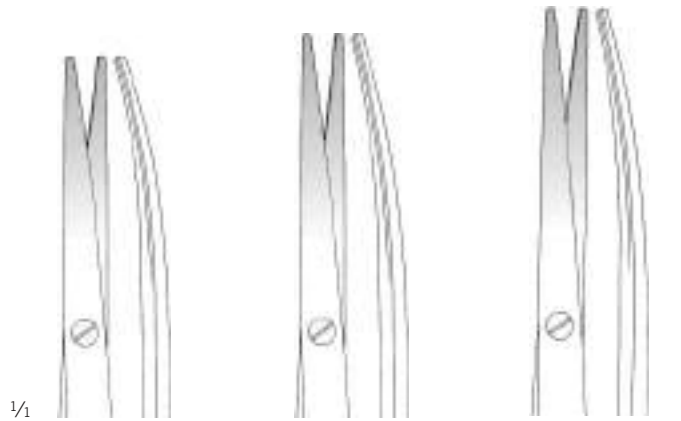

11-914-11-07
11,5 cm / 4 5/8"

11-914-14-07
14,5 cm / 5 3/4"

11-914-18-07
18 cm / 7"



1/2

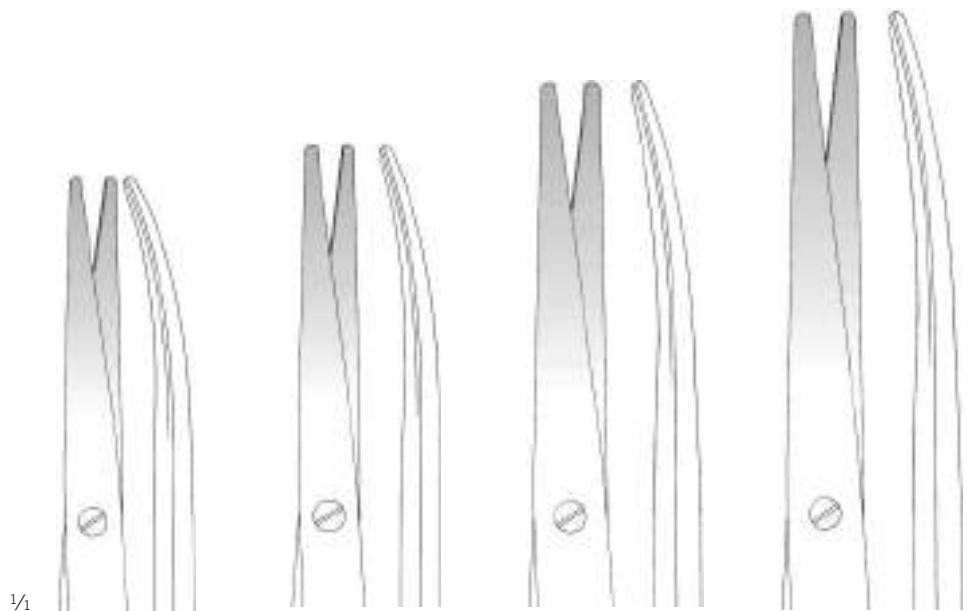

11-914-20-07
20,5 cm / 8"

11-914-23-07
23 cm / 9"

11-914-25-07
25 cm / 9 3/4"

11-914-30-07
30 cm / 11 5/8"

11-914-11-07 -
11-914-30-07

für Synthetik-Nahtmaterial,
eine Schneide gezahnt

for synthetic suture material,
one toothed cutting edge

para hilos de sutura sintéticos,
una hoja dentada

pour matériel de suture synthétique,
une lame dentelée

per materiale di sutura sintetico,
una lama dentata

Ligaturscheren

Ligature Scissors

Tijeras para ligaduras

Ciseaux pour ligatures

Forbici per legature

Scheren

Scissors

Tijeras

Ciseaux

Forbici

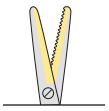

sutureCut

TC GOLD

11



1/2

1/1

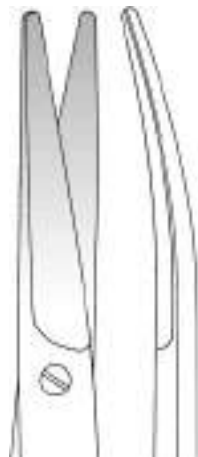

11-915-14-07
14,5 cm / 5 3/4"

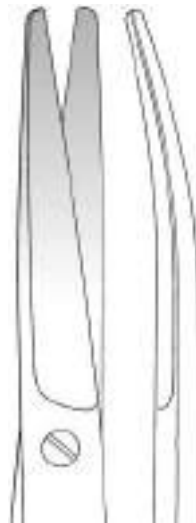

11-915-17-07
17 cm / 6 3/4"

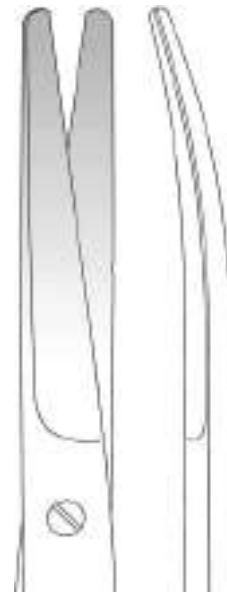

11-915-23-07
23 cm / 9"

11-915-14-07 -
11-915-23-07

für Synthetik-Nahtmaterial,
eine Schneide gezahnt

for synthetic suture material,
one toothed cutting edge

para hilos de sutura sintéticos,
una hoja dentada

pour matériel de suture synthétique,
une lame dentelée

per materiale di sutura sintetico,
una lama dentata

TCC-BlackLine-Scheren

TCC-BlackLine Scissors

Tijeras TCC-BlackLine

Ciseaux TCC-BlackLine

Forbici TCC-BlackLine



TCC BlackLine

finoLine TC GOLD



Tönnis-Adson TCC-BlackLine

11-919-14-07 -

11-919-18-07

sehr fein
very delicate
muy fino
très fin
strafino

Keramik-Beschichtung,
eine Schneide gezahnt

Coated with ceramics,
one toothed cutting edge

Cubierto con material de cerámicas,
una hoja dentada

Recouvert avec matériau de la
céramique, une lame dentelée

Ricoprito con materiale di ceramica,
una lama dentata

Präparierscheren, Chirurgische Scheren

Dissecting Scissors, Operating Scissors
 Tijeras de disección, Tijeras quirúrgicas
 Ciseaux à dissection, Ciseaux chirurgicaux
 Forbici per dissezione, Forbici per chirurgia

Scheren

Scissors
 Tijeras
 Ciseaux
 Forbici

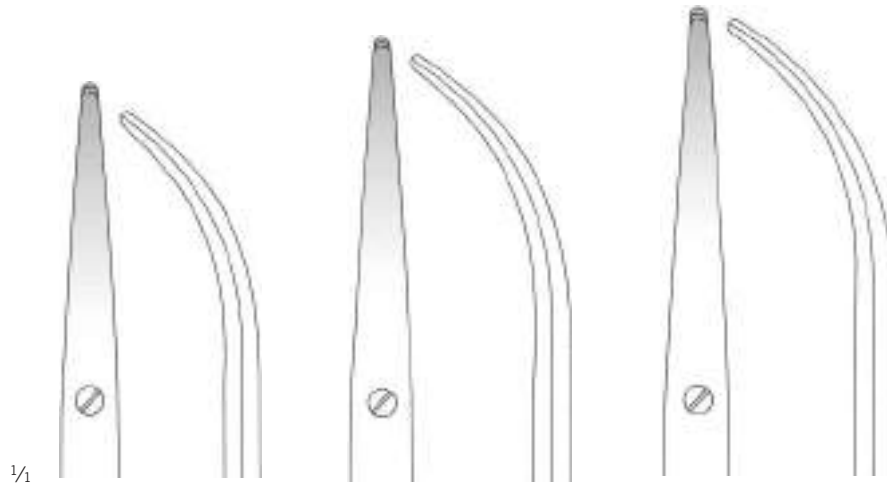

1/1

11-945-20-07
 20 cm / 7 7/8"

11-945-23-07
 23 cm / 9"

11-945-28-07
 28 cm / 11"

1/2

Metzenbaum-Thorek
 11-945-20-07 -
 11-945-28-07

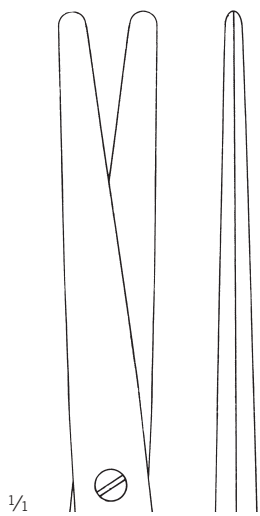

1/1

11-950-21-07

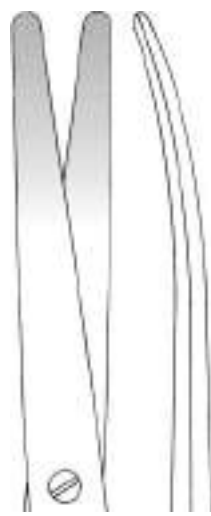

1/1

11-951-21-07

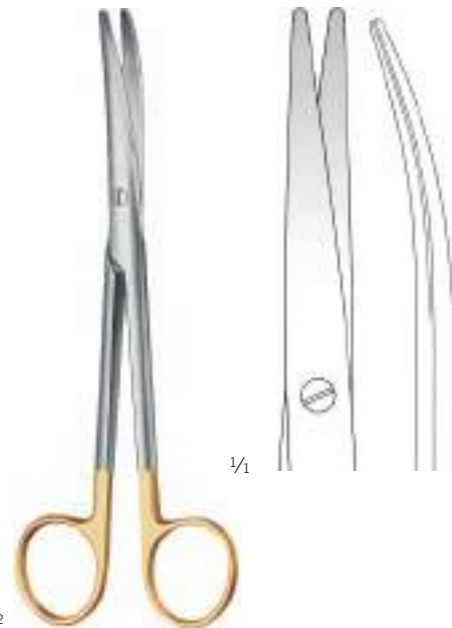

1/1

Mayo-Lexer
 11-953-16-07
 16 cm / 6 2/8"

1/2

Lexer
 11-950-21-07 -
 11-951-21-07
 21 cm / 8 2/8"

1/2

Feine Präparierscheren

Delicate Dissecting Scissors

Tijeras finas de disección

Ciseaux fins à dissection

Forbici fini per dissezione



finoLine



1/2



1/1

11-961-25-07
26 cm / 10 2/8"



1/1

11-961-28-07
28,5 cm / 11 2/8"

Metzenbaum-Fino
11-961-20-07 -
11-961-28-07



1/2

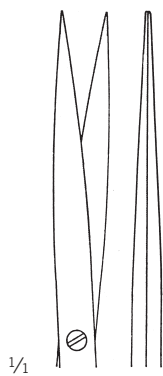

1/1

11-962-18-07
18 cm / 7 1/8"

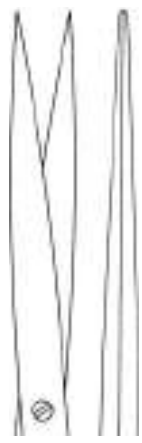

1/1

11-962-20-07
20 cm / 7 7/8"

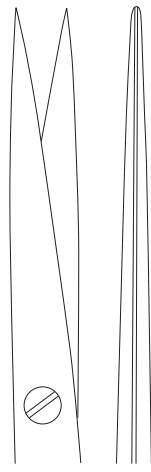

1/1

11-962-23-07
23 cm / 9"

Metzenbaum-Fino
11-962-18-07 -
11-962-20-07



1/2



1/1

Metzenbaum-Lahey
11-965-14-07

14,5 cm / 5 6/8"
schlankes Modell
slender pattern
modelo delgado
modèle gracile
modello delicato

Feine Präparierscheren

Delicate Dissecting Scissors
 Tijeras finas de disección
 Ciseaux fins à dissection
 Forbici fini per dissezione

Scheren

Scissors
 Tijeras
 Ciseaux
 Forbici



finoLine

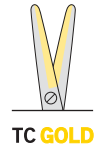

TC GOLD

1/2

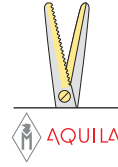

AQUILA

1/2

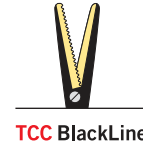

TCC BlackLine

1/2

Toennis-Adson	TCGOLD	AQUILA	TCCBlackLine
17,5 cm / 6 7/8"	11-965-17-07	11-893-17-07	11-921-17-07



1/1

11

Feine Präparierscheren

Delicate Dissecting Scissors

Tijeras finas de disección

Ciseaux fins à dissection

Forbici fini per dissezione



Metzenbaum-Fino

11-965-20-07 -

11-965-23-07

schlankes Modell

slender pattern

modelo delgado

modèle gracile

modello delicato

Face-lift-Scheren

Face-lift Scissors

Tijeras para Face-Lift

Ciseaux pour Face-lift

Forbici per Face-lift

Scheren

Scissors

Tijeras

Ciseaux

Forbici

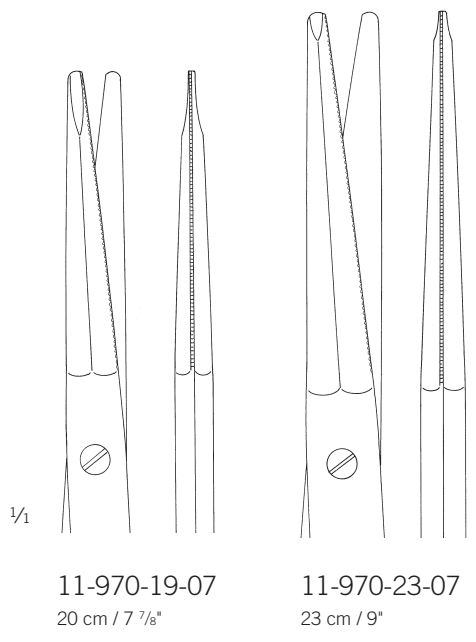

11-970-19-07
20 cm / 7 7/8"

11-970-23-07
23 cm / 9"

1/2

Gorney
11-970-19-07 -
11-970-23-07

eine Schneide gezahnt
one toothed cutting edge
una hoja dentada
une lame dentelée
una lama dentata

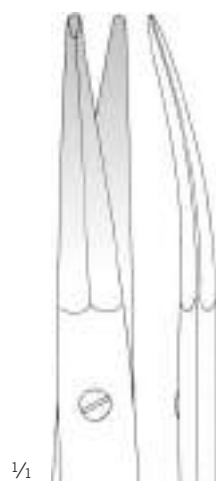

1/2

Rees
11-973-17-07

17 cm / 6 5/8"
eine Schneide gezahnt
one toothed cutting edge
una hoja dentada
une lame dentelée
una lama dentata

Uterusscheren

Uterine Scissors

Tijeras uterinas

Ciseaux utérins

Forbici uterine



	TCGOLD	 AQUILA	TCCBlackLine
22 cm / 8 5/8"	11-979-22-07	11-989-22-07	11-927-22-07

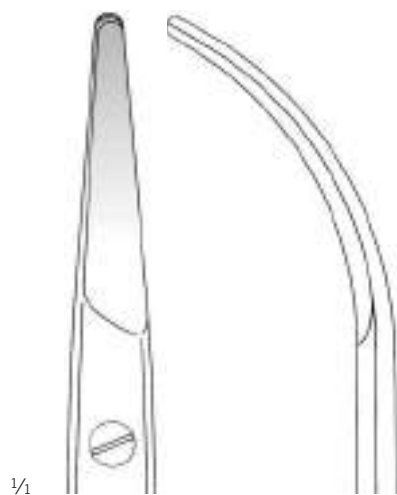

Uterusscheren

Uterine Scissors
Tijeras uterinas
Ciseaux utérins
Forbici uterine

Scheren

Scissors
Tijeras
Ciseaux
Forbici



11



	TCGOLD	 AQUILA	TCCBlackLine
23 cm / 9"	11-979-23-07	11-989-23-07	11-927-23-07

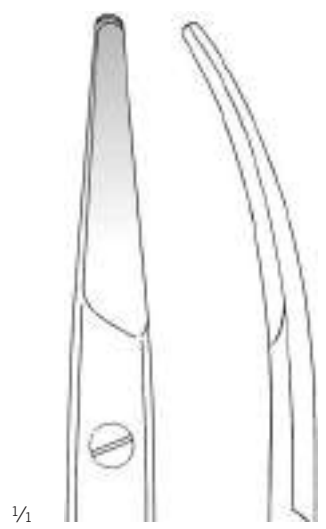

Winkelscheren

Angled Scissors

Tijeras acodadas

Ciseaux coudés

Forbici angolate

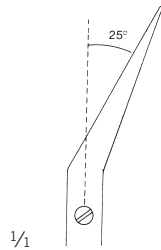

11-985-25-07
19 cm / 7 ⁴/₈"

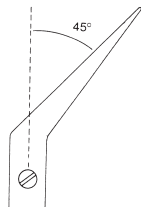

11-985-45-07
18,5 cm / 7 ²/₈"

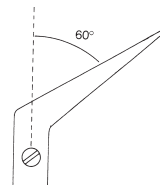

11-985-60-07
18 cm / 7 ¹/₈"

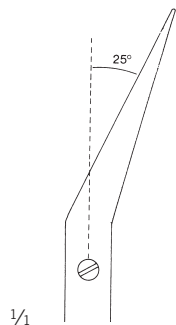

11-987-25-07
23 cm / 9"

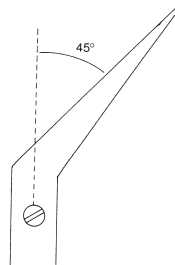

11-987-45-07
23 cm / 9"

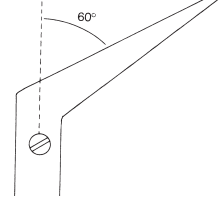

11-987-60-07
22 cm / 8 ⁵/₈"



1/2

De Bakey
11-985-25-07 -
11-987-60-07

Präparierscheren, Drahtscheren

Dissecting Scissors, Wire Cutting Scissors

Tijeras de disección, Tijeras para cortar hilos de acero

Ciseaux à dissection, Ciseaux coupe-fil

Forbici per dissezione, Forbici per tagliare fili metallici

Scheren

Scissors

Tijeras

Ciseaux

Forbici

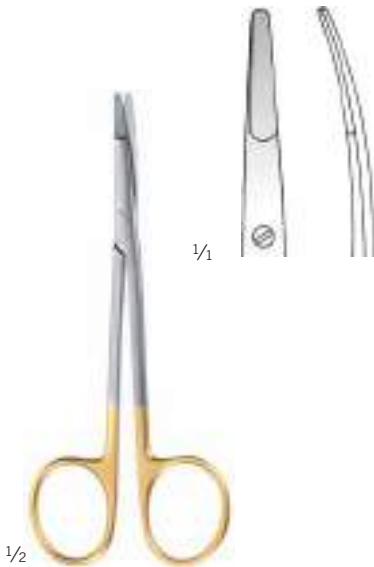

Ragnell
11-991-12-07
12,5 cm / 4 7/8"

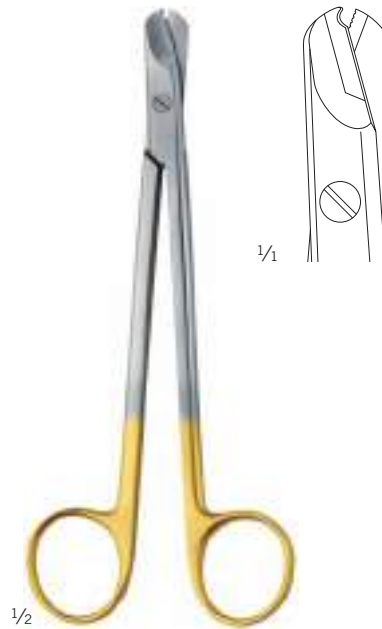

Martin
11-996-16-07

16 cm / 6 2/8"

Drahtschere
Wire cutting scissors
Tijera para alambre
Ciseaux à fils
Forbici per fili

max Ø = 0,5 mm

weicher Draht
hard wire
alambre duro
fil métallique raide
filo rigido

12

Pinzetten
Forceps
Pinzas
Pinces
Pinze









Anatomische Pinzetten

Dissecting Forceps
 Pinzas de disección
 Pinces à dissection
 Pinze per dissezione



1/2

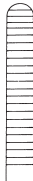
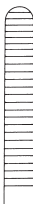

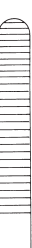
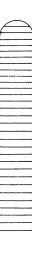

					
	1/1				
	12-100-10-07 10,5 cm / 4 1/8"	12-100-11-07 11,5 cm / 4 4/8"	12-100-13-07 13 cm / 5 1/8"	12-100-14-07 14,5 cm / 5 6/8"	12-100-16-07 16 cm / 6 2/8"



					
	1/1				
	12-100-18-07 18 cm / 7 1/8"	12-100-20-07 20 cm / 7 7/8"	12-100-23-07 23 cm / 9"	12-100-25-07 25 cm / 9 7/8"	12-100-30-07 30,5 cm / 12"

12-100-10-07 -
 12-100-30-07
 Standardmodell
 standard pattern
 modelo estándar
 modèle standard
 modello standard

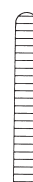

1/2

					
	1/1				
	12-120-11-07 12 cm / 4 6/8"	12-120-13-07 13 cm / 5 1/8"	12-120-14-07 14,5 cm / 5 6/8"	12-120-16-07 16 cm / 6 2/8"	12-120-18-07 18 cm / 7 1/8"

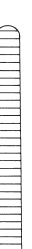
				
	1/1			
	12-120-20-07 20 cm / 7 7/8"	12-120-23-07 23 cm / 9"	12-120-25-07 25 cm / 9 7/8"	12-120-30-07 30 cm / 11 6/8"

12-120-11-07 -
 12-120-30-07
 mittelbreit
 medium width
 de anchura medio
 demi-large
 di media larghezza

Anatomische Pinzetten

Dissecting Forceps
Pinzas de disección
Pincès à dissection
Pinze per dissezione

Pinzetten

Forceps
Pinzas
Pincès
Pinze



12

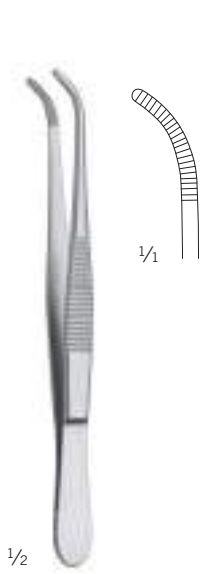

12-122-13-07
13 cm / 5 1/8"

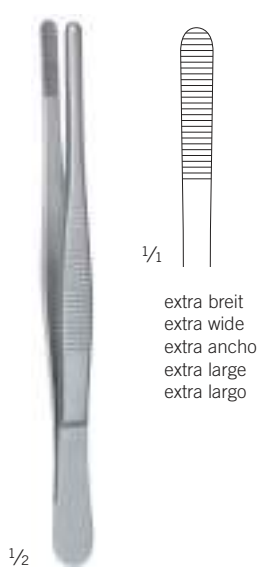

12-123-15-07
14,5 cm / 5 6/8"

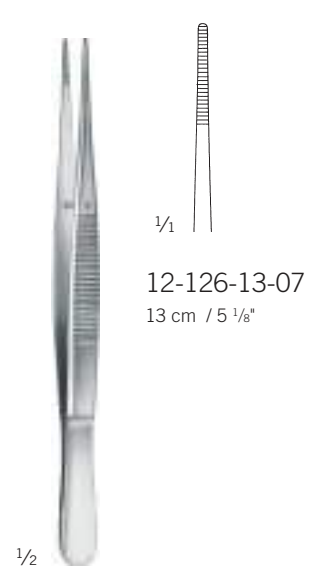

12-126-13-07
13 cm / 5 1/8"



12-126-14-07
14,5 cm / 5 6/8"

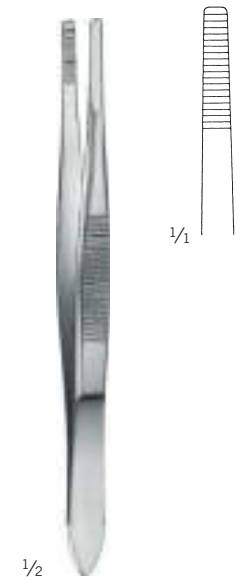

Stille
12-130-15-07
15 cm / 5 7/8"

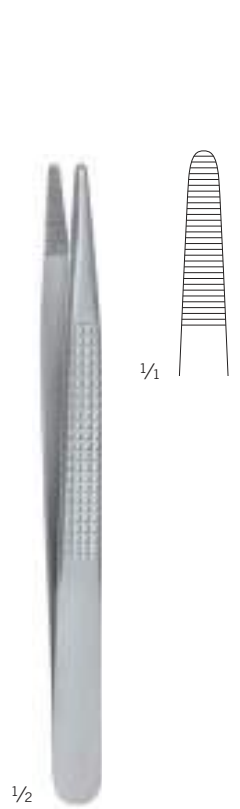

Bonney
12-131-17-07
17 cm / 6 5/8"



12-132-19-07
18,5 cm / 7 2/8"



Brophy
12-133-20-07
20 cm / 7 7/8"



12-134-20-07
20 cm / 7 7/8"

Anatomische Pinzetten

Dissecting Forceps
 Pinzas de disección
 Pincers à dissection
 Pinze per dissezione



1/2

Schweden-Modell
 12-135-13-07 -
 12-135-20-07

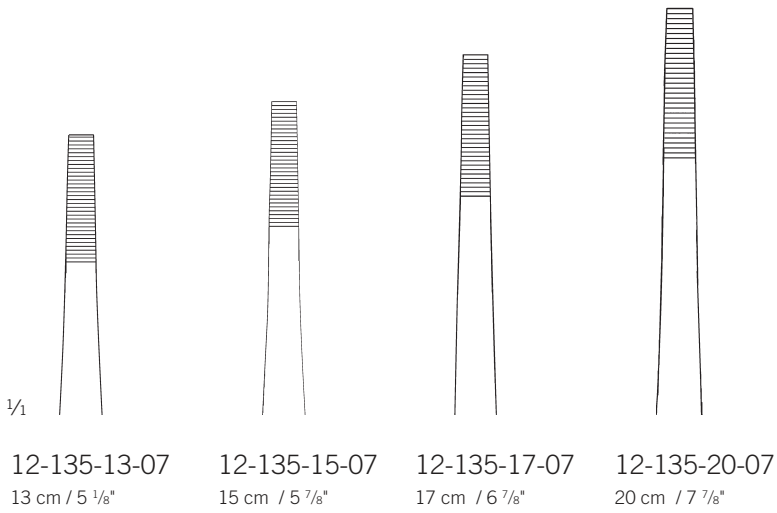

1/1

12-135-13-07
 13 cm / 5 1/8"

12-135-15-07
 15 cm / 5 7/8"

12-135-17-07
 17 cm / 6 7/8"

12-135-20-07
 20 cm / 7 7/8"

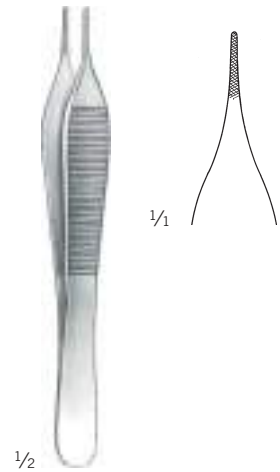

1/2

Mini-Adson
 12-166-12-07
 12 cm / 4 5/8"

1/1

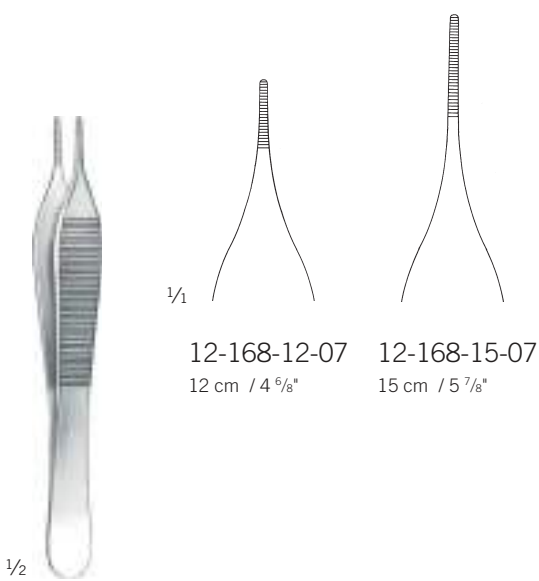

1/1

12-168-12-07
 12 cm / 4 5/8"

12-168-15-07
 15 cm / 5 7/8"

1/2

Adson
 12-168-12-07 -
 12-168-15-07



1/2

McIndoe
 12-170-15-07
 15 cm / 5 7/8"

1/1



1/2

Waugh
 12-171-20-07
 20 cm / 7 7/8"

1/1

Anatomische Pinzetten

Dissecting Forceps
Pinzas de disección
Pincès à dissection
Pinze per dissezione

Pinzetten

Forceps
Pinzas
Pincès
Pinze

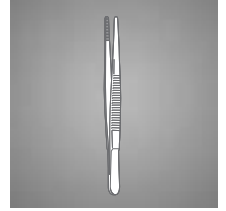

12



Semken
12-172-12-07 -
12-172-15-07

12-184-06-07 -
12-184-10-07
15,5 cm / 6 1/8"

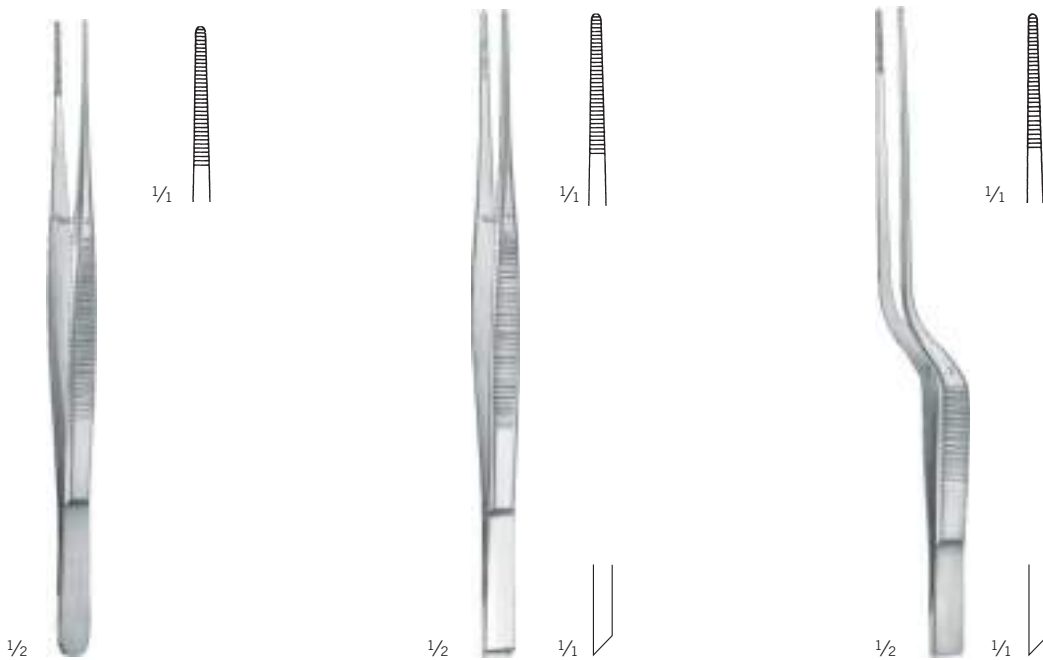

Taylor
12-174-17-07
17 cm / 6 5/8"

Taylor
12-180-17-07
17,5 cm / 6 7/8"
mit Schaberende
with dissector end
con rascador
à rugine
con estremita a forma di raschino

Taylor
12-183-17-07
18,5 cm / 7 2/8"
mit Schaberende
with dissector end
con rascador
à rugine
con estremita a forma di raschino

Anatomische Pinzetten

Dissecting Forceps
Pinzas de disección
Pincers à dissection
Pinze per dissezione

Atrauma



1/1



1/2

12-184-18-07
17,5 cm / 6 7/8"



1/1



1/2

Gerald
12-186-18-07 -
12-187-18-07



12-186-18-07
17,5 cm / 6 7/8"

12-187-18-07
17 cm / 6 5/8"



1/1



1/2

Cushing
12-188-17-07 -
12-189-17-07

12-188-17-07
17,5 cm / 6 7/8"

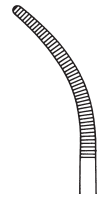

12-189-17-07
17 cm / 6 5/8"



1/1



12-192-18-07
18 cm / 7 1/8"



12-192-21-07
21 cm / 8 2/8"

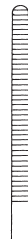

12-192-25-07
25 cm / 9 7/8"



12-192-30-07
30 cm / 11 5/8"

1/2

Potts-Smith
12-192-18-07 -
12-192-30-07

Chirurgische Pinzetten, Anatomische Pinzetten

Tissue Forceps, Dissecting Forceps
 Pinzas de disección con diente, Pinzas de disección
 Pincès à dissection à griffes, Pincès à dissection
 Pinze per dissezione con denti, Pinze per dissezione

Pinzetten

Forceps
 Pinzas
 Pincès
 Pinze

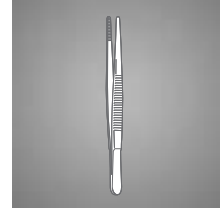

TC GOLD

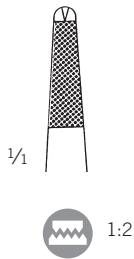

1/2

Bonney
 12-230-17-07
 17,5 cm / 6 7/8"
 Normalprofil
 standard profile
 perfil estándar
 profil normal
 profilo normale

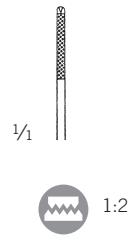

1/2

Gerald
 12-234-17-07
 17,5 cm / 6 7/8"
 Normalprofil
 standard profile
 perfil estándar
 profil normal
 profilo normale

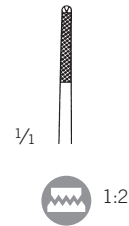

1/2

Gillies
 12-236-15-07
 15,5 cm / 6 1/8"
 Miniprofil
 mini profile
 perfil mini
 profil mini
 mini-profilo



1/2

McIndoe
 12-238-15-07
 15 cm / 5 7/8"
 Miniprofil
 mini profile
 perfil mini
 profil mini
 mini-profilo

12

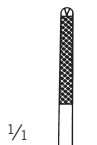

1/2

Semken
 12-240-16-07 -
 12-242-18-07

12-240-16-07
 15,5 cm / 6 1/8"
 Normalprofil
 normal profile
 perfil normal
 profil normal
 profilo normale



12-240-18-07
 17,5 cm / 6 7/8"
 Normalprofil
 normal profile
 perfil normal
 profil normal
 profilo normale



12-242-16-07
 15,5 cm / 6 1/8"
 Miniprofil
 mini profile
 perfil mini
 profil mini
 mini-profilo



12-242-18-07
 17,5 cm / 6 7/8"
 Miniprofil
 mini profile
 perfil mini
 profil mini
 mini-profilo



Chirurgische Pinzetten, Anatomische Pinzetten

Tissue Forceps, Dissecting Forceps

Pinzas de disección con diente, Pinzas de disección

Pinces à dissection à griffes, Pinces à dissection

Pinze per dissezione con denti, Pinze per dissezione

TC GOLD

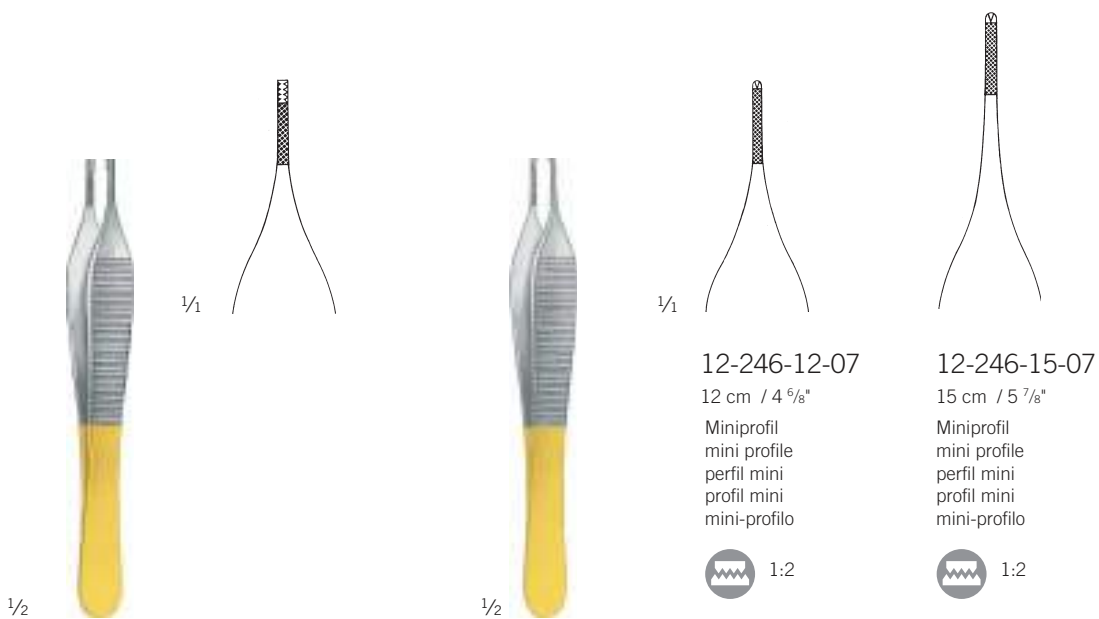

Adson-Brown
12-244-12-07

12 cm / 4 5/8"

Normalprofil
normal profile
perfil normal
profil normal
profilo normale

Adson
12-246-12-07 -
12-246-15-07

12-246-12-07

12 cm / 4 5/8"

Miniprofil
mini profile
perfil mini
profil mini
mini-profilo



12-246-15-07

15 cm / 5 7/8"

Miniprofil
mini profile
perfil mini
profil mini
mini-profilo

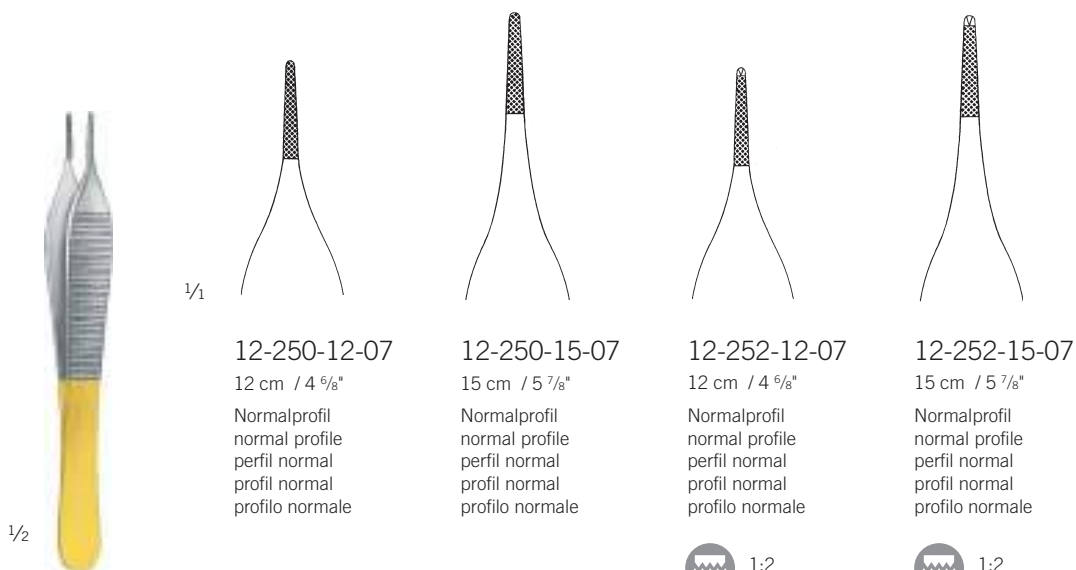

Adson
12-250-12-07 -
12-252-15-07

12-250-12-07

12 cm / 4 5/8"

Normalprofil
normal profile
perfil normal
profil normal
profilo normale

12-250-15-07

15 cm / 5 7/8"

Normalprofil
normal profile
perfil normal
profil normal
profilo normale

12-252-12-07

12 cm / 4 5/8"

Normalprofil
normal profile
perfil normal
profil normal
profilo normale

12-252-15-07

15 cm / 5 7/8"

Normalprofil
normal profile
perfil normal
profil normal
profilo normale



Anatomische Pinzetten

Dissecting Forceps
Pinzas de disección
Pincès à dissection
Pinze per dissezione

Pinzetten

Forceps
Pinzas
Pincès
Pinze



TC GOLD



Normalprofil
normal profile
perfil normal
profil normal
profilo normale

Cushing
12-254-17-07
17,5 cm / 6 7/8"



Normalprofil
normal profile
perfil normal
profil normal
profilo normale

Cushing
12-255-18-07
17 cm / 6 5/8"



Normalprofil
normal profile
perfil normal
profil normal
profilo normale

Cushing-Taylor
12-256-18-07
18,5 cm / 7 2/8"

12

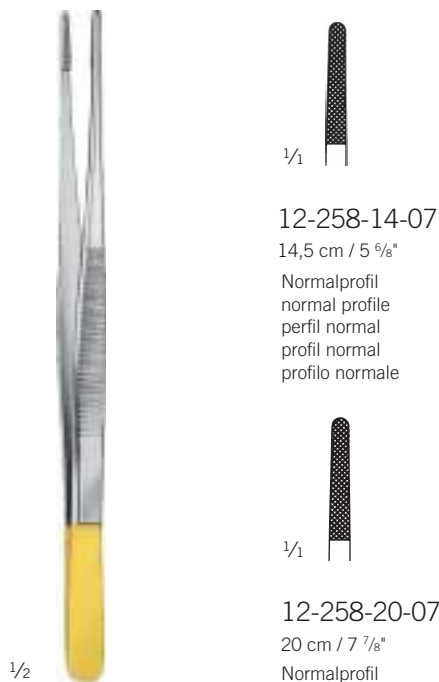

12-258-14-07
14,5 cm / 5 5/8"
Normalprofil
normal profile
perfil normal
profil normal
profilo normale

12-258-15-07
16 cm / 6 2/8"
Normalprofil
normal profile
perfil normal
profil normal
profilo normale

12-258-18-07
18,5 cm / 7 2/8"
Normalprofil
normal profile
perfil normal
profil normal
profilo normale

12-258-20-07
20 cm / 7 7/8"
Normalprofil
normal profile
perfil normal
profil normal
profilo normale

12-258-23-07
23 cm / 9"
Normalprofil
normal profile
perfil normal
profil normal
profilo normale

12-258-25-07
25 cm / 9 7/8"
Normalprofil
normal profile
perfil normal
profil normal
profilo normale

Potts-Smith
12-258-14-07 -
12-258-25-07

Chirurgische Pinzetten, Anatomische Pinzetten

Tissue Forceps, Dissecting Forceps

Pinzas de disección con diente, Pinzas de disección

Pinces à dissection à griffes, Pinces à dissection

Pinze per dissezione con denti, Pinze per dissezione

TC GOLD



1/4					
	12-260-14-07 14,5 cm / 5 7/8" Normalprofil normal profile perfil normal profil normal profilo normale	12-260-16-07 16 cm / 6 2/8" Normalprofil normal profile perfil normal profil normal profilo normale	12-260-18-07 18 cm / 7 1/8" Normalprofil normal profile perfil normal profil normal profilo normale	12-260-20-07 20 cm / 7 7/8" Normalprofil normal profile perfil normal profil normal profilo normale	12-260-25-07 25 cm / 9 7/8" Normalprofil normal profile perfil normal profil normal profilo normale
	1:2	1:2	1:2	1:2	1:2

Oehler
12-260-14-07 -
12-260-25-07



1/4		
	12-266-15-07 15 cm / 5 7/8" Normalprofil normal profile perfil normal profil normal profilo normale	12-266-23-07 23 cm / 9" Normalprofil normal profile perfil normal profil normal profilo normale

Wangenstein
12-266-15-07 -
12-266-23-07

Chirurgische Pinzetten, Atraumatische Pinzetten

Tissue Forceps, Atraumatic Dissecting Forceps

Pinzas de disección con diente, Pinzas de disección atraumática

Pinces à dissection à griffes, Pinces atraumatiques à dissection

Pinze per dissezione con denti, Pinze atraumatiche

Pinzetten

Forceps

Pinzas

Pinces

Pinze

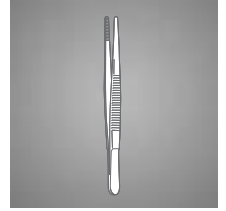

1/2

TC GOLD Atrauma



1/4



	Miniprofil mini profile perfil mini profil mini mini-profilo	Miniprofil mini profile perfil mini profil mini mini-profilo	Normalprofil normal profile perfil normal profil normal profilo normale	Normalprofil normal profile perfil normal profil normal profilo normale
	1,5 mm	2,0 mm	2,7 mm	3,5 mm
16 cm / 6 2/8"	12-270-15-07	12-272-15-07	12-273-15-07	12-274-15-07
20 cm / 7 7/8"	12-270-19-07	12-272-19-07	12-273-19-07	12-274-19-07
24,5 cm / 9 5/8"	12-270-24-07	12-272-24-07	12-273-24-07	12-274-24-07

12

DeBaKey
12-270-15-07 -
12-274-24-07



1/2

Jaboma
12-276-18-07
18 cm / 7 1/8"

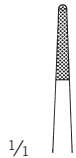

1/4



1/2

Jaboma
12-278-18-07
18 cm / 7 1/8"



1/4



1:2



1/2

Jaboma
12-279-18-07
18 cm / 7 1/8"

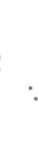

1/4



1:2

Anatomische Pinzetten, Atraumatische Pinzetten

Dissecting Forceps, Atraumatic Dissecting Forceps

Pinzas de disección, Pinzas de disección atraumática

Pinces à dissection, Pinces atraumatiques à dissection

Pinze per dissezione, Pinze atraumatiche



1/2

Atrauma



1/1



	1,0 mm	1,5 mm	1,8 mm	2,8 mm
16 cm / 6 2/8"	12-280-16-09	12-282-16-09	12-284-16-09	12-288-16-09
20,5 cm / 8 1/8"	12-280-20-09	12-282-20-09	12-284-20-09	12-288-20-09
24,5 cm / 9 5/8"	12-280-24-09	12-282-24-09	12-284-24-09	12-288-24-09

DeBakey
12-280-16-09 -
12-288-24-09



1/2



1/1



	Atrauma	1,0 x 0,5 mm	1,0 mm
18 cm / 7 1/8"	Ø 1,2 mm		
	St 12-285-18-07	12-286-18-07	12-287-18-07
20 cm / 7 7/8"	Ti 12-285-18-09	12-286-18-09	12-287-18-09
	St 12-285-20-07	12-286-20-07	12-287-20-07
	Ti 12-285-20-09	12-286-20-09	12-287-20-09

Gerald
12-285-18-07 -
12-287-20-09

Chirurgische Pinzetten

Tissue Forceps
 Pinzas de disección con diente
 Pincers à dissection à griffes
 Pinze per dissezione con denti

Pinzetten

Forceps
 Pinzas
 Pincers
 Pinze

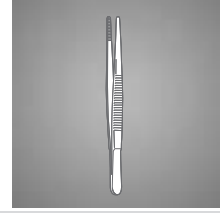

1/2

12-301-10-07 -
 12-301-30-07

Standardmodell
 standard pattern
 modelo estándar
 modèle standard
 modello standard

1/1	1/1	1/1	1/1	1/1
12-301-10-07 10,5 cm / 4 1/8"	12-301-11-07 12 cm / 4 5/8"	12-301-13-07 13 cm / 5 1/8"	12-301-14-07 14,5 cm / 5 5/8"	12-301-16-07 16 cm / 6 2/8"
1:2	1:2	1:2	1:2	1:2

1/1	1/1	1/1	1/1	1/1
12-301-18-07 18 cm / 7 1/8"	12-301-20-07 20,5 cm / 8 1/8"	12-301-23-07 23 cm / 9"	12-301-25-07 25 cm / 9 7/8"	12-301-30-07 30,5 cm / 12"
1:2	1:2	1:2	1:2	1:2



1/2

12-302-11-07 -
 12-302-25-07

1/1	1/1	1/1	1/1
12-302-11-07 12 cm / 4 5/8"	12-302-13-07 13 cm / 5 1/8"	12-302-14-07 14,5 cm / 5 5/8"	12-302-16-07 16 cm / 6 2/8"
2:3	2:3	2:3	2:3
1/1	1/1	1/1	1/1
12-302-17-07 17 cm / 6 5/8"	12-302-18-07 18 cm / 7 1/8"	12-302-20-07 20,5 cm / 8 1/8"	12-302-25-07 25 cm / 9 7/8"
2:3	2:3	2:3	2:3

12

Chirurgische Pinzetten

Tissue Forceps

Pinzas de disección con diente

Pinces à dissection à griffes

Pinze per dissezione con denti



1/2

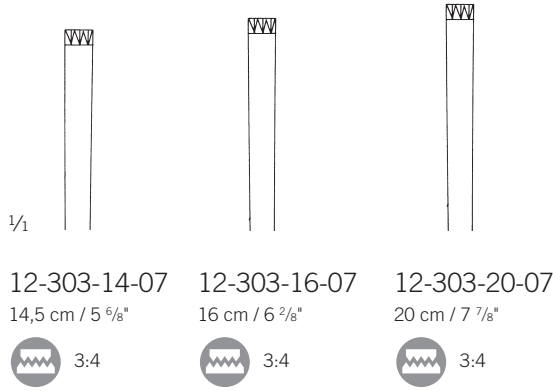

12-303-14-07
14,5 cm / 5 6/8"

12-303-16-07
16 cm / 6 2/8"

12-303-20-07
20 cm / 7 7/8"

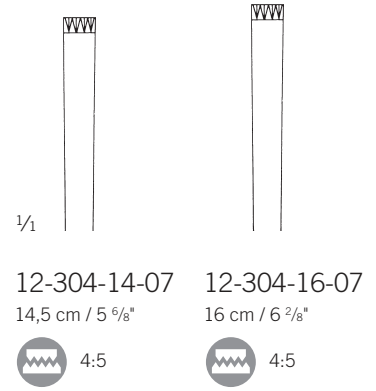

12-304-14-07
14,5 cm / 5 6/8"

12-304-16-07
16 cm / 6 2/8"

1/2

12-303-14-07 -
12-303-20-07

12-304-14-07 -
12-304-16-07



1/2

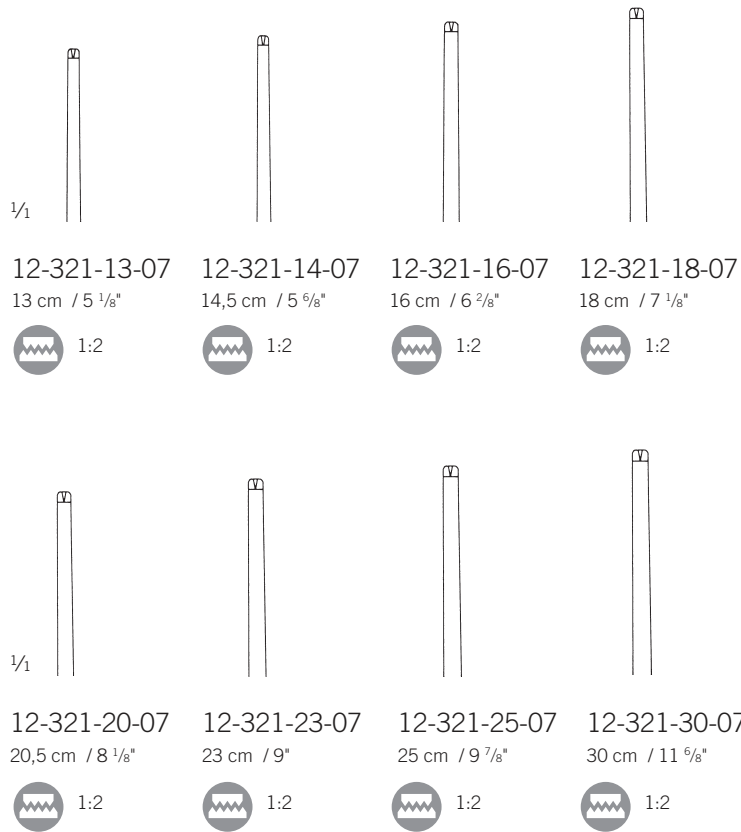

12-321-13-07
13 cm / 5 1/8"

12-321-14-07
14,5 cm / 5 6/8"

12-321-16-07
16 cm / 6 2/8"

12-321-18-07
18 cm / 7 1/8"

12-321-20-07
20,5 cm / 8 1/8"

12-321-23-07
23 cm / 9"

12-321-25-07
25 cm / 9 7/8"

12-321-30-07
30 cm / 11 6/8"

12-321-13-07 -
12-321-30-07

mittelbreit
medium
medio
moyen
medio

Chirurgische Pinzetten

Tissue Forceps
 Pinzas de disección con diente
 Pincers à dissection à griffes
 Pinze per dissezione con denti

Pinzetten

Forceps
 Pinzas
 Pincers
 Pinze

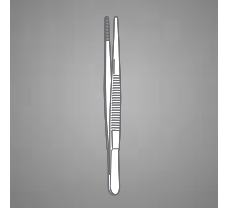

12



12-323-15-07
 14,5 cm / 5 5/8"

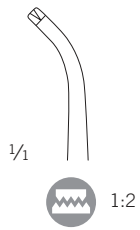

12-326-13-07 -
 12-326-14-07

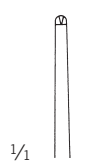

12-326-13-07
 13 cm / 5 1/8"

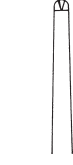

12-326-14-07
 14,5 cm / 5 5/8"



Stille
 12-331-15-07 -
 12-332-15-07
 15 cm / 5 7/8"



12-331-15-07



12-332-15-07



Adlerkreutz
 12-366-15-07 -
 12-367-25-07

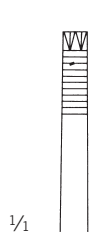

12-366-15-07
 15,5 cm / 6 1/8"

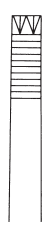

12-366-20-07
 20,5 cm / 8 1/8"



12-367-15-07
 15,5 cm / 6 1/8"



12-367-20-07
 20 cm / 7 7/8"

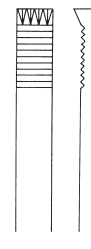

12-367-25-07
 25 cm / 9 7/8"



Chirurgische Pinzetten

Tissue Forceps

Pinzas de disección con diente

Pinces à dissection à griffes

Pinze per dissezione con denti

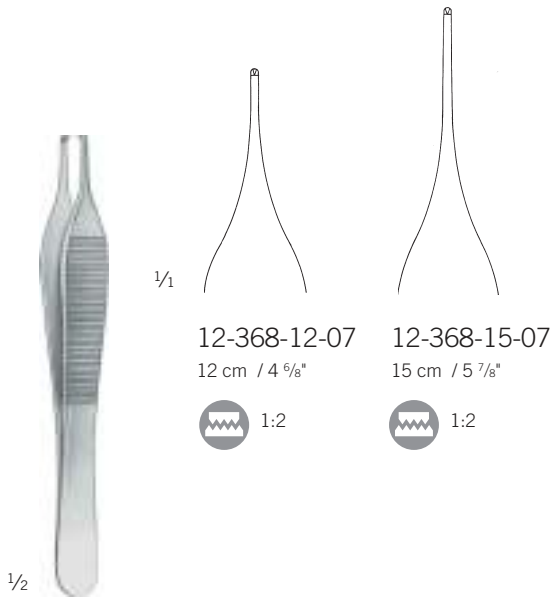

Adson
12-368-12-07 -
12-368-15-07

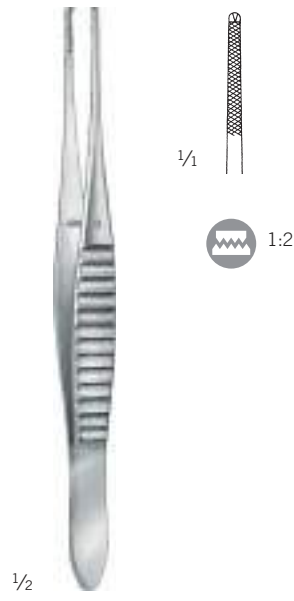

Gillies
12-370-15-07
15,5 cm / 6 1/8"

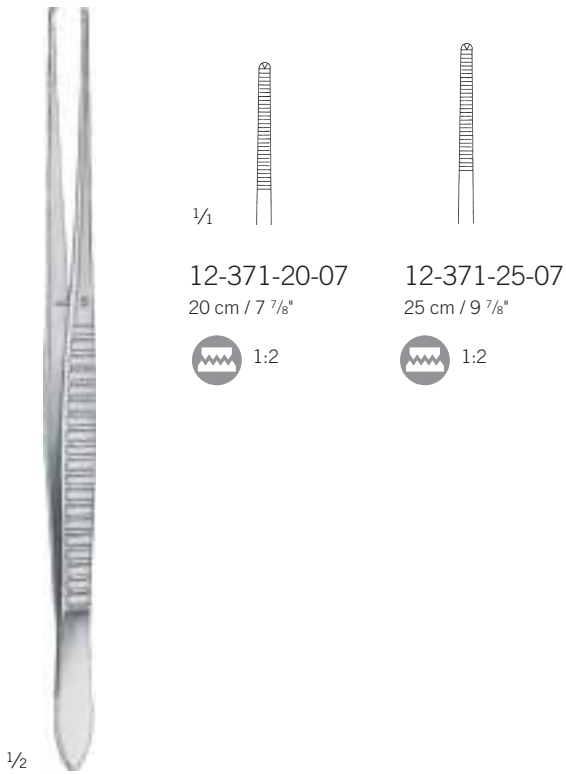

Waugh
12-371-20-07 -
12-371-25-07

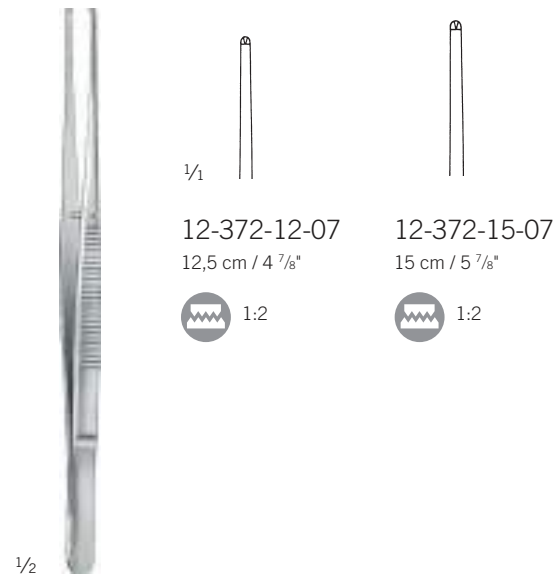

Semken
12-372-12-07 -
12-372-15-07

Chirurgische Pinzetten, Mikropinzetten

Tissue Forceps, Micro Forceps

Pinzas de disección con diente, Micro Pinzas

Pinces à dissection à griffes, Micro-Pinces

Pinze per dissezione con denti, Micro-Pinze

Pinzetten

Forceps

Pinzas

Pinces

Pinze

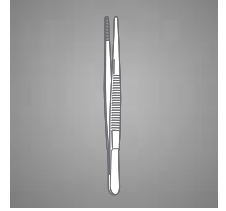

Brophy
12-373-20-07
20 cm / 7 7/8"

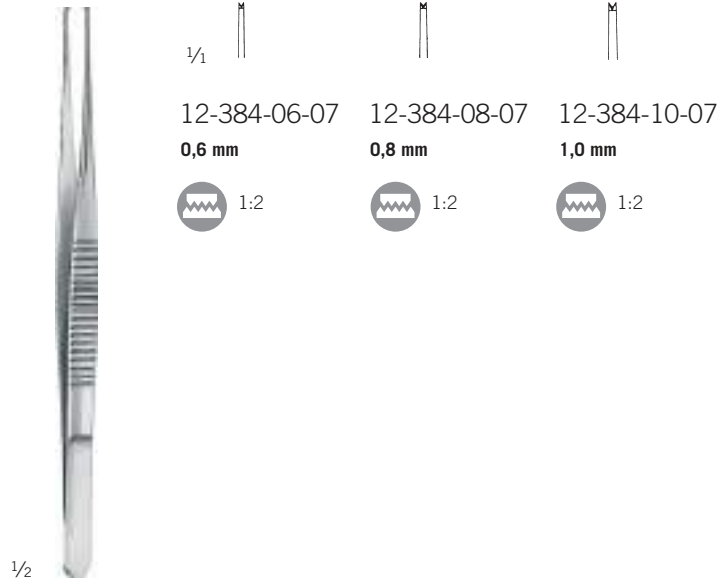

12-384-06-07 -
12-384-10-07
15,5 cm / 6 1/8"



Taylor
12-374-17-07
17,5 cm / 6 7/8"



Taylor
12-380-17-07
17 cm / 6 6/8"
mit Schaberende
with dissector end
con rascador
à rugine
con estremita a forma di raschino



Taylor
12-383-17-07
18,5 cm / 7 2/8"
mit Schaberende
with dissector end
con rascador
à rugine
con estremita a forma di raschino

12

Anatomische Pinzetten, Chirurgische Pinzetten

Dissecting Forceps, Tissue Forceps

Pinzas de disección, Pinzas de disección con diente

Pinces à dissection, Pinces à dissection à griffes



1/2

Gerald
12-386-17-07 -
12-387-17-07

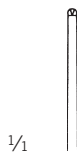

1/1

12-386-17-07
17,5 cm / 6 7/8"



1:2



12-386-23-07
23 cm / 9"



1:2



12-387-17-07
17 cm / 6 5/8"



1:2



1/2

Cushing
12-388-17-07
18 cm / 7 1/8"



1/1



1:2



1/2

Potts-Smith
12-392-18-07 -
12-392-30-07

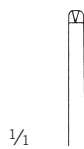

1/1

12-392-18-07
18 cm / 7 1/8"



1:2



12-392-21-07
21 cm / 8 2/8"



1:2



12-392-25-07
25 cm / 9 7/8"



1:2



12-392-30-07
30 cm / 11 5/8"



1:2

Anatomische Pinzetten, Chirurgische Pinzetten

Dissecting Forceps, Tissue Forceps
 Pinzas de disección, Pinzas de disección con diente
 Pincès à dissection, Pincès à dissection à griffes

Pinzetten

Forceps
 Pinzas
 Pincès
 Pinze

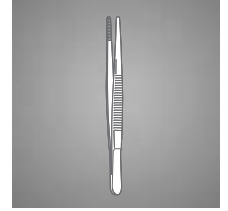

12

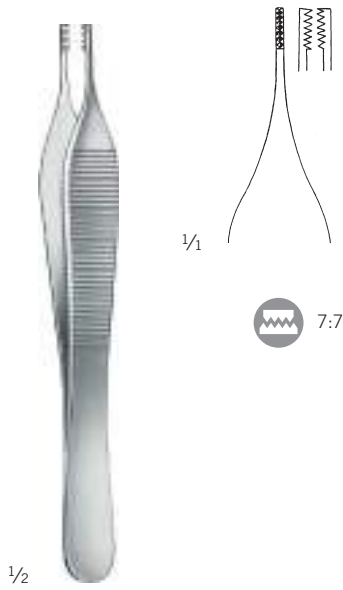

Adson-Brown
 12-400-12-07
 12 cm / 4 5/8"

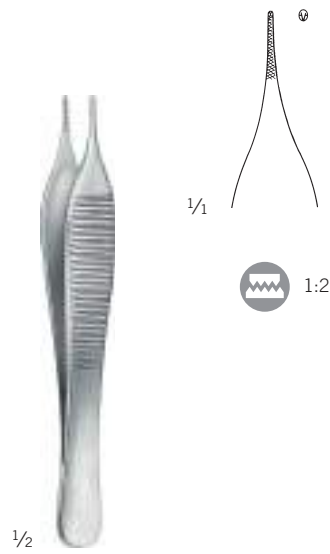

Mini-Adson
 12-402-12-07
 12 cm / 4 5/8"

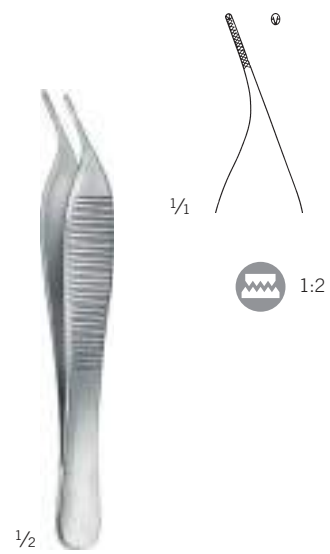

Mini-Adson
 12-403-12-07
 12 cm / 4 5/8"

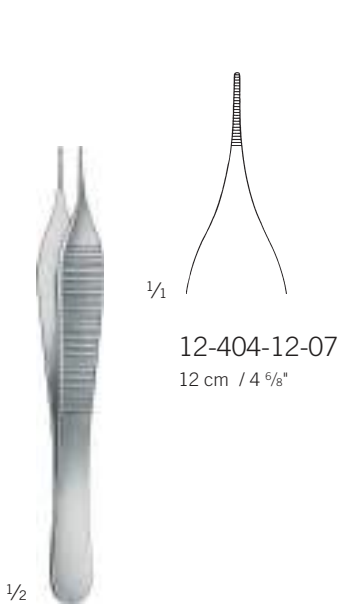

Mikro-Adson
 12-404-12-07 -
 12-404-15-07

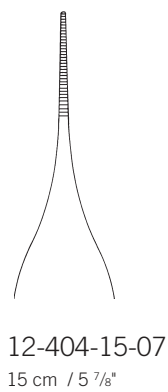

12-404-15-07
 15 cm / 5 7/8"

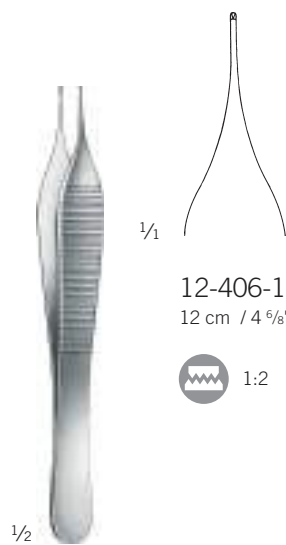

Mikro-Adson
 12-406-12-07 -
 12-406-15-07

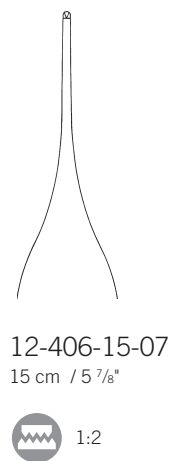

12-406-15-07
 15 cm / 5 7/8"

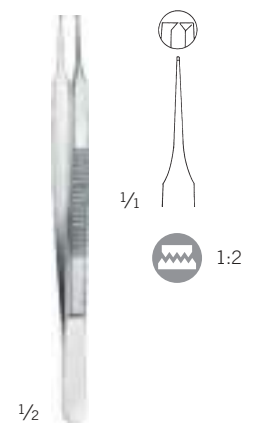

12-408-11-07
 10,5 cm / 4 1/8"
 sehr feine Zähne
 very fine teeth
 dientes muy finos
 dents très fines
 denti molto fini

Uhrmacher-Pinzetten

Jeweler Type Forceps

Pinzas de relojero

Pinces d'horloger

Pinze da orologiaio

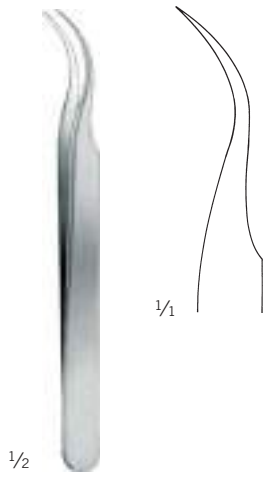

12-409-12-07

12 cm / 4 5/8"

Fig. 7

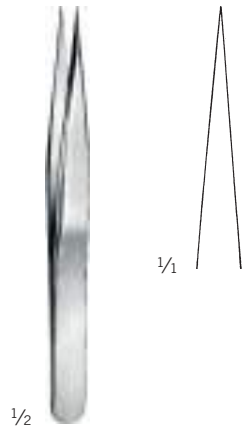

12-410-12-07

12 cm / 4 5/8"

Fig. 3

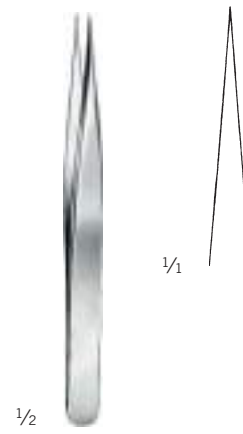

12-412-11-07

12 cm / 4 5/8"

Fig. 3 C

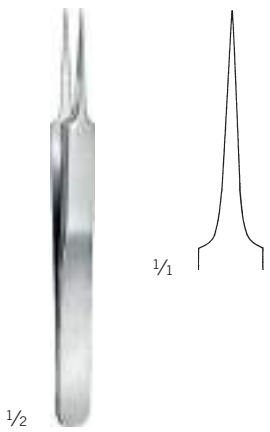

12-414-11-07

11 cm / 4 3/8"

Fig. 5

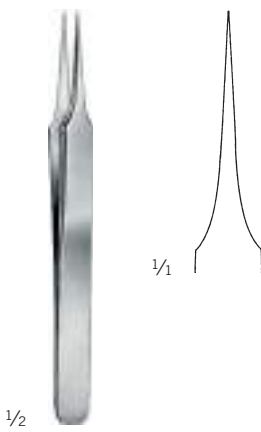

12-416-11-07

11 cm / 4 3/8"

Fig. 4

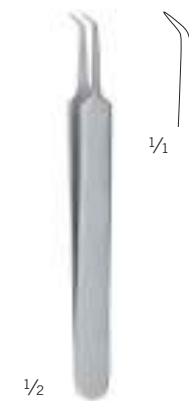

12-418-11-07

11 cm / 4 3/8"

Chirurgische Pinzetten

Tissue Forceps
 Pinzas de disección con diente
 Pincés à dissection à griffes
 Pinze per dissezione con denti

Pinzetten

Forceps
 Pinzas
 Pincés
 Pinze

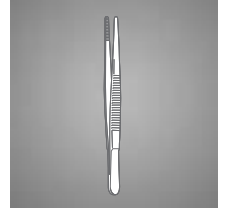

1/2



1/1

12-420-15-07
 15 cm / 5 7/8"



12-420-20-07
 20 cm / 7 7/8"



12-420-25-07
 25,5 cm / 10"

Russ. Modell
 12-420-15-07 -
 12-420-25-07



1/2



1/1

12-426-14-07
 14,5 cm / 5 6/8"

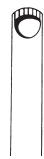

12-426-16-07
 16 cm / 6 2/8"



12-426-20-07
 20,5 cm / 8 1/8"



12-426-25-07
 25 cm / 9 7/8"

Durante
 12-426-14-07 -
 12-426-25-07



1/2



1/1

12-444-18-07
 18 cm / 7 1/8"



3:4



12-444-26-07
 26 cm / 10 2/8"



3:4

Stille-Barraya
 12-444-18-07 -
 12-444-26-07

12

Chirurgische Pinzetten, Anatomische Pinzetten

Tissue Forceps, Dissecting Forceps

Pinzas de disección con diente, Pinzas de disección

Pinces à dissection à griffes, Pinces à dissection

Pinze per dissezione con denti, Pinze per dissezione

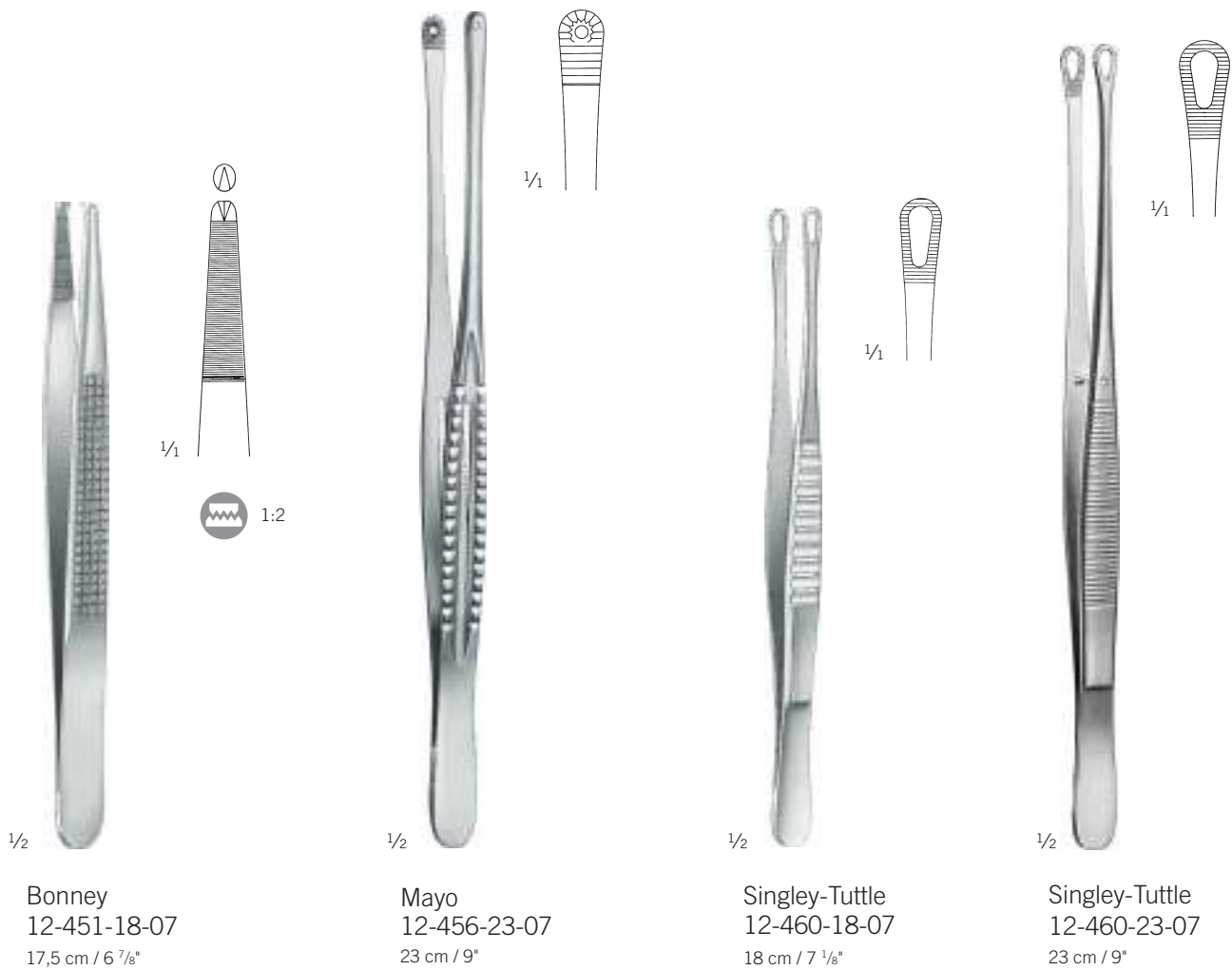

Chirurgische Pinzetten

Tissue Forceps

Pinzas de disección con diente

Pinces à dissection à griffes

Pinze per dissezione con denti

Pinzetten

Forceps

Pinzas

Pinces

Pinze

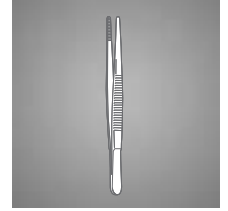

12



Nelson
12-466-23-07
23 cm / 9"



Resano
12-467-23-07
23 cm / 9"

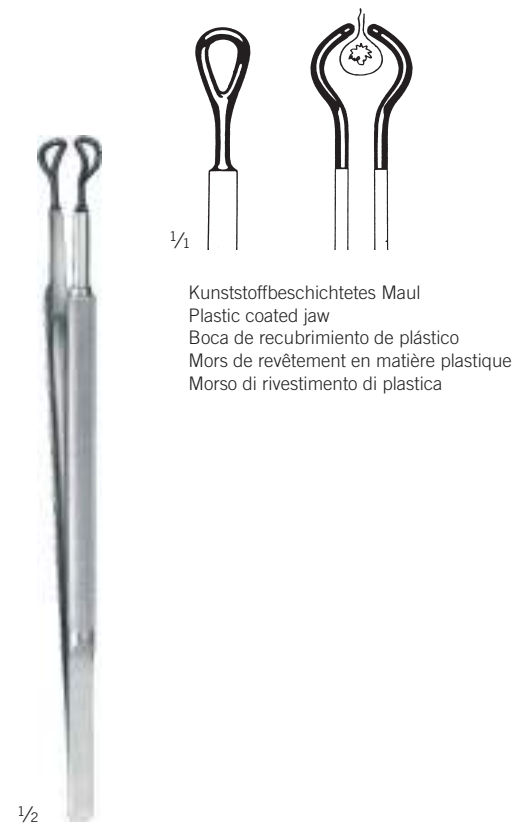

Hepp-Scheidel
12-468-18-07
18 cm / 7 1/8"
Tubenfasspinzette
Tubal forceps
Pinza para tubos
Pince pour saisir les trompes
pinza oer afferare tubi

Anatomische Pinzetten, Chirurgische Pinzetten

Dissecting Forceps, Tissue Forceps

Pinzas de disección, Pinzas de disección con dientes

Pinces à dissection, Pinces à dissection à griffes

Pinze per dissezione, Pinze per dissezione con denti



1/2

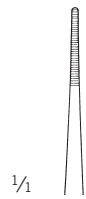

1/4

12-502-10-07
10 cm / 3 5/8"



12-503-10-07
10 cm / 3 7/8"



12-505-10-07
9,5 cm / 3 5/8"



12-512-10-07
10 cm / 3 7/8"



12-513-10-07
10 cm / 3 7/8"



12-515-10-07
9,5 cm / 3 5/8"



1:2



1:2



1:2

12-502-10-07 -
12-515-10-07

fein
delicate
fino
fin
fino

Kurze Mikropinzetten

Short Micro Forceps
Micro Pinzas, corto
Micro-Pinces, court
Micro-Pinze, corto

Pinzetten

Forceps
Pinzas
Pinces
Pinze

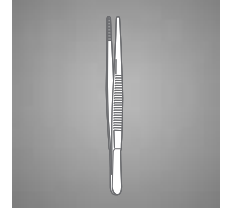

12



1/2

12-552-01-07 -
12-553-06-07
11 cm / 4 3/8"

1/1			
∅	0.15 mm	0.20 mm	0.30 mm
St	12-552-01-07	12-552-02-07	12-552-03-07

1/1			
∅	0.50 mm	1.2 mm	
St	12-553-01-07	12-553-05-07	12-553-06-07

1/1			
	VD	VD	VD
∅	0.10 mm	0.20 mm	0.30 mm
gewinkelt/angled/ acodada/angulée/ angolata	10°	10°	10°
St	12-552-04-07	12-552-05-07	12-552-06-07



1/2

12-552-07-07 -
12-553-09-07
11 cm / 4 3/8"

1/1			
∅	0.15 mm	0.20 mm	0.30 mm
St	12-552-07-07	12-552-08-07	12-552-09-07

1/1			
∅	0.50 mm	1.2 mm	
St	12-553-07-07	12-553-08-07	12-553-09-07

1/1			
	VD	VD	VD
∅	0.10 mm	0.20 mm	0.30 mm
gewinkelt/angled/ acodada/angulée/ angolata	10°	10°	10°
St	12-552-10-07	12-552-11-07	12-552-12-07

Mikropinzetten, Gefäß-Dilatationspinzetten

Micro Forceps, Micro dilating forceps
 Micro Pinzas, Micro pinza de dilatación
 Micro-Pinces, Micro pince à dilater
 Micro-Pinze, Micro pinze per dilatazione



1/2

Jeweler mod.
 12-560-00-07 -
 12-561-90-07

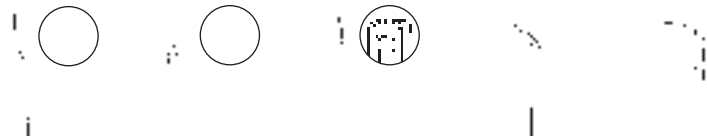

		VD	VD	Pierse	45°	90°
11 cm / 4 3/8"	Ø 0.30 mm	0.20 mm	0.30 mm	0.30 mm	0.30 mm	0.30 mm
	St	12-560-00-07	12-560-02-07	12-560-03-07	12-560-05-07	12-560-90-07
13,5 cm / 5 3/8"	St	12-561-00-07	12-561-02-07	12-561-03-07	12-561-05-07	12-561-90-07



1/2

12-562-00-07 -
 12-563-05-07



1/4



			45°		VD	Pierse
15 cm / 5 7/8"	Ø 0.30 mm	0.30 mm	0.30 mm	1.0 x 0.5 mm	0.30 mm	0.30 mm
	St	12-562-00-07	12-562-01-07	12-562-02-07	12-562-03-07	12-562-04-07
18 cm / 7 1/8"	St	12-563-00-07	12-563-01-07	12-563-02-07	12-563-03-07	12-563-04-07

Mikropinzetten, Gefäß-Dilatationspinzetten

Micro Forceps, Micro dilating forceps
 Micro Pinzas, Micro pinza de dilatación
 Micro-Pinces, Micro pince à dilater
 Micro-Pinze, Micro pinze per dilatazione

Pinzetten

Forceps
 Pinzas
 Pinces
 Pinze

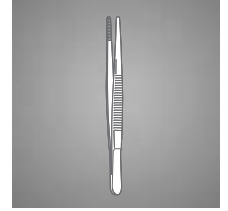

1/2



	Ø	0.40 mm	0.40 mm	0.70 mm	0.70 mm	0.80 mm	0.80 mm
15 cm / 5 7/8"	St	12-564-15-07	12-565-15-07	12-566-15-07	12-567-15-07		
	Ti	12-578-15-09	12-579-15-09			12-580-15-09	12-581-15-09
18 cm / 7 1/8"	St	12-564-18-07	12-565-18-07	12-566-18-07	12-567-18-07		
	Ti	12-578-18-09	12-579-18-09			12-580-18-09	12-581-18-09
21 cm / 8 3/8"	St			12-566-21-07	12-567-21-07		
	Ti					12-580-21-09	12-581-21-09
23 cm / 9"	St			12-566-23-07	12-567-23-07		
	Ti					12-580-23-09	12-581-23-09
25 cm / 9 7/8"	St			12-566-25-07	12-567-25-07		
	Ti					12-580-25-09	12-581-25-09

12-564-15-07 -
 12-581-25-09

12



1/2



	Ø	0.30 mm	0.40 mm	45°	1.0 x 0.5 mm	VD	Pierse
15 cm / 5 7/8"	St	12-591-00-07	12-591-01-07	12-591-02-07	12-591-03-07	12-591-04-07	12-591-05-07
	St	12-592-00-07	12-592-01-07	12-592-02-07	12-592-03-07	12-592-04-07	12-592-05-07

12-591-01-07 -
 12-592-05-07

Kurze Mikropinzetten

Short Micro Forceps

Micro Pinzas, corto

Micro-Pinces, court

Micro-Pinze, corto



1/2

12-572-00-07 -
12-572-09-07



Counter Balance



diamond-coated

1/1



	Ø	0.40 mm	0.40 mm	0.70 mm	0.70 mm
18 cm / 7 1/8"	St	12-572-00-07	12-572-01-07	12-572-02-07	12-572-03-07
21 cm / 8 2/8"	St			12-572-04-07	12-572-05-07
23 cm / 9"	St			12-572-06-07	12-572-07-07
25 cm / 9 7/8"	St			12-572-08-07	12-572-09-07



1/2

12-572-15-07 -
12-573-19-07



Counter Balance



diamond-coated

1/1



	Ø	1.0 x 0.5 mm	1.0 x 0.5 mm	1.0 x 0.5 mm	2.0 x 1.0 mm	2.0 x 1.0 mm	Atrauma®
18 cm / 7 1/8"	St	12-572-15-07	12-573-00-07	12-573-01-07	12-573-02-07	12-573-03-07	12-573-04-07
21 cm / 8 2/8"	St	12-572-20-07	12-573-05-07	12-573-06-07	12-573-07-07	12-573-08-07	12-573-09-07
23 cm / 9"	St	12-572-25-07	12-573-10-07	12-573-11-07	12-573-12-07	12-573-13-07	12-573-14-07
25 cm / 9 7/8"	St	12-572-30-07	12-573-15-07	12-573-16-07	12-573-17-07	12-573-18-07	12-573-19-07

Kurze Mikropinzetten

Short Micro Forceps
Micro Pinzas, corto
Micro-Pinces, court
Micro-Pinze, corto

Pinzetten

Forceps
Pinzas
Pinces
Pinze

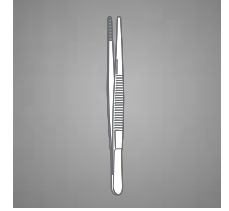

12



	mm	1:2	1:2	1:2	1:2	1:2	1:2
15 cm / 5 7/8"	Ø	0.40 mm	0.40 mm	0.70 mm	0.70 mm	0.80 mm	0.80 mm
	St	12-568-15-07	12-569-15-07	12-570-15-07	12-571-15-07		
	Ti	12-582-15-09	12-583-15-09			12-584-15-09	12-585-15-09
18 cm / 7 1/8"	St	12-568-18-07	12-569-18-07	12-570-18-07	12-571-18-07		
	Ti	12-582-18-09	12-583-18-09			12-584-18-09	12-585-18-09
21 cm / 8 2/8"	St			12-570-21-07	12-571-21-07		
	Ti					12-584-21-09	12-585-21-09
23 cm / 9"	St			12-570-23-07	12-571-23-07		

1/2

12-568-15-07 -
12-585-21-09



	mm	1:2	1:2	1:2	1:2	1:2	Atrauma 
15 cm / 5 7/8"	Ø	1.0 x 0.5 mm	1.0 x 0.5 mm	1.0 x 0.5 mm	2.0 x 1.0 mm	2.0 x 1.0 mm	1.2 mm
	St	12-575-15-07	12-574-15-07	12-774-15-07	12-576-15-07	12-776-15-07	12-589-15-07
	Ti	12-587-15-09	12-586-15-09	12-786-15-09	12-588-15-09	12-787-15-09	12-590-15-09
18 cm / 7 1/8"	St	12-575-18-07	12-574-18-07	12-774-18-07	12-576-18-07	12-776-18-07	12-589-18-07
	Ti	12-587-18-09	12-586-18-09	12-786-18-09	12-588-18-09	12-787-18-09	12-590-18-09
21 cm / 8 2/8"	St	12-575-21-07	12-574-21-07	12-774-21-07	12-576-21-07	12-776-21-07	12-589-21-07
	Ti	12-587-21-09	12-586-21-09	12-786-21-09	12-588-21-09	12-787-21-09	12-590-21-09
23 cm / 9"	St	12-575-23-07	12-574-23-07	12-774-23-07	12-576-23-07	12-776-23-07	12-589-23-07
	Ti	12-587-23-09	12-586-23-09	12-786-23-09	12-588-23-09	12-787-23-09	12-590-23-09
25 cm / 9 7/8"	St	12-575-25-07	12-574-25-07	12-774-25-07	12-576-25-07	12-776-25-07	12-589-25-07
	Ti	12-587-25-09	12-586-25-09	12-786-25-09	12-588-25-09	12-787-25-09	12-590-25-09

1/2

12-574-15-07 -
12-787-25-09

Splitterpinzetten

Splinter Forceps
Pinzas para espinas
Pinces à échardes
Pinze per scheggie

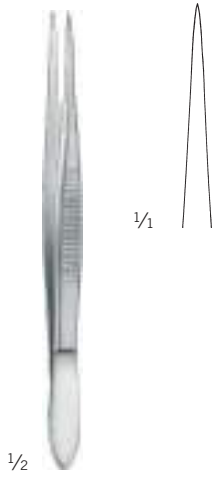

12-600-12-07

12,5 cm / 4 7/8"

glattes Maul
smooth jaw
boca lisa
mors lisse
morso liscio

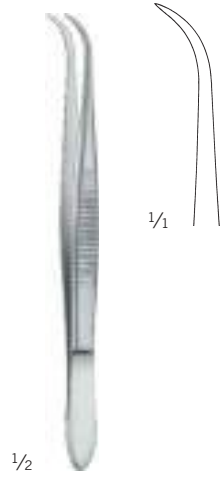

12-601-12-07

12,5 cm / 4 7/8"

glattes Maul
smooth jaw
boca lisa
mors lisse
morso liscio



12-604-09-07 -
12-604-12-07

gerieftes Maul
serrated jaw
boca estriada
mors strié
morso striato

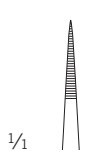

12-604-09-07

9 cm / 3 4/8"



12-604-11-07

10,5 cm / 4 1/8"



12-604-12-07

12,5 cm / 4 7/8"



12-605-09-07 -
12-605-12-07

gerieftes Maul
serrated jaw
boca estriada
mors strié
morso striato

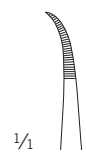

12-605-09-07

9 cm / 3 4/8"

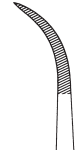

12-605-12-07

12,5 cm / 4 7/8"

Splitterpinzetten

Splinter Forceps
Pinzas para espinas
Pincas à échardes
Pinze per scheggie

Pinzetten

Forceps
Pinzas
Pincas
Pinze



12



12-616-16-07

15,5 cm / 6 1/8"

Mikro-Knüpfpinzette, glattes Maul
Micro Tying Forceps, smooth jaw
Micro Pinza para anudar, boca lisa
Micro-Pince à poser des ligatures, mors lisse
Micro-Pinza per legature, morso liscio

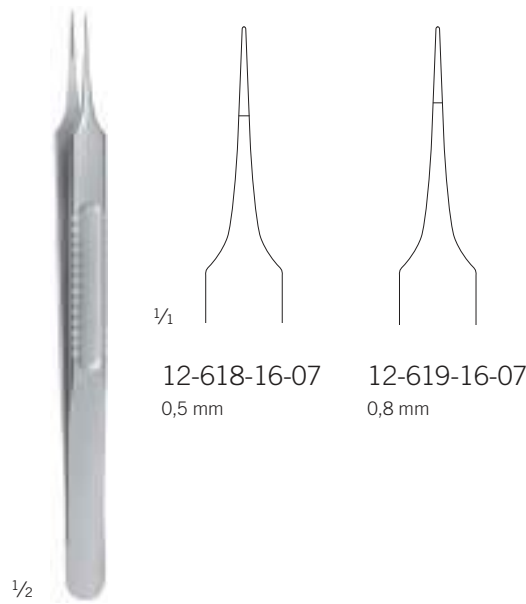

12-618-16-07
0,5 mm

12-619-16-07
0,8 mm

Lazar
12-618-16-07 -
12-619-16-07
15,5 cm / 6 1/8"

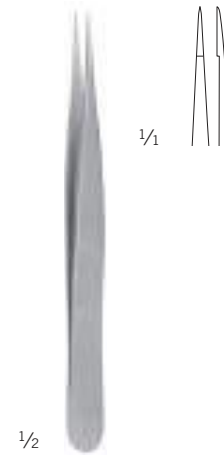

12-624-12-07

12 cm / 5 1/8"
0,3 mm



Austin
12-626-14-07

14 cm / 5 4/8"
0,8 mm

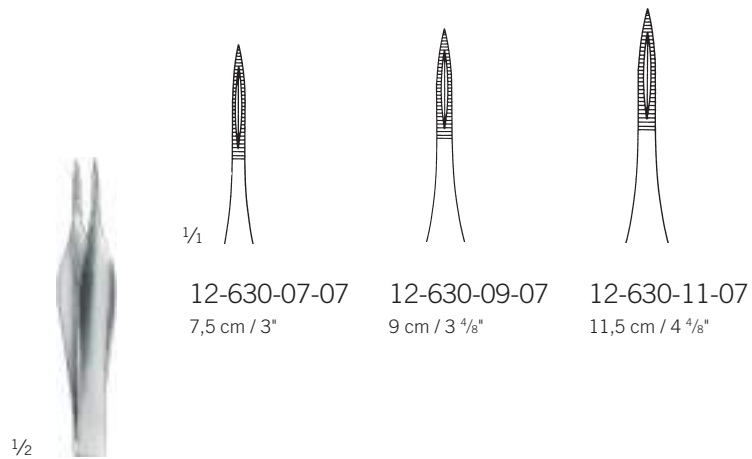

12-630-07-07
7,5 cm / 3"

12-630-09-07
9 cm / 3 4/8"

12-630-11-07
11,5 cm / 4 4/8"

Feilchenfeld
12-630-07-07 -
12-630-11-07

Splitterpinzetten, Mikroskopierpinzetten

Splinter Forceps, Microscopic Forceps

Pinzas para espinas, Pinzas para microscopías

Pinces à échardes, Pinces à microscopies

Pinze per scheggie, Pinze per microscopie



1/2



1/1

12-640-10-07
10,5 cm / 4 1/8"

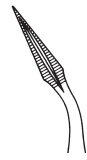

12-641-10-07
10,5 cm / 4 1/8"

Hunter
12-640-10-07 -
12-641-10-07



1/2



1/1

12-655-10-07
10 cm / 3 7/8"



1/2



1/1

12-656-10-07
10 cm / 3 7/8"



1/2



1/2

12-657-10-07
10 cm / 3 7/8"

Mikroskopierpinzette, superleicht, stumpf
Microscopic Forceps, super light, blunt
Pinza para microscopía, super ligero, roma
Pince à microscopie, très légère, mousse
Pinza per microscopia, molto leggera, smussa

12-659-10-07
10 cm / 3 7/8"

Mikroskopierpinzette, superleicht, spitz
Microscopic Forceps, super light, sharp
Pinza para microscopía, super ligero, puntiaguda
Pince à microscopie, très légère, pointue
Pinza per microscopia, molto leggera, appuntata



1/2



1/1

Shaaf
12-661-09-07
9,5 cm / 3 6/8"

Cilienpinzetten

Cilia Forceps
Pinzas depilatorias
Pincès à épiler les cils
Pinze depilatoria

Pinzetten

Forceps
Pinzas
Pincès
Pinze

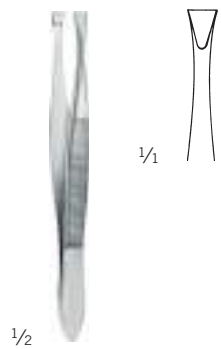
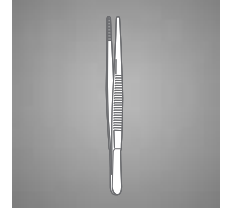

Littauer
12-664-08-07

8,5 cm / 3 3/8"

glattes Maul
smooth jaw
boca lisa
mors lisse
morso liscio

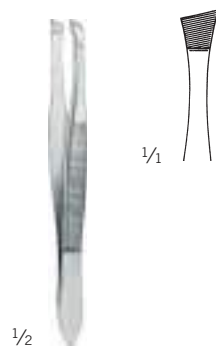

12-666-09-07

9 cm / 3 4/8"

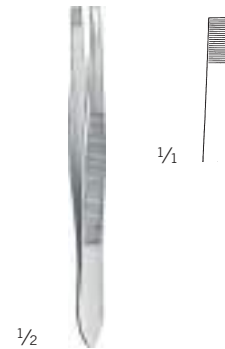

Douglas
12-674-09-07

9 cm / 3 4/8"

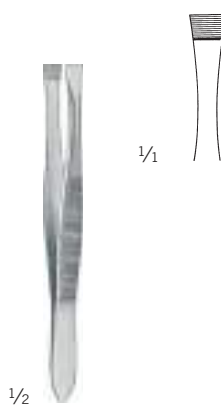

Douglas
12-676-09-07

9 cm / 3 4/8"

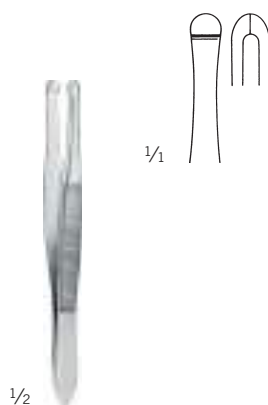

Beer
12-680-09-07

9 cm / 3 4/8"

glattes Maul
smooth jaw
boca lisa
mors lisse
morso liscio

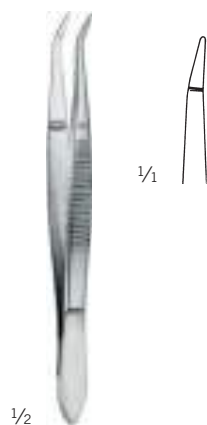

Barraquer
12-695-10-07

11 cm / 4 3/8"

glattes Maul
smooth jaw
boca lisa
mors lisse
morso liscio

Splitterzangen

Splinter Forceps
Pinzas para espinas
Pincers à échardes
Pinze per scheggie

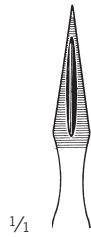

12-720-13-07
14 cm / 5 4/8"

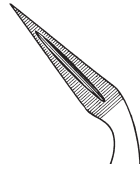

12-721-13-07
13,5 cm / 5 3/8"

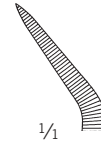

Peet
12-725-11-07
12,5 cm / 4 7/8"



12-740-15-07
15 cm / 5 7/8"

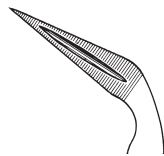

12-741-15-07
14 cm / 5 4/8"

Ralk
12-740-15-07 -
12-741-15-07

13

Arterienklemmen
Haemostatic Forceps
Pinzas hemostáticas
Pincès hémostatiques
Pinze emostatiche

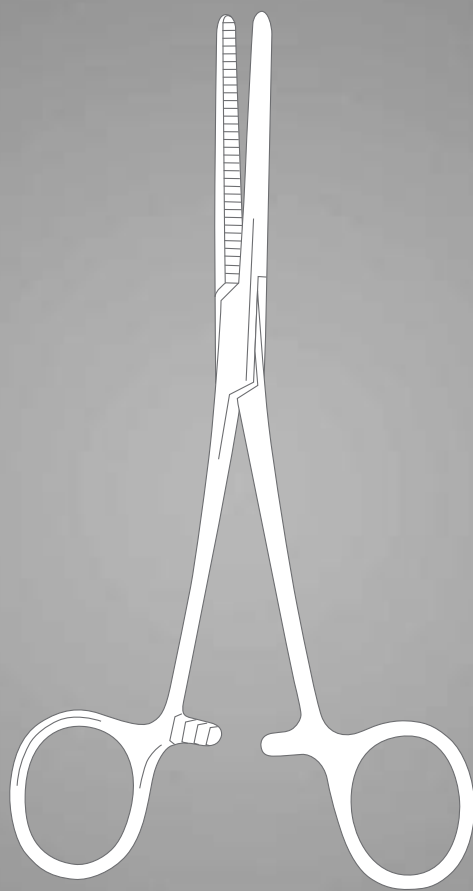

Clip-Anlegepinzette, Gefäßclips

Clip Applying Forceps, Vessel Clips

Pinzas para aplicar clips,

Pinces pour poser les clips vasculaires, Clips vasculaires

Pinze per applicazione clips vascolari,



Biemer
13-010-00-07
16 cm / 6 2/8"
Gefäßspreizer
Vascular spreader
Dilatador de vasos
Ecarteur vasculaire
Dilatatore vascolare



➔ 13-052-04-07 -
13-060-04-07

13-050-14-07
14,5 cm / 5 5/8"
ohne Sperre
w/o ratchet
sin cremallera
sans crémaillère
senza cremagliera



➔ 13-052-04-07 -
13-060-04-07

13-051-14-07
14,5 cm / 5 5/8"
mit Sperre
with ratchet
con cremallera
avec crémaillère
con cremagliera



Biemer
13-052-04-07 -
13-053-05-07



St	13-052-04-07	13-052-05-07	13-053-05-07
	14 mm	17 mm	17 mm
	4 mm	5 mm	5 mm
	4 mm	7 mm	7 mm
P	30 - 40 g	30 - 40 g	20 - 25 g

Gefäßclips, Approximatoren

Vessel Clips, Approximators
Clips vasculares, Aproximadores
Clips vasculaires, Approximateurs
Clip vascolari, Approssimatori

Arterienklemmen

Haemostatic Forceps
Pinzas hemostáticas
Pincas hémostatiques
Pinze emostatiche

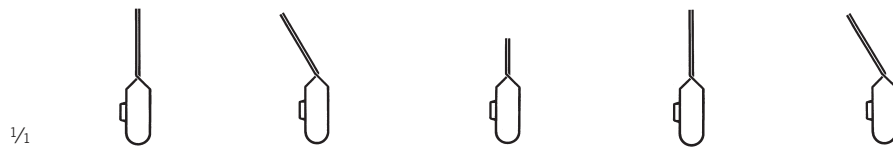

Biemer-Müller
13-054-05-07 -
13-059-05-07

	gerade, breit straight, wide recto, ancho droit, large retto, largo	gewinkelt, breit angled, wide angulado, ancho coudé, large angulato, largo	gerade, schmal straight, narrow recto, estrecho droit, étroit retto, stretto	gerade, schmal straight, narrow recto, estrecho droit, étroit retto, stretto	gewinkelt, schmal angled, narrow angulado, estrecho coudé, étroit angulato, stretto
St	13-054-05-07	13-055-05-07	13-056-03-07	13-058-05-07	13-059-05-07
	17 mm	17 mm	13 mm	17 mm	17 mm
	9 mm	9 mm	4,5 mm	9 mm	9 mm
	5 mm	5 mm	3 mm	5 mm	5 mm
P	25 - 30 g	25 - 30 g	25 - 30 g	25 - 30 g	25 - 30 g

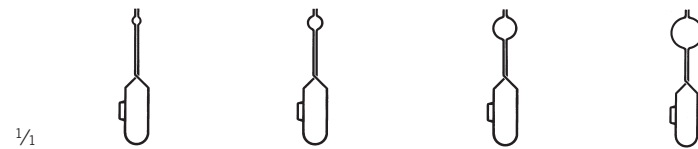

Müller
13-060-01-07 -
13-060-04-07

St	13-060-01-07	13-060-02-07	13-060-03-07	13-060-04-07
∅	1,5 mm	2,5 mm	3,0 mm	3,5 mm
	17 mm	17 mm	17 mm	17 mm
	9 mm	9 mm	9 mm	9 mm
	7 mm	7 mm	7 mm	7 mm
P	25 - 30 g	25 - 30 g	25 - 30 g	25 - 30 g

Approximatoren, Nerv-Approximatoren

Approximators, Nerve Approximators
 Aproximadores, Aproximadores para nervios
 Approximateurs, Approximateurs pour nerfs
 Approssimatori, Approssimatori per nervi

für Mikro-Gefäß Anastomosen in der Tiefe
 for Micro vessel anastomosis in the depth
 para micro anastomosis en la profundidad
 pour micro-anastomoses vasculaires en profondeur
 per micro-anastomosi vascolari nella profondità



1/1

13-062-00-07
 komplett mit Schlüssel
 complete with key
 completo con llave
 complet avec clef
 completti con chiave



1/1



1/1

13-062-01-07
 Schlüssel für Approximator
 Key for Approximator
 Llave para aproximador
 Clef pour approximateur
 Chiave per approssimatore



13-062-02-07 & 13-063-02-07



1/1

13-062-02-07
 Approximator, allein
 Approximator, only
 Aproximador, suelto
 Approximateur, seul
 Approssimatore, solo

Nadeln mit Schlüssel auswechselbar
 needles exchangeable by means of key
 agujas cambiables con llave
 aiguilles échangeable avec la clé
 aghi intercambiabili con una chiave



1/1

13-063-00-07
 komplett mit Schlüssel
 complete with key
 completo con llave
 complet avec clef
 completti con chiave



1/1



1/1

13-063-02-07
 Approximator mit Nadeln, allein
 Approximator with needles, only
 Aproximador con agujas, suelto
 Approximateur avec aiguille, seul
 Approssimatore con aghi, solo

13-063-04-07

Ersatznadeln, allein
 Spare Needles, only
 Agujas de repuesto, suelto
 Aiguilles de rechange, seul
 Aghi di ricambio, solo

Paar
 pair
 par
 paire
 paio



13-063-02-07

Mini-Gefäßclips, Clip-Anlegezangen, Bulldogklemmen

Mini Vessel Clips, Clip Applying Forceps

Mini Clips vasculares, Pinzas para aplicar clips

Micro-clips vasculaires, Pincès pour poser micro-clips

Mini-clip vascolari, Pinze per applicare clips vascolari

Arterienklemmen

Haemostatic Forceps

Pinzas hemostáticas

Pincès hémostatiques

Pinze emostatiche



1/2



13-102-04-07 -
13-102-10-07

13-104-14-07

14,5 cm / 5 5/8"

mit Sperre
with ratchet
con cremallera
avec crémaillère
con cremagliera



1/2



13-102-04-07 -
13-102-10-07

13-106-18-07

18,5 cm / 7 2/8"

mit Sperre
with ratchet
con cremallera
avec crémaillère
con cremagliera

1/1



1/1

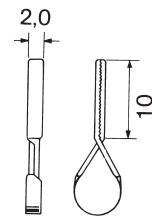
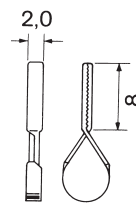
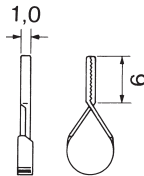
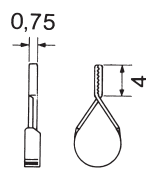

13-102-04-07 -
13-102-10-07

St	13-102-04-07	13-102-06-07	13-102-08-07	13-102-10-07
	13 mm	15 mm	17 mm	20 mm
	4 mm	6 mm	8 mm	10 mm
	4 mm	5 mm	6 mm	7 mm
	60 g	85 g	100 g	125 g

Bulldogklemmen

Bulldog Clamps
Clamps Bulldog
Clamps Bulldog
Pinze Bulldog

1/2



13-108-10-07 -
13-109-18-07

1/4

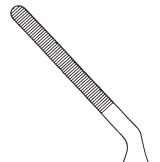
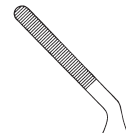
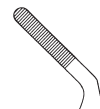

St	13-108-10-07	13-108-14-07	13-108-18-07	13-109-10-07	13-109-14-07	13-109-18-07
	31 mm	35 mm	39 mm	30 mm	33 mm	36 mm
	10 mm	14 mm	18 mm	10 mm	14 mm	18 mm
P	30 g	30 g	30 g	30 g	30 g	30 g

1/2



Dieffenbach
13-110-06-07 -
13-115-05-07

1/4

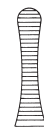
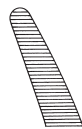

St	13-110-06-07	13-111-06-07	13-114-03-07	13-114-05-07	13-115-03-07	13-115-05-07
	6 cm / 2 3/8"	6 cm / 2 3/8"	3,5 cm / 1 3/8"	5 cm / 2"	3,5 cm / 1 3/8"	5 cm / 2"
	17 mm	17 mm	11 mm	15 mm	11 mm	15 mm

Bulldogklemmen

Bulldog Clamps
Clamps Bulldog
Clamps Bulldog
Pinze Bulldog

Arterienklemmen

Haemostatic Forceps
Pinzas hemostáticas
Pincas hémostatiques
Pinze emostatiche



1/2

Johns-Hopkins
13-115-38-07 -
13-115-90-07

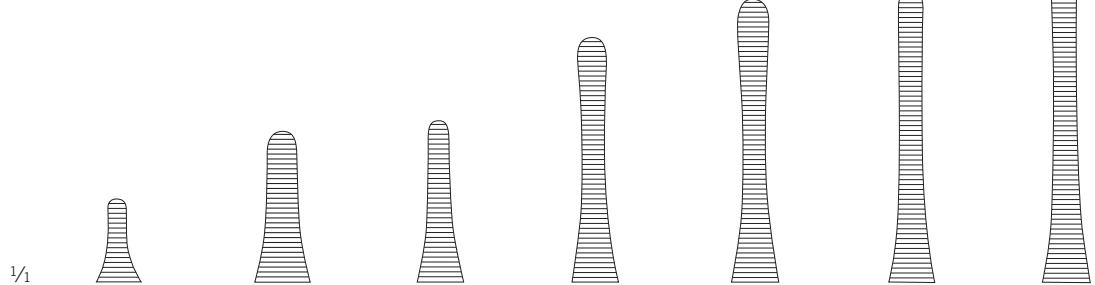

1/1

St	13-115-38-07	13-115-45-07	13-115-55-07	13-115-65-07	13-115-70-07	13-115-75-07	13-115-90-07
Ruler	3,8 cm / 1 3/8"	4,5 cm / 1 6/8"	5,5 cm / 2 1/8"	6,5 cm / 2 4/8"	7 cm / 2 4/8"	7,5 cm / 3"	9 cm / 3 4/8"
Ruler	12 mm	17 mm	25 mm	30 mm	35 mm	40 mm	50 mm



1/2

Johns-Hopkins
13-116-38-07 -
13-116-90-07

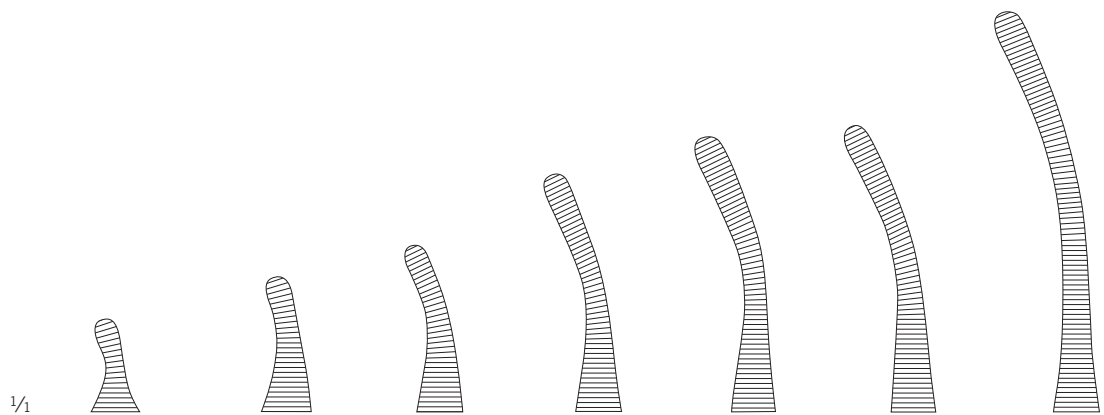

1/1

St	13-116-38-07	13-116-45-07	13-116-55-07	13-116-65-07	13-116-70-07	13-116-75-07	13-116-90-07
Ruler	3,8 cm / 1 4/8"	4,5 cm / 1 6/8"	5,5 cm / 2 1/8"	6,5 cm / 2 4/8"	7 cm / 2 6/8"	7,5 cm / 3"	9 cm / 3 4/8"
Ruler	12 mm	17 mm	25 mm	30 mm	35 mm	40 mm	50 mm

Bulldogklemmen

Bulldog Clamps
Clamps Bulldog
Clamps Bulldog
Pinze Bulldog



1/2

Diethrich
13-120-08-07 -
13-121-12-07

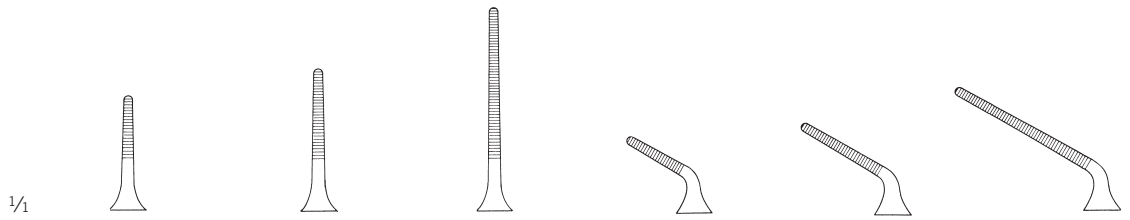

1/4

St	13-120-08-07	13-120-10-07	13-120-12-07	13-121-08-07	13-121-10-07	13-121-12-07
	45 mm	50 mm	60 mm	40 mm	45 mm	50 mm
	8 mm	12 mm	20 mm	8 mm	12 mm	20 mm
P	50 g	50 g	50 g	50 g	50 g	50 g

Atrauma

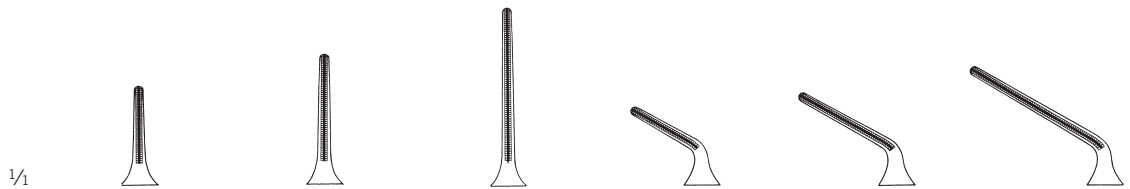

1/4

St	13-122-10-07	13-122-14-07	13-122-20-07	13-123-10-07	13-123-14-07	13-123-20-07
Ti	13-126-10-09	13-126-14-09	13-126-20-09	13-127-10-09	13-127-14-09	13-127-20-09
	45 mm	50 mm	60 mm	35 mm	45 mm	50 mm
	10 mm	14 mm	20 mm	10 mm	14 mm	20 mm
P	100 g	100 g	100 g	100 g	100 g	100 g



1/2

DeBakey-Diethrich
13-122-10-07 -
13-128-20-09

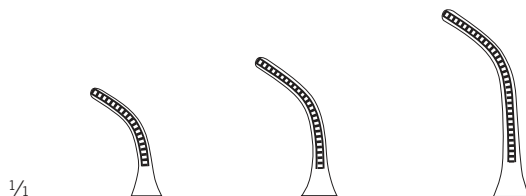

1/4

St	13-125-10-07	13-125-14-07	13-125-20-07
Ti	13-128-10-09	13-128-14-09	13-128-20-09
	35 mm	45 mm	50 mm
	10 mm	14 mm	20 mm
P	100 g	100 g	100 g

Bulldogklemmen

Bulldog Clamps
Clamps Bulldog
Clamps Bulldog
Pinze Bulldog

Arterienklemmen

Haemostatic Forceps
Pinzas hemostáticas
Pincas hémostatiques
Pinze emostatiche



1/1

Müller
13-124-11-07 -
13-124-20-07

1/1

St	13-124-11-07	13-124-12-07	13-124-13-07	13-124-14-07	13-124-15-07 *
	40 mm	40 mm	40 mm	40 mm	40 mm
	13 mm	13 mm	17 mm	13 mm	12 mm
	13 mm	13 mm	14 mm	13 mm	12 mm
P	50 g	50 g	50 g	50 g	50 g

St	13-124-16-07	13-124-17-07	13-124-18-07	13-124-19-07	13-124-20-07 *
	40 mm	40 mm	40 mm	40 mm	40 mm
	13 mm	13 mm	17 mm	13 mm	12 mm
	13 mm	13 mm	14 mm	13 mm	12 mm
P	80 g	80 g	80 g	80 g	80 g

* kniegebogen
knee-bent
acodado tipo rodilla
genouillé
a ginocchiera

Atrauma



1/2

13-124-25-07 -
13-124-32-07

1/1

St	13-124-25-07	13-124-26-07	13-124-27-07	13-124-28-07
	95 mm	120 mm	110 mm	105 mm
	38 mm	65 mm	60 mm	50 mm
P	250 g	250 g	250 g	250 g

St	13-124-29-07	13-124-30-07	13-124-31-07	13-124-32-07
	95 mm	120 mm	110 mm	105 mm
	38 mm	65 mm	60 mm	50 mm
P	350 g	350 g	350 g	350 g

13

Bulldogklemmen

Bulldog Clamps
Clamps Bulldog
Clamps Bulldog
Pinze Bulldog

Atrauma

1/1



1/1

Mini-Glover
13-132-30-09 -
13-142-50-09

Vena				
Ti	13-132-30-09	13-132-35-09	13-132-40-09	13-132-50-09
	30 mm	35 mm	40 mm	50 mm
	9 mm	13 mm	14 mm	23 mm
P	110 +/- 10 g	110 +/- 10 g	110 +/- 10 g	110 +/- 10 g

Arteria				
Ti	13-142-30-09	13-142-35-09	13-142-40-09	13-142-50-09
	30 mm	35 mm	40 mm	50 mm
	9 mm	13 mm	14 mm	23 mm
P	220 +/- 10 g	220 +/- 10 g	220 +/- 10 g	220 +/- 10 g

Atrauma

1/1



1/1

Mini-Glover
13-133-30-09 -
13-143-50-09

Vena				
Ti	13-133-30-09	13-133-35-09	13-133-40-09	13-133-50-09
	30 mm	35 mm	40 mm	50 mm
	9 mm	13 mm	14 mm	23 mm
P	110 +/- 10 g	110 +/- 10 g	110 +/- 10 g	110 +/- 10 g

Arteria				
Ti	13-143-30-09	13-143-35-09	13-143-40-09	13-143-50-09
	30 mm	35 mm	40 mm	50 mm
	9 mm	13 mm	14 mm	23 mm
P	220 +/- 10 g	220 +/- 10 g	220 +/- 10 g	220 +/- 10 g

Bulldogklemmen

Bulldog Clamps
Clamps Bulldog
Clamps Bulldog
Pinze Bulldog

Arterienklemmen

Haemostatic Forceps
Pinzas hemostáticas
Pincas hémostatiques
Pinze emostatiche



Atrauma

1/1



Vena				
Ti	13-135-30-09	13-135-35-09	13-135-40-09	13-135-50-09
	30 mm	35 mm	40 mm	50 mm
	9 mm	13 mm	14 mm	23 mm
P	110 +/- 10 g	110 +/- 10 g	110 +/- 10 g	110 +/- 10 g



1/1

Mini-Glover
13-135-30-09 -
13-145-50-09

Arteria				
Ti	13-145-30-09	13-145-35-09	13-145-40-09	13-145-50-09
	30 mm	35 mm	40 mm	50 mm
	9 mm	13 mm	14 mm	23 mm
P	220 +/- 10 g	220 +/- 10 g	220 +/- 10 g	220 +/- 10 g

13



1/2

Mini-Glover
13-131-24-07

24 cm / 9 4/8"

Anlegezange für Bulldogklemmen, Mini-Glover
Applying Forceps for Bulldog clamps, Mini-Glover
Pinza aplicadora para clamps bulldog, Mini-Glover
Pince pour poser les clamps Bulldog, Mini-Glover
Pinza per posizionare le pinze Bulldog, Mini-Glover

13-132-30-09 -
13-145-50-09

Arterienklemmen

Haemostatic Forceps
 Pinzas hemostáticas
 Pinces hémostatiques
 Pinze emostatiche



1/2

Pean
 13-176-14-07 -
 13-176-16-07

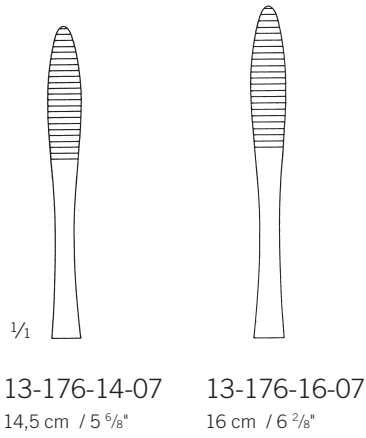

13-176-14-07
 14,5 cm / 5 5/8"

13-176-16-07
 16 cm / 6 2/8"



1/2

Spencer-Wells
 13-248-13-07 -
 13-249-20-07

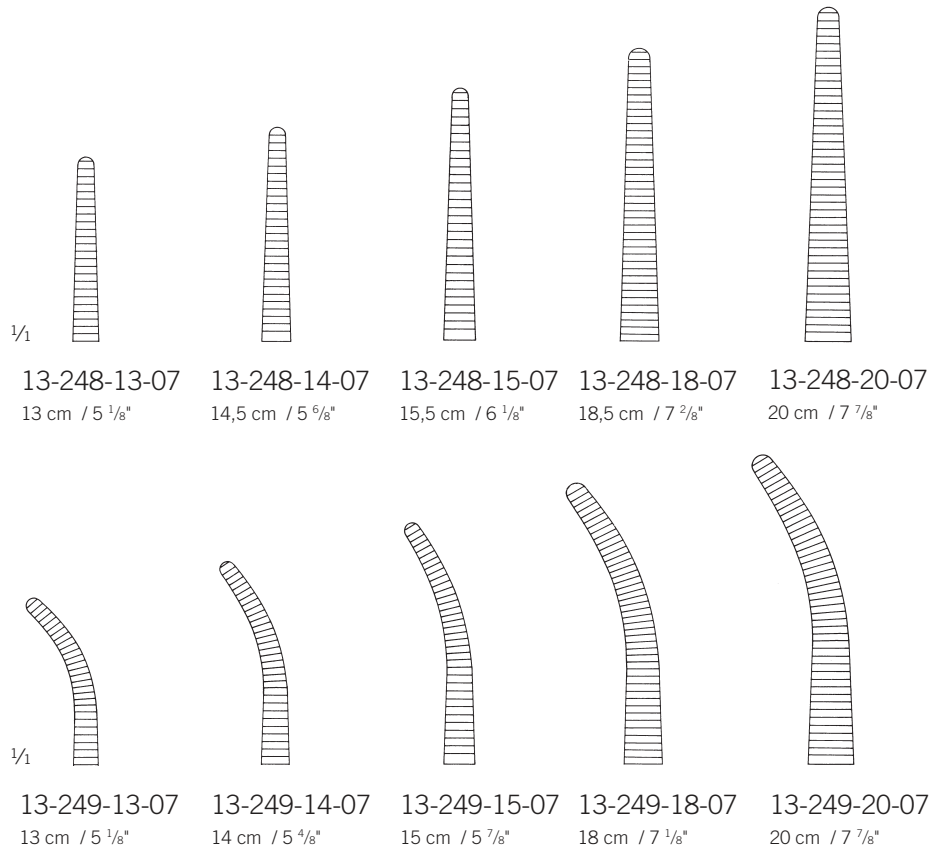

1/1

13-248-13-07
 13 cm / 5 1/8"

13-248-14-07
 14,5 cm / 5 6/8"

13-248-15-07
 15,5 cm / 6 1/8"

13-248-18-07
 18,5 cm / 7 2/8"

13-248-20-07
 20 cm / 7 7/8"

1/1

13-249-13-07
 13 cm / 5 1/8"

13-249-14-07
 14 cm / 5 4/8"

13-249-15-07
 15 cm / 5 7/8"

13-249-18-07
 18 cm / 7 1/8"

13-249-20-07
 20 cm / 7 7/8"

Arterienklemmen, Organfasszangen

Haemostatic Forceps, Organ Grasping Forceps
 Pinzas hemostáticas, Pinzas para sacar órganos
 Pincès hémostatiques, Pincès pour saisir organes
 Pinze emostatiche, Pinze per afferrare organi

Arterienklemmen

Haemostatic Forceps
 Pinzas hemostáticas
 Pincès hémostatiques
 Pinze emostatiche

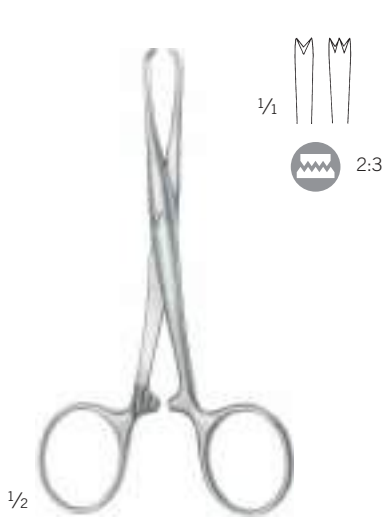

Chaput
 13-256-13-07
 12,5 cm / 4 7/8"



Tuffier
 13-258-13-07
 12,5 cm / 4 7/8"

Atrauma



13-266-25-07
 25 cm / 9 7/8"

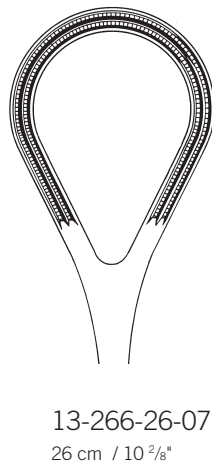

13-266-26-07
 26 cm / 10 2/8"

13-266-25-07 -
 13-266-26-07

Organfasszangen

Organ Grasping Forceps
 Pinzas para sacar órganos
 Pincers pour saisir organes
 Pinze per afferrare organi

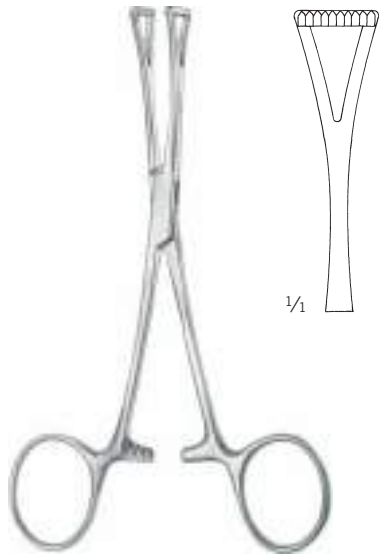

Collin
 13-268-14-07
 14 cm / 5 4/8"

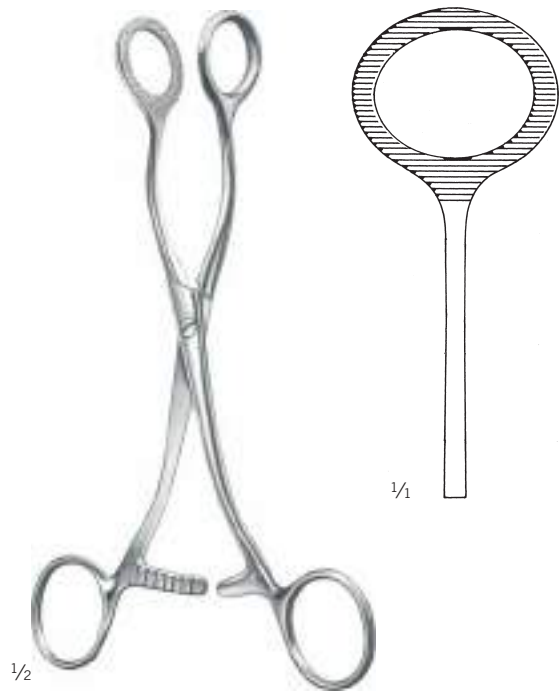

Collin
 13-278-17-07
 17 cm / 6 5/8"
 Tumorfasszange
 Tumor Grasping Forceps
 Pinzas para sacar órganos
 Pincers à tumeurs à vis
 Pinze per afferrare tumori



Pennington
 13-280-15-07 -
 13-280-20-07

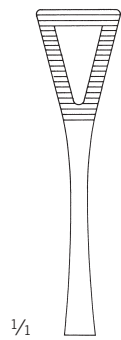

13-280-15-07
 15,5 cm / 6 1/8"

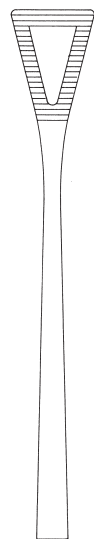

13-280-20-07
 21 cm / 8 2/8"

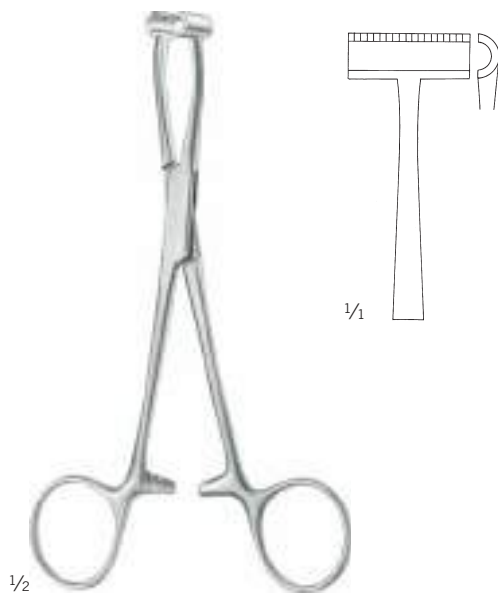

Pratt
 13-282-15-07
 15 cm / 5 7/8"

Arterienklemmen, Präparierklemmen

Haemostatic Forceps, Dissecting and Ligature Forceps

Pinzas hemostáticas, Pinzas para preparación y ligadura

Pinces hémostatiques, Pincès à dissecquer et à ligatures

Pinze emostatiche, Pinze per preparazioni e legature

Arterienklemmen

Haemostatic Forceps

Pinzas hemostáticas

Pinces hémostatiques

Pinze emostatiche

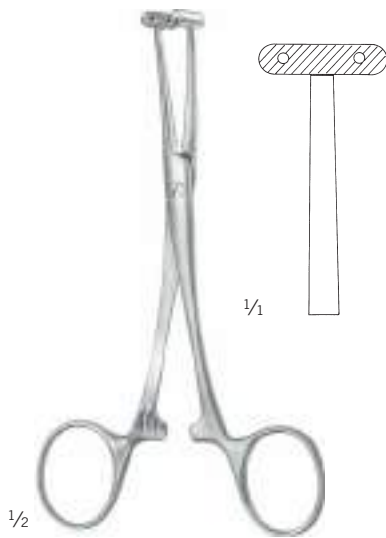

Martel-Rees
13-290-14-07

13,5 cm / 5 3/8"
Face-lift-Klemme
Face-lift Forceps
Pinza para Face-lift
Pincès pour Face-lift
Pinze per Face-lift

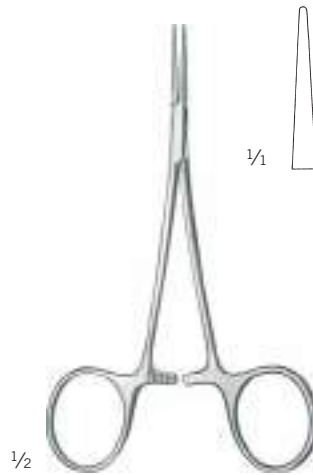

13-302-12-07

12,5 cm / 4 7/8"
Fadenklemme, glattes Maul
Ligature Forceps, smooth jaw
Pinza para hilos, boca lisa
Pince à ligatures, mors lisse
Pinza per legature, morso liscio



Mixer-Baby
13-303-01-07 -
13-303-02-07

1/1

13-303-01-07
13,5 cm / 5 3/8"

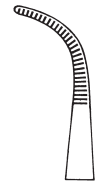

13-303-02-07
13 cm / 5 1/8"



Mikro-Adson
13-304-14-07

14 cm / 5 4/8"



Baby-Adson
13-305-18-07

18 cm / 7 1/8"

Arterienklemmen

Haemostatic Forceps
 Pinzas hemostáticas
 Pinces hémostatiques
 Pinze emostatiche

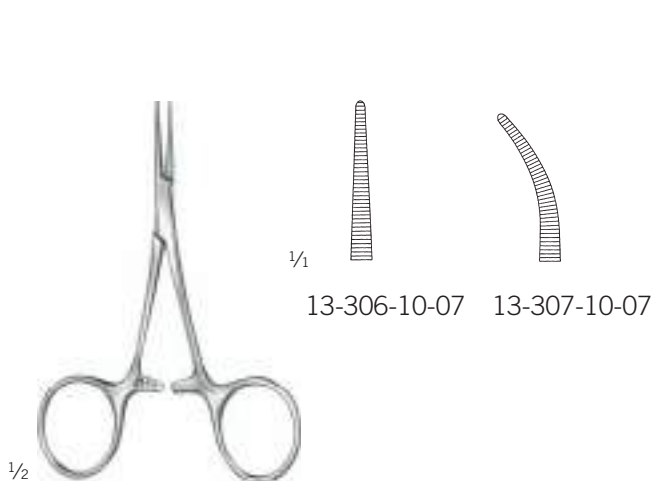

Hartmann
 13-306-10-07 -
 13-307-10-07
 10 cm / 3 7/8"



13-309-12-07
 12 cm / 4 5/8"
 Fadenklemme
 Ligature Forceps
 Pinza para hilos
 Pince à ligatures
 Pinza per legature

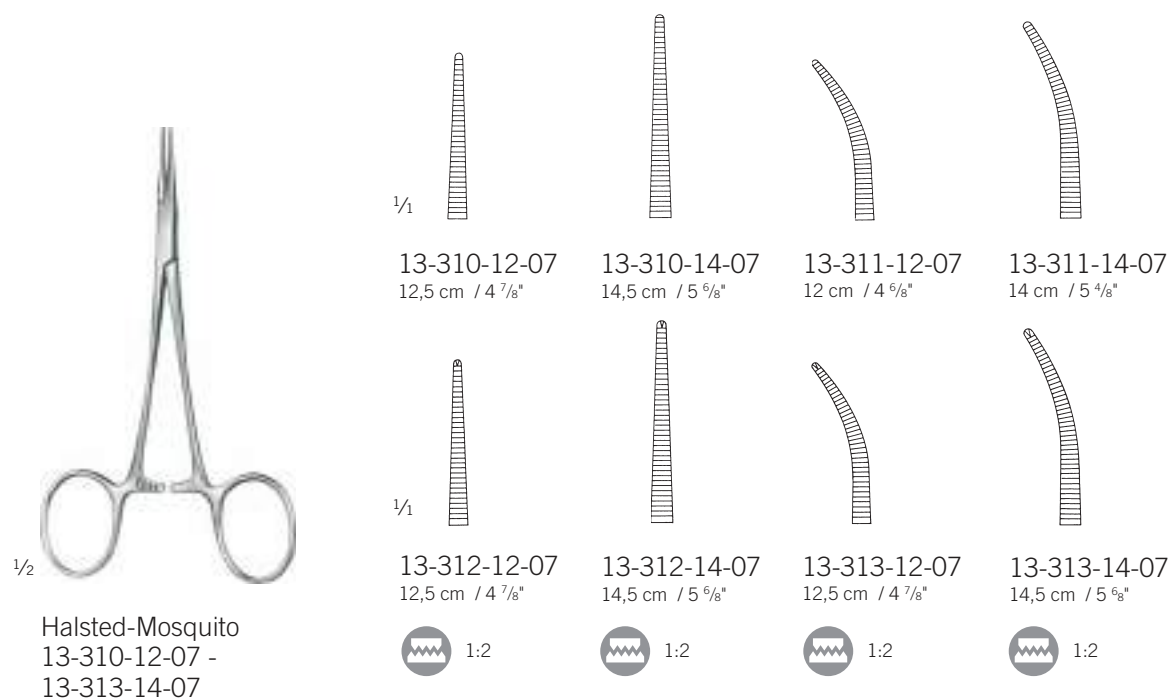

Halsted-Mosquito
 13-310-12-07 -
 13-313-14-07

Arterienklemmen

Haemostatic Forceps
Pinzas hemostáticas
Pincès hémostatiques
Pinze emostatiche

Arterienklemmen

Haemostatic Forceps
Pinzas hemostáticas
Pincès hémostatiques
Pinze emostatiche



Ti



1/2

Halsted-Mosquito
13-310-62-09 -
13-313-62-09

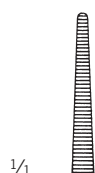

13-310-62-09
12,5 cm / 4 7/8"



13-311-62-09
12 cm / 4 6/8"



13-312-62-09
12 cm / 4 6/8"



13-313-62-09
12 cm / 4 6/8"



13



1/2

Halsted-Mosquito
13-316-18-07 -
13-319-21-07

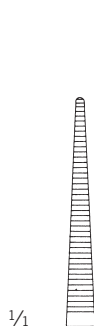

13-316-18-07
18,5 cm / 7 2/8"



13-316-21-07
21 cm / 8 2/8"

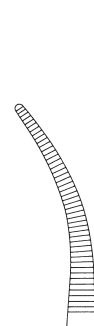

13-317-18-07
18 cm / 7 1/8"



13-317-21-07
20,5 cm / 8 1/8"

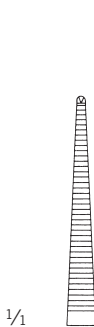

13-318-18-07
18,5 cm / 7 2/8"



13-318-21-07
21 cm / 8 2/8"

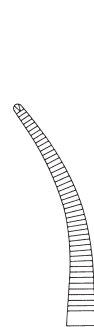

13-319-18-07
18 cm / 7 1/8"



13-319-21-07
20,5 cm / 8 1/8"



Arterienklemmen

Haemostatic Forceps
Pinzas hemostáticas
Pinces hémostatiques
Pinze emostatiche



Mikro-Mosquito
13-320-10-07 -
13-323-12-07

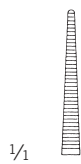

13-320-10-07
10 cm / 3 7/8"



13-320-12-07
12 cm / 4 5/8"



13-321-10-07
10 cm / 3 7/8"



13-321-12-07
12 cm / 4 5/8"

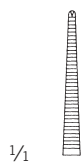

13-322-10-07
10 cm / 3 7/8"



13-322-12-07
12 cm / 4 5/8"



13-323-10-07
10 cm / 3 7/8"



13-323-12-07
12 cm / 4 5/8"



Providence-Hospital
13-324-14-07 -
13-325-14-07

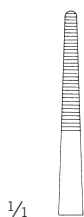

13-324-14-07
14 cm / 5 4/8"

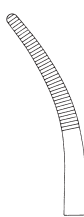

13-325-14-07
13,5 cm / 5 3/8"



Leriche
13-326-15-07 -
13-329-15-07



13-326-15-07
15,5 cm / 6 1/8"



13-327-15-07
15 cm / 5 7/8"



13-328-15-07
15,5 cm / 6 1/8"

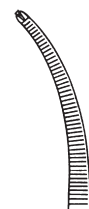

13-329-15-07
15 cm / 5 7/8"



Arterienklemmen

Haemostatic Forceps
Pinzas hemostáticas
Pincès hémostatiques
Pinze emostatiche

Arterienklemmen

Haemostatic Forceps
Pinzas hemostáticas
Pincès hémostatiques
Pinze emostatiche

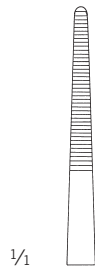

1/4

13-330-14-07
14,5 cm / 5 7/8"



13-330-64-09
14,5 cm / 5 7/8"



13-331-14-07
14 cm / 5 4/8"



13-331-64-09
14 cm / 5 4/8"



1/2

Kelly
13-330-14-07 -
13-331-64-09

13

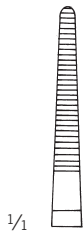

1/4

Dunhill
13-332-12-07
12,5 cm / 4 7/8"

1/2

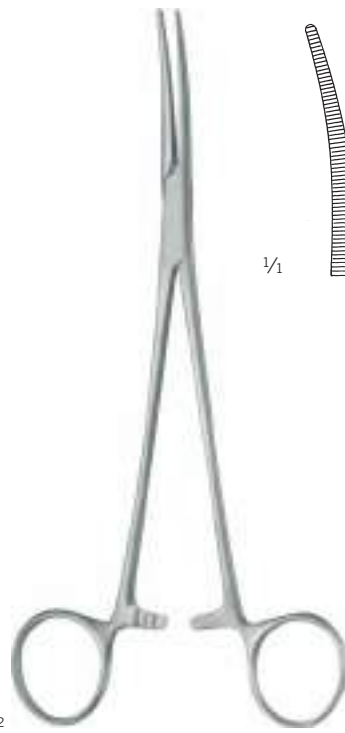

1/4

Dunhill
13-333-19-07
18,5 cm / 7 2/8"

1/2

Arterienklemmen, Präparierklemmen

Haemostatic Forceps, Dissecting and Ligature Forceps

Pinzas hemostáticas, Pinzas para preparación y ligadura

Pinces hémostatiques, Pinces à dissecquer et à ligatures

Pinze emostatiche, Pinze per preparazioni e legature



Kelly-Rankin
13-334-16-07 -
13-335-16-07
16 cm / 6 2/8"

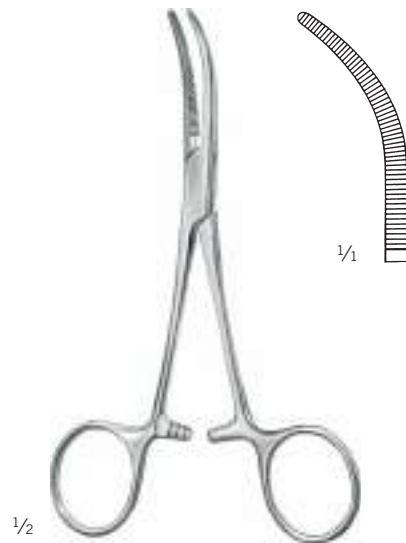

Overholt-Baby
13-339-14-07
13,5 cm / 5 3/8"

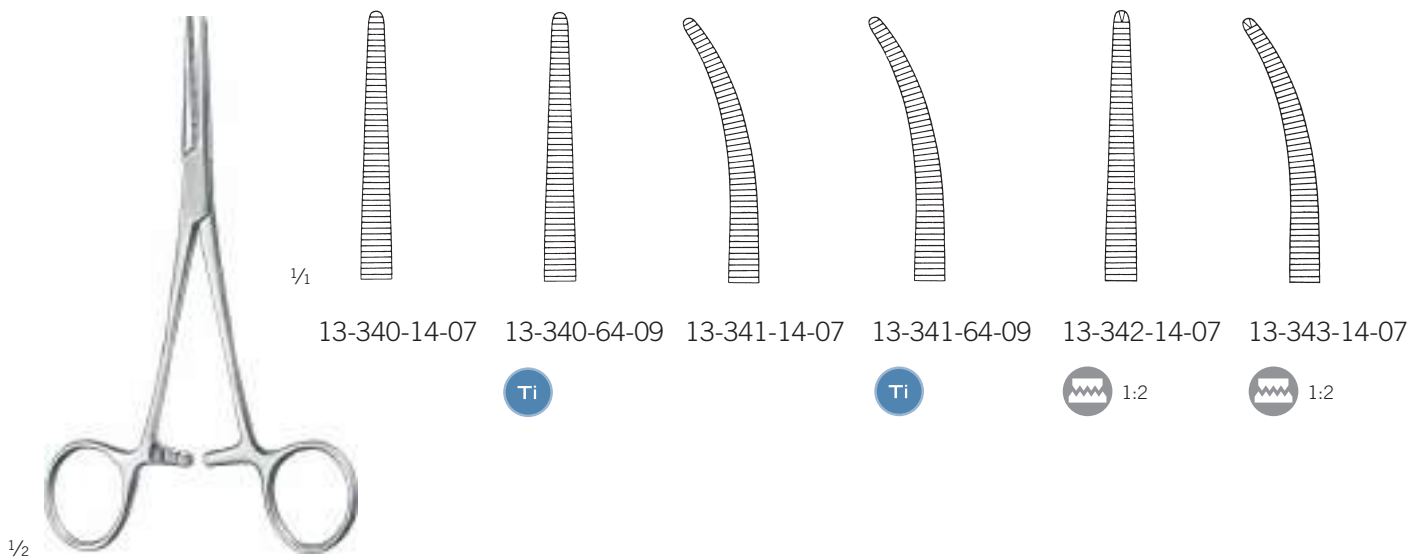

Crile
13-340-14-07 -
13-343-14-07
14,5 cm / 5 6/8"

Arterienklemmen

Haemostatic Forceps
Pinzas hemostáticas
Pincès hémostatiques
Pinze emostatiche

Arterienklemmen

Haemostatic Forceps
Pinzas hemostáticas
Pincès hémostatiques
Pinze emostatiche



1/2

13-346-16-07

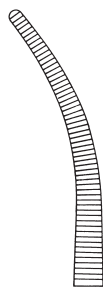

13-347-16-07

Crile-Rankin
13-346-16-07 -
13-347-16-07
16 cm / 6 2/8"



1/2

13-348-15-07



13-350-15-07



Lovelace
13-348-15-07 -
13-350-15-07
16 cm / 6 2/8"

kreuzgerieftes Maul
cross serrated jaw
boca estriada en forma de cruz
mors à rainures croisées
morso con striatura cruciforme



1/2

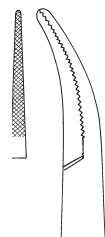

Dandy-Mosquito
13-351-12-07
12 cm / 4 6/8"

seitlich gebogen
laterally curved
curva lateralmente
courbe lateralement
curva laterale



1/2

13-355-14-07
14,5 cm / 5 6/8"

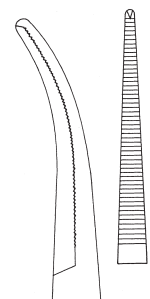

13-357-14-07
14 cm / 5 4/8"



Dandy
13-355-14-07 -
13-357-14-07

seitlich gebogen
laterally curved
curva lateralmente
courbe lateralement
curva laterale

13

Arterienklemmen, Präparierklemmen

Haemostatic Forceps, Dissecting and Ligature Forceps
 Pinzas hemostáticas, Pinzas para preparación y ligadura
 Pincas hémostatiques, Pincas à dissecquer et à ligatures
 Pinze emostatiche, Pinze per preparazioni e legature



1/1

13-363-18-07
18,5 cm / 7 2/8"



13-363-19-07
19 cm / 7 4/8"



1/1

13-364-18-07
19 cm / 7 4/8"

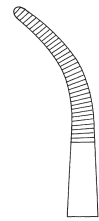

13-365-18-07
18,5 cm / 7 2/8"

Schnidt
13-363-18-07 -
13-363-19-07

Adson
13-364-18-07 -
13-365-18-07



1/1

Martin-Fuchsig
13-369-20-07
20,5 cm / 8 1/8"



1/1

Rochester-Carmalt
13-370-16-07 -
13-371-20-07

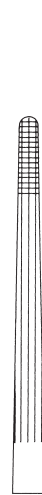

13-370-16-07
17 cm / 6 6/8"



13-370-20-07
20,5 cm / 8 1/8"



13-371-16-07
16,5 cm / 6 4/8"

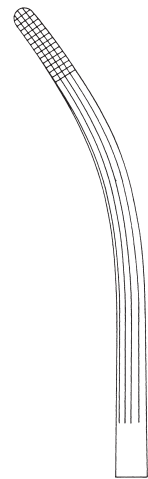

13-371-20-07
20 cm / 7 7/8"

Arterienklemmen

Haemostatic Forceps
Pinzas hemostáticas
Pincès hémostatiques
Pinze emostatiche

Arterienklemmen

Haemostatic Forceps
Pinzas hemostáticas
Pincès hémostatiques
Pinze emostatiche



1/2

1/1						
	13-374-13-07	13-374-14-07	13-374-16-07	13-375-13-07	13-375-14-07	13-375-16-07
	13,5 cm / 5 3/8"	14,5 cm / 5 6/8"	17 cm / 6 6/8"	13 cm / 5 1/8"	14 cm / 5 4/8"	16,5 cm / 6 4/8"

Pean

13-374-13-07 -
13-375-16-07

13



1/2

1/1						
	13-380-14-07	13-380-16-07	13-380-18-07	13-381-14-07	13-381-16-07	13-381-18-07
	14,5 cm / 5 6/8"	16,5 cm / 6 4/8"	18,5 cm / 7 2/8"	14 cm / 5 4/8"	16 cm / 6 2/8"	18 cm / 7 1/8"

Pean-Nippon

13-380-14-07 -
13-381-18-07

Arterienklemmen

Haemostatic Forceps
Pinzas hemostáticas
Pinces hémostatiques
Pinze emostatiche



1/2

Kocher-Nippon
13-382-14-07 -
13-383-18-07

13-382-14-07 14,5 cm / 5 7/8"	13-382-16-07 16,5 cm / 6 4/8"	13-382-18-07 18,5 cm / 7 2/8"	13-383-14-07 14 cm / 5 4/8"	13-383-16-07 16 cm / 6 2/8"	13-383-18-07 18 cm / 7 1/8"
1:2	1:2	1:2	1:2	1:2	1:2



1/2

Kocher
13-384-13-07 -
13-385-16-07

13-384-13-07 13 cm / 5 1/8"	13-384-14-07 14 cm / 5 4/8"	13-384-16-07 16 cm / 6 2/8"	13-385-13-07 13 cm / 5 1/8"	13-385-14-07 14 cm / 5 4/8"	13-385-16-07 16 cm / 6 2/8"
1:2	1:2	1:2	1:2	1:2	1:2

Arterienklemmen

Haemostatic Forceps
Pinzas hemostáticas
Pincès hémostatiques
Pinze emostatiche

Arterienklemmen

Haemostatic Forceps
Pinzas hemostáticas
Pincès hémostatiques
Pinze emostatiche

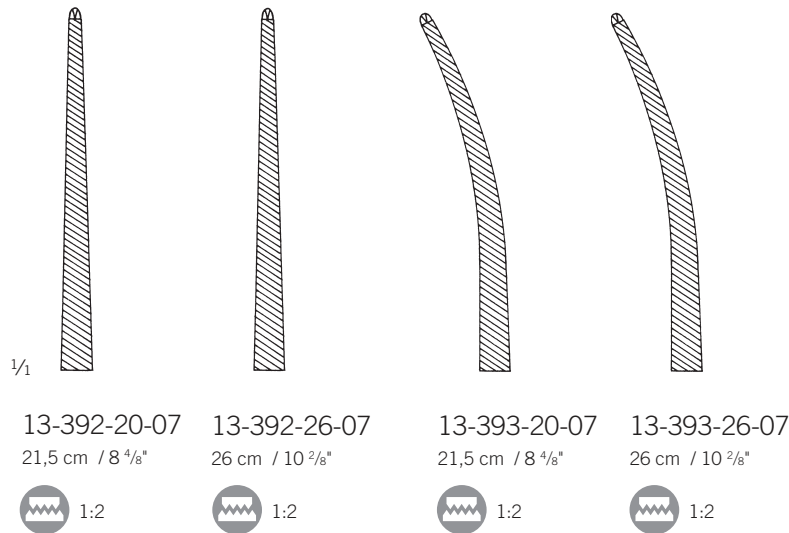
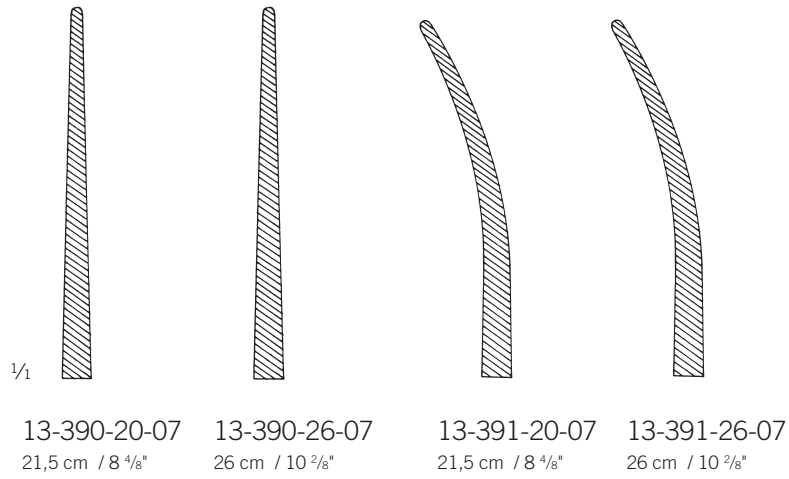

Bengolea
13-390-20-07 -
13-393-26-07

Arterienklemmen

Haemostatic Forceps
 Pinzas hemostáticas
 Pinces hémostatiques
 Pinze emostatiche

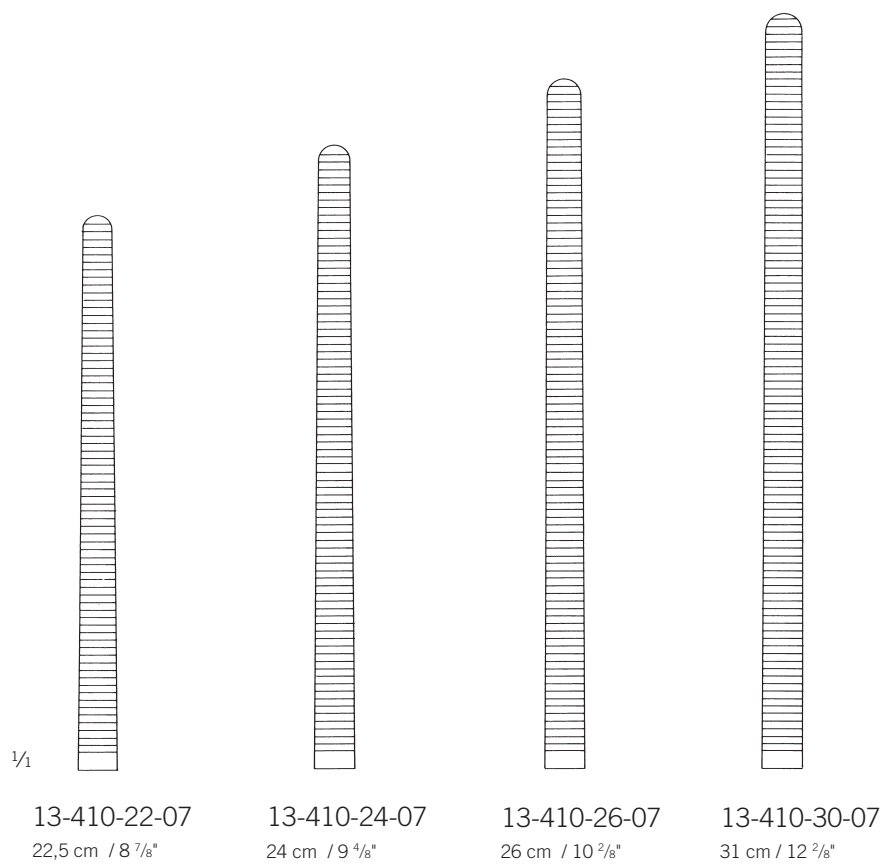
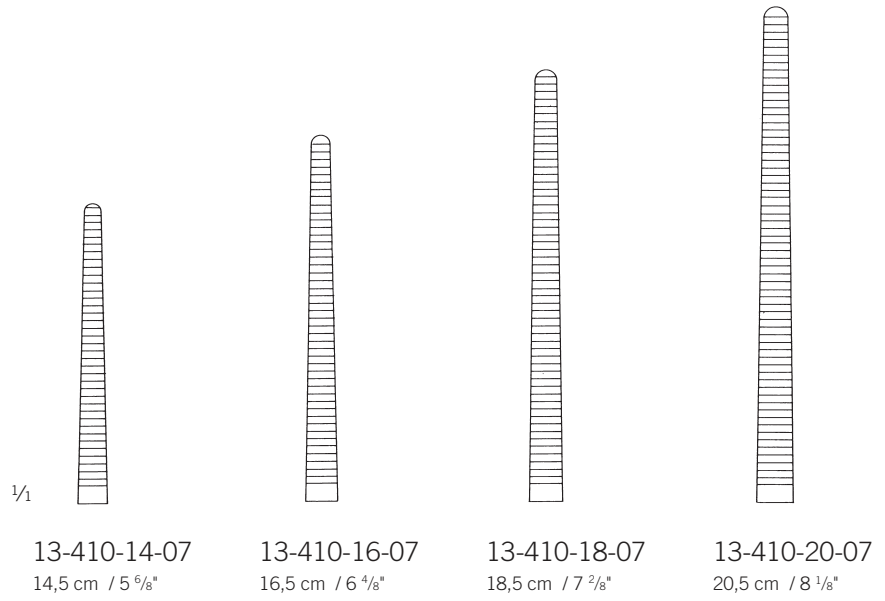

Pean (Rochester)
 13-410-14-07 -
 13-410-30-07

Arterienklemmen

Haemostatic Forceps
Pinzas hemostáticas
Pincès hémostatiques
Pinze emostatiche

Arterienklemmen

Haemostatic Forceps
Pinzas hemostáticas
Pincès hémostatiques
Pinze emostatiche



13

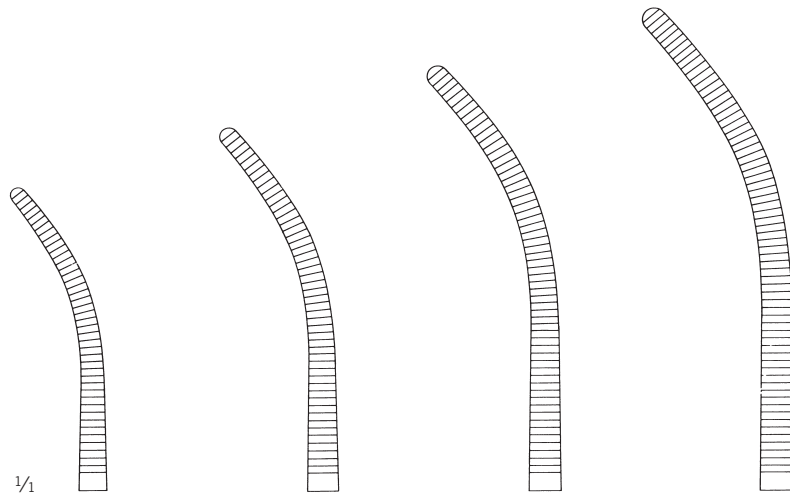

1/1

13-411-14-07
14 cm / 5 4/8"

13-411-16-07
16,5 cm / 6 4/8"

13-411-18-07
18,5 cm / 7 2/8"

13-411-20-07
20,5 cm / 8 1/8"



1/2

Pean (Rochester)
13-411-14-07 -
13-411-30-07

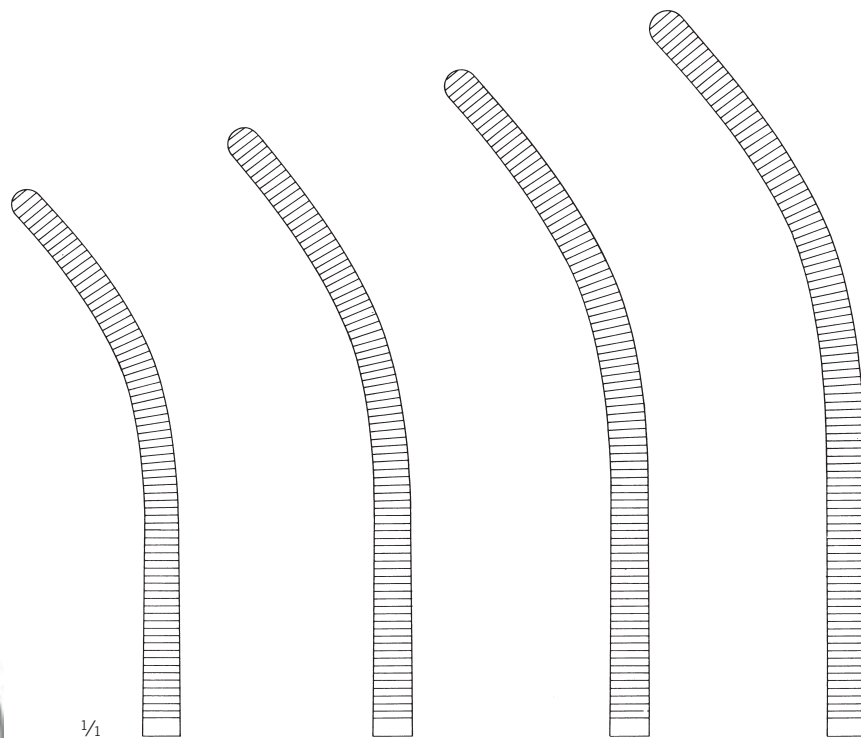

1/1

13-411-22-07
22 cm / 8 5/8"

13-411-24-07
24 cm / 9 4/8"

13-411-26-07
26 cm / 10 2/8"

13-411-30-07
30,5 cm / 12"

Arterienklemmen

Haemostatic Forceps
 Pinzas hemostáticas
 Pinces hémostatiques
 Pinze emostatiche

1/1			
13-414-14-07 14,5 cm / 5 7/8"	13-414-16-07 16,5 cm / 6 4/8"	13-414-18-07 18,5 cm / 7 3/8"	13-414-20-07 20,5 cm / 8 1/8"
1:2	1:2	1:2	1:2



1/2

Kocher (Ochsner)
 13-414-14-07 -
 13-414-30-07

1/1			
13-414-22-07 22,5 cm / 8 7/8"	13-414-24-07 24 cm / 9 4/8"	13-414-26-07 26 cm / 10 2/8"	13-414-30-07 31 cm / 12 2/8"
1:2	1:2	1:2	1:2

Arterienklemmen

Haemostatic Forceps
Pinzas hemostáticas
Pincès hémostatiques
Pinze emostatiche

Arterienklemmen

Haemostatic Forceps
Pinzas hemostáticas
Pincès hémostatiques
Pinze emostatiche



13

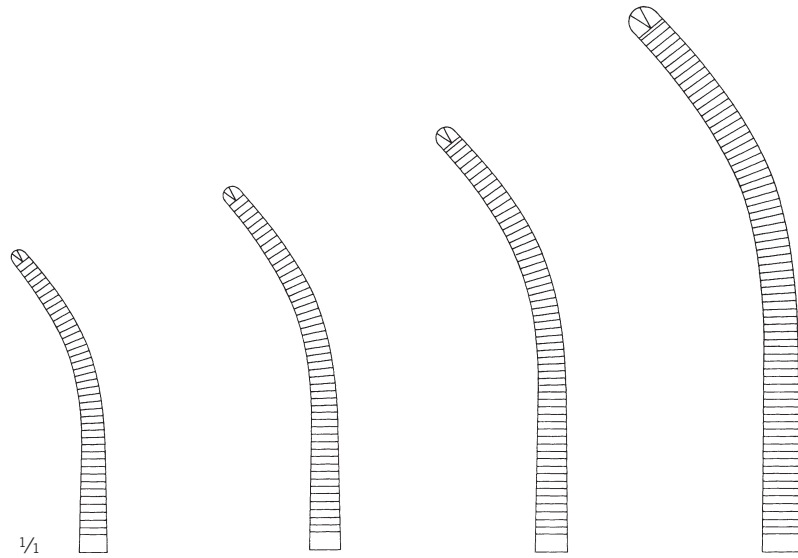

1/1

13-415-14-07
14 cm / 5 4/8"



13-415-16-07
16,5 cm / 6 4/8"



13-415-18-07
18,5 cm / 7 2/8"



13-415-20-07
20 cm / 7 7/8"



1/2

Kocher (Ochsner)
13-415-14-07 -
13-415-30-07

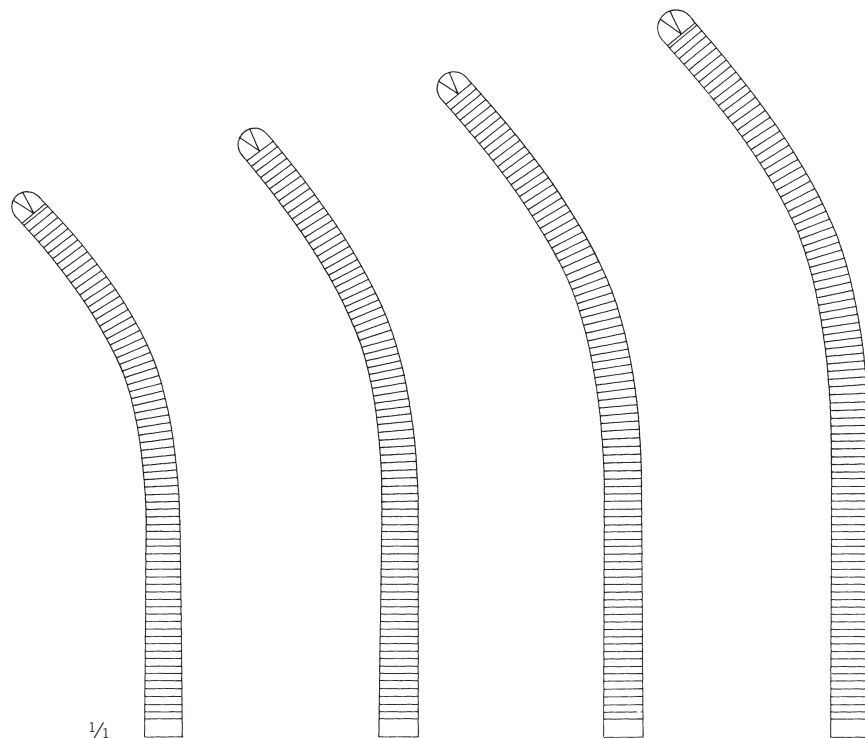

1/1

13-415-22-07
22,5 cm / 8 7/8"



13-415-24-07
24 cm / 9 4/8"



13-415-26-07
26 cm / 10 2/8"



13-415-30-07
30,5 cm / 12"



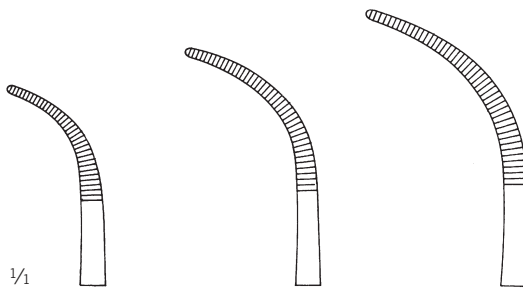

Fig. 1
 13-417-01-07
 18,5 cm / 7 2/8"

Fig. 2
 13-417-02-07
 20,5 cm / 8 1/8"

Fig. 3
 13-417-03-07
 21cm / 8 2/8"

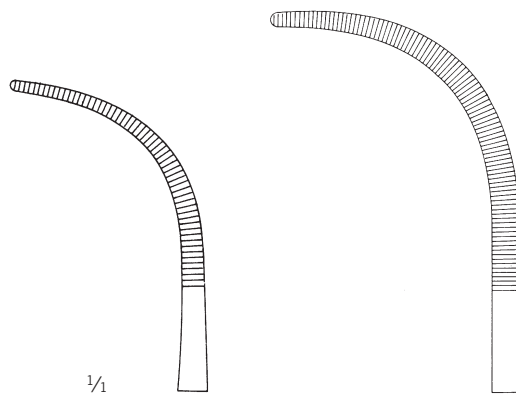

Fig. 4
 13-417-04-07
 21,5 cm / 8 2/8"

Fig. 5
 13-417-05-07
 24,5 cm / 9 6/8"



Overholt-Martin
 13-417-01-07 -
 13-417-05-07

Präparierklemmen

Dissecting and Ligature Forceps
 Pinzas para preparación y ligadura
 Pincès à disséquer et à ligatures
 Pinze per preparazioni e legature

Arterienklemmen

Haemostatic Forceps
 Pinzas hemostáticas
 Pincès hémostatiques
 Pinze emostatiche



Mixer-Baby
 13-419-18-07
 18,5 cm / 7 2/8"



Adson-Baby
 13-421-14-07 -
 13-421-18-07

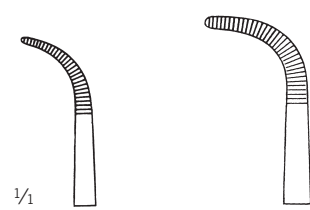

13-421-14-07
 14,5 cm / 5 5/8"

13-421-18-07
 18 cm / 7 1/8"



Heiss
 13-422-20-07 -
 13-425-20-07

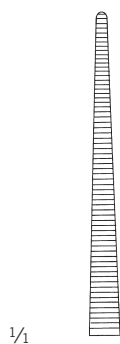

13-422-20-07
 21 cm / 8 2/8"

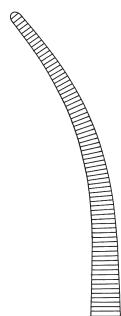

13-423-20-07
 20,5 cm / 8 1/8"

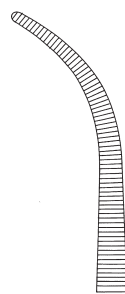

13-425-20-07
 21 cm / 8 2/8"

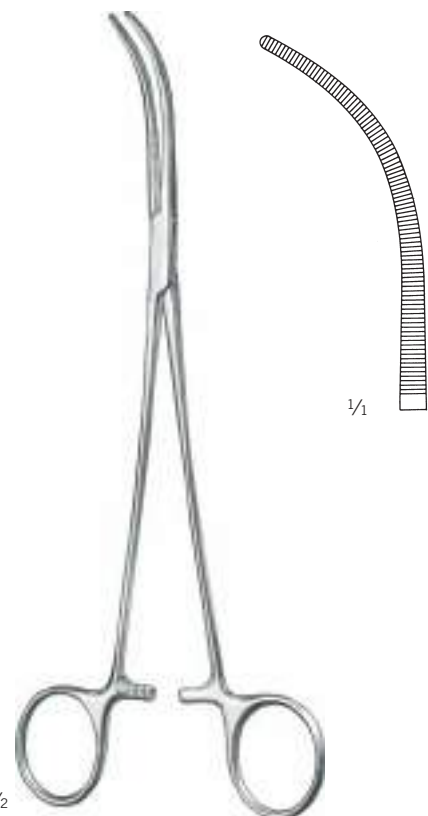

Overholt-Mixer
 13-427-21-07
 22 cm / 8 5/8"

Präparierklemmen
 Dissecting and Ligature Forceps
 Pinzas para preparación y ligadura
 Pinces à disséquer et à ligatures
 Pinze per preparazioni e legature



1/2

Roberts
 13-428-22-07 -
 13-429-22-07

1/1



13-428-22-07
 22,5 cm / 8 7/8"

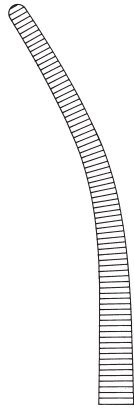

13-429-22-07
 22 cm / 8 5/8"



1/2

Sarot
 13-432-24-07 -
 13-433-24-07

1/1



13-432-24-07
 25 cm / 9 7/8"

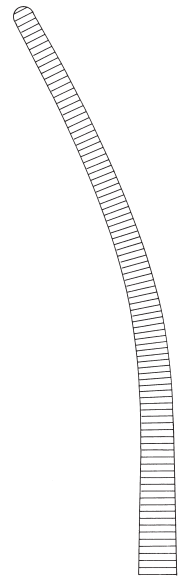

13-433-24-07
 24,5 cm / 9 5/8"

Präparierklemmen

Dissecting and Ligature Forceps
 Pinzas para preparación y ligadura
 Pincas à disséquer et à ligatures
 Pinze per preparazioni e legature

Arterienklemmen

Haemostatic Forceps
 Pinzas hemostáticas
 Pincas hémostatiques
 Pinze emostatiche



13



1/2

Craford
 13-439-18-07 -
 13-439-24-07

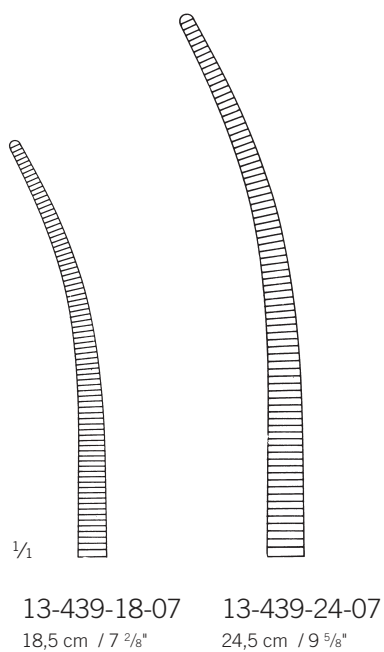

1/1

13-439-18-07
 18,5 cm / 7 2/8"

13-439-24-07
 24,5 cm / 9 5/8"



1/2

Craford-Sellors
 13-440-01-07 -
 13-440-03-07

Gefäßklemme
 Vascular clamp
 Pinza para vasos
 Pince vasculaires
 Pinza vascolari

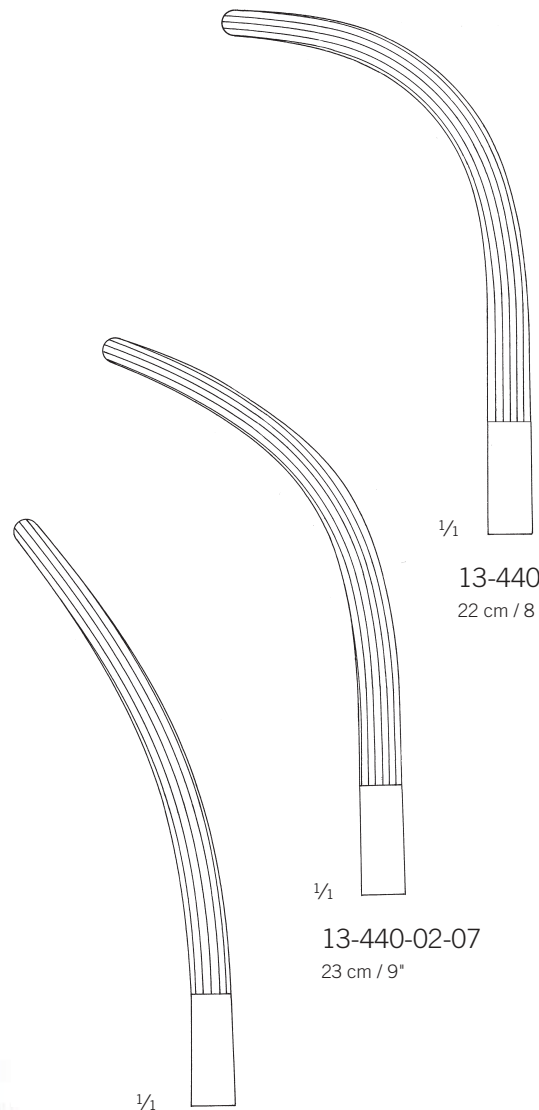

1/1

13-440-02-07
 23 cm / 9"

1/1

13-440-03-07
 22 cm / 8 5/8"

1/1

13-440-01-07
 24,5 cm / 9 5/8"

Präparierklemmen

Dissecting and Ligature Forceps

Pinzas para preparación y ligadura

Pinces à disséquer et à ligatures

Pinze per preparazioni e legature

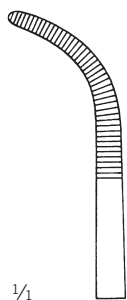

1/1

Fig. 1
13-443-01-07
20,5 cm / 8 1/8"

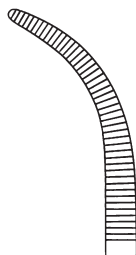

Fig. 2
13-443-02-07
20 cm / 7 7/8"

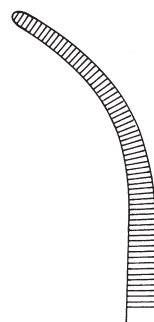

Fig. 3
13-443-03-07
21,5 cm / 8 4/8"

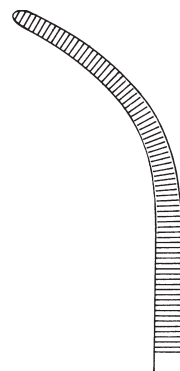

Fig. 4
13-443-04-07
22 cm / 8 5/8"

13-447-01-07
27 cm / 10 5/8"

13-447-02-07
26,5 cm / 10 3/8"

13-447-03-07
27,5 cm / 10 7/8"

13-447-04-07
28 cm / 11"

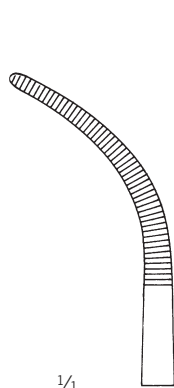

1/1

Fig. 5
13-443-05-07
21,5 cm / 8 4/8"

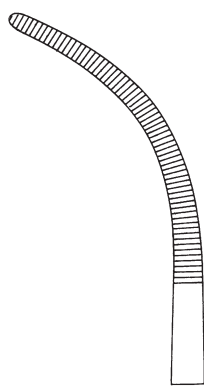

Fig. 6
13-443-06-07
21,5 cm / 8 2/8"

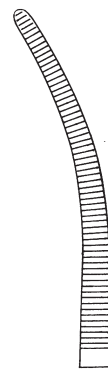

Fig. 7
13-443-07-07
22 cm / 8 5/8"

13-447-05-07
27,5 cm / 10 7/8"

13-447-06-07
28 cm / 11"

13-447-07-07
27,5 cm / 10 7/8"



1/2

Overholt-Geissendörfer
13-443-01-07 -
13-447-07-07

Arterienklemmen

Haemostatic Forceps

Pinzas hemostáticas

Pinces hémostatiques

Pinze emostatiche



finoLine

13



1/2

Overholt-Fino
13-448-00-07 -
13-448-06-07



1/1

13-448-00-07
21,5 cm / 8 4/8"

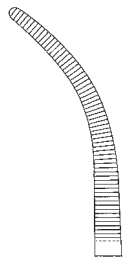

13-448-01-07
22 cm / 8 5/8"

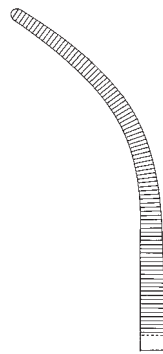

13-448-02-07
22,5 cm / 8 7/8"

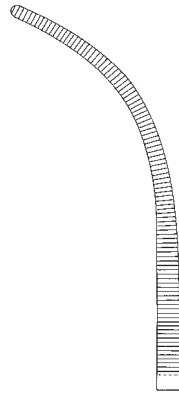

13-448-03-07
23 cm / 9"

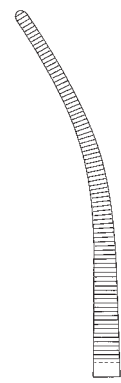

13-448-06-07
22,5 cm / 8 7/8"

Präparierklemmen
 Dissecting and Ligature Forceps
 Pinzas para preparación y ligadura
 Pinces à disséquer et à ligatures
 Pinze per preparazioni e legature

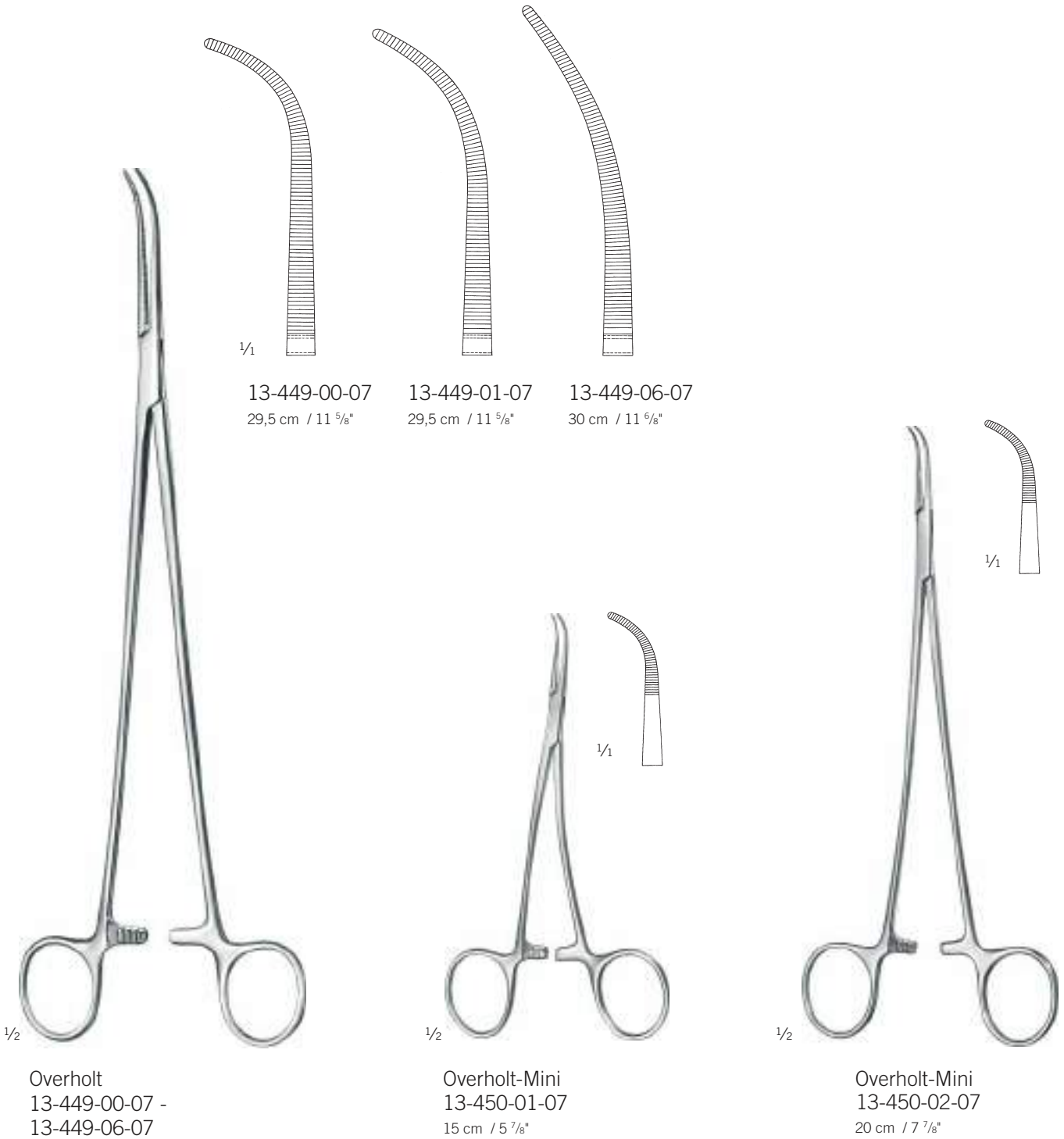

Präparierklemmen

Dissecting and Ligature Forceps
 Pinzas para preparación y ligadura
 Pincas à disséquer et à ligatures
 Pinze per preparazioni e legature

Arterienklemmen

Haemostatic Forceps
 Pinzas hemostáticas
 Pincas hémostatiques
 Pinze emostatiche



1/2

Gemini
 13-451-13-07 -
 13-451-28-07

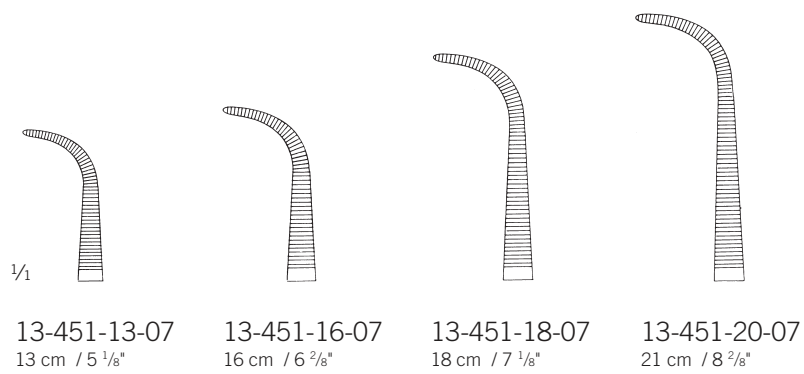

1/1

13-451-13-07
 13 cm / 5 1/8"

13-451-16-07
 16 cm / 6 2/8"

13-451-18-07
 18 cm / 7 1/8"

13-451-20-07
 21 cm / 8 2/8"

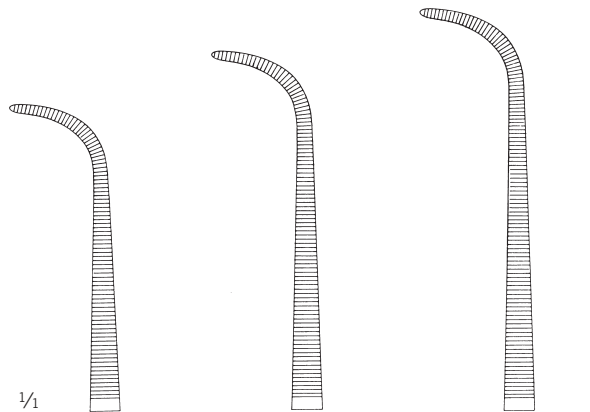

1/1

13-451-23-07
 23 cm / 9"

13-451-25-07
 25 cm / 9 7/8"

13-451-28-07
 28 cm / 11"



1/2

Mini-Gemini
 13-453-18-07 -
 13-453-28-07

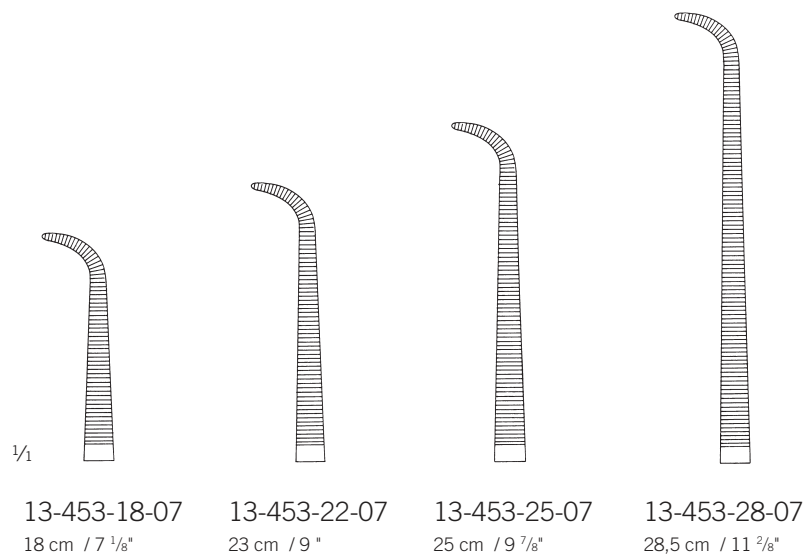

1/1

13-453-18-07
 18 cm / 7 1/8"

13-453-22-07
 23 cm / 9"

13-453-25-07
 25 cm / 9 7/8"

13-453-28-07
 28,5 cm / 11 2/8"

13

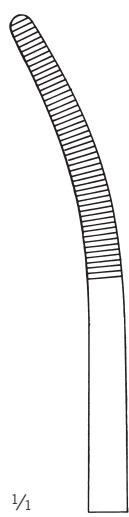

Fig. 1
 13-461-01-07
 24 cm / 9 4/8"

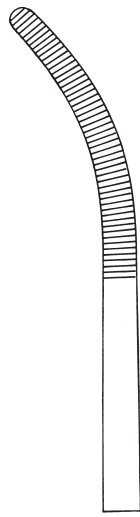

Fig. 2
 13-461-02-07
 24 cm / 9 4/8"

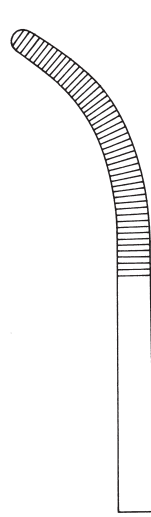

Fig. 3
 13-461-03-07
 23,5 cm / 9 2/8"



Fig. 4
 13-461-04-07
 24 cm / 9 4/8"

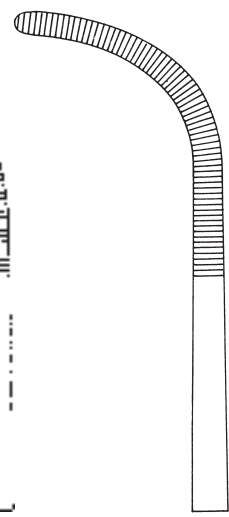

Fig. 5
 13-461-05-07
 24 cm / 9 4/8"

Rumel
 13-461-01-07 -
 13-461-05-07

Präparierklemmen

Dissecting and Ligature Forceps
Pinzas para preparación y ligadura
Pincas à disséquer et à ligatures
Pinze per preparazioni e legature

Arterienklemmen

Haemostatic Forceps
Pinzas hemostáticas
Pincas hémostatiques
Pinze emostatiche



13

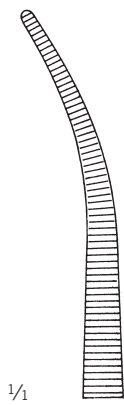

13-469-01-07
29,5 cm / 11 5/8"

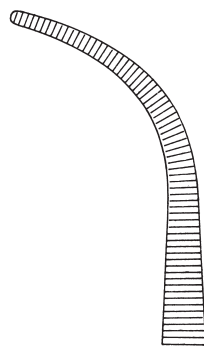

13-469-02-07
28,5 cm / 11 2/8"



13-471-14-07
13 cm / 5 1/8"

Zenker
13-469-01-07 -
13-469-02-07

Mixer-Baby
13-471-14-07
13 cm / 5 1/8"

Präparierklemmen

Dissecting and Ligature Forceps
 Pinzas para preparación y ligadura
 Pinces à disséquer et à ligatures
 Pinze per preparazioni e legature

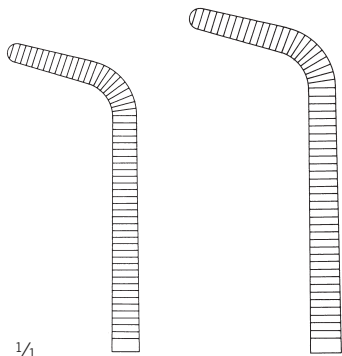

1/1

13-473-15-07
 16 cm / 6 2/8"

13-473-19-07
 17,5 cm / 6 7/8"

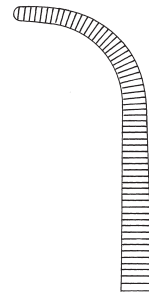

13-479-14-07
 15 cm / 5 7/8"

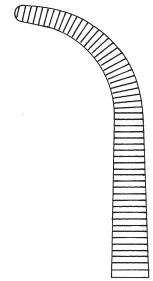

13-479-17-07
 18 cm / 7 1/8"

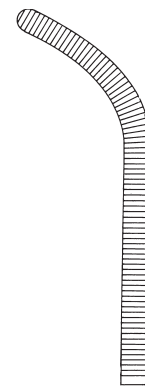

13-479-19-07
 18,5 cm / 7 2/8"



13-479-20-07
 20 cm / 7 7/8"



1/1
 13-479-23-07
 23 cm / 9"

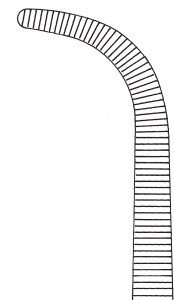

13-479-26-07
 26 cm / 10 2/8"



1/2

Mixer
 13-473-15-07 -
 13-473-19-07



1/2

O'Shaughnessy
 13-479-14-07 -
 13-479-26-07

Präparierklemmen

Dissecting and Ligature Forceps
Pinzas para preparación y ligadura
Pincès à disséquer et à ligatures
Pinze per preparazioni e legature

Arterienklemmen

Haemostatic Forceps
Pinzas hemostáticas
Pincès hémostatiques
Pinze emostatiche



Mixer
13-483-22-07
22,5 cm / 8 7/8"



Mixer
13-485-23-07
23 cm / 9"

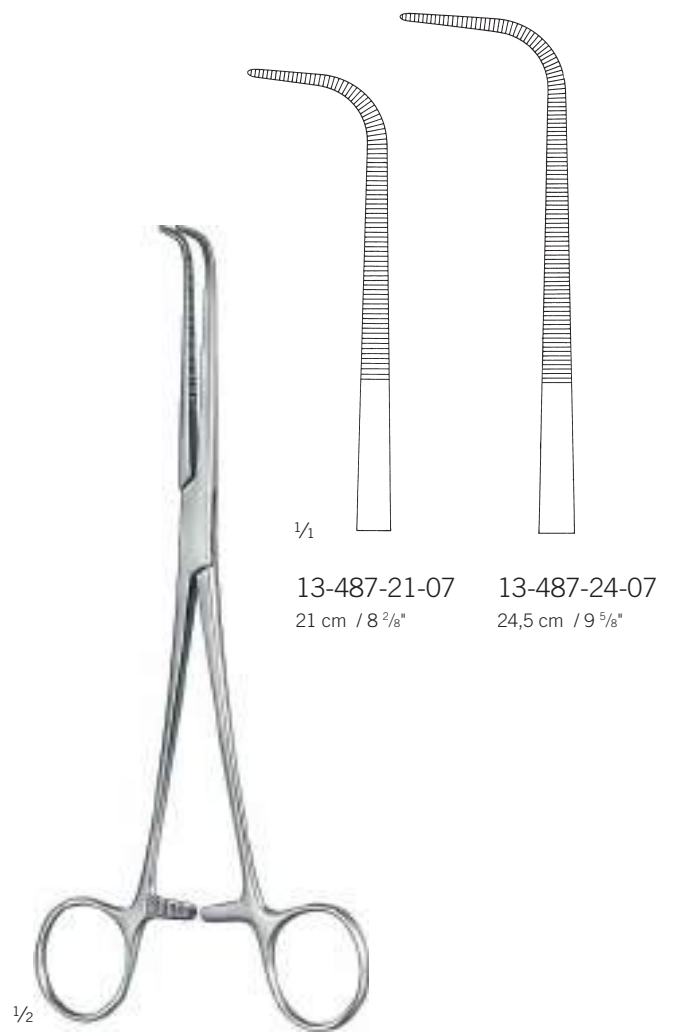

13-487-21-07
21 cm / 8 2/8"

13-487-24-07
24,5 cm / 9 5/8"

Präparierklemmen

Dissecting and Ligature Forceps
Pinzas para preparación y ligadura
Pincas à disséquer et à ligatures
Pinze per preparazioni e legature



1/2

13-491-22-07
22,5 cm / 8 7/8"

13-493-25-07
26 cm / 10 2/8"

13-495-28-07
28 cm / 11"

1/2

Mixer
13-491-22-07 -
13-495-28-07



1/2

1/2

McQuigg-Mixer
13-497-22-07
23,5 cm / 9 2/8"

Gallenkanalklemmen, Präparierklemmen

Bile Duct Clamps, Dissecting and Ligature Forceps

Pinzas para conducto biliar, Pinzas para preparación y ligadura

Pinces pour les voies biliaires, Pinces à disséquer et à ligatures

Pinze per vie biliari, Pinze per preparazioni e legature

Arterienklemmen

Haemostatic Forceps

Pinzas hemostáticas

Pinces hémostatiques

Pinze emostatiche

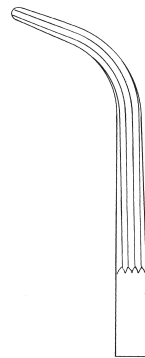

13-511-19-07
19,5 cm / 7 5/8"

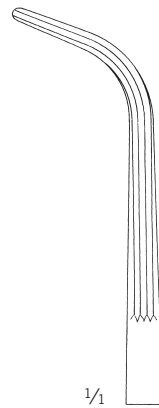

13-513-23-07
22,5 cm / 8 7/8"



1/1



1/2

Lower
13-501-18-07
18,5 cm / 7 1/4"



1/2

Lahey
13-511-19-07 -
13-513-23-07



1/2

Finochietto
13-521-24-07
24,5 cm / 9 5/8"

Tangentialklemmen, Nierenstiellklemmen

Tangential Forceps, Kidney Pedicle Clamps

Pinzas tangenciales, Pinzas para pedículo renal

Pinces tangentielles, Pince-clamps pour pédicules rénaux

Pinze tangenziali, Pinze per peduncoli renali

Atrauma

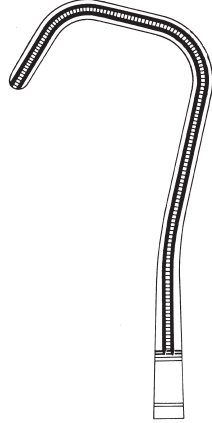
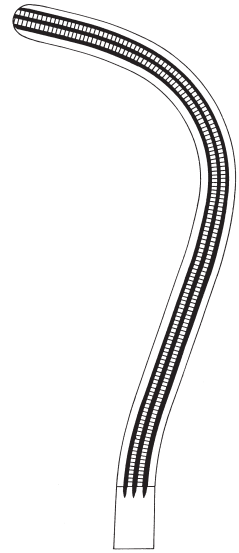

Fig. 1
13-527-01-07
25 cm / 9 ⁷/₈"



13-529-23-07
23 cm / 9"

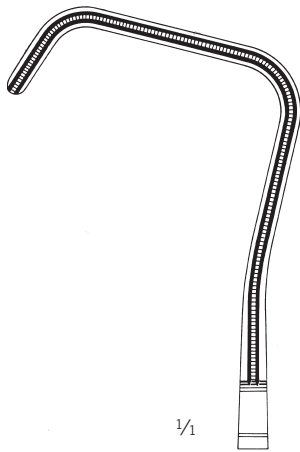
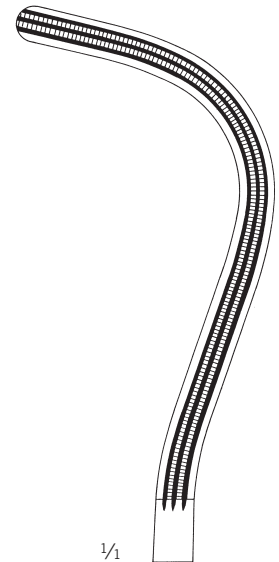

Fig. 2
13-527-02-07
26 cm / 10 ²/₈"



13-529-24-07
24 cm / 9 ⁴/₈"



1/2

Uro-Tangential
13-527-01-07 -
13-527-02-07



1/2

Guyon
13-529-23-07 -
13-529-24-07

Nierenstielklemmen

Kidney Pedicle Clamps
Pinzas para pedículo renal
Pince-clamps pour pédicules rénaux
Pinze per peduncoli renali

Arterienklemmen

Haemostatic Forceps
Pinzas hemostáticas
Pinces hémostatiques
Pinze emostatiche



1/1

13-531-20-07
19,5 cm / 7 5/8"

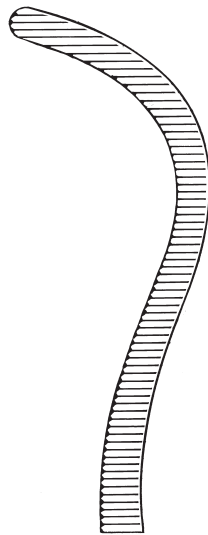

13-531-22-07
21,5 cm / 8 4/8"

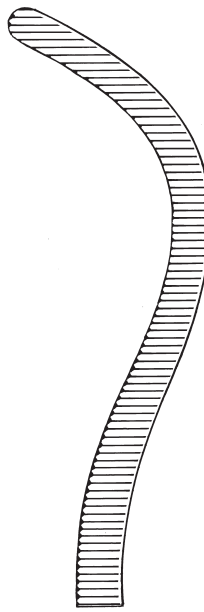

13-531-24-07
24,5 cm / 9 5/8"



1/1

Guyon
13-533-23-07
24 cm / 9 4/8"

1/2

1/2

Guyon
13-531-20-07 -
13-531-24-07

Gallenkanalklemmen

Bile Duct Clamps

Pinzas para conducto biliar

Pinces pour les voies biliaires

Pinze per vie biliari



Desjardins
13-571-21-07
21 cm / 8 $\frac{2}{8}$ "

Präparierklemmen

Dissecting and Ligature Forceps
 Pinzas para preparación y ligadura
 Pincès à disséquer et à ligatures
 Pinze per preparazioni e legature

Arterienklemmen

Haemostatic Forceps
 Pinzas hemostáticas
 Pincès hémostatiques
 Pinze emostatiche



13

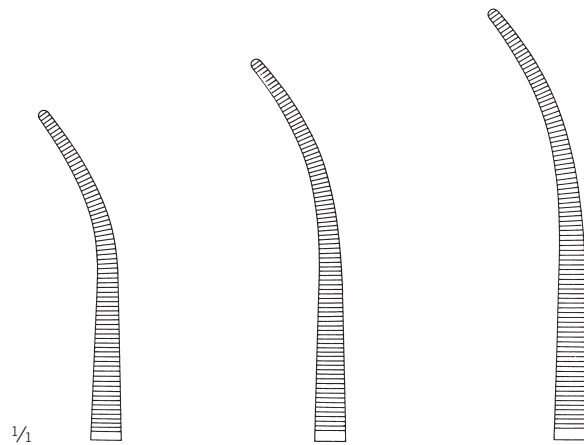

1/1
Fig. 1
 13-577-19-07
 19 cm / 7 4/8"

Fig. 1
 13-577-22-07
 22,5 cm / 8 7/8"

Fig. 1
 13-577-24-07
 23 cm / 9"

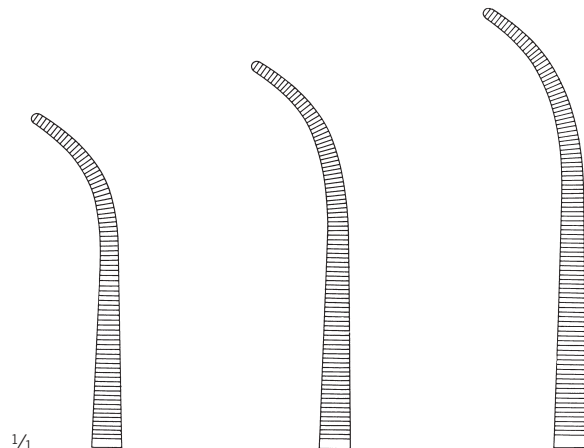

1/1
Fig. 2
 13-579-19-07
 19 cm / 7 4/8"

Fig. 2
 13-579-22-07
 22 cm / 8 5/8"

Fig. 2
 13-579-24-07
 23,5 cm / 9 2/8"

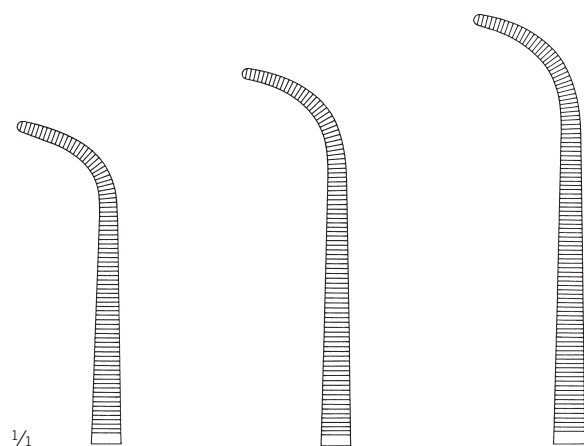

1/1
Fig. 3
 13-581-19-07
 18,5 cm / 7 2/8"

Fig. 3
 13-581-22-07
 21,5 cm / 8 4/8"

Fig. 3
 13-581-24-07
 23 cm / 9"



1/2
 Kelly
 13-577-19-07 -
 13-581-24-07

Präparierklemmen, Arterienklemmen

Dissecting and Ligature Forceps, Haemostatic Forceps

Pinzas para preparación y ligadura, Pinzas hemostáticas

Pinces à disséquer et à ligatures, Pinces hémostatiques

Pinze per preparazioni e legature, Pinze emostatiche



1/4

1/2

Lawrence
13-583-28-07
28 cm / 11"



1/4

1/2

Meeker
13-585-28-07
28 cm / 11"

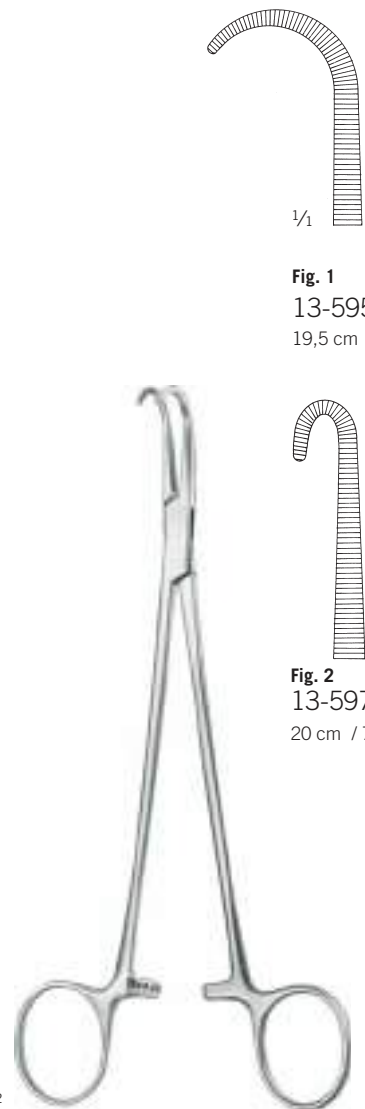

1/4

1/2

Negus
13-595-19-07 -
13-597-19-07

Fig. 1
13-595-19-07
19,5 cm / 7 5/8"

Fig. 2
13-597-19-07
20 cm / 7 7/8"

Hysterektomieklemmen

Hysterectomy Forceps
Pinzas para histerectomía
Pincas à hystérectomie
Pinze per isterectomia

Arterienklemmen

Haemostatic Forceps
Pinzas hemostáticas
Pincas hémostatiques
Pinze emostatiche



13



13-600-21-07
20,5 cm / 8 1/8"

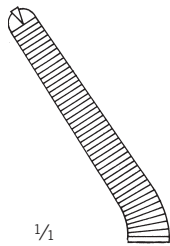

1/1

13-601-21-07
20 cm / 7 7/8"



1/2

Phaneuf
13-600-21-07 -
13-601-21-07



1/2

Heaney
13-613-19-07 -
13-615-23-07

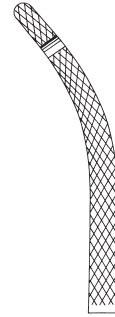

Fig. 1
13-613-19-07
19,5 cm / 7 5/8"

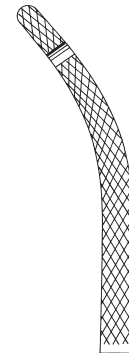

Fig. 1
13-613-21-07
21,5 cm / 8 4/8"

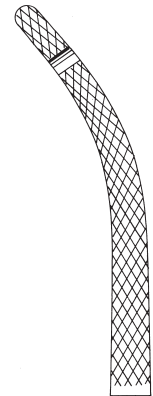

Fig. 1
13-613-23-07
24 cm / 9 4/8"



Fig. 2
13-615-19-07
19,5 cm / 7 5/8"

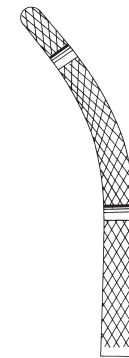

Fig. 2
13-615-21-07
21,5 cm / 8 4/8"

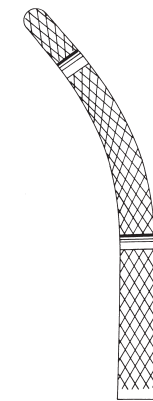
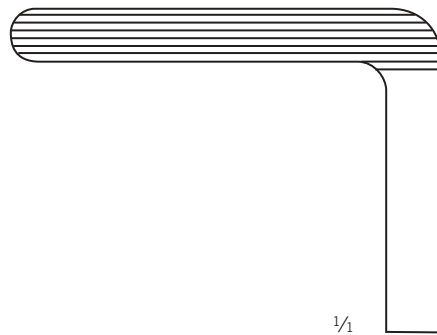

Fig. 2
13-615-23-07
24 cm / 9 4/8"

Vaginalklemmen

Vaginal Clamp
Pinzas vaginal
Pincas vaginales
Pinza vaginale



$\frac{1}{2}$
Wertheim-Cullen
13-625-21-07
21 cm / 8 $\frac{2}{8}$ "

Hysterektomieklemmen

Hysterectomy Forceps
Pinzas para histerectomía
Pincas à hystérectomie
Pinze per isterectomia

Arterienklemmen

Haemostatic Forceps
Pinzas hemostáticas
Pincas hémostatiques
Pinze emostatiche



Atrauma



13

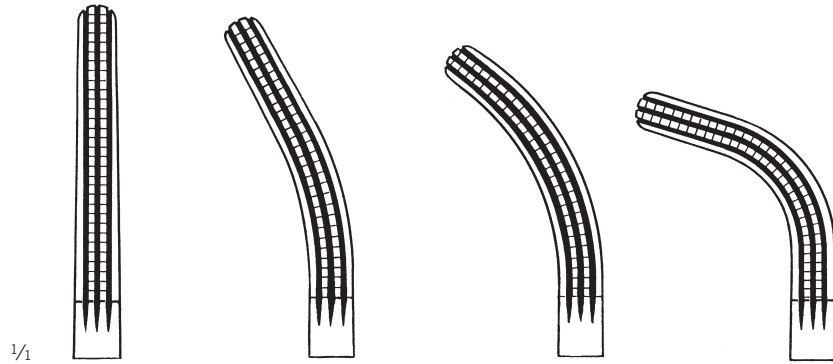

Fig. 1
13-635-10-07
21,5 cm / 8 4/8"

Fig. 2
13-635-20-07
21 cm / 8 2/8"

Fig. 3
13-635-30-07
21 cm / 8 2/8"

Fig. 4
13-635-40-07
20,5 cm / 8 1/8"

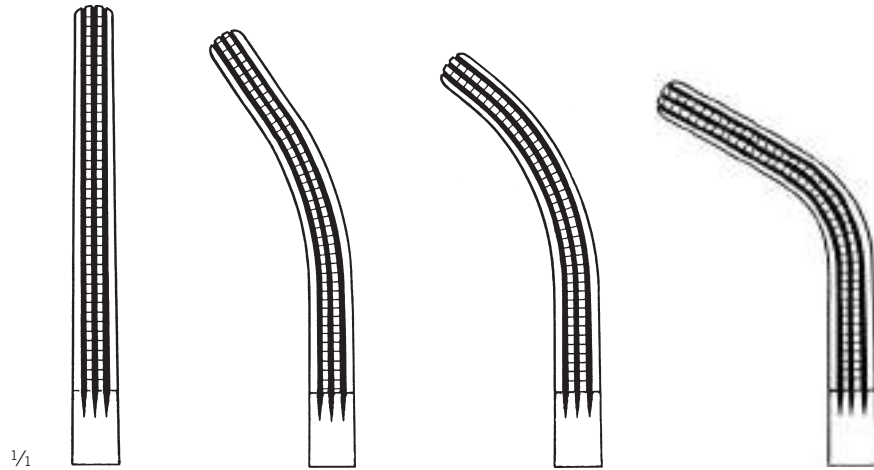

Fig. 1
13-637-10-07
25,5 cm / 10"

Fig. 2
13-637-20-07
25 cm / 9 7/8"

Fig. 3
13-637-30-07
24,5 cm / 9 4/8"

Fig. 4
13-637-35-07
24,5 cm / 9 4/8"



Rogers
13-635-10-07 -
13-637-35-07

Gallenkanalklemmen

Bile Duct Clamps

Pinzas para conducto biliar

Pinces pour les voies biliaires

Pinze per vie biliari



Moynihan
13-671-23-07
23 cm / 9"



Moynihan
13-673-24-07
23,5 cm / 9 2/8"

Hysterektomieklemmen

Hysterectomy Forceps
Pinzas para histerectomía
Pincas à hystérectomie
Pinze per isterectomia

Arterienklemmen

Haemostatic Forceps
Pinzas hemostáticas
Pincas hémostatiques
Pinze emostatiche



Wertheim
13-697-25-07
26 cm / 10 3/8"

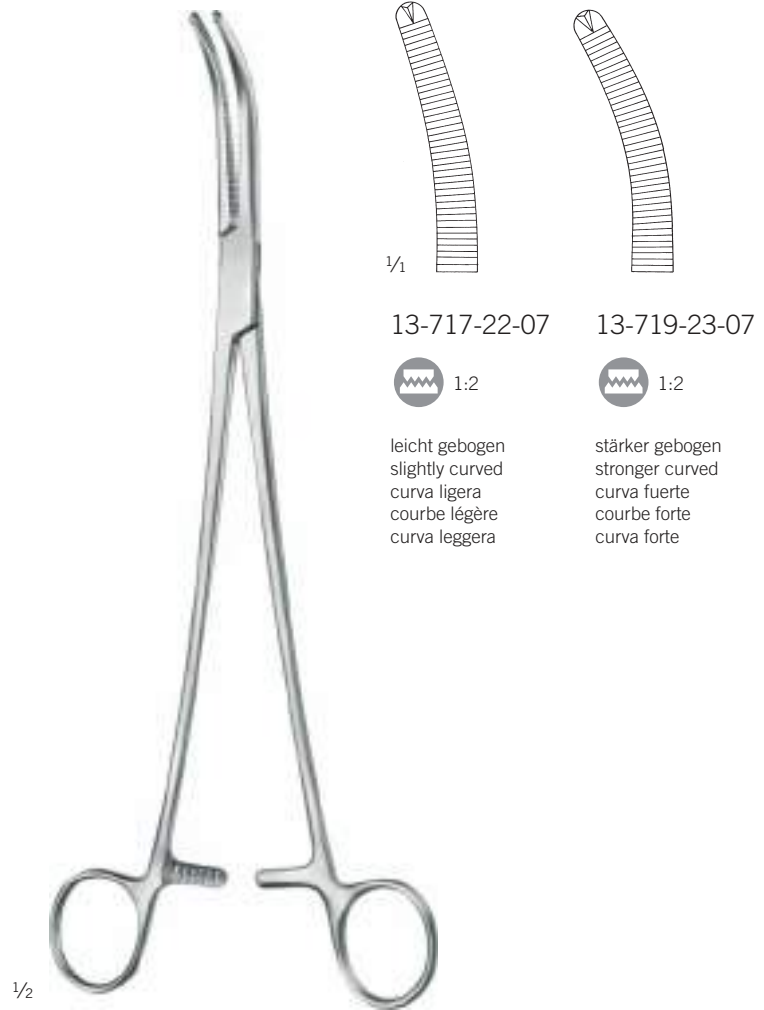

13-717-22-07

13-719-23-07



leicht gebogen
slightly curved
curva ligera
courbe légère
curva leggera



stärker gebogen
stronger curved
curva fuerte
courbe forte
curva forte

Peritoneumklemmen

Peritoneum Forceps
Pinzas para peritoneo
Pince pour le péritoine
Pinze per peritoneo



Mikulicz-Baby
13-721-14-07
14,5 cm / 5 7/8"



Mikulicz
13-725-18-07
18,5 cm / 7 3/8"

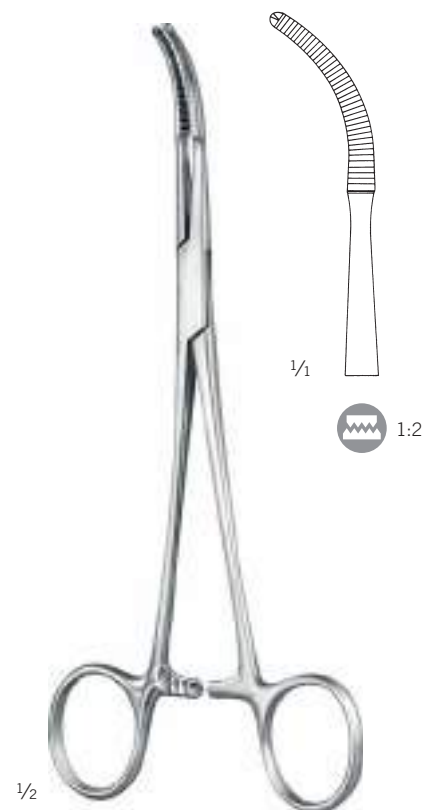

Mikulicz
13-727-20-07
20 cm / 7 7/8"

Peritoneumklemmen

Peritoneum Forceps
 Pinzas para peritoneo
 Pince pour le péritoine
 Pinze per peritoneo

Arterienklemmen

Haemostatic Forceps
 Pinzas hemostáticas
 Pincas hémostatiques
 Pinze emostatiche

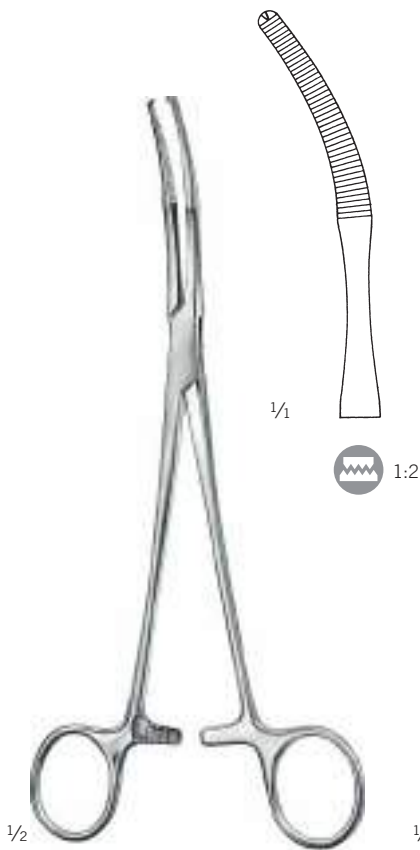

Mikulicz
 13-745-20-07
 20 cm / 7 7/8"



Mikulicz
 13-749-21-07
 20,5 cm / 8 1/8"

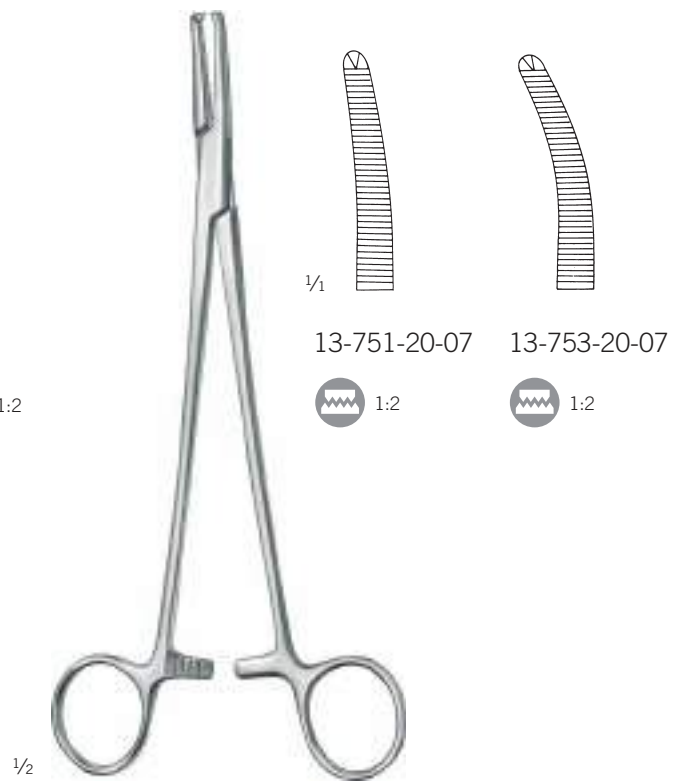

Faure
 13-751-20-07 -
 13-753-20-07
 21 cm / 8 3/8"

Tuchklemmen

Towel Clamps
Pinzas de campo
Pincas à champs
Pinze fissatele



1/2

Schädel
13-875-09-07

9 cm / 3 4/8"

scharf
sharp
agudo
pointu
acuto



1/2

Jones
13-881-05-07 -
13-881-09-07

scharf
sharp
agudo
pointu
acuto

13-881-05-07

5,5 cm / 2 1/8"

13-881-09-07

8,5 cm / 3 3/8"



1/2

Jones-Martin
13-883-09-07

8,5 cm / 3 3/8"

scharf, mit Schlauchhalter
sharp, with tube holder
agudo, con porta-tubo
pointu, avec clamp porte-tube
acuto, con porta-tubo



1/2

13-909-11-07

11 cm / 4 3/8"

13-909-13-07

13 cm / 5 1/8"

Backhaus
13-909-11-07 -
13-909-13-07

graziles Modell, scharf
delicate model, sharp
modelo delicado, aguda
modèle gracile, aiguë
modello delicato, acute



1/2

Backhaus
13-913-11-07

11 cm / 4 3/8"

scharf, mit Schlauchhalter
sharp, with tube holder
agudo, con porta-tubo
pointu, avec clamp porte-tube
acuto, con porta-tubo



1/2

Backhaus
13-915-08-07 -
13-915-15-07

scharf
sharp
agudo
pointu
acuto

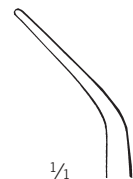

1/1

13-915-08-07

9 cm / 3 4/8"

13-915-11-07

11 cm / 4 3/8"

13-915-13-07

13 cm / 5 1/8"

13-915-15-07

16 cm / 6 2/8"

Tuchklemmen

Towel Clamps
Pinzas de campo
Pincas à champs
Pinze fissatele

Arterienklemmen

Haemostatic Forceps
Pinzas hemostáticas
Pincas hémostatiques
Pinze emostatiche

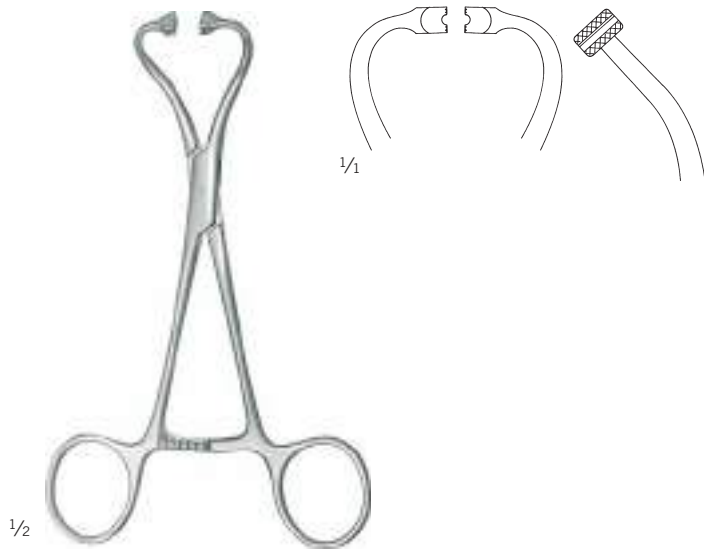

Peers-Bertram modif.
13-916-15-07

14,5 cm / 5 5/8"

weites Maul zur Schlauchfixierung
wide jaw for tube fixation
boca ancha para fijación de tubos
mors large pour fixation de tube
morso spalancato per fissare il tubo



Roeder
13-917-13-07

13,5 cm / 5 3/8"

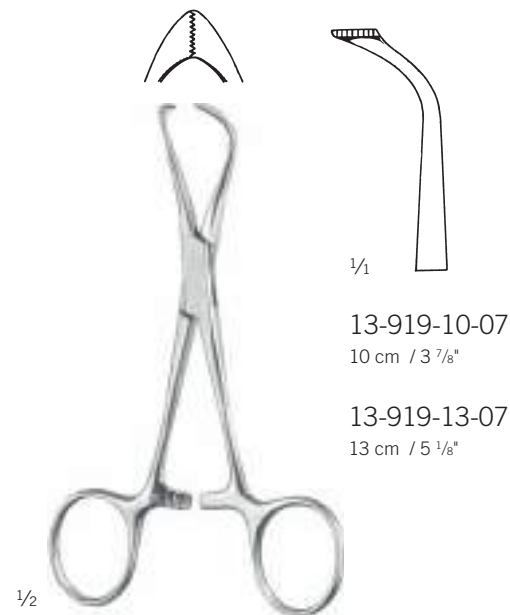

Lorna
13-919-10-07 -
13-919-13-07

fein gezahnt, breites Maul
fine serration, wide jaw
delicadamente dentada, boca ancha
avec dents fins, mors large
con denti fini, morso largo



Bernhard
13-921-16-07

16,5 cm / 6 4/8"

scharf
sharp
agudo
pointu
acuto

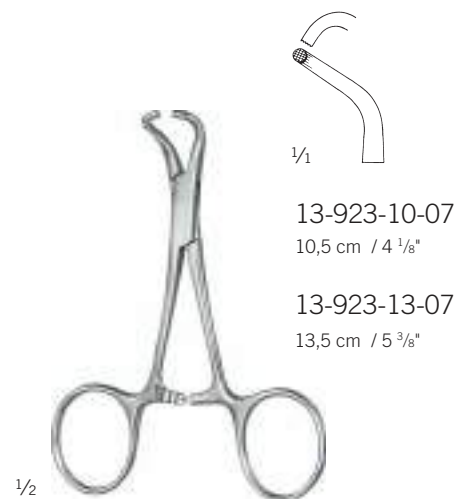

Tohoku
13-923-10-07 -
13-923-13-07

stumpf
blunt
romo
pointu
mousse

Tuchklemmen, Schlauchklemmen

Towel Clamps, Tubing Clamps

Pinzas de campo, Pinzas para tubos

Pinces à champs, Pinces presse-tubes

Pinze fissatele, Pinze serratubi

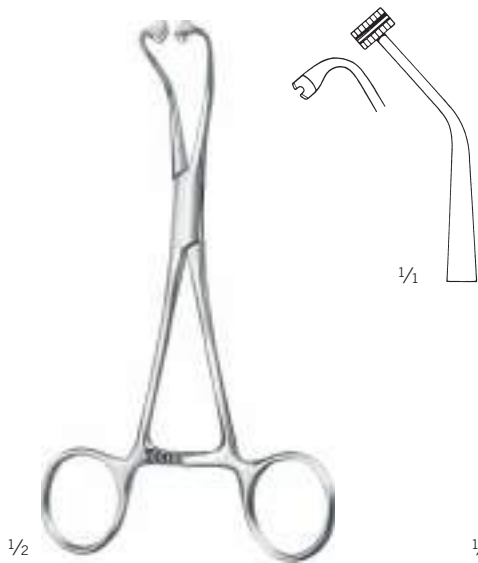

Peers-Bertram
13-923-14-07
14,5 cm / 5 5/8"



13-924-11-07
11,5 cm / 4 4/8"

13-924-14-07
14 cm / 5 4/8"

13-924-11-07 -
13-924-14-07

für Papierabdeckung
for paper drapes
para paños de papel
pour couverture en papier
per copertura di carta



Lane
13-935-20-07
19,5 cm / 7 5/8"

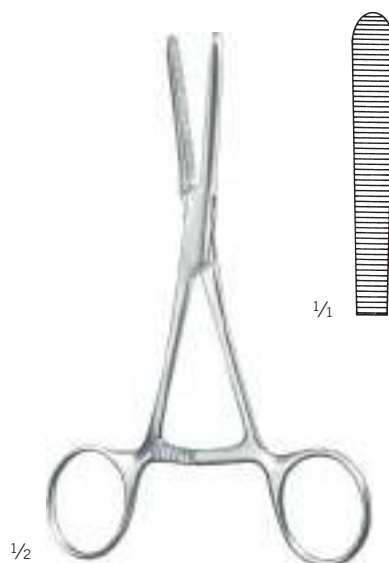

13-940-14-07
14 cm / 5 4/8"

extra lange Sperre
extra long ratchet
cremallera extra larga
cremaillère extrêmement longue
cremagliera stralunga

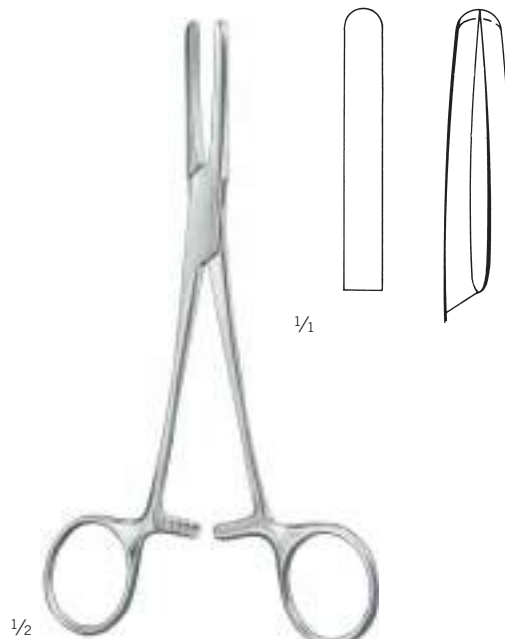

13-942-16-07
16,5 cm / 6 4/8"

glattes Maul
smooth jaw
boca lisa
mors lisse
morso liscio

Schlauchklemmen

Tubing Clamps
Pinzas para tubos
Pincas presse-tubes
Pinze serratubi

Arterienklemmen

Haemostatic Forceps
Pinzas hemostáticas
Pincas hémostatiques
Pinze emostatiche



13

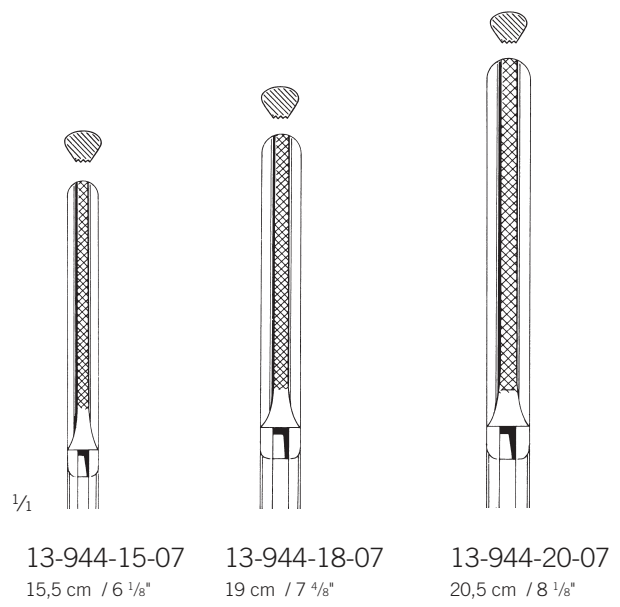

13-944-15-07 15,5 cm / 6 1/8"
13-944-18-07 19 cm / 7 4/8"
13-944-20-07 20,5 cm / 8 1/8"

13-944-15-07 -
13-944-20-07

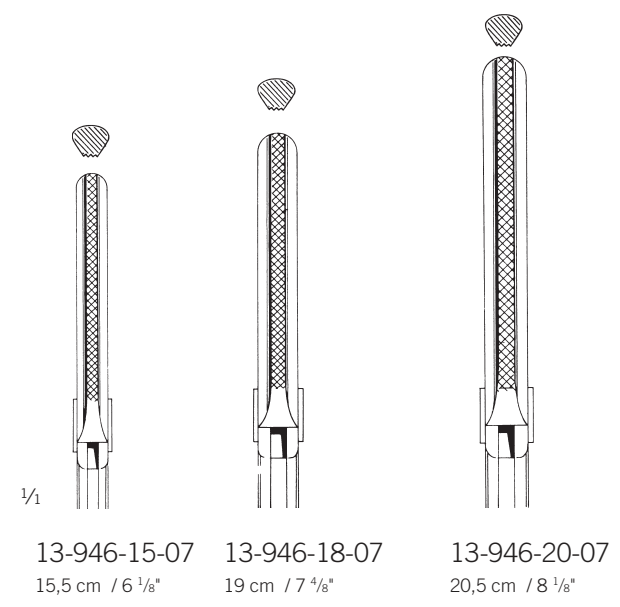

13-946-15-07 15,5 cm / 6 1/8"
13-946-18-07 19 cm / 7 4/8"
13-946-20-07 20,5 cm / 8 1/8"

13-946-15-07 -
13-946-20-07
mit Schutzbügel
with safety guard
con stribo de protección
avec protection
con protezione

Schlauchklemmen

Tubing Clamps

Pinzas para tubos

Pinces presse-tubes

Pinze serratubi



1/2

Brompton
13-948-01-04
16,5 cm / 6 1/8"

AI



1/2

Gunnar-Hey
13-948-02-07
18 cm / 7 1/8"

14

Tupfer- und Kornzangen
Cotton Swap Forceps
Pinzas para tampones y curaciones
Pinces à tampons et à pansements
Pinze per tamponi e per medicazione

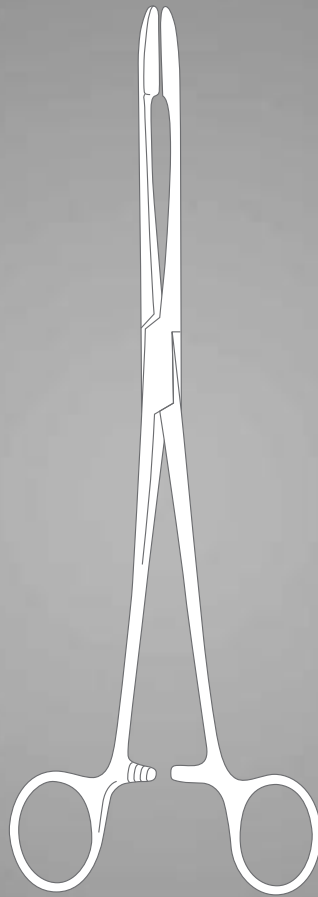

Tupferzangen

Dressing Forceps

Pinzas para tapones

Pinces à tampons

Pinze per tamponi

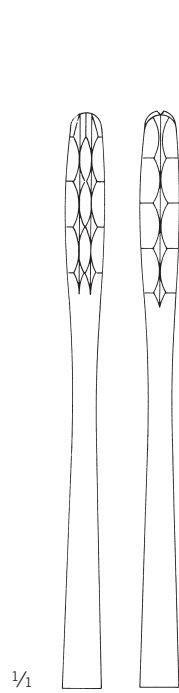

14-100-22-07
22,5 cm / 8 7/8"

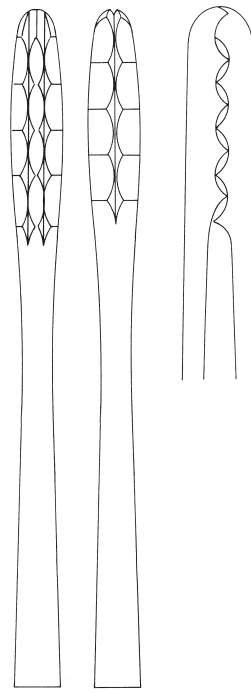

14-100-27-07
27 cm / 10 5/8"



Ulrich
14-100-22-07 -
14-101-27-07



14-101-22-07
22,5 cm / 8 7/8"

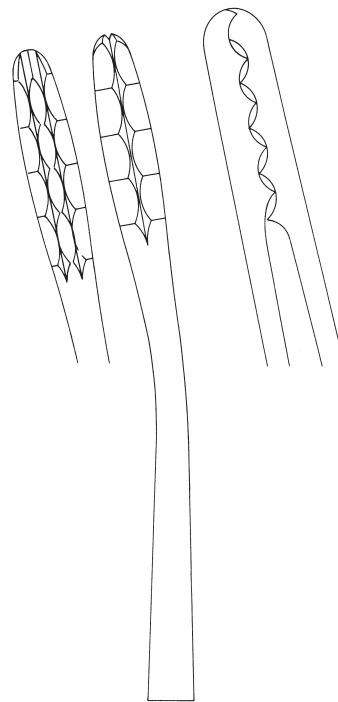

14-101-27-07
26,5 cm / 10 7/8"

Sinusklemmen, Kornzangen

Sinus Forceps, Dressing Forceps

Pinzas para vendajes, Pinzas para vendajes

Pinces Sinus, Pinces à pansements

Pinze per seni, Pinze per medicature

Tupfer- und Kornzangen

Cotton Swap Forceps

Pinzas para tampones y curaciones

Pinces à tampons et à pansements

Pinze per tamponi e per medicazione



1/2

Lister
14-110-13-07 -
14-110-18-07

1/4



14-110-13-07
13 cm / 5 1/8"



14-110-16-07
16 cm / 6 2/8"



14-110-18-07
18,5 cm / 7 2/8"



1/2

Martin
14-120-17-07
17,5 cm / 6 7/8"

1/4



Kornzangen

Dressing Forceps

Pinzas para vendajes

Pinces à pansements

Pinze per medicature



1/1

14-222-20-07

20,5 cm / 8 1/8"

14-222-22-07

22,5 cm / 8 7/8"

14-222-27-07

26,5 cm / 10 3/8"

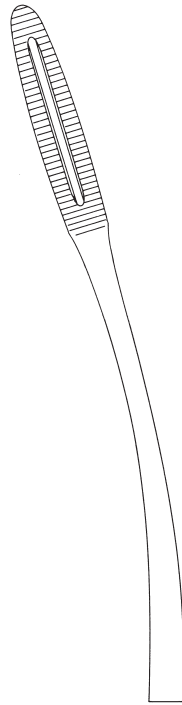

14-223-20-07

20,5 cm / 8 1/8"

14-223-22-07

22,5 cm / 8 7/8"

14-223-27-07

26,5 cm / 10 3/8"

1/1

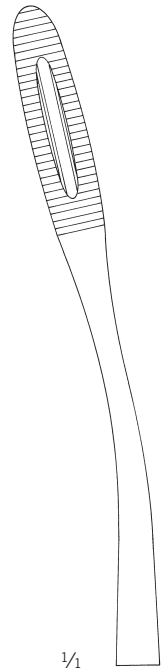

1/2



14-231-40-07

39,5 cm / 15 4/8"

Tunnelier-Kornzange

Tunneling Forceps

Pinza para tunelar

Pince pour tunnelisation

Pinza per tunnelare

Kornzangen

Dressing Forceps

Pinzas para vendajes

Pinces à pansements

Pinze per medicature

Tupfer- und Kornzangen

Cotton Swap Forceps

Pinzas para tampones y curaciones

Pinces à tampons et à pansements

Pinze per tamponi e per medicazione

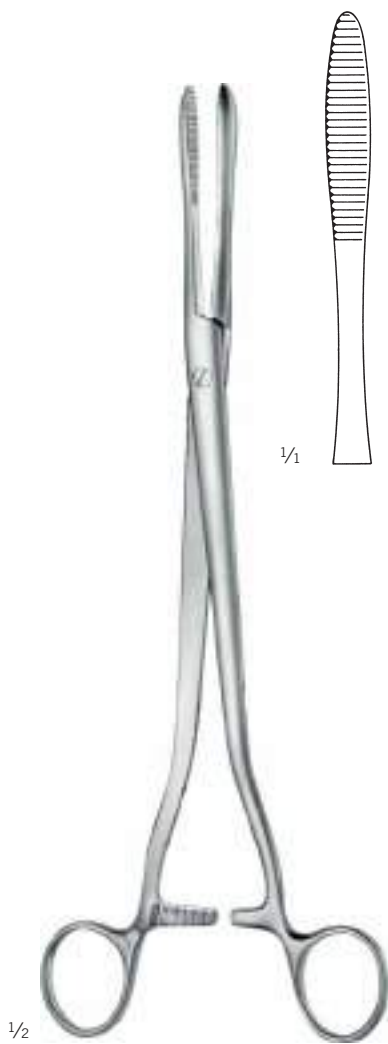

1/2

1/1

Collin
14-286-25-07
25 cm / 9 7/8"



1/2

1/1

Cheron
14-290-25-07
25 cm / 9 7/8"

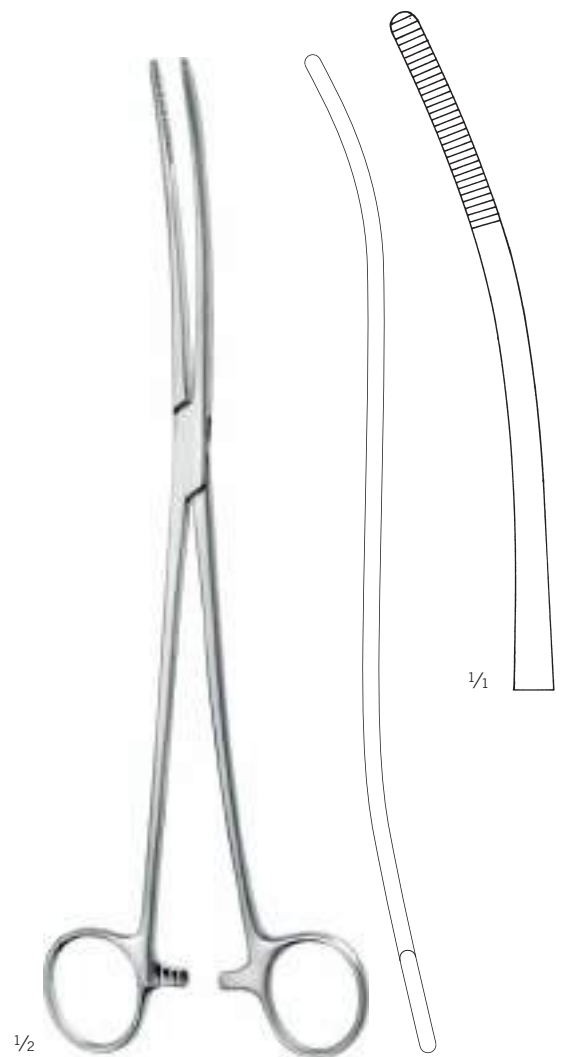

1/2

1/1

Bozemann
14-313-26-07
26 cm / 10 2/8"

S-Form
S-shape
forma S
courbés en S
curve in forma S

Schwammzangen

Sponge Forceps

Pinzas para tapones

Pinces pour éponges

Pinze per tamponi e spunge



1/2

Bergmann
14-320-24-07
24 cm / 9 4/8"



1/2

Förster
14-350-25-07 -
14-355-25-07



1/1

14-350-25-07
25 cm / 9 7/8"
glattes Maul
smooth jaw
boca lisa
mors lisse
morso liscio

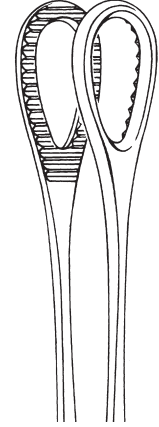

14-352-18-07
18 cm / 7 1/8"

14-352-20-07
20,5 cm / 8 1/8"

14-352-25-07
25 cm / 9 7/8"

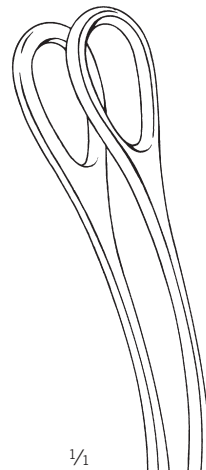

1/1

14-353-25-07
24,5 cm / 9 5/8"
glattes Maul
smooth jaw
boca lisa
mors lisse
morso liscio

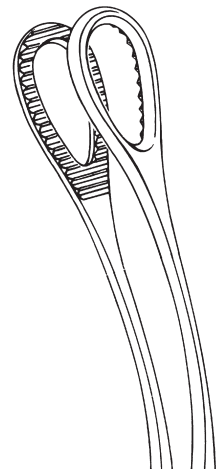

14-355-18-07
18 cm / 7 1/8"

14-355-20-07
20,5 cm / 8 1/8"

14-355-25-07
24,5 cm / 9 5/8"

Schwammzangen

Sponge Forceps

Pinzas para tapones

Pinces pour éponges

Pinze per tamponi e spunge

Tupfer- und Kornzangen

Cotton Swap Forceps

Pinzas para tampones y curaciones

Pinces à tampons et à pansements

Pinze per tamponi e per medicazione



14



1/2

Förster
14-360-25-07 -
14-361-25-07

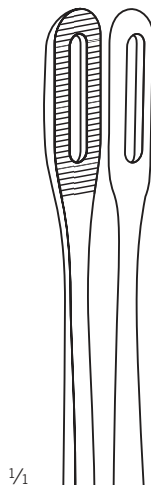

1/1

14-360-25-07
25 cm / 9 7/8"

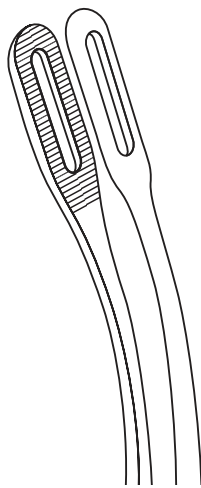

14-361-25-07
25 cm / 9 7/8"



1/2

Rampley
14-370-18-07 -
14-370-25-07

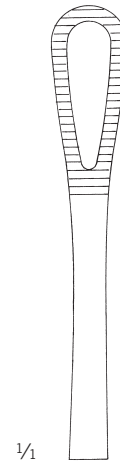

1/1

14-370-18-07
18 cm / 7 1/8"



14-370-25-07
24,5 cm / 9 5/8"

15

Wundhaken
Retractors
Separadores
Ecarteurs
Divaricatori

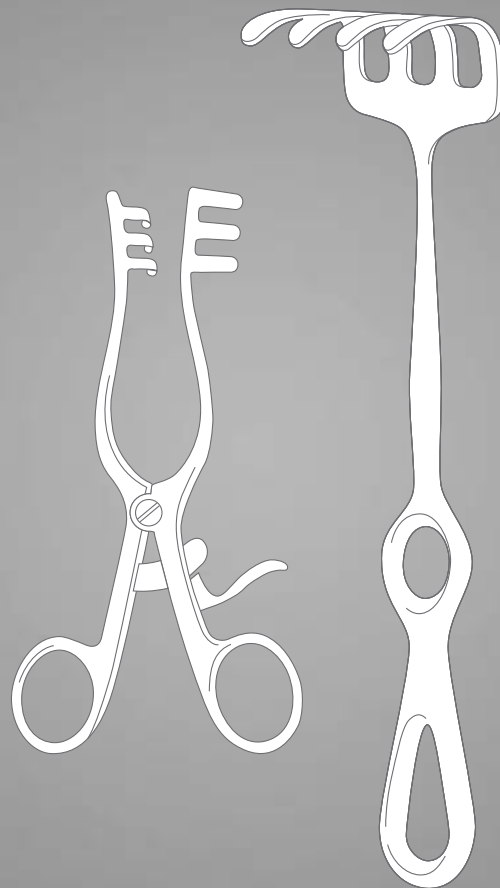

Mikrohäkchen, Hauthäkchen

Micro Hooklets, Skin Hooks

Micro Ganchitos, Ganchitos de piel

Micro Crochetes, Crochetes pour le peau

Micro Divaricatori, Divaricatori per pelle



Rasse
15-006-10-07
16 cm / 6 2/8"



Graefe
15-066-01-07 -
15-066-02-07
15 cm / 5 7/8"



15-066-01-07
scharf
sharp
agudo
pointu
acuto



15-066-02-07
stumpf
blunt
romo
mousse
smusso



15-068-01-07 -
15-068-04-07
16 cm / 6 2/8"
scharf
sharp
agudo
pointu
acuto



Fig. 1
15-068-01-07

Fig. 2
15-068-02-07

Fig. 3
15-068-03-07

Fig. 4
15-068-04-07

Fig. 5

Rasse
15-068-05-07
16 cm / 6 2/8"

Hauthäkchen, Wundhäkchen

Skin Hooks, Hooklets
 Ganchitos de piel, Ganchitos
 Crochetes pour le peau, Crochetes
 Divaricatori per pelle, Divaricatori

Wundhaken

Retractors
 Separadores
 Ecarteurs
 Divaricatori

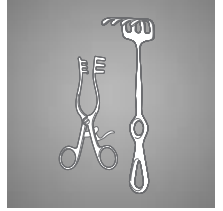

O'Connor
 15-070-16-07
 16 cm / 6 2/8"
 scharf
 sharp
 agudo
 pointu
 acuto

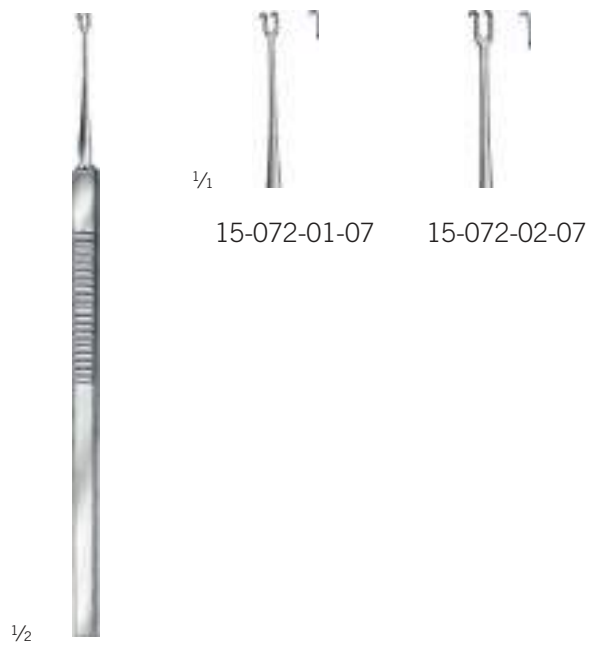

Guthrie
 15-072-01-07 -
 15-072-02-07
 16 cm / 6 2/8"
 scharf
 sharp
 agudo
 pointu
 acuto

 1/2	 1/4	 1/4	 1/4	 1/4	 1/4	scharf sharp agudo pointu acuto	15-074-01-07	15-074-02-07	15-074-03-07	15-074-04-07
						stumpf blunt romo mousse smusso	15-075-01-07	15-075-02-07	15-075-03-07	15-075-04-07

Wundhäkchen

Hooklets
Ganchitos
Crochetes
Divaricatori



15-078-02-07 -
15-079-04-07
15,5 cm / 6 1/8"



15-086-04-07 -
15-087-04-07
16,5 cm / 6 5/8"

15-088-12-07
12 cm / 4 6/8"
Gefäßhäkchen
Vessel Hook
Ganchito vascular
Micro-Ecarteurs pour vaisseaux
Divaricatore vascolare

Sattelhäkchen

Saddle Hooks

Ganchos en forma de silla

Ecarteurs sous forme de selle

Divaricatori a forma di sella

Wundhaken

Retractors

Separadores

Ecarteurs

Divaricatori

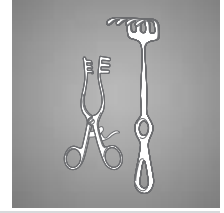

Desmarres

15-091-08-07 -

15-091-18-07

16 cm / 6 2/8"



15-093-12-07 -

15-093-18-07

16 cm / 6 2/8"

Langenbeck-Mini

15-095-10-07 -

15-095-22-07

16 cm / 6 2/8"

15

Wundhäkchen

Hooklets
Ganchitos
Crochetes
Divaricatori



15-099-16-07
14 x 8 mm

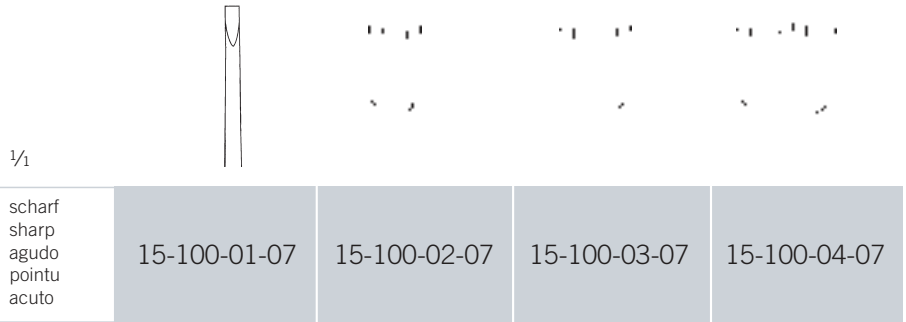

scharf sharp agudo pointu acuto	15-100-01-07	15-100-02-07	15-100-03-07	15-100-04-07
---	--------------	--------------	--------------	--------------

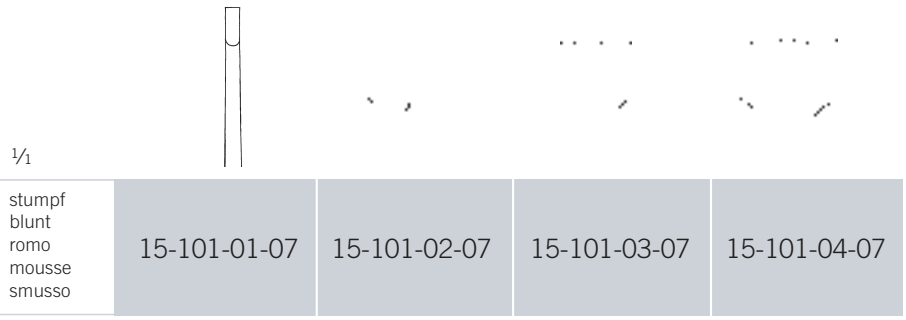

stumpf blunt romo mousse smusso	15-101-01-07	15-101-02-07	15-101-03-07	15-101-04-07
---	--------------	--------------	--------------	--------------

15-099-16-07
16 cm / 6 2/8"
stumpf
blunt
romo
mousse
smusso

15-101-01-07 -
15-101-04-07
16,5 cm / 6 4/8"



Meyerding
15-151-01-07 -
15-151-06-07
18 cm / 7 1/8"



Fig. 1
15-151-01-07
stumpf
blunt
romo
mousse
smusso
18 x 7 mm



Fig. 2
15-151-02-07
gezahnt
toothed
dentadas
dentelés
dentate
16 x 5 mm



Fig. 3
15-151-03-07
gezahnt
toothed
dentadas
dentelés
dentate
7 x 4 mm



Fig. 4
15-151-04-07
stumpf
blunt
romo
mousse
smusso
12 x 4 mm



Fig. 5
15-151-05-07
sattelförmig
saddle shaped
forma de silla
sous forme de selle
forma di sella
8 x 4 mm



Fig. 6
15-151-06-07
scharf
sharp
agudo
pointu
acuto
7 x 9 mm

Wundhäkchen

Hooklets
Ganchitos
Crochetes
Divaricatori

Wundhaken

Retractors
Separadores
Ecarteurs
Divaricatori

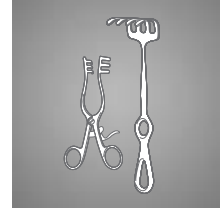

1/2



1/1

Fig. 1
15-161-01-07
20 x 6 mm



Fig. 2
15-161-02-07
10 x 6 mm

Senn-Green
15-161-01-07 -
15-161-02-07
16 cm / 6 2/8"



1/2



1/1

8 x 4,5 mm

15-164-14-07

15 x 5,5 mm



Ragnell-Davis
15-164-14-07
15 cm / 5 7/8"



1/2

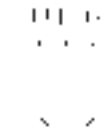

1/1

15-166-16-07
scharfe Zähne
sharp prongs
garfios agudos
dents pointus
denti acuti

Blätter
blades
hojas
lames
lame

20 x 7 mm



15-167-16-07
stumpfe Zähne
blunt prongs
garfios romos
dents mousses
denti smussi

Blätter
blades
hojas
lames
lame

20 x 7 mm

Senn-Miller
15-166-16-07 -
15-167-16-07
16 cm / 6 2/8"



1/2



1/1

Cushing
15-170-20-07
20,5 cm / 8 1/8"

15

Sattelhäkchen

Saddle Hooks

Ganchos en forma de silla

Ecarteurs sous forme de selle

Divaricatori a forma di sella

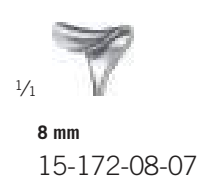

Cushing
15-171-08-07 -
15-171-18-07
20,5 cm / 8 1/8"

Cushing
15-172-08-07 -
15-172-18-07
24 cm / 9 4/8"

Sattelhäkchen

Saddle Hooks

Ganchos en forma de silla

Ecarteurs sous forme de selle

Divaricatori a forma di sella

Wundhaken

Retractors

Separadores

Ecarteurs

Divaricatori



1/1



4 mm

15-174-04-07



6 mm

15-174-06-07



8 mm

15-174-08-07



11 mm

15-174-11-07



15 mm

15-174-15-07



17 mm

15-174-17-07



20 mm

15-174-20-07



23 mm

15-174-23-07

1/2



Gil-Vernet

15-174-04-07 -

15-174-23-07

24 cm / 9 4/8"

biegsamer Schaft

malleable shaft

vástago maleable

tige malléable

asta malleabili

Venenhäkchen, Wundhäkchen

Vein Hooks

Ganchitos para venas

Ecarteurs pour veines

Divaricatori per veni



1/1

15-176-01-07

schmal
narrow
estrecho
étroit
stretto

15-176-02-07

breit
wide
ancho
large
largo

1/2

Brom
15-176-01-07 -
15-176-02-07
19 cm / 7 4/8"



1/1

Fig. 1

15-191-01-07

glattes Blattende
smooth blade end
valva lisa
extrémité de la lame lisse
valva liscia

Fig. 2

15-191-02-07

gezahntes Blattende
toothed blade end
valva dentada
extrémité de la lame dentelé
valva dentada

1/2

Strandell-Stille
15-191-01-07 -
15-191-02-07
19 cm / 7 4/8"



1/2

Kaye-Millard
15-192-02-07
8 cm / 3 1/8"
scharf
sharp
agudo
pointu
acuto

Wundhaken, Wundhäkchen

Retractors
Separadores
Ecarteurs
Divaricatori

Wundhaken

Retractors
Separadores
Ecarteurs
Divaricatori

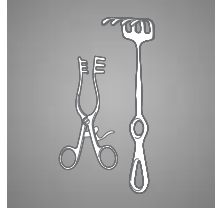

1/1

15-195-01-07
13 x 6 mm



15-195-02-07
12 x 11 mm



15-195-03-07
15 x 12 mm



1/2

Klapp
15-195-01-07 -
15-195-03-07
17,5 cm / 6 7/8"
stumpf
blunt
romo
mousse
smusso

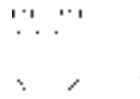

1/1

15-200-04-07
scharf
sharp
agudo
pointu
acuto



15-201-04-07
stumpf
blunt
romo
mousse
smusso



1/2

15-200-04-07 -
15-201-04-07
16,5 cm / 6 4/8"

15

Wundhaken

Retractors
Separadores
Ecarteurs
Divaricatori

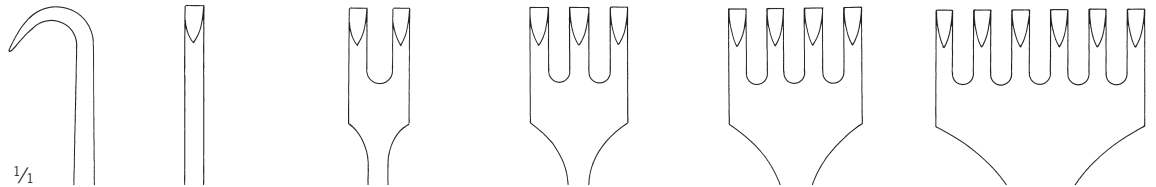

1/1

scharf sharp agudo pointu acuto	15-210-01-07	15-210-02-07	15-210-03-07	15-210-04-07	15-210-06-07
---	--------------	--------------	--------------	--------------	--------------

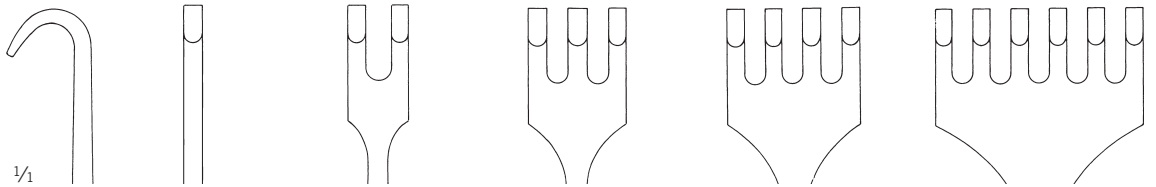

1/1

stumpf blunt romo mousse smusso	15-211-01-07	15-211-02-07	15-211-03-07	15-211-04-07	15-211-06-07
---	--------------	--------------	--------------	--------------	--------------



1/2

Volkman
15-210-01-07 -
15-211-06-07
21,5 cm / 8 1/8"

Wundhaken

Retractors
Separadores
Ecarteurs
Divaricatori

Wundhaken

Retractors
Separadores
Ecarteurs
Divaricatori

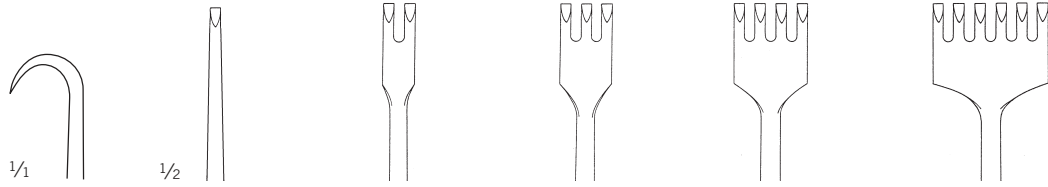
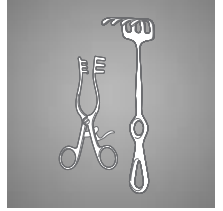

scharf sharp agudo pointu acuto	15-220-01-07	15-220-02-07	15-220-03-07	15-220-04-07	15-220-06-07
---	--------------	--------------	--------------	--------------	--------------

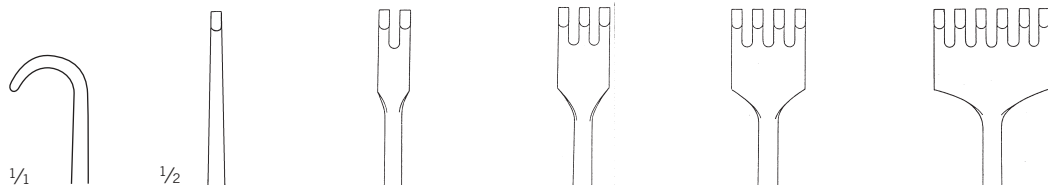

stumpf blunt romo mousse smusso	15-221-01-07	15-221-02-07	15-221-03-07	15-221-04-07	15-221-06-07
---	--------------	--------------	--------------	--------------	--------------

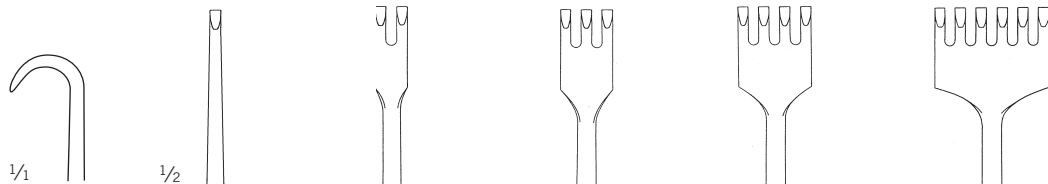

halbscharf semi-sharp semi-agudo semi-pointu semi-acuto	15-222-01-07	15-222-02-07	15-222-03-07	15-222-04-07	15-222-06-07
---	--------------	--------------	--------------	--------------	--------------



1/2

Volkman
15-220-01-07 -
15-222-06-07
22,5 cm / 8 7/8"

15

Wundhaken

Retractors
Separadores
Ecarteurs
Divaricatori



1/2

Volkman
15-230-01-07

21,5 cm / 8 4/8"

scharf
sharp
agudo
pointu
acuto



1/2

Volkman
15-231-01-07

21,5 cm / 8 4/8"

stumpf
blunt
romo
mousse
smusso



1/2

15-232-01-07

21,5 cm / 8 4/8"

scharf
sharp
agudo
pointu
acuto

Wundhaken

Retractors
Separadores
Ecarteurs
Divaricatori

Wundhaken

Retractors
Separadores
Ecarteurs
Divaricatori

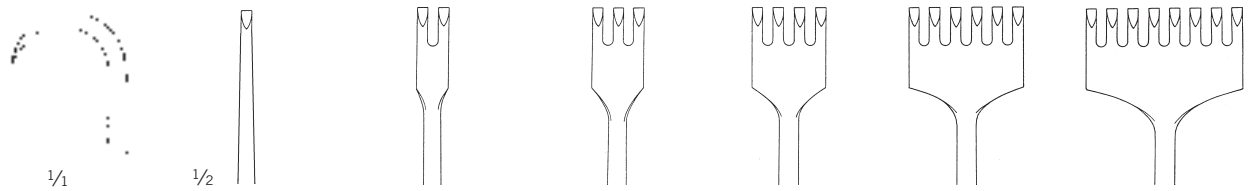
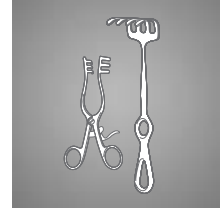

scharf sharp agudo pointu acuto	15-240-01-07	15-240-02-07	15-240-03-07	15-240-04-07	15-240-06-07	15-240-08-07
---	--------------	--------------	--------------	--------------	--------------	--------------

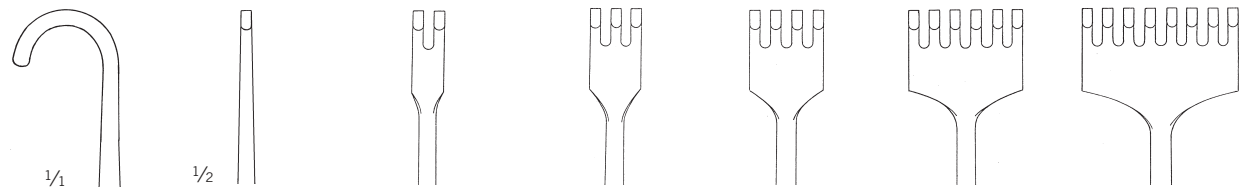

stumpf blunt romo mousse smusso	15-241-01-07	15-241-02-07	15-241-03-07	15-241-04-07	15-241-06-07	15-241-08-07
---	--------------	--------------	--------------	--------------	--------------	--------------

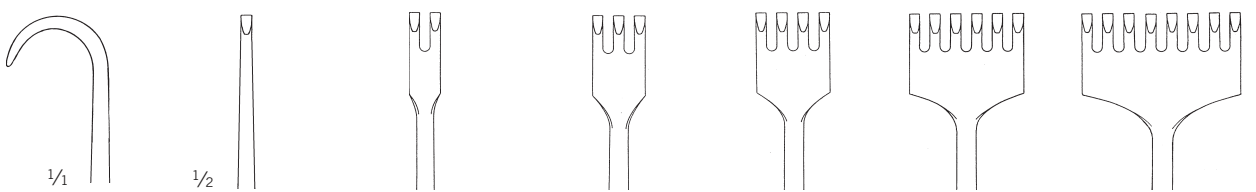

halbscharf semi-sharp semi-agudo semi-pointu semi acuto	15-242-01-07	15-242-02-07	15-242-03-07	15-242-04-07	15-242-06-07	15-242-08-07
---	--------------	--------------	--------------	--------------	--------------	--------------



1/2

Kocher
15-240-01-07 -
15-242-08-07
22,5 cm / 8 7/8"

15

Wundhaken

Retractors
Separadores
Ecarteurs
Divaricatori

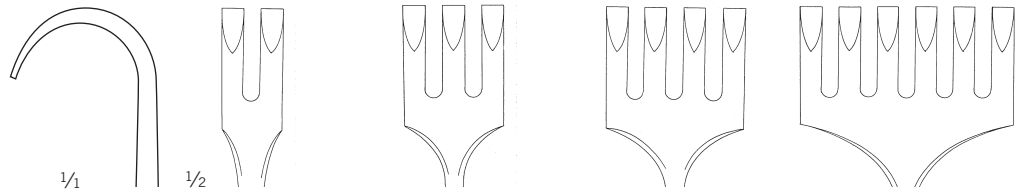

scharf sharp agudo pointu acuto	15-245-02-07	15-245-03-07	15-245-04-07	15-245-06-07
---	--------------	--------------	--------------	--------------

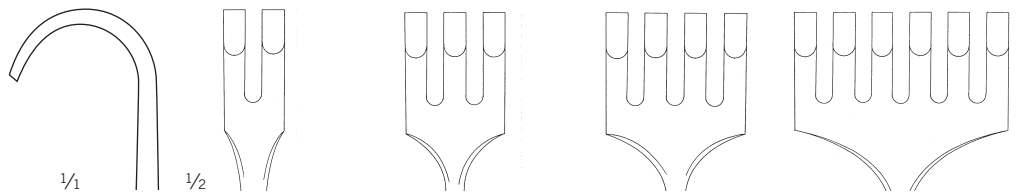

stumpf blunt romo mousse smusso	15-246-02-07	15-246-03-07	15-246-04-07	15-246-06-07
---	--------------	--------------	--------------	--------------



1/2

Martin
15-245-02-07 -
15-246-06-07
22,5 cm / 8 7/8"

Wundhaken

Retractors
Separadores
Ecarteurs
Divaricatori

Wundhaken

Retractors
Separadores
Ecarteurs
Divaricatori



15

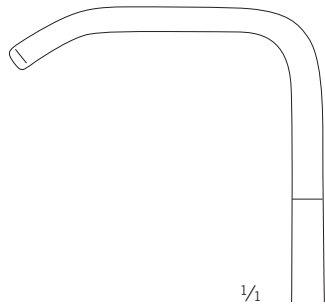

1/1

37 x 30 mm

1/2

Ollier
15-251-03-07

24,5 cm / 9 5/8"

stumpf
blunt
romo
mousse
smusso

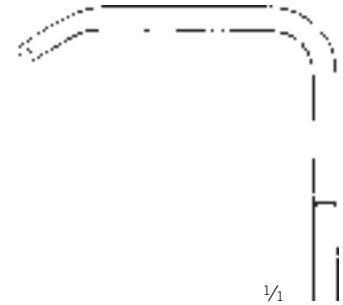

1/1

39 x 60 mm

1/2

Ollier
15-253-04-07

23 cm / 9"

stumpf
blunt
romo
mousse
smusso

Wundhaken

Retractors
Separadores
Ecarteurs
Divaricatori



1/2

Wassmund
15-261-02-07
20,5 cm / 8 1/8"

1/1

33 x 20 mm



1/2

Körte
15-266-08-07-
15-267-08-07
24,5 cm / 9 5/8"



1/1

25 x 40 mm
15-266-08-07
scharf
sharp
agudo
pointu
acuto



1/1 | :

25 x 40 mm
15-267-08-07
stumpf
blunt
romo
mousse
smusso

Wundhaken

Retractors
Separadores
Ecarteurs
Divaricatori

Wundhaken

Retractors
Separadores
Ecarteurs
Divaricatori

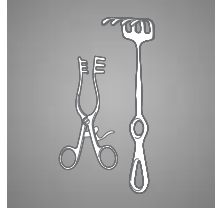

1/1

40 x 40 mm
15-281-04-07



45 x 50 mm
15-283-05-07



50 x 60 mm
15-287-06-07



70 x 70 mm
15-289-07-07



1/2

Israel
15-281-04-07 -
15-289-07-07

24,5 cm / 9 5/8"

stumpf
blunt
romo
mousse
smusso

15

Wundhaken

Retractors
Separadores
Ecarteurs
Divaricatori

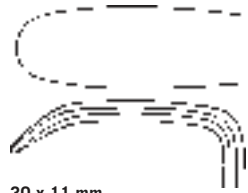

30 x 11 mm
15-291-01-07

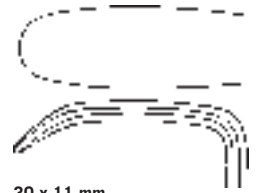

30 x 11 mm
15-293-01-07



30 x 14 mm
15-291-02-07



30 x 14 mm
15-293-02-07

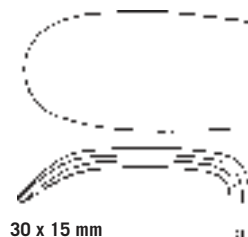

30 x 15 mm
15-291-03-07

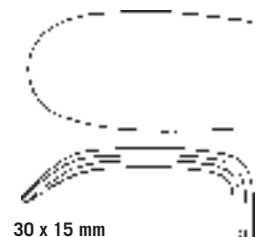

30 x 15 mm
15-293-03-07

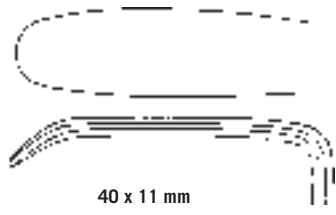

40 x 11 mm
15-291-04-07

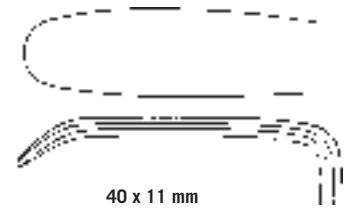

40 x 11 mm
15-293-04-07

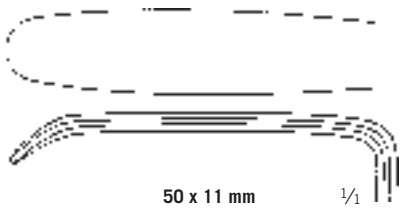

50 x 11 mm $\frac{1}{1}$
15-291-05-07

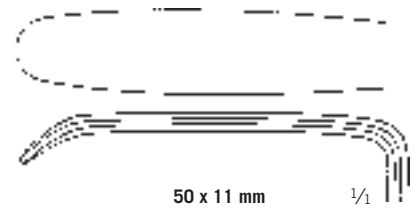

50 x 11 mm $\frac{1}{1}$
15-293-05-07



$\frac{1}{2}$

Langenbeck
15-291-01-07 -
15-291-05-07
22 cm / 8 $\frac{5}{8}$ "



$\frac{1}{2}$

Langenbeck
15-293-01-07 -
15-293-05-07
22 cm / 8 $\frac{5}{8}$ "

Wundhaken

Retractors
Separadores
Ecarteurs
Divaricatori

Wundhaken

Retractors
Separadores
Ecarteurs
Divaricatori

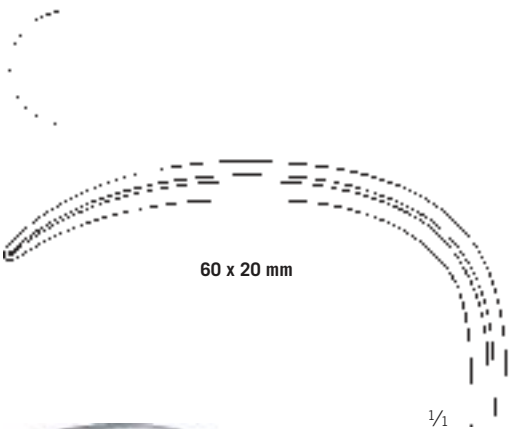
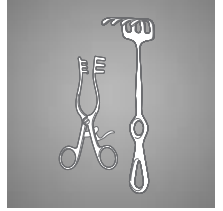

60 x 20 mm

1/2



1/2

Langenbeck
15-295-21-07
21 cm / 8 3/8"

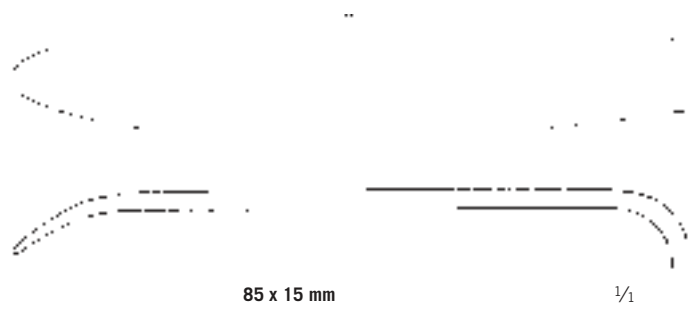

85 x 15 mm

1/2



1/2

Langenbeck
15-297-21-07
22,5 cm / 8 7/8"

15

Wundhaken

Retractors
Separadores
Ecarteurs
Divaricatori



1/2

Langenbeck
15-299-01-07
21 cm / 8 2/8"

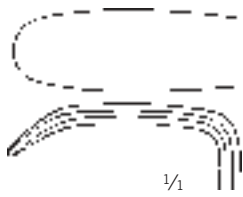

43 x 13 mm
15-299-01-07



1/2

Langenbeck-Green
15-301-16-07 -
15-301-25-07
16 cm / 6 2/8"

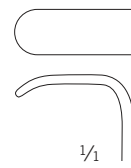

6 x 16 mm
15-301-16-07

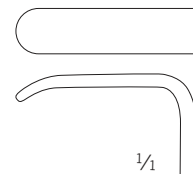

6 x 25 mm
15-301-25-07

Wundhaken

Retractors
Separadores
Ecarteurs
Divaricatori

Wundhaken

Retractors
Separadores
Ecarteurs
Divaricatori

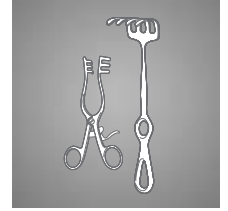

1/2

Lahey
15-307-19-07
19,5 cm / 7 5/8"

1/2

1/1

29 x 6 mm



1/2

Little
15-313-20-07
20,5 cm / 8 1/8"

1/1

13 x 15 mm

Wundhaken

Retractors
Separadores
Ecarteurs
Divaricatori



1/2

Kocher
15-315-18-07 -
15-315-40-07
23 cm / 9"

41 x 18 mm
15-315-18-07

61 x 20 mm
15-315-20-07

61 x 25 mm
15-315-25-07

75 x 30 mm
15-315-30-07

75 x 40 mm
15-315-40-07 1/4

Wundhaken

Retractors
Separadores
Ecarteurs
Divaricatori

Wundhaken

Retractors
Separadores
Ecarteurs
Divaricatori

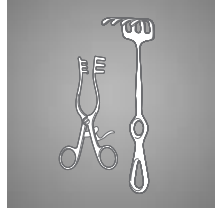

1/2

Kocher-Langenbeck
15-317-01-07 -
15-317-09-07
21,5 cm / 8 4/8"



25 x 6 mm
15-317-01-07

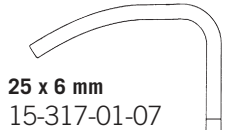

35 x 8 mm
15-317-02-07

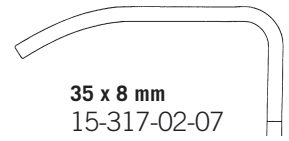

35 x 11 mm
15-317-03-07

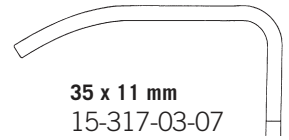

35 x 15 mm
15-317-04-07

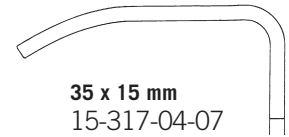

40 x 11 mm
15-317-05-07

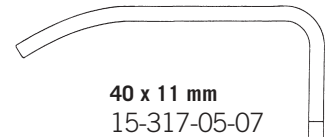

55 x 11 mm
15-317-06-07

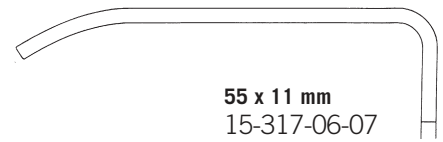

70 x 14 mm
15-317-07-07

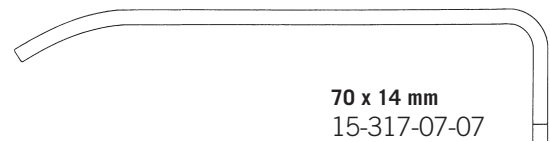

80 x 13 mm
15-317-08-07

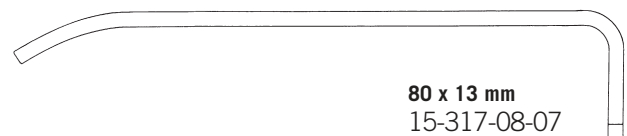

80 x 16 mm
15-317-09-07

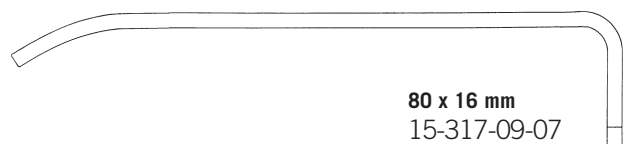

15

1/4

Wundhaken

Retractors
Separadores
Ecarteurs
Divaricatori



1/2

Kocher-Langenbeck
15-319-01-07 -
15-319-08-07
21,5 cm / 8 4/8"

25 x 10 mm
15-319-01-07

40 x 13 mm
15-319-02-07

60 x 13 mm
15-319-03-07

40 x 18 mm
15-319-04-07

60 x 18 mm
15-319-05-07

85 x 18 mm
15-319-06-07

60 x 25 mm
15-319-07-07

85 x 25 mm
15-319-08-07

1/1

Wundhaken

Retractors
Separadores
Ecarteurs
Divaricatori

Wundhaken

Retractors
Separadores
Ecarteurs
Divaricatori

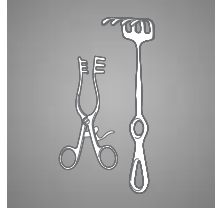

1/2

Zenker
15-321-00-07 -
15-321-05-07



10 x 3 mm
Mini-Zenker
15-321-00-07
18 cm / 7"



35 x 9 mm
15-321-01-07
25 cm / 9 3/4"

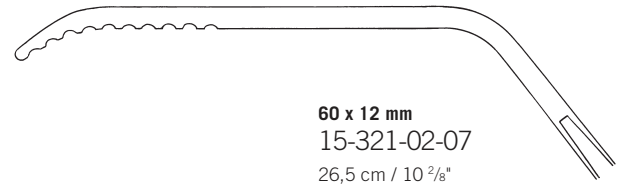

60 x 12 mm
15-321-02-07
26,5 cm / 10 5/8"

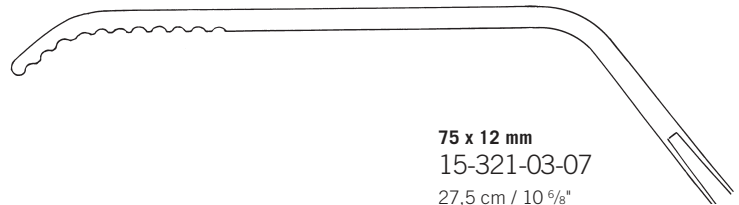

75 x 12 mm
15-321-03-07
27,5 cm / 10 5/8"

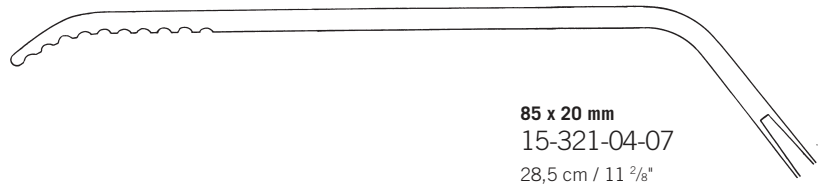

85 x 20 mm
15-321-04-07
28,5 cm / 11 1/8"

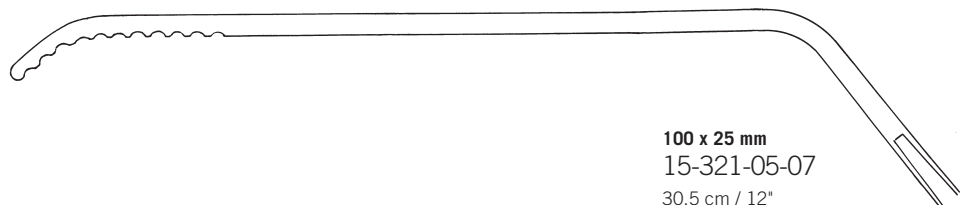

100 x 25 mm
15-321-05-07
30,5 cm / 12"

1/1

15

Wundhaken

Retractors
Separadores
Ecarteurs
Divaricatori



1/2

20 x 12 mm
15-325-01-07

23 x 14 mm
15-325-02-07

1/2

Kocher
15-325-01-07 -
15-325-02-07
21,5 cm / 8 4/8"

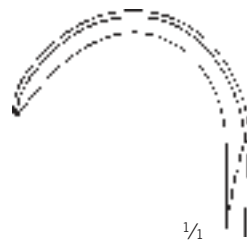

1/2

40 x 15 mm
15-351-02-07
23 cm / 9"

40 x 20 mm
15-351-03-07
23 cm / 9"

1/2

Kocher
15-351-01-07 -
15-351-03-07

1/2

40 x 10 mm
15-351-01-07
22 cm / 8 5/8"

Wundhaken

Retractors
Separadores
Ecarteurs
Divaricatori

Wundhaken

Retractors
Separadores
Ecarteurs
Divaricatori

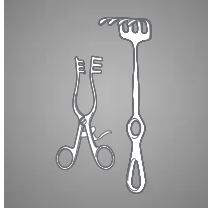

1/2

Middeldorpf
15-361-01-07 -
15-361-03-07

1/1

15 x 17 mm
15-361-01-07
22 cm / 8 5/8"

1/1

22 x 22 mm
15-361-02-07
23 cm / 9"

26 x 31 mm
15-361-03-07
24 cm / 9 4/8"

Fig. 1

15-381-01-01
Kiefer_1
25 x 20 mm
30 x 28 mm



Fig. 2

15-381-02-01
27,5 cm / 10 7/8"
43 x 38 mm
63 x 44 mm

1/2

Richardson-Eastman
15-381-01-01 -
15-381-02-01

15

Wundhaken

Retractors
Separadores
Ecarteurs
Divaricatori



25 x 21 mm
15-391-01-01
23,5 cm / 9 ³/₈"



48 x 22 mm

30 x 29 mm
15-391-02-01
24 cm / 9 ⁴/₈"



62 x 50 mm

38 x 40 mm
15-391-03-01
24 cm / 9 ⁴/₈" ¹/₁

¹/₂

Richardson
15-391-01-01 -
15-391-03-01

¹/₂

Richardson
15-395-24-01
24 cm / 9 ⁴/₈"

¹/₂

Kelly
15-397-26-01
26 cm / 10 ²/₈"

Wundhaken

Retractors
Separadores
Ecarteurs
Divaricatori

Wundhaken

Retractors
Separadores
Ecarteurs
Divaricatori



15

87 x 28 mm
15-401-01-07
25 cm / 9 ⁷/₈"

97 x 31 mm
15-401-02-07
26 cm / 10 ²/₈"

117 x 52 mm
15-401-03-07
26 cm / 10 ²/₈"



1/1

Doyen-Style
15-401-01-07 -
15-401-03-07

1/2

Wundhaken

Retractors
Separadores
Ecarteurs
Divaricatori



1/2

Hösel
15-405-01-07 -
15-405-06-07
26 cm / 10 2/8"

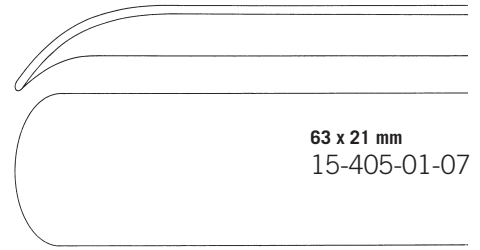

63 x 21 mm
15-405-01-07

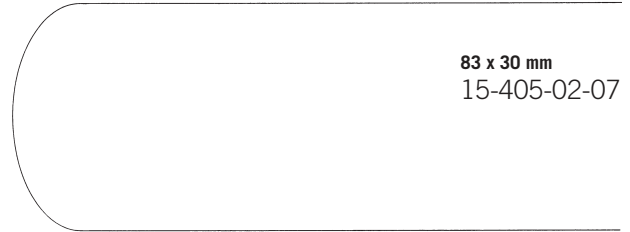

83 x 30 mm
15-405-02-07

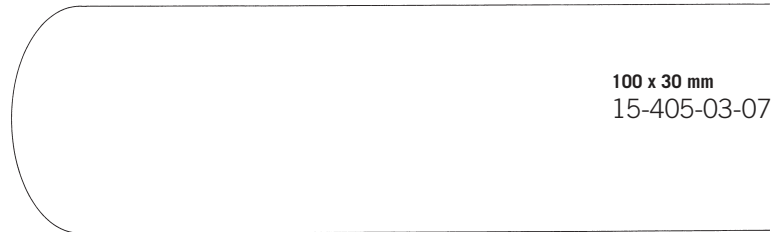

100 x 30 mm
15-405-03-07

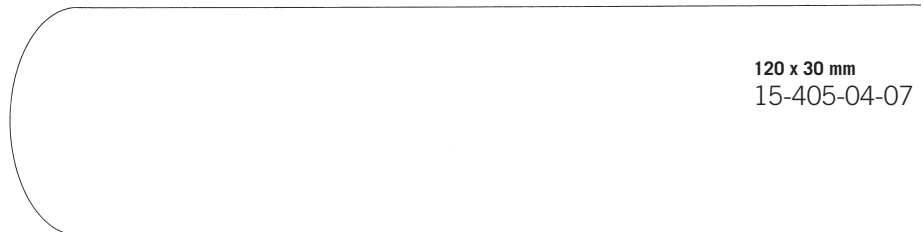

120 x 30 mm
15-405-04-07

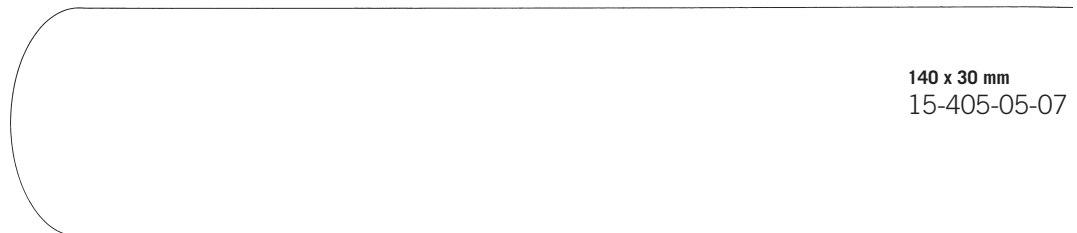

140 x 30 mm
15-405-05-07

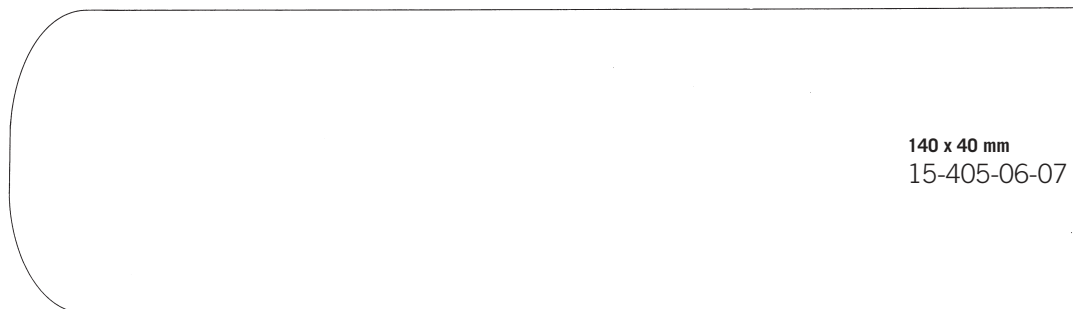

140 x 40 mm
15-405-06-07

1/1

Wundhaken

Retractors
Separadores
Ecarteurs
Divaricatori

Wundhaken

Retractors
Separadores
Ecarteurs
Divaricatori

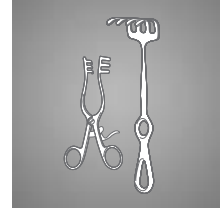

1/2

43 x 45 mm
15-441-01-07
27 cm / 10 5/8"



1/2

Middeldorpf
15-441-01-07 -
15-441-03-07



52 x 50 mm
15-441-02-07
27 cm / 10 5/8"



52 x 70 mm
15-441-03-07
28 cm / 11"

1/4

15

Wundhaken

Retractors
Separadores
Ecarteurs
Divaricatori



1/2

Fritsch
15-452-00-07 -
15-452-05-07

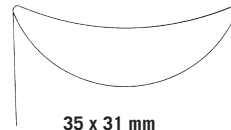

35 x 31 mm
15-452-00-07
23,5 cm / 9 2/8"

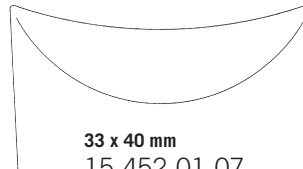

33 x 40 mm
15-452-01-07
24 cm / 9 4/8"

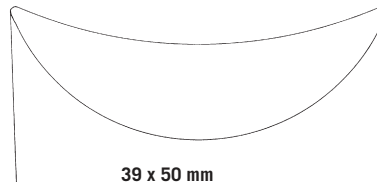

39 x 50 mm
15-452-02-07
25 cm / 9 6/8"

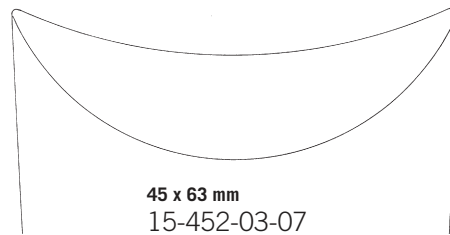

45 x 63 mm
15-452-03-07
25 cm / 9 6/8"

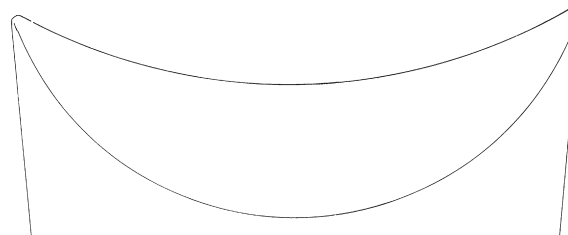

45 x 75 mm
15-452-04-07
25,5 cm / 10"

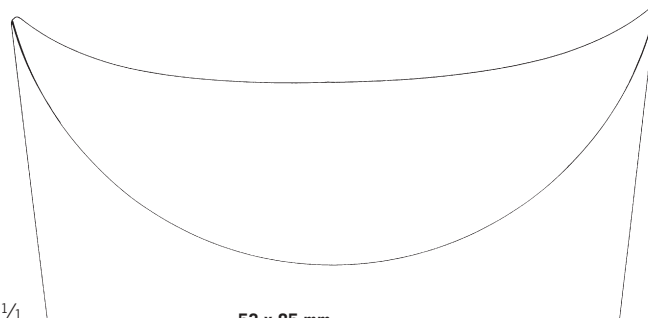

1/1

53 x 85 mm
15-452-05-07
25,5 cm / 10"

Wundhaken

Retractors
Separadores
Ecarteurs
Divaricatori

Wundhaken

Retractors
Separadores
Ecarteurs
Divaricatori



1/2

45 x 88 mm
Doyen
15-461-25-01
24 cm / 9 4/8"



1/2

70 x 25 mm
Kocher
15-469-22-07
23,5 cm / 9 2/8"

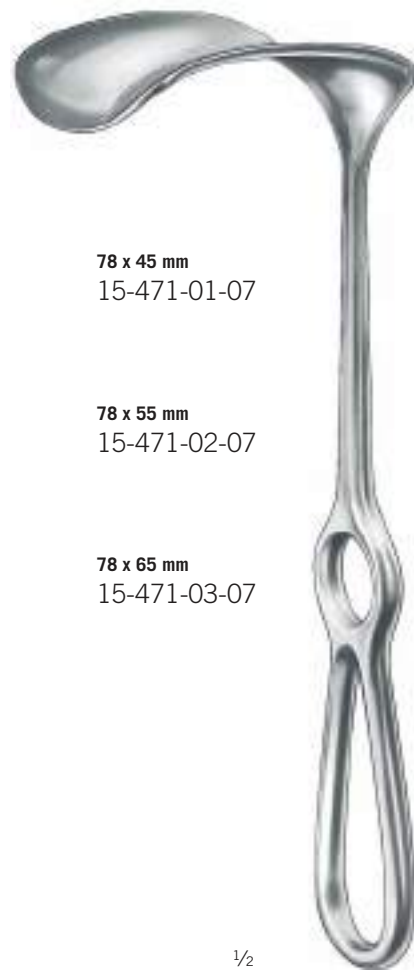

78 x 45 mm
15-471-01-07

78 x 55 mm
15-471-02-07

78 x 65 mm
15-471-03-07

1/2

Kocher
15-471-01-07 -
15-471-03-07
25 cm / 9 7/8"

Wundhaken

Retractors
Separadores
Ecarteurs
Divaricatori

110 x 27 mm
15-501-25-07

1/2

115 x 22 mm
15-505-28-07

115 x 28 mm
15-507-28-07

1/2



1/2

Martin
15-501-25-07
26,5 cm / 10 3/8"



1/2

Simon
15-505-28-07 -
15-507-28-07
28 cm / 11"

Wundhaken

Retractors
Separadores
Ecarteurs
Divaricatori

Wundhaken

Retractors
Separadores
Ecarteurs
Divaricatori



119 x 65 mm
15-537-03-07



108 x 43 mm
15-537-02-07

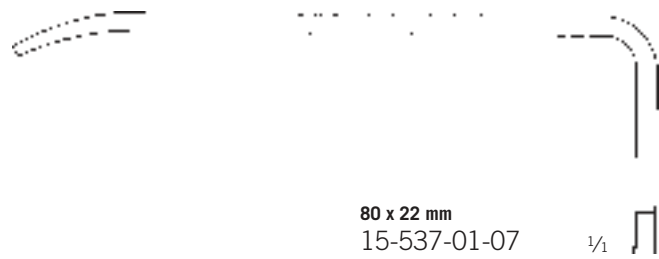

80 x 22 mm
15-537-01-07

1/2



1/2

Coryllos
15-537-01-07 -
15-537-03-07
24 cm / 9 4/8"

15

Scapulahaken

Scapula Retractors
Separadores para escápula
Ecarteurs pour scapula
Divaricatori per scapola



1/2

80 x 54 mm
Davidson
15-545-01-07
19 cm / 7 4/8"



1/2

75 x 93 mm
Davidson
15-545-02-07
18,5 cm / 7 2/8"

Wundhaken

Retractors
Separadores
Ecarteurs
Divaricatori

Wundhaken

Retractors
Separadores
Ecarteurs
Divaricatori

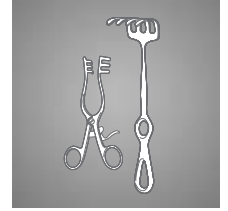

125 x 38 mm

1/1

15



1/2

Sauerbruch
15-551-25-07
25,5 cm / 10 "

Wundhaken

Retractors
Separadores
Ecarteurs
Divaricatori

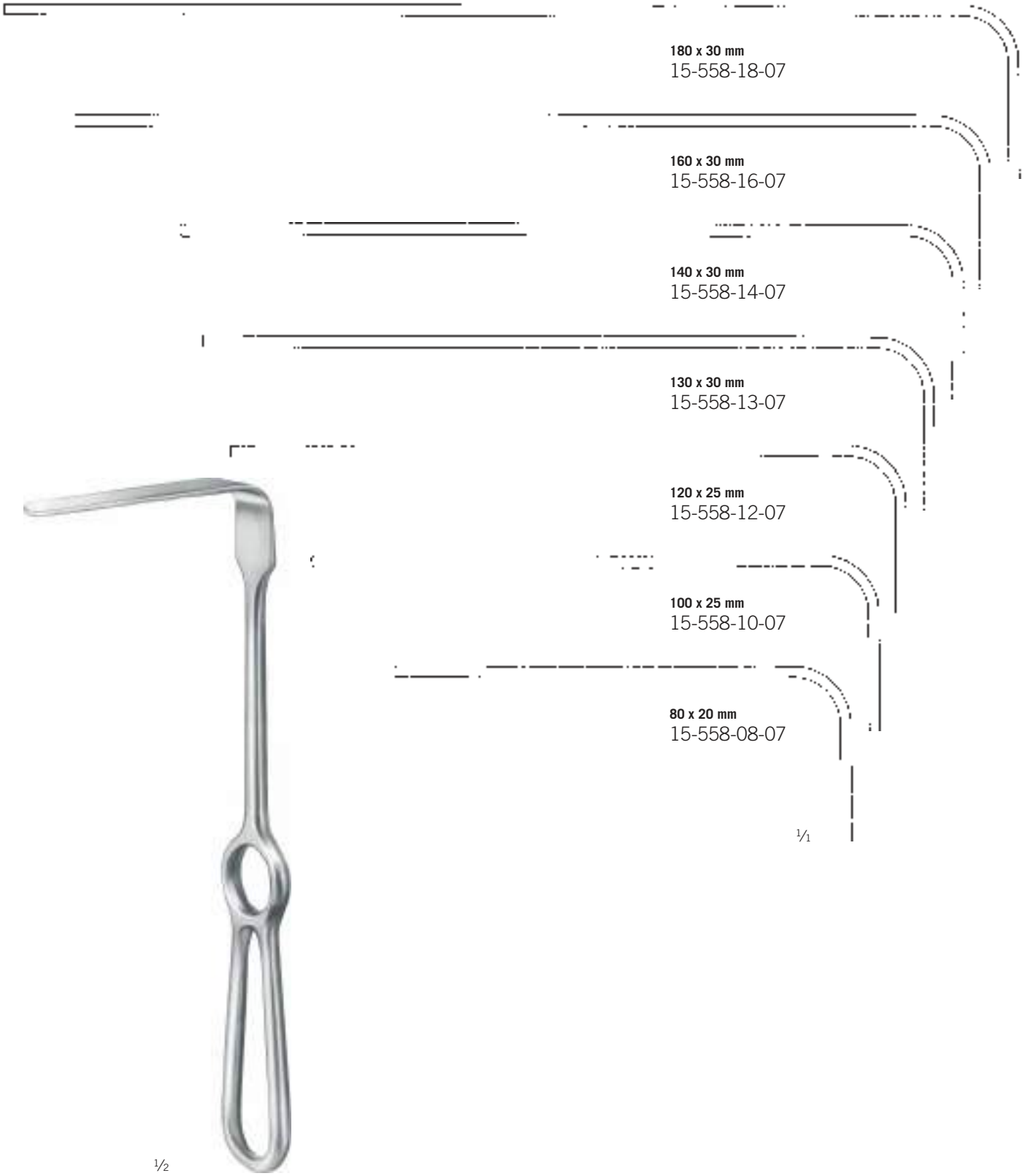

180 x 30 mm
15-558-18-07

160 x 30 mm
15-558-16-07

140 x 30 mm
15-558-14-07

130 x 30 mm
15-558-13-07

120 x 25 mm
15-558-12-07

100 x 25 mm
15-558-10-07

80 x 20 mm
15-558-08-07

1/2

Brunner
15-558-08-07 -
15-558-18-07
25,5 cm / 10 "

Wundhaken

Retractors
Separadores
Ecarteurs
Divaricatori

Wundhaken

Retractors
Separadores
Ecarteurs
Divaricatori



180 x 30 mm
15-559-18-07

160 x 30 mm
15-559-16-07

140 x 25 mm
15-559-14-07

120 x 25 mm
15-559-12-07

100 x 20 mm
15-559-10-07

80 x 20 mm
15-559-08-07



1/2

Brunner
15-559-08-07 -
15-559-18-07
25,5 cm / 10 "

15

1/1

Wundhaken

Retractors
Separadores
Ecarteurs
Divaricatori

45 x 15 mm
15-561-01-07

60 x 23 mm
15-561-02-07

72 x 20 mm
15-561-03-07

1/4



1/2

Sauerbruch
15-561-01-07 -
15-561-03-07
22,5 cm / 8 7/8"

Aortaklappenhaken

Aortic Valve Retractors
Retractor de válvula aórtica
Écarteurs pour valve aortique
Retrattori per valvola aortica

Wundhaken

Retractors
Separadores
Écarteurs
Divaricatori

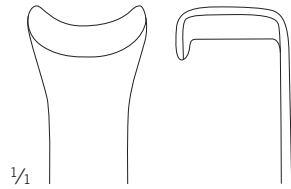
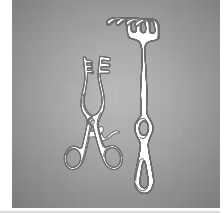

Fig. 1
13 x 16 mm
15-563-01-07
26,5 cm / 10 ³/₈"

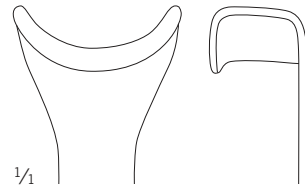

Fig. 2
11 x 22 mm
15-563-02-07
27 cm / 10 ⁵/₈"

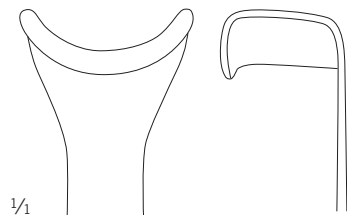

Fig. 3
15 x 23 mm
15-563-03-07
27 cm / 10 ⁵/₈"

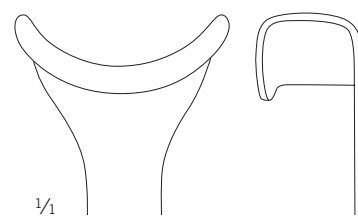

Fig. 4
12 x 28 mm
15-563-04-07
27,5 cm / 10 ⁷/₈"

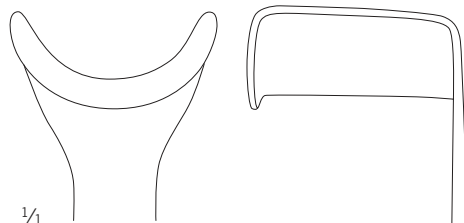

Fig. 5
27 x 27 mm
15-563-05-07
27,5 cm / 10 ⁷/₈"

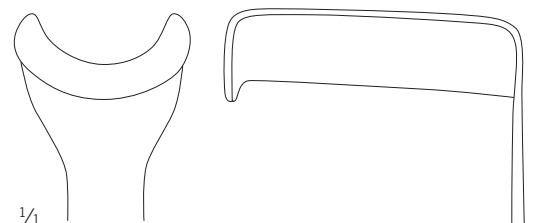

Fig. 6
38 x 24 mm
15-563-06-07
27,5 cm / 10 ⁷/₈"



1/2

Ross
15-563-01-07 -
15-563-06-07

flexibler Schaft
flexible shaft
vástagó flexible
tige flexible
asta flessibile

15

Aortaklappenhaken

Aortic Valve Retractors
Retractor de válvula aórtica
Écarteurs pour valve aortique
Retrattori per valvola aortica

Sic

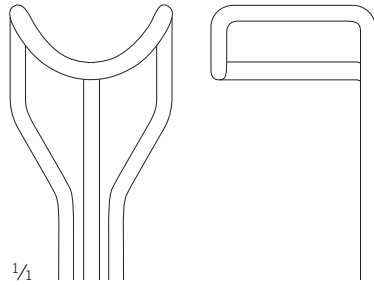

Fig. 1
17 x 21 mm
15-564-01-07

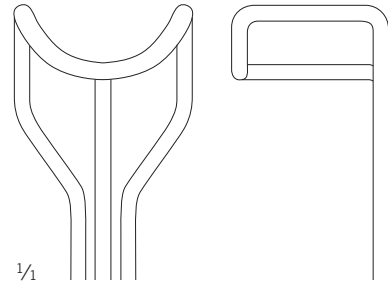

Fig. 2
16 x 23 mm
15-564-02-07

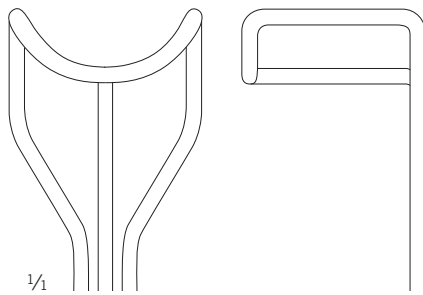

Fig. 3
15-564-03-07
20 x 25 mm

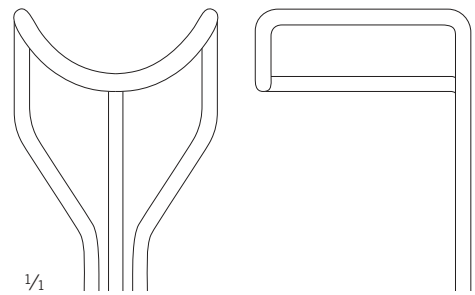

Fig. 4
15-564-04-07
24 x 27 mm

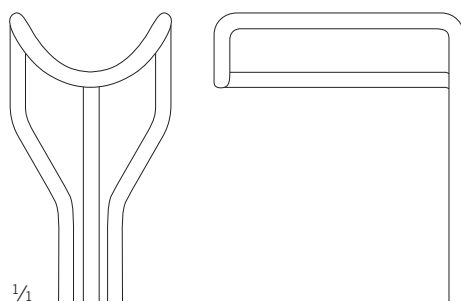

Fig. 5
15-564-05-07
28 x 20 mm

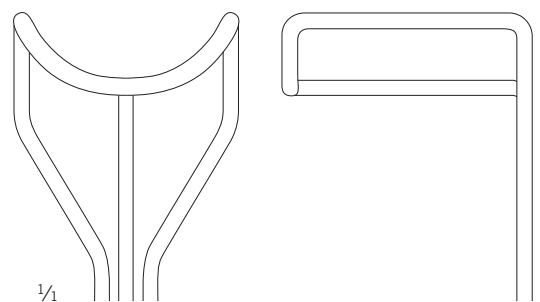

Fig. 6
15-564-06-07
28 x 29 mm



Borowski
15-564-01-07 -
15-564-06-07
27 cm / 10 5/8"

Wundhaken

Retractors
Separadores
Ecarteurs
Divaricatori

Wundhaken

Retractors
Separadores
Ecarteurs
Divaricatori

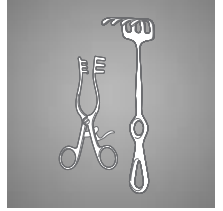

1/2

Polloson
15-577-27-07
29 cm / 11 3/8"

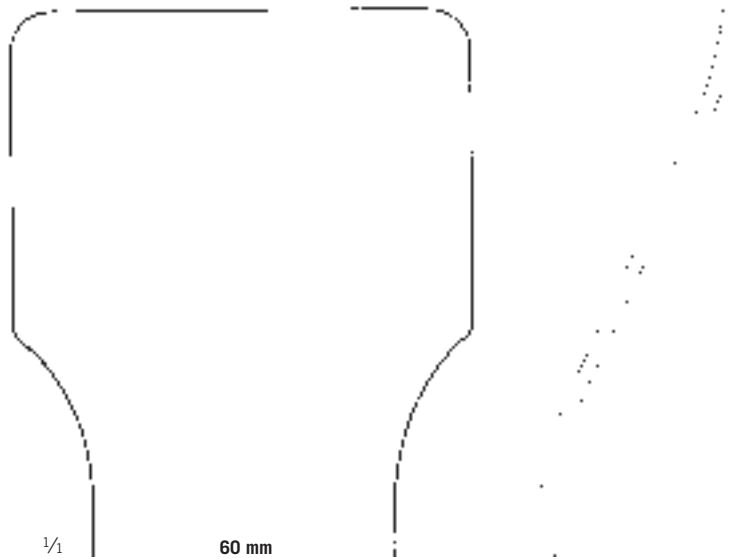

1/1

60 mm

15

Wundhaken

Retractors
Separadores
Ecarteurs
Divaricatori



1/2

Polloson
15-579-27-07
26 cm / 10 4/8"

Wundhaken

Retractors
Separadores
Ecarteurs
Divaricatori

Wundhaken

Retractors
Separadores
Ecarteurs
Divaricatori

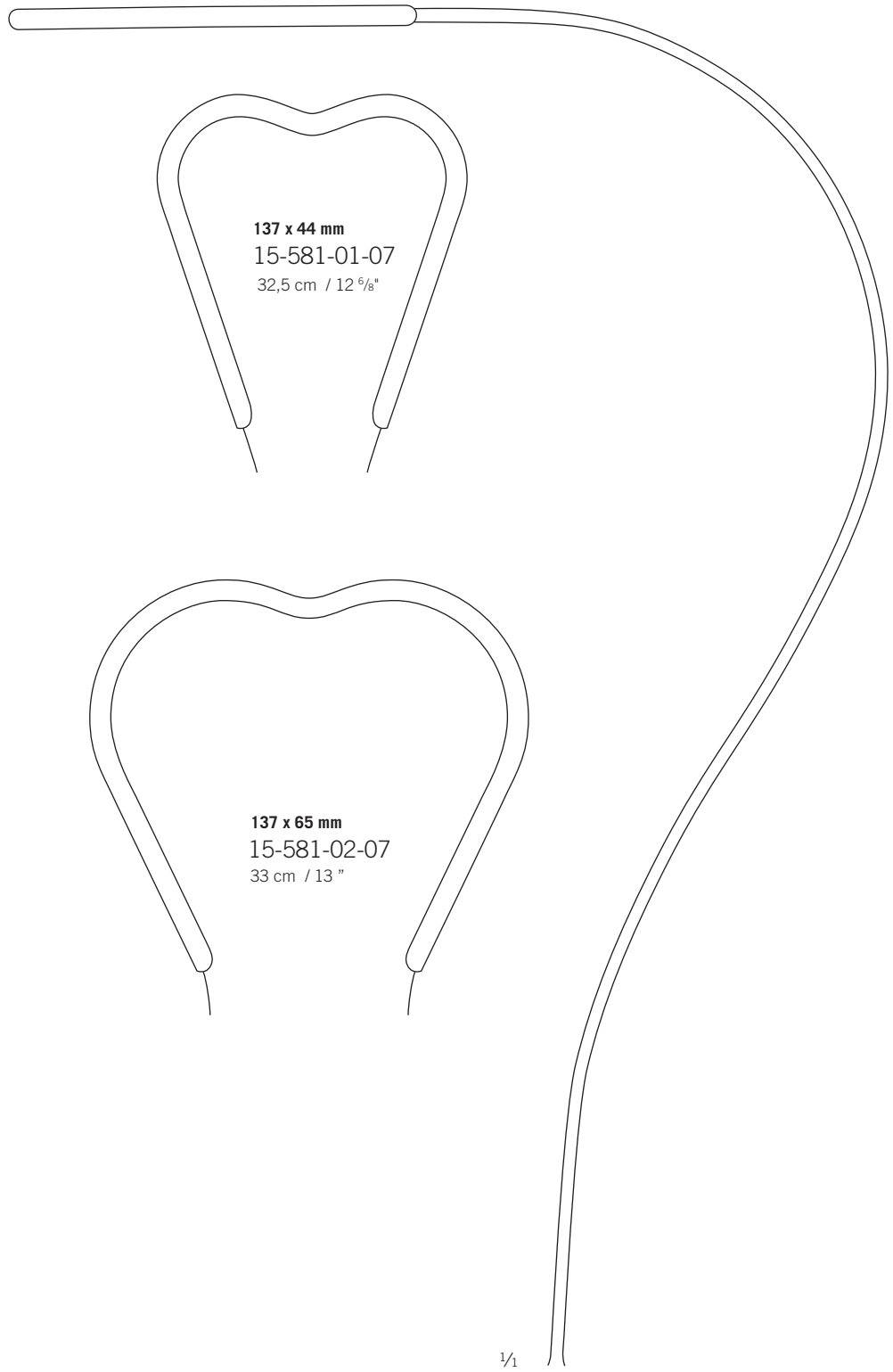
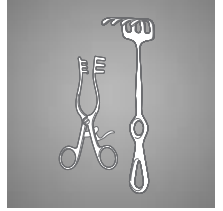

137 x 44 mm
15-581-01-07
32,5 cm / 12 5/8"

137 x 65 mm
15-581-02-07
33 cm / 13"

1/2

1/1

Harrington
15-581-01-07 -
15-581-02-07

15

Wundhaken

Retractors
Separadores
Ecarteurs
Divaricatori



1/2

19 mm
Deaver
15-591-01-07
18 cm / 7 1/8"

22 mm
Deaver
15-591-02-07
21,5 cm / 8 4/8"

25 mm
Deaver
15-591-03-07
26 cm / 10 2/8"

25 mm
Deaver
15-591-04-07
30,5 cm / 12"

25 mm
Deaver
15-591-05-07
33,5 cm / 13 3/8"

25 mm
Deaver
15-591-06-07
34,5 cm / 13 5/8"

Wundhaken

Retractors
Separadores
Ecarteurs
Divaricatori

Wundhaken

Retractors
Separadores
Ecarteurs
Divaricatori



1/2

38 mm
Deaver
15-591-07-07
32 cm / 12 5/8"



50 mm
Deaver
15-591-08-07
31,5 cm / 12 3/8"



75 mm
Deaver
15-591-09-07
31,5 cm / 12 3/8"

15

Wundhaken

Retractors
Separadores
Ecarteurs
Divaricatori



Deaver
15-592-04-07 -
15-592-10-07

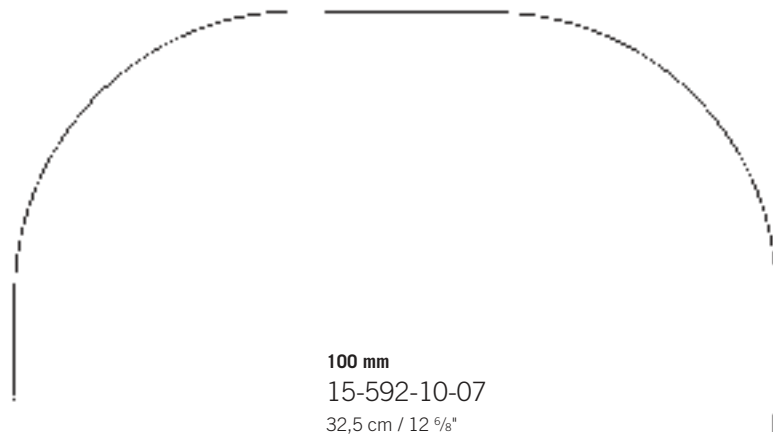
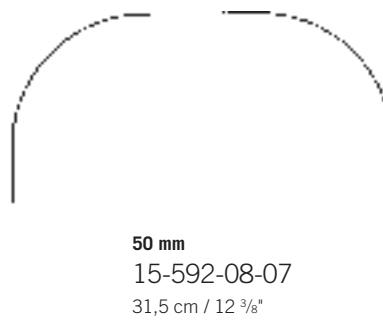
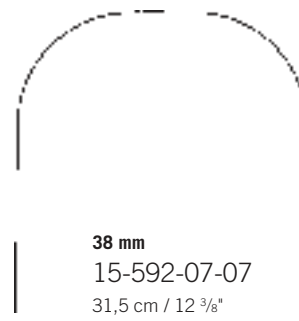

Atriumhaken

Atrium Retractors
Separadores para atrio
Ecarteurs pour atrium
Divaricatori per atrio

Wundhaken

Retractors
Separadores
Ecarteurs
Divaricatori

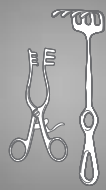

Sic



1/2

48 x 48 mm
Cooley
15-593-01-01
25 cm / 9 7/8"
rechts
right
derecho
droit
destra



1/2

48 x 48 mm
Cooley
15-593-02-01
25 cm / 9 7/8"
rechts, gerieft
right, serrated
derecho, estriado
droit, avec stries
destra, con striatura



1/2

30 x 48 mm
Cooley
15-593-03-01
27,5 cm / 10 7/8"
links
left
izquierdo
gauche
sinistra

15

Wundhaken

Retractors
Separadores
Ecarteurs
Divaricatori

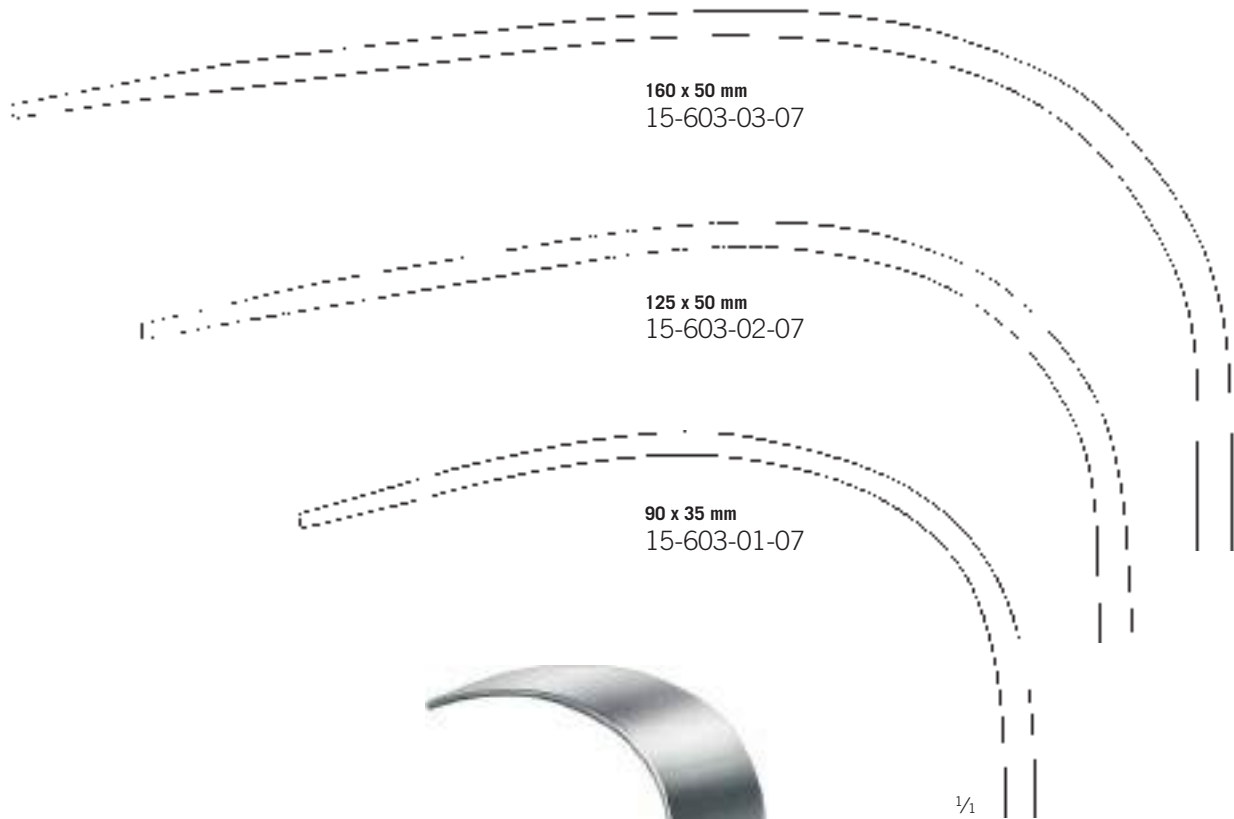

160 x 50 mm
15-603-03-07

125 x 50 mm
15-603-02-07

90 x 35 mm
15-603-01-07

1/2

Mikulicz
15-603-01-07 -
15-603-03-07
25 cm / 9 7/8"

Wundhaken

Retractors
Separadores
Ecarteurs
Divaricatori

Wundhaken

Retractors
Separadores
Ecarteurs
Divaricatori

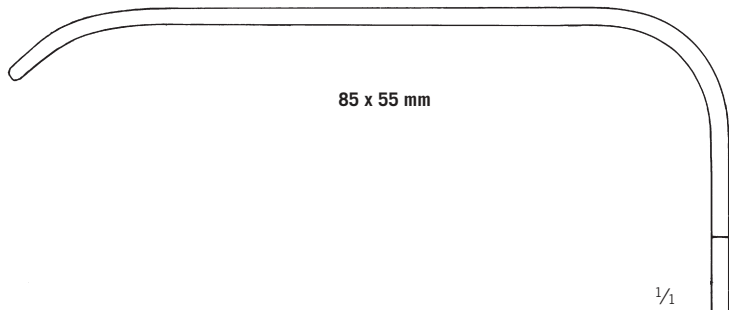
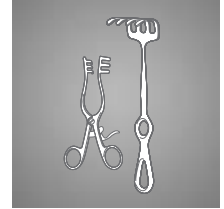

85 x 55 mm

1/4

205 x 38 mm
15-611-01-07
27,5 cm / 10 7/8"

1/4



1/2

Mikulicz
15-607-26-07
26 cm / 10 1/8"



1/2

Kelly
15-611-01-07 -
15-611-02-07

210 x 57 mm
15-611-02-07
28 cm / 11"



15

Pelvishaken

Pelvis Retractors

Separadores para pelvis

Ecarteurs pour pelvis

Divaricatori per pelvis



1/2

St. Marks
15-615-01-01 -
15-615-03-01

35 x 45 mm

130 x 60 mm
15-615-01-01
26 cm / 10 7/8"

60 x 45 mm

180 x 60 mm
15-615-02-01
23,5 cm / 9 2/8"

60 x 45 mm

180 x 60 mm
15-615-03-01
28 cm / 11"

Bauchspatel

Abdominal Spatulas
Espátulas abdominales
Spatules abdominales
Spatole addominali

Wundhaken

Retractors
Separadores
Ecarteurs
Divaricatori

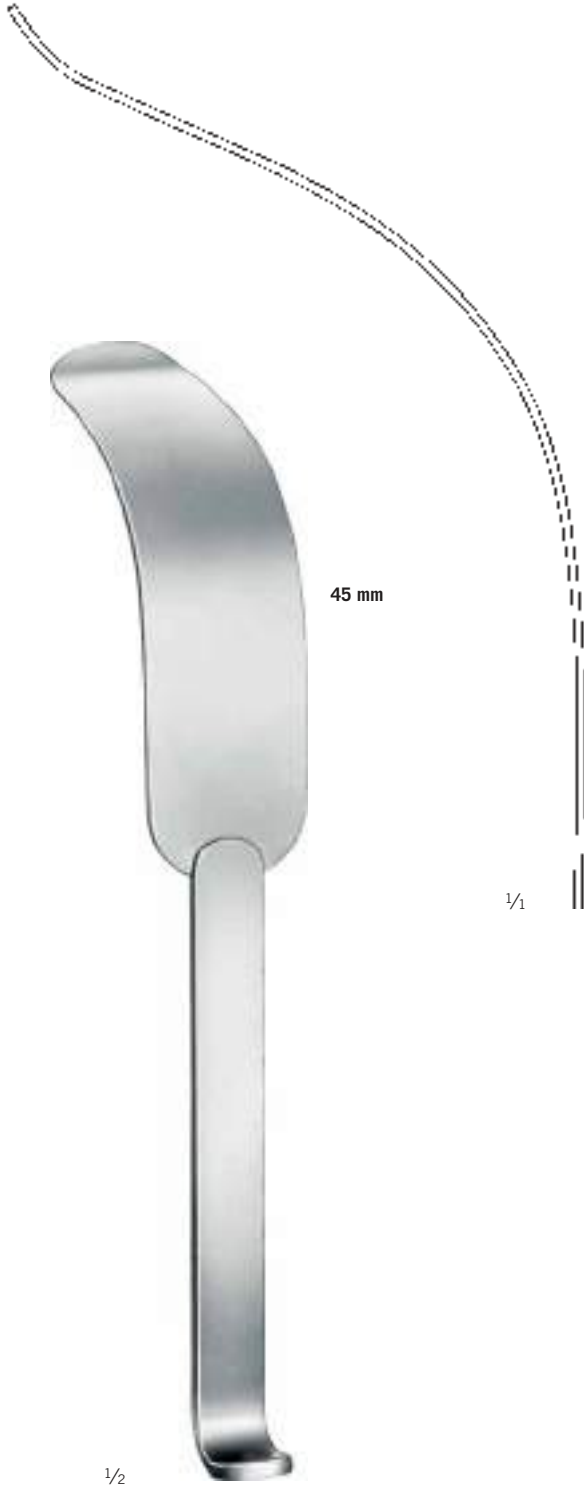
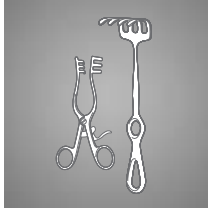

Kümmel
15-621-28-07
31 cm / 12 2/8"



Kader
15-623-20-07 -
15-623-40-07
28 cm / 11"

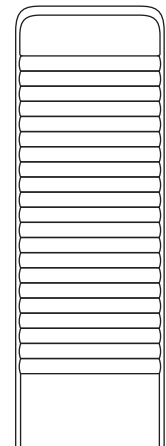

20 mm
15-623-20-07

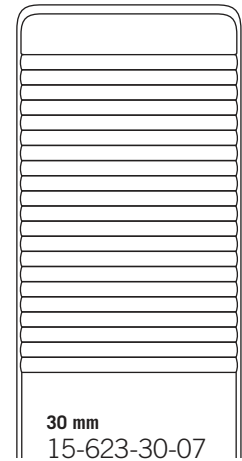

30 mm
15-623-30-07

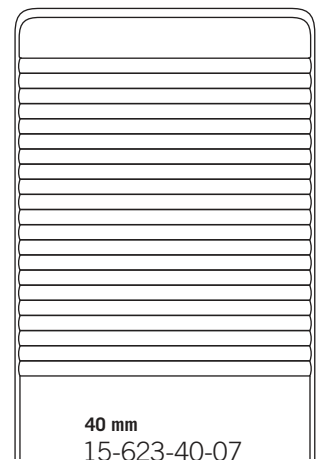

40 mm
15-623-40-07

15

Wundhaken

Retractors
Separadores
Ecarteurs
Divaricatori



1/2

Collin-Hartmann
15-652-01-07
15 cm / 5 7/8"

50 x 35 mm
15-652-01-01
35 x 29 mm

1/1



1/2

Roux
15-655-00-01 -
15-655-03-01



1/1

Fig. 1 - 3
15-655-00-01
17 cm / 6 5/8"
Satz
Set

Fig. 1

22 x 21 mm
27 x 29 mm
15-655-01-01
14,5 cm / 5 6/8"

Fig. 2

25 x 26 mm
30 x 38 mm
15-655-02-01
16 cm / 6 2/8"

Fig. 3

28 x 29 mm
33 x 43 mm
15-655-03-01
17 cm / 6 5/8"

Wundhaken

Retractors
Separadores
Ecarteurs
Divaricatori

Wundhaken

Retractors
Separadores
Ecarteurs
Divaricatori

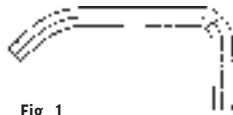
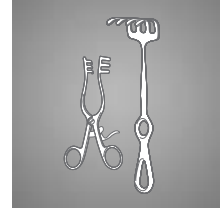

Fig. 1
26 x 10 mm / 30 x 13 mm

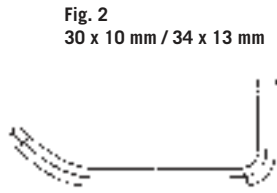

Fig. 2
30 x 10 mm / 34 x 13 mm

Farabeuf
15-663-00-07
12 cm / 4 5/8"

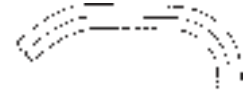

Fig. 1
23 x 16 mm / 26 x 16 mm

Fig. 2
27 x 16 mm / 30 x 16 mm

Farabeuf
15-665-00-07
15,5 cm / 6 1/8"



6 x 7 mm
7 x 8 mm

Roux-Mini
15-667-06-01
14,5 cm / 5 5/8"



17 x 17 mm

24 x 21 mm

Roux-Baby
15-669-13-01
12,5 cm / 4 7/8"

15

Wundhaken

Retractors
Separadores
Ecarteurs
Divaricatori

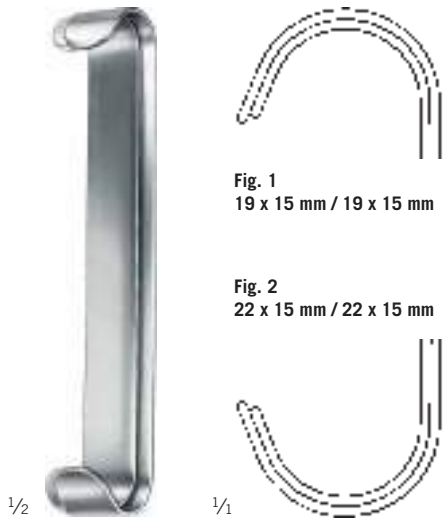

Fig. 1
19 x 15 mm / 19 x 15 mm

Fig. 2
22 x 15 mm / 22 x 15 mm

Parker
15-673-01-07
14 cm / 5 4/8"

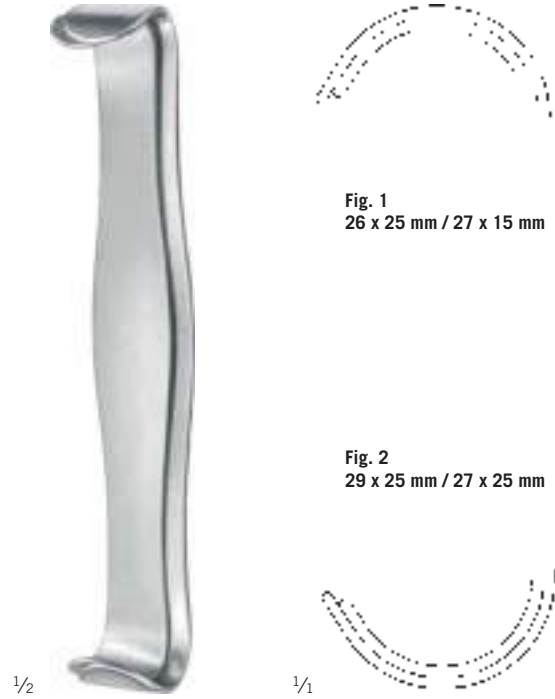

Fig. 1
26 x 25 mm / 27 x 15 mm

Fig. 2
29 x 25 mm / 27 x 25 mm

Parker
15-673-02-07
18,5 cm / 7 3/8"



Fig. 1
21 x 24 mm
Fig. 2
21 x 24 mm

Fig. 1
68 x 24 mm
Fig. 2
72 x 24 mm

Parker-Mott
15-675-00-07
16 cm / 6 2/8"

Wundhaken

Retractors
Separadores
Ecarteurs
Divaricatori

Wundhaken

Retractors
Separadores
Ecarteurs
Divaricatori

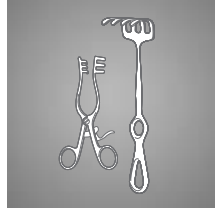

Fig. 1
42 x 13 mm / 42 x 26 mm



Fig. 2
47 x 13 mm / 46 x 26 mm

1/2

1/1

Mathieu
15-683-00-07
20 cm / 7 7/8"

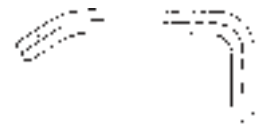

Fig. 1
21 x 15 mm / 40 x 15 mm

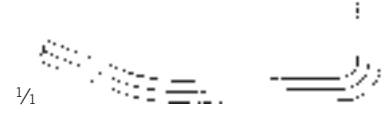
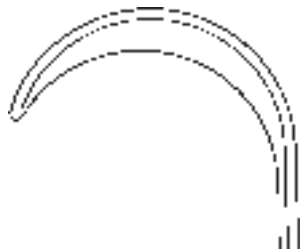

Fig. 2
25 x 15 mm / 45 x 15 mm

1/2

1/1

Parker-Langenbeck
15-687-00-07
21,5 cm / 8 4/8"



26 x 30 mm

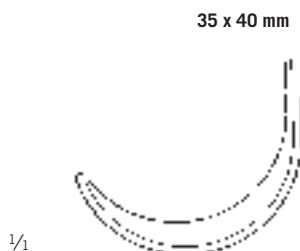

35 x 40 mm

1/2

1/1

Goelet
15-695-00-01
19 cm / 7 4/8"

15

Wundspreizer, selbsthaltend

Wound Spreaders, self-retaining

Separadores autoestáticos

Ecarteurs autostatiques

Divaricatori autostatici



1/2

Finsen
15-700-05-07 -
15-703-07-07

1/1

15-700-05-07

5 cm / 2"

scharf
sharp
agudo
pointu
acuto



2:3



16 mm

15-701-05-07

5 cm / 2"

stumpf
blunt
romo
mousse
smusso



2:3



16 mm

15-702-07-07

7 cm / 2 5/8"

scharf
sharp
agudo
pointu
acuto



3:4



20 mm

15-703-07-07

7 cm / 2 5/8"

stumpf
blunt
romo
mousse
smusso



3:4



20 mm

1/1

15-704-07-07

mit Stellschraube, scharf
with adjusting screw, sharp
con tornillo de ajuste, agudo
avec vis d'ajustage, pointu
con vite di arresto, acuto



3:4



30 mm

15-705-07-07

mit Stellschraube, stumpf
with adjusting screw, blunt
con tornillo de ajuste, romo
avec vis d'ajustage, mousse
con vite di arresto, smusso



3:4



30 mm

1/2

Finsen-Martin
15-704-07-07 -
15-705-07-07
7,5 cm / 3"

Wundspreizer, selbsthaltend

Wound Spreaders, self-retaining

Separadores autoestáticos

Ecarteurs autostatiques

Divaricatori autostatici

Wundhaken

Retractors

Separadores

Ecarteurs

Divaricatori

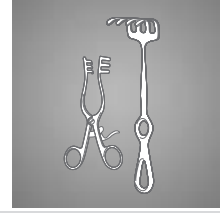

1/1

scharf
sharp
agudo
pointu
acuto



3:3



25 mm

Buckley
15-710-06-07
6 cm / 2 3/8"



1/1

15-708-04-07

mit Stellschraube, scharf
with adjusting screw, sharp
con tornillo de ajuste, agudo
avec vis d'ajustage, pointu
con vite di arresto, acuto



1/2



3:3



16 mm

Logan
15-708-04-07
4 cm / 1 3/8"



1/2



1/1

stumpf
blunt
romo
mousse
smusso



4:4



24 mm

15-717-10-07
10 cm / 3 7/8"

15

Wundspreizer, selbsthaltend

Wound Spreaders, self-retaining

Separadores autoestáticos

Ecarteurs autostatiques

Divaricatori autostatici

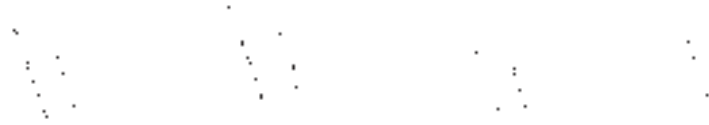

1/1



15-714-07-07

7 cm / 2 6/8"

scharf
sharp
agudo
pointu
acuto



4:4



55 mm

15-714-10-07

10 cm / 3 7/8"

scharf
sharp
agudo
pointu
acuto



4:4



70 mm

15-715-07-07

7 cm / 2 6/8"

stumpf
blunt
romo
mousse
smusso



4:4



55 mm

15-715-10-07

10 cm / 3 7/8"

stumpf
blunt
romo
mousse
smusso



4:4



70 mm

1/2

Alm

15-714-07-07 -
15-715-10-07

mit Stellschraube
with adjusting screw
con tornillo de ajuste
avec vis d'ajustage
con vite di arresto

┌

┐

┌

┐

┌

┐

1/1



15-723-10-07

mit Stellschraube, stumpf
with adjusting screw, blunt
con tornillo de ajuste, romo
avec vis d'ajustage, mousse
con vite di arresto, smusso



3:3



47 mm

15-723-20-07

mit Stellschraube, scharf
with adjusting screw, sharp
con tornillo de ajuste, agudo
avec vis d'ajustage, pointu
con vite di arresto, acuto



3:3



47 mm

1/2

Jansen

15-723-10-07-
15-723-20-07

10 cm / 3 7/8"

Wundspreizer, selbsthaltend

Wound Spreaders, self-retaining

Separadores autoestáticos

Ecarteurs autostatiques

Divaricatori autostatici

Wundhaken

Retractors

Separadores

Ecarteurs

Divaricatori

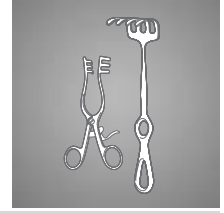

1/2

Scalp-Contour
15-725-14-07 -
15-727-14-07
13,5 cm / 5 3/8"

1/1

15-725-14-07

13,5 cm / 5 3/8"

scharf
sharp
agudo
pointu
acuto



3:4



55 mm

15-727-14-07

13,5 cm / 5 3/8"

stumpf
blunt
romo
mousse
smusso



3:4



55 mm



1/2

Anderson-Adson
15-732-20-07
19 cm / 7 4/8"

1/1

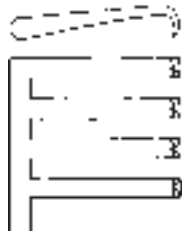

scharf
sharp
agudo
pointu
acuto



4:4



84 mm

Wundspreizer, selbsthaltend

Wound Spreaders, self-retaining

Separadores autoestáticos

Ecarteurs autostatiques

Divaricatori autostatici

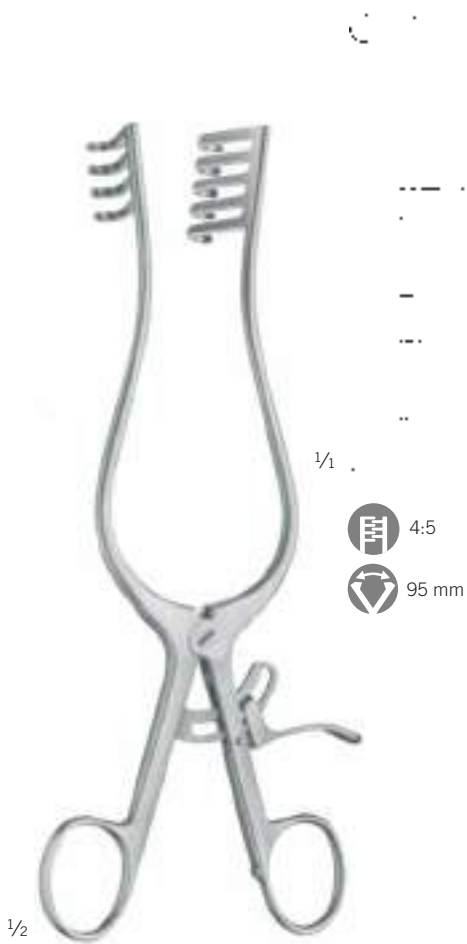

Travers
15-733-21-07

21,5 cm / 8 4/8"

stumpf
blunt
romo
mousse
smusso

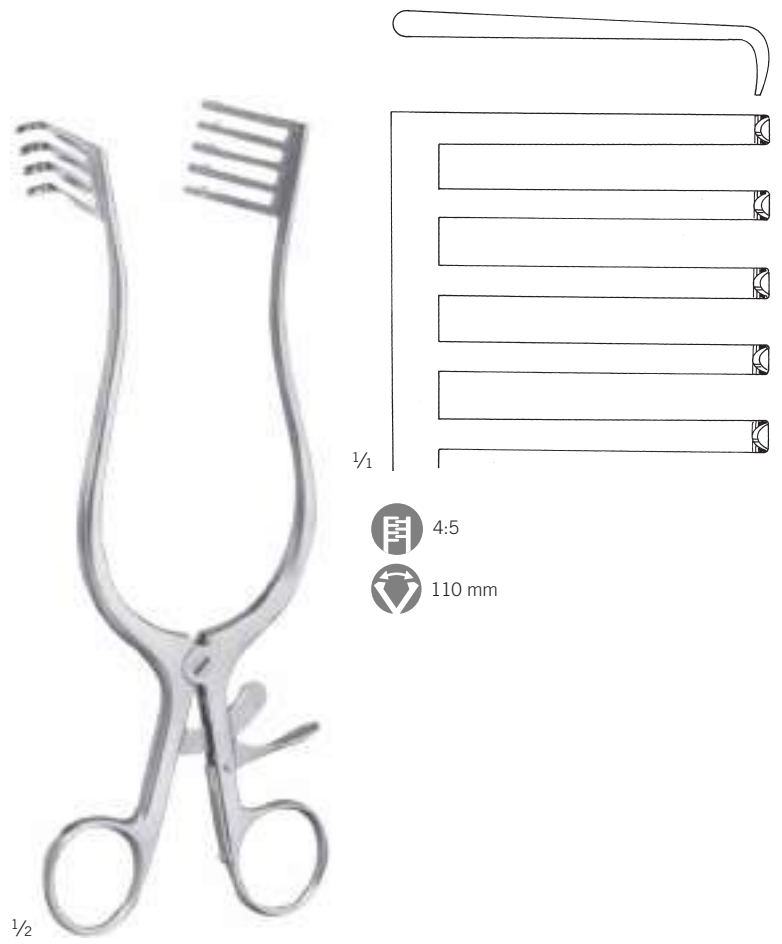

Norfolk-Norwich
15-733-22-07

22 cm / 8 5/8"

stumpf
blunt
romo
mousse
smusso

Wundspreizer, selbsthaltend

Wound Spreaders, self-retaining

Separadores autoestáticos

Ecarteurs autostatiques

Divaricatori autostatici

Wundhaken

Retractors

Separadores

Ecarteurs

Divaricatori

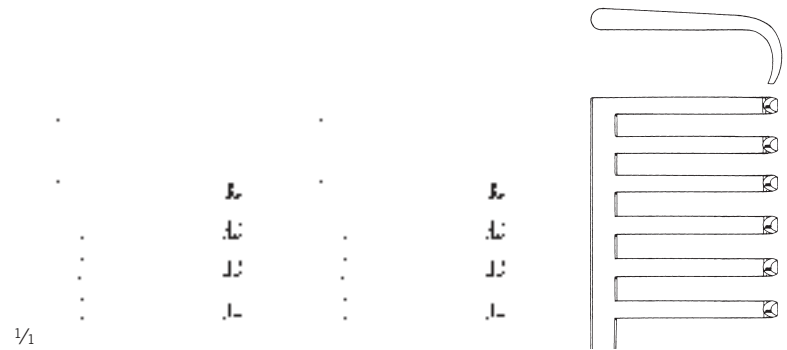
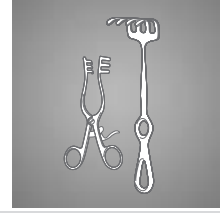

scharf sharp agudo pointu acuto		15-734-20-07	15-734-24-07	15-734-26-07
		20 cm / 7 7/8"	24 cm / 9 4/8"	25,5 cm / 10"
		3:4	3:4	5:6
		90 mm	90 mm	90 mm

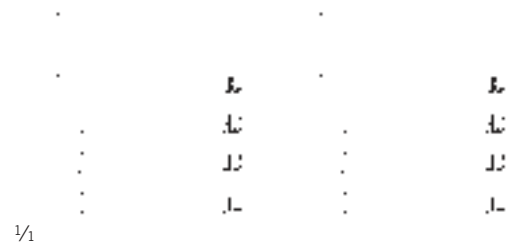

halbscharf semi-sharp semi-agudo semi-pointu semi acuto		15-734-21-07	15-736-24-07
		20 cm / 7 7/8"	24 cm / 9 4/8"
		3:4	3:4
		90 mm	90 mm

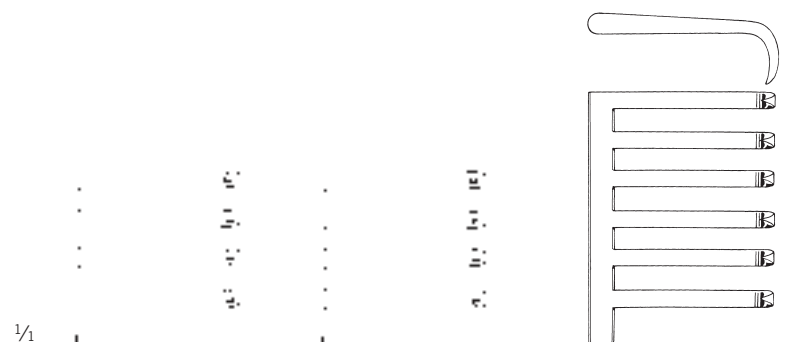

stumpf blunt romo mousse smusso		15-735-20-07	15-735-24-07	15-735-26-07
		20 cm / 7 7/8"	24 cm / 9 4/8"	25,5 cm / 10"
		3:4	3:4	5:6
		90 mm	90 mm	90 mm



1/2

Weitlaner
15-734-20-07 -
15-735-26-07

15

Wundspreizer, selbsthaltend

Wound Spreaders, self-retaining

Separadores autoestáticos

Ecarteurs autostatiques

Divaricatori autostatici



1/1

15-736-26-07

26 cm / 10 2/8"

scharf
sharp
agudo
pointu
acuto



3:4



100 mm



1/1

15-736-27-07

26 cm / 10 2/8"

halbscharf
semi-sharp
semi-agudo
semi-pointu
semi acuto



3:4



100 mm

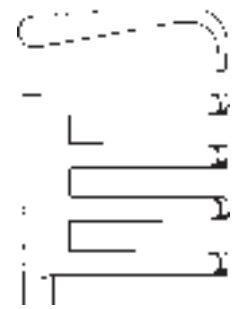

1/1

15-737-26-07

26 cm / 10 2/8"

stumpf
blunt
romo
mousse
smusso



3:4



100 mm



1/1

15-738-26-07

29 cm / 11 3/8"

scharf
sharp
agudo
pointu
acuto



6:6



110 mm

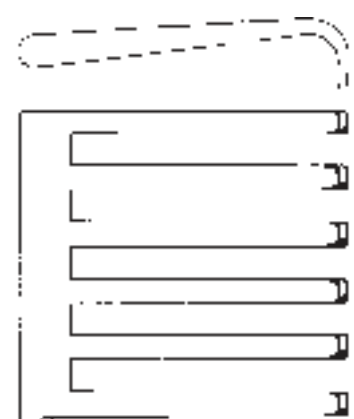

1/1

15-739-26-07

29 cm / 11 3/8"

stumpf
blunt
romo
mousse
smusso



6:6



110 mm



1/2

Adson

15-736-26-07 -
15-739-26-07

Wundspreizer, selbsthaltend

Wound Spreaders, self-retaining

Separadores autoestáticos

Ecarteurs autostatiques

Divaricatori autostatici

Wundhaken

Retractors

Separadores

Ecarteurs

Divaricatori

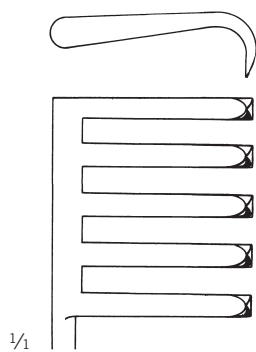
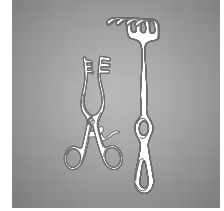

15-738-25-07
scharf
sharp
agudo
pointu
acuto

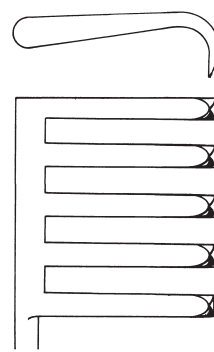

15-738-27-07
halbscharf
semi-sharp
semi-agudo
semi-pointu
semi acuto

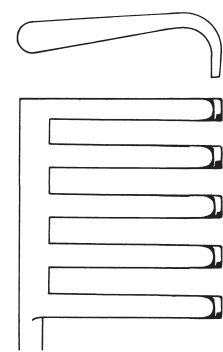

15-739-25-07
stumpf
blunt
romo
mousse
smusso

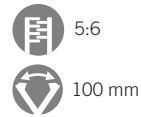

1/2

15-738-25-07 -
15-739-25-07
25,5 cm / 10"

Wundspreizer, selbsthaltend

Wound Spreaders, self-retaining

Separadores autoestáticos

Ecarteurs autostatiques

Divaricatori autostatici



1/2

15-740-13-07 -
15-741-13-07

13 cm / 5 1/8"

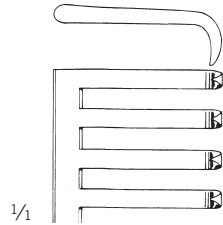

1/1

15-740-13-07

scharf
sharp
agudo
pointu
acuto



3:4



43 mm

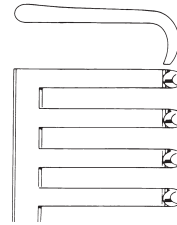

15-741-13-07

stumpf
blunt
romo
mousse
smusso



3:4



43 mm



1/2

Weitlaner
15-747-10-07 -
15-749-10-07

11 cm / 4 3/8"

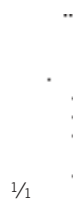

1/1

15-747-10-07

scharf
sharp
agudo
pointu
acuto



2:3



40 mm

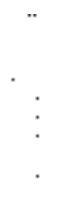

15-748-10-07

halbscharf
semi-sharp
semi-agudo
semi-pointu
semi acuto



2:3



40 mm



15-749-10-07

stumpf
blunt
romo
mousse
smusso



2:3



40 mm

Wundspreizer, selbsthaltend

Wound Spreaders, self-retaining

Separadores autoestáticos

Ecarteurs autostatiques

Divaricatori autostatici

Wundhaken

Retractors

Separadores

Ecarteurs

Divaricatori

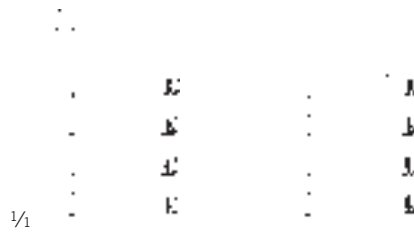
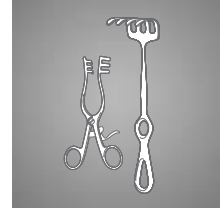

scharf sharp agudo pointu acuto		15-750-13-07	15-750-16-07
		13,5 cm / 5 3/8"	16 cm / 6 2/8"
		43 mm	83 mm
		3:4	3:4

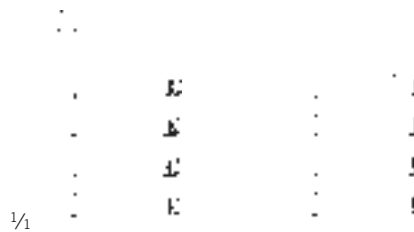

halbscharf semi-sharp semi-agudo semi-pointu semi acuto		15-750-14-07	15-750-17-07
		13,5 cm / 5 3/8"	16 cm / 6 2/8"
		43 mm	83 mm
		3:4	3:4

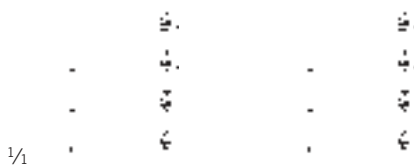

stumpf blunt romo mousse smusso		15-751-13-07	15-751-16-07
		13,5 cm / 5 3/8"	16 cm / 6 2/8"
		43 mm	83 mm
		3:4	3:4



1/2

Weitlaner
15-750-13-07 -
15-751-16-07

15

Wundspreizer, selbsthaltend

Wound Spreaders, self-retaining

Separadores autoestáticos

Ecarteurs autostatiques

Divaricatori autostatici



1/2

Weitlaner-Wullstein

15-752-13-07 -

15-753-13-07

13 cm / 5 1/8"

1/1

15-752-13-07

scharf
sharp
agudo
pointu
acuto



3:3



40 mm

15-753-13-07

stumpf
blunt
romo
mousse
smusso



3:3



40 mm



1/2

Mollison

15-754-15-07

15,5 cm / 6 1/8"

1/1

scharf
sharp
agudo
pointu
acuto



4:4



80 mm

Wundspreizer, selbsthaltend

Wound Spreaders, self-retaining

Separadores autoestáticos

Ecarteurs autostatiques

Divaricatori autostatici

Wundhaken

Retractors

Separadores

Ecarteurs

Divaricatori

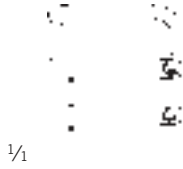
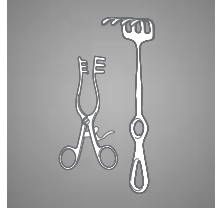

15-755-13-07

stumpf
blunt
romo
mousse
smusso



2:2



37 mm

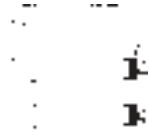

15-756-13-07

scharf
sharp
agudo
pointu
acuto



2:2



37 mm

1/2

Plester

15-755-13-07 -

15-756-13-07

13 cm / 5 1/8"

15



1/2

Plester

15-757-11-07

10,5 cm / 4 1/8"

stumpf
blunt
romo
mousse
smusso



37 mm



1/2

Plester

15-759-11-07

10,5 cm / 4 1/8"

stumpf
blunt
romo
mousse
smusso



37 mm

Wundspreizer, selbsthaltend

Wound Spreaders, self-retaining

Separadores autoestáticos

Ecarteurs autostatiques

Divaricatori autostatici

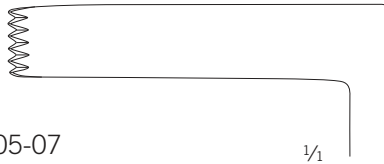

15-762-05-07

50 x 10 mm

Valve links voll
Blade left full
Valva a la izquierda plena
Valve sur le bras à gauche
Valva sul braccio sinistro

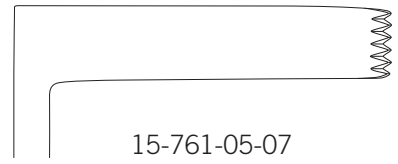

15-761-05-07

50 x 10 mm

Valve rechts voll
Blade rightfull
Valva a la derecha plena
Valve sur le bras à droite
Valva sul braccio destro

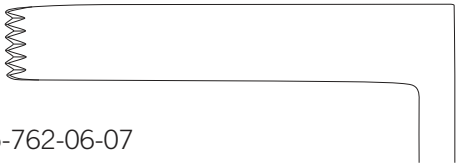

15-762-06-07

60 x 10 mm

Valve links voll
Blade left full
Valva a la izquierda plena
Valve sur le bras à gauche
Valva sul braccio sinistro

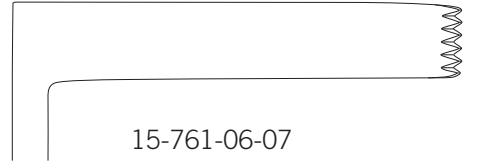

15-761-06-07

60 x 10 mm

Valve rechts voll
Blade rightfull
Valva a la derecha plena
Valve sur le bras à droite
Valva sul braccio destro

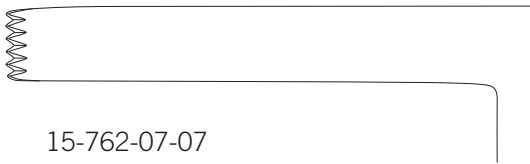

15-762-07-07

70 x 10 mm

Valve links voll
Blade left full
Valva a la izquierda plena
Valve sur le bras à gauche
Valva sul braccio sinistro

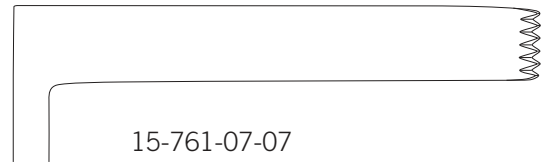

15-761-07-07

70 x 10 mm

Valve rechts voll
Blade rightfull
Valva a la derecha plena
Valve sur le bras à droite
Valva sul braccio destro



1/2

Williams
15-761-05-07 -
15-762-07-07
17 cm / 6 5/8"

Wundspreizer, selbsthaltend, Mittelvalven

Wound Spreaders, self-retaining, Central Blades

Separadores autoestáticos, valvas centrales

Ecarteurs autostatiques, valves centrales

Divaricatori autostatici, valve centrali

Wundhaken

Retractors

Separadores

Ecarteurs

Divaricatori

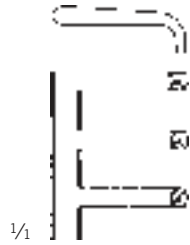
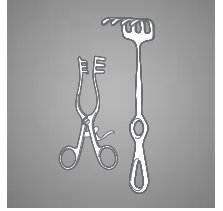

stumpf
blunt
romo
mousse
smusso



3:3



40 mm

1/2

Milligan
15-765-13-07
13,5 cm / 5 3/8"

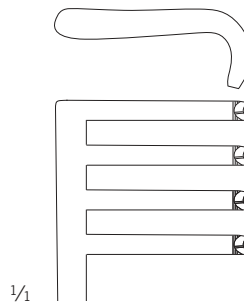

stumpf
blunt
romo
mousse
smusso



3:4



150 mm

1/1



1/2

Hartmann
15-767-00-07
26 cm / 10 2/8"

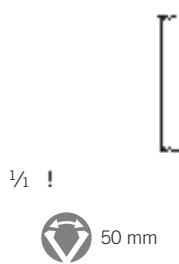

1/1 !



50 mm

1/2

Weitlaner-Baby
15-767-13-07
13,5 cm / 5 3/8"



1/2

15-767-01-07
30 x 15 mm
Mittelvalve
central blad
valva central
valve centrale
valva centrale

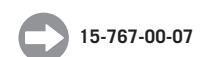

15-767-00-07

Wundspreizer, selbsthaltend, Mittelvalven

Wound Spreaders, self-retaining, Central Blades

Separadores autoestáticos, valvas centrales

Ecarteurs autostatiques, valves centrales

Divaricatori autostatici, valve centrali

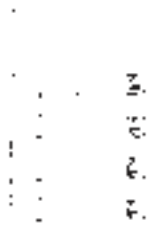

1/1

15-768-00-07



stumpf
blunt
romo
mousse
smusso

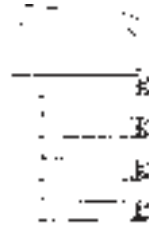

15-769-00-07



scharf
sharp
agudo
pointu
acuto



1/2

Henley
15-768-00-07 -
15-769-00-07
16,5 cm / 6 4/8"



1/2

15-768-19-07
19 x 17 mm



15-768-25-07
25 x 17 mm



15-768-32-07
32 x 17 mm



komplett mit 3 Mittelvalven
Art.-Nr. 15-768-19-07, 15-768-25-07 und 15-768-32-07

complete with 3 central blades
ref. 15-768-19-07, 15-768-25-07 and 15-768-32-07

completo con 3 valvas centrales
ref. 15-768-19-07, 15-768-25-07 y 15-768-32-07

complet avec 3 valves centrales
réf. 15-768-19-07, 15-768-25-07 et 15-768-32-07

completo con 3 valve centrali
rif. 15-768-19-07, 15-768-25-07 e 15-768-32-07

Wundspreizer, selbsthaltend

Wound Spreaders, self-retaining

Separadores autoestáticos

Ecarteurs autostatiques

Divaricatori autostatici

Wundhaken

Retractors

Separadores

Ecarteurs

Divaricatori

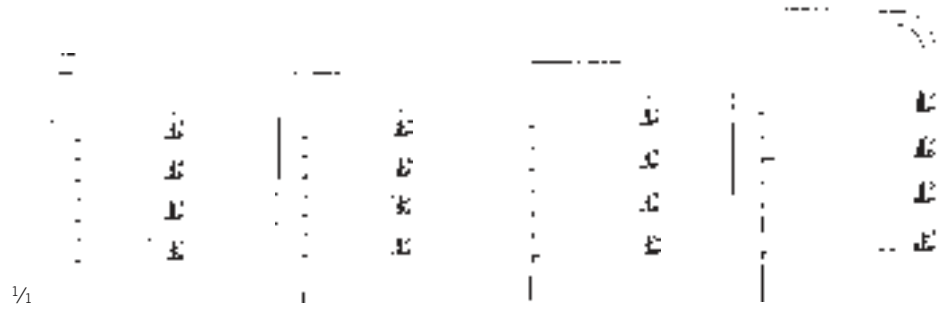

scharf sharp agudo pointu acuto		15-770-13-07	15-770-16-07	15-770-20-07	15-770-26-07
		14 cm / 5 ⁴ / ₈ "	16,5 cm / 6 ⁴ / ₈ "	21 cm / 8 ² / ₈ "	24,5 cm / 9 ⁵ / ₈ "
		81 mm	90 mm	135 mm	135 mm
		3:4	3:4	3:4	3:4

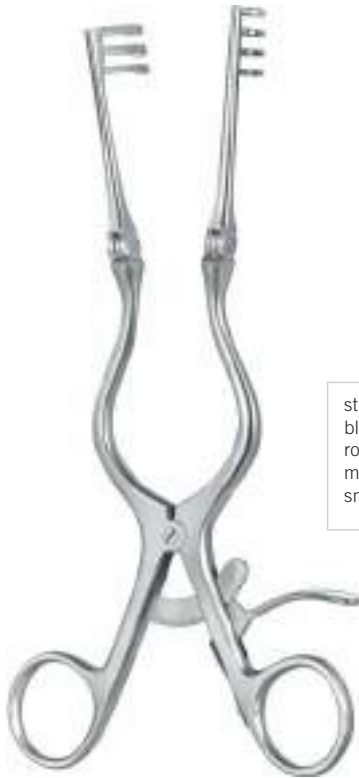

1/2

Adson
15-770-13-07 -
15-772-26-07

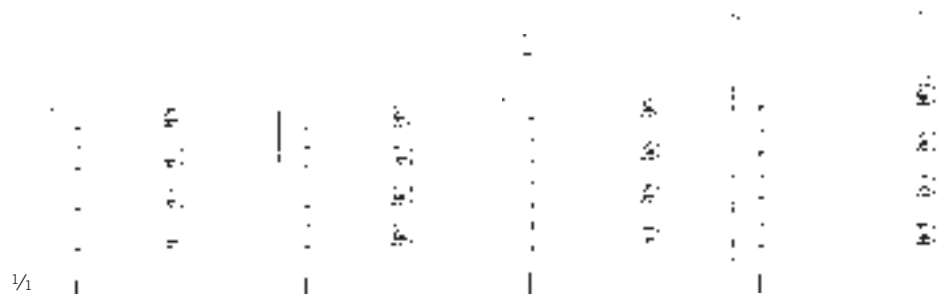

stumpf blunt romo mousse smusso		15-771-13-07	15-771-16-07	15-771-20-07	15-771-26-07
		14 cm / 5 ⁴ / ₈ "	16,5 cm / 6 ⁴ / ₈ "	21 cm / 8 ² / ₈ "	24,5 cm / 9 ⁵ / ₈ "
		81 mm	90 mm	135 mm	135 mm
		3:4	3:4	3:4	3:4

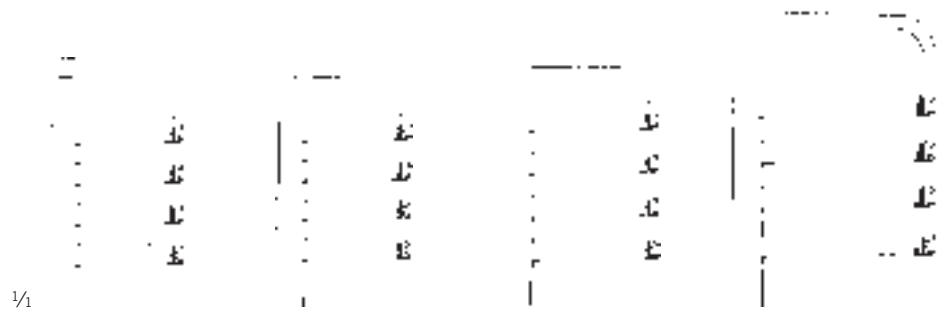

halbscharf semi-sharp semi-agudo semi-pointu semi acuto		15-772-13-07	15-772-16-07	15-772-20-07	15-772-26-07
		14 cm / 5 ⁴ / ₈ "	16,5 cm / 6 ⁴ / ₈ "	21 cm / 8 ² / ₈ "	24,5 cm / 9 ⁵ / ₈ "
		81 mm	90 mm	135 mm	135 mm
		3:4	3:4	3:4	3:4

15

Wundspreizer, selbsthaltend

Wound Spreaders, self-retaining

Separadores autoestáticos

Ecarteurs autostatiques

Divaricatori autostatici

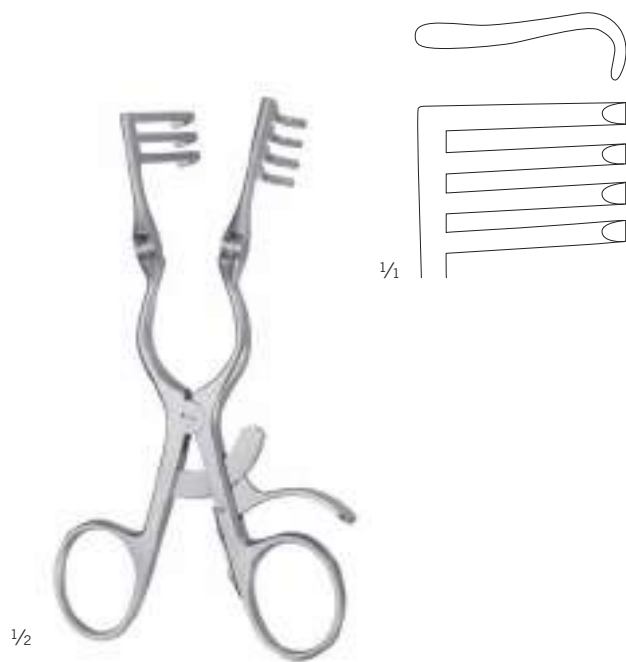

Adson
15-773-13-07

14 cm / 5 $\frac{4}{8}$ "

stumpf

blunt

romo

mousse

smusso



3:4



60 mm

Wundspreizer, selbsthaltend, Valven

Wound Spreaders, self-retaining, Blades

Separadores autoestáticos, valvas

Ecarteurs autostatiques, valves

Divaricatori autostatici, valve

Wundhaken

Retractors

Separadores

Ecarteurs

Divaricatori



1/2

Cloward

15-774-00-07

komplett mit je 2 Steckvalven

Art.-Nr. 15-774-40-07 - 15-774-60-07

with 2 each plug-in blades

ref. 15-774-40-07 - 15-774-60-07

con 2 valvas enchufables de c.u.

ref. 15-774-40-07 - 15-774-60-07

chacun avec 2 valves interchangeables

réf. 15-774-40-07 - 15-774-60-07

con 2 valve ad innesto

rif. 15-774-40-07 - 15-774-60-07

1/2



15-774-40-07

4 cm / 1 5/8"



15-774-00-07 & 15-774-25-07

gezahnt, Paar
toothed, pair
dentado, par
dentelé, paire
dentato, paio



15-774-45-07

4,5 cm / 1 9/16"



15-774-00-07 & 15-774-25-07

gezahnt, Paar
toothed, pair
dentado, par
dentelé, paire
dentato, paio



15-774-50-07

5 cm / 2"



15-774-00-07 & 15-774-25-07

gezahnt, Paar
toothed, pair
dentado, par
dentelé, paire
dentato, paio



15-774-55-07

5,5 cm / 2 1/8"



15-774-00-07 & 15-774-25-07

gezahnt, Paar
toothed, pair
dentado, par
dentelé, paire
dentato, paio



15-774-60-07

6 cm / 2 3/8"



15-774-00-07 & 15-774-25-07

gezahnt, Paar
toothed, pair
dentado, par
dentelé, paire
dentato, paio

15-774-25-07

25 cm / 9 7/8"

Sperrer allein

Spreader only

Separador suelto

Ecarteur seul

Divaricatore solo

15

Wundspreizer, selbsthaltend, Valven

Wound Spreaders, self-retaining, Blades

Separadores autoestáticos, valvas

Ecarteurs autostatiques, valves

Divaricatori autostatici, valve



15-775-40-07

4 cm / 1 5/8"



15-775-00-07 & 15-775-15-07

glatt, Paar
smooth, pair
lisa, par
lisse, paire
liscio, paio



15-775-45-07

4,5 cm / 1 5/8"



15-775-00-07 & 15-775-15-07

glatt, Paar
smooth, pair
lisa, par
lisse, paire
liscio, paio



15-775-50-07

5 cm / 2"



15-775-00-07 & 15-775-15-07

glatt, Paar
smooth, pair
lisa, par
lisse, paire
liscio, paio



15-775-55-07

5,5 cm / 2 1/8"



15-775-00-07 & 15-775-15-07

glatt, Paar
smooth, pair
lisa, par
lisse, paire
liscio, paio



1/2



15-775-60-07

6 cm / 2 3/8"



15-775-00-07 & 15-775-15-07

glatt, Paar
smooth, pair
lisa, par
lisse, paire
liscio, paio

Cloward

15-775-00-07

komplett mit je 2 Steckvalven
Art.-Nr. 15-775-40-07 - 15-775-60-07

with 2 each plug-in blades
ref. 15-775-40-07 - 15-775-60-07

con 2 valvas enchufables de c.u.
ref. 15-775-40-07 - 15-775-60-07

chacun avec 2 valves interchangeables
réf. 15-775-40-07 - 15-775-60-07

con 2 valve ad innesto
rif. 15-775-40-07 - 15-775-60-07

15-775-15-07

15 cm / 5 7/8"

Sperrer allein
Spreader only
Separador solo
Ecarteur seul
Divaricatore solo

Wundspreizer, selbsthaltend

Wound Spreaders, self-retaining

Separadores autoestáticos

Ecarteurs autostatiques

Divaricatori autostatici

Wundhaken

Retractors

Separadores

Ecarteurs

Divaricatori



1/1

15-776-31-07

32 cm / 12 5/8"

scharf
sharp
agudo
pointu
acuto



15-776-32-07

31,5 cm / 12 3/8"

halbscharf
sharp
agudo
pointu
acuto



1/2

Beckmann
15-776-31-07 -
15-776-32-07

15

Wundspreizer, selbsthaltend

Wound Spreaders, self-retaining

Separadores autoestáticos

Ecarteurs autostatiques

Divaricatori autostatici



1/2

Adson
15-777-32-07 -
15-777-33-07

33 cm / 13 "

1/4

15-777-32-07

scharf
sharp
agudo
pointu
acuto



4:5



15-777-33-07

halbscharf
semi-sharp
semi-agudo
semi-pointu
semi acuto



4:5



Wundspreizer, selbsthaltend

Wound Spreaders, self-retaining

Separadores autoestáticos

Ecarteurs autostatiques

Divaricatori autostatici

Wundhaken

Retractors

Separadores

Ecarteurs

Divaricatori



1/1

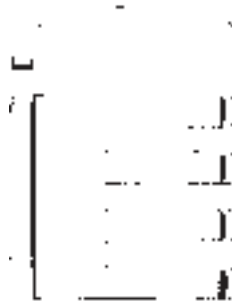

15-778-00-07

31 cm / 12 2/8"

stumpf
blunt
romo
mousse
smusso



15-778-01-07

31 cm / 12 2/8"

scharf
sharp
agudo
pointu
acuto



15-778-02-07

30,5 cm / 12 "

stumpf
blunt
romo
mousse
smusso



15-778-03-07

30,5 cm / 12 "

scharf
sharp
agudo
pointu
acuto



1/2

Beckman-Adson
15-778-00-07 -
15-778-03-07

15

Wundspreizer, selbsthaltend

Wound Spreaders, self-retaining

Separadores autoestáticos

Ecarteurs autostatiques

Divaricatori autostatici



1/1



1/2

Beckman-Eaton
15-778-32-07

32 cm / 12 5/8"

scharf
sharp
agudo
pointu
acuto

Wundspreizer, selbsthaltend

Wound Spreaders, self-retaining

Separadores autoestáticos

Ecarteurs autostatiques

Divaricatori autostatici

Wundhaken

Retractors

Separadores

Ecarteurs

Divaricatori

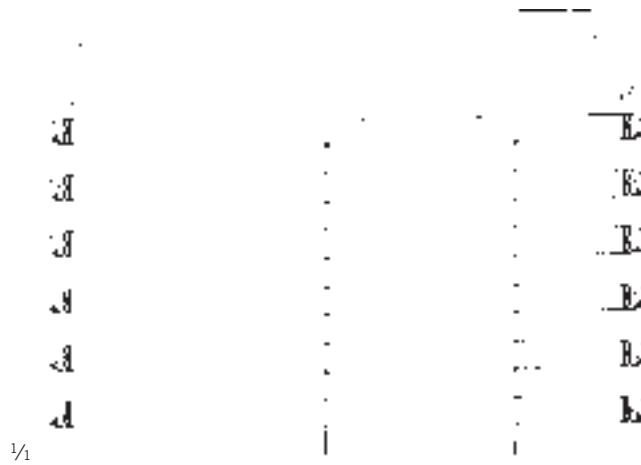
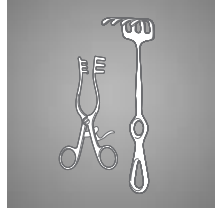

1/1

15-790-01-07

scharf, lange Zähne links
sharp, long teeth on left side
agudo, garfios largos a la izquierda
pointu, griffes longues à gauche
acuto, denti lunghi a sinistra



6:6



145 mm



15-790-02-07

scharf, lange Zähne rechts
sharp, long teeth on right side
agudo, garfios largos a la derecha
pointu, griffes longues à droite
acuto, denti lunghi a destra



6:6



145 mm



1/2

Martin
15-790-01-07 -
15-790-02-07
28,5 cm / 11 2/8"

15

Wundspreizer, selbsthaltend

Wound Spreaders, self-retaining

Separadores autoestáticos

Ecarteurs autostatiques

Divaricatori autostatici



1/2

Vickers Low-Profile 15-792-00-01

6 cm / 2 3/8"

komplett, mit Mittelvalve Art.-Nr.
complete, with central blade ref.
completo, con valva centrale réf.
complet, avec valve centrale réf.
completo, con valva centrale rif.

15-792-01-01

stumpf
blunt
romo
mousse
smusso



2:2



25 mm



1/2

Vickers Low-Profile 15-793-00-01

9 cm / 3 4/8"

komplett, mit Mittelvalve Art.-Nr.
complete, with central blade ref.
completo, con valva centrale réf.
complet, avec valve centrale réf.
completo, con valva centrale rif.

15-792-01-01

stumpf
blunt
romo
mousse
smusso



3:3



30 mm



1/2

Vickers Low-Profile 15-794-00-01

7,5 cm / 3 "

komplett, mit Mittelvalve Art.-Nr.
complete, with central blade ref.
completo, con valva centrale réf.
complet, avec valve centrale réf.
completo, con valva centrale rif.

15-792-01-01



25 mm

15-794-90-98

Feder
Spring
Pluma
Plume
Piuma



15-794-00-01

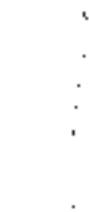

1/1

15-792-01-01

Mittelvalven
Central Blades
Valvas centrales
Valves centrales
Valve centrali

10 x 18 mm



**15-792-00-01,
15-793-00-01,
15-794-00-01,**

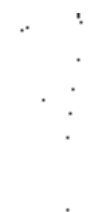

1/1

15-792-02-01

Mittelvalven
Central Blades
Valvas centrales
Valves centrales
Valve centrali

10 x 12 mm



**15-792-00-01,
15-793-00-01,
15-794-00-01,**



1/1

Vickers 15-798-01-01

5 cm / 3 "

stumpf, Ringmodell, für Daumen und Finger
blunt, ring model, for thumb and fingers
romo, forma de anillo, para pulgar y dedos
mousse, modèle anneau, pour pouce et doigts
smusso, modello anulare, per pollice e le dita

Wundspreizer, selbsthaltend

Wound Spreaders, self-retaining

Separadores autoestáticos

Ecarteurs autostatiques

Divaricatori autostatici

Wundhaken

Retractors

Separadores

Ecarteurs

Divaricatori



1/2

Joll
15-801-00-07

15,5 cm / 6 1/8"

Thyreoid- und Vulva-Spreizer
Thyroid and Vaginal retractor
Separador para tiroides y vagina
Ecarteur pour thyroïde et vulva
Divaricatore per tiroide e vagina



1/2

Gelpi
15-802-13-07

13 cm / 5 1/8"

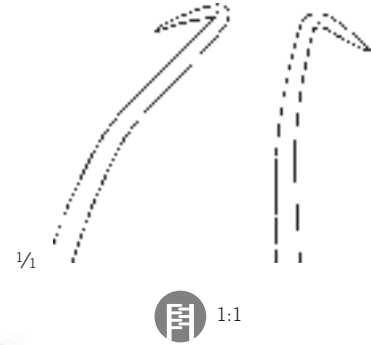

1/1



1:1

15



1/2

Gelpi
15-802-18-07

18 cm / 7 1/8"

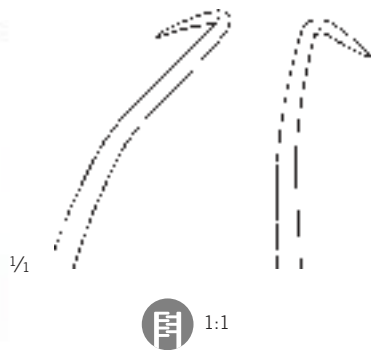

1/1



1:1



1/2

Gelpi
15-804-18-07

18,5 cm / 7 3/8"

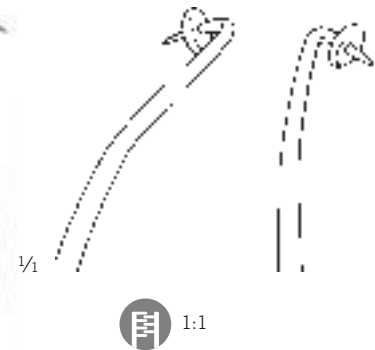

1/1



1:1

Bauchdeckenhalter

Abdominal Retractors
Separadores abdominales
Ecarteurs abdominaux
Divaricatori addominali

Gesamtlänge Bauchdeckenhalter ohne Valve
Total length of abdominal retractor without blade
Longitud total separador abdominal sin valva
Longueur totale écarteur abdominal sans valve
Lunghezza totale divaricatore addominale senza valva



1/2

Collin, Baby
15-820-00-07

18 cm / 7 1/8"

komplett, mit 2 Paar Seitenvalven Art.-Nr. 15-839-18-07 (18 x 40 mm) und 15-839-27-07 (27 x 40 mm)
complete, with 2 pairs of lateral blades ref. 15-839-18-07 (18 x 40 mm) and 15-839-27-07 (27 x 40 mm)
completo, con 2 pares de valvas laterales ref. 15-839-18-07 (18 x 40 mm) y 15-839-27-07 (27 x 40 mm)
complet, avec 2 paires de valves latérales réf. 15-839-18-07 (18 x 40 mm) et 15-839-27-07 (27 x 40 mm)
completo, con 2 paia di valve laterali ref. 15-839-18-07 (18 x 40 mm) e 15-839-27-07 (27 x 40 mm)



60 mm



1/2

Collin
15-822-22-07

20 cm / 7 7/8"

komplett, mit 1 Paar Seitenvalven Art.-Nr. 15-839-38-07 (38 x 60 mm)
complete, with 1 pair of lateral blades ref. 15-839-38-07 (38 x 60 mm)
completo, con 1 par de valvas laterales ref. 15-839-38-07 (38 x 60 mm)
complet, avec 1 paire de valves latérales réf. 15-839-38-07 (38 x 60 mm)
completo, con 1 paio di valve laterali rif. 15-839-38-07 (38 x 60 mm)



80 mm

Bauchdeckenhalter

Abdominal Retractors
Separadores abdominales
Ecarteurs abdominaux
Divaricatori addominali

Wundhaken

Retractors
Separadores
Ecarteurs
Divaricatori



Gesamtlänge Bauchdeckenhalter ohne Valve
Total length of abdominal retractor without blade
Longitud total separador abdominal sin valva
Longueur totale écarteur abdominal sans valve
Lunghezza totale divaricatore addominale senza valva



1/2

15-823-90-98

Mittelvalve
central blad
valva central
valve centrale
valva centrale



15-823-00-07

15-824-90-98

Mittelvalve
central blad
valva central
valve centrale
valva centrale



15-824-00-07

Collin

15-823-00-07

20 cm / 7 7/8"

komplett, mit 1 Paar Seitenvalven Art.-Nr. 15-839-38-07 (38 x 60 mm) und Mittelvalve Art.-Nr. 15-823-90-98-07 (38 x 55 mm)
complete, with 1 pair of lateral blades ref.15-839-38-07 (38 x 60 mm) and central blade ref. 15-823-90-98-07 (38 x 55 mm)
completo, con 1 par de valvas laterales ref. 15-839-38-07 (38 x 60 mm) y valva central ref. 15-823-90-98-07 (38 x 55 mm)
complet, avec 1 paire de valves latérales réf. 15-839-38-07 (38 x 60 mm) et valve centrale réf.15-823-90-98-07 (38 x 55 mm)
completo, con 1 paio di valva laterali rif. 15-839-38-07 (38 x 60 mm) e valva centrale rif. 15-823-90-98 (38 x 55 mm)



100 mm

Collin

15-824-00-07

20 cm / 7 7/8"

komplett, mit 1 Paar Seitenvalven Art.-Nr. 15-839-45-07 (45 x 80 mm) und Mittelvalve Art.-Nr. 15-824-90-98 (50 x 75 mm)
complete, with 1 pair of lateral blades ref. 15-839-45-07 (45 x 80 mm) and central blade ref. 15-824-90-98 (50 x 75 mm)
completo, con 1 par de valvas laterales ref.15-839-45 (45 x 80 mm) y valva central ref. 15-824-90-98 (50 x 75 mm)
complet, avec 1 paire de valves latérales réf. 15-839-45-07 (45 x 80 mm) et valve centrale réf. 15-824-90-98 (50 x 75 mm)
completo, con 1 paio di valva laterali rif. 15-839-45-07 (45 x 80 mm) e valva centrale rif. 15-824-90-98 (50 x 75 mm)



100 mm

Bauchdeckenhalter

Abdominal Retractors
Separadores abdominales
Ecarteurs abdominaux
Divaricatori addominali

Gesamtlänge Bauchdeckenhalter ohne Valve
Total length of abdominal retractor without blade
Longitud total separador abdominal sin valva
Longueur totale écarteur abdominal sans valve
Lunghezza totale divaricatore addominale senza valva



15-826-90-98

Mittelvalve
central blad
valva central
valve centrale
valva centrale



15-826-00-07

1/2

Collin

15-826-00-07

31 cm / 12²/₈"

komplett, mit 1 Paar Seitenvalven Art.-Nr. 15-839-60-07
(60 x 80 mm) und Mittelvalve Art.-Nr. 15-826-90-98 (60 x 75 mm)

complete, with 1 pair of lateral blades ref. 15-839-60-07
(60 x 80 mm) and central blade ref. 15-826-90-98 (60 x 75 mm)

completo, con 1 par de valvas laterales ref. 15-839-60-07
(60 x 80 mm) y valva central ref. 15-826-90-98 (60 x 75 mm)

complet, avec 1 paire de valves latérales réf. 15-839-60-07
(60 x 80 mm) et valve centrale réf. 15-826-90-98 (60 x 75 mm)

completo, con 1 paio di valve laterali rif. 15-839-60-07
(60 x 80 mm) e valva centrale réf. 15-826-90-98 (60 x 75mm)



140 mm

Bauchdeckenhalter

Abdominal Retractors
 Separadores abdominales
 Ecarteurs abdominaux
 Divaricatori addominali

Wundhaken

Retractors
 Separadores
 Ecarteurs
 Divaricatori

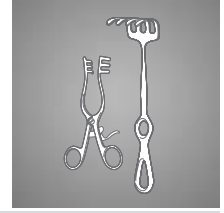

1/2

Ricard 15-830-00-07

komplett mit 1 Paar Seitenvalven Art.-Nr. 15-839-92-07 und Mittelvalve Art.-Nr. 15-830-04-07
 complete with 1 pair of lateral blades ref. 15-839-92-07 and central blade ref. 15-830-04-07
 completo con 1 par de valvas laterales ref. 15-839-92-07 y valva central ref. 15-830-04-07
 complet avec 1 paire de valves latérales ref. 15-839-92-07 et valve centrale ref. 15-830-04-07
 completo con 1 paio di valve laterali rif. 15-839-92-07 e valva centrale rif. 15-830-04-07



220 mm

15-830-02-07

Mittelvalve
 Central Blade
 Valva central
 Valva central
 Valva centrale
55 x 70 mm

15-830-04-07

Mittelvalve
 Central Blade
 Valva central
 Valva central
 Valva centrale
80 x 90 mm

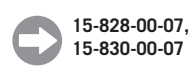

15-828-00-07,
15-830-00-07

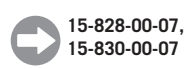

15-828-00-07,
15-830-00-07



15-839-90-07

Stück
 piece
 pieza
 pièce
 pezzo



15-839-92-07

Stück
 piece
 pieza
 pièce
 pezzo

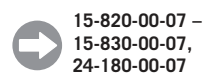

15-820-00-07 –
15-830-00-07,
24-180-00-07

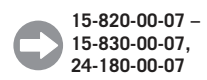

15-820-00-07 –
15-830-00-07,
24-180-00-07

Ricard 15-828-00-07

komplett mit 1 Paar Seitenvalven Art.-Nr. 15-839-90-07 und Mittelvalve Art.-Nr. 15-830-02-07
 complete with 1 pair of lateral blades ref. 15-839-90-07 and central blade ref. 15-830-02-07
 completo con 1 par de valvas laterales ref. 15-839-90-07 y valva central ref. 15-830-02-07
 complet avec 1 paire de valves latérales ref. 15-839-90-07 et valve centrale ref. 15-830-02-07
 completo con 1 paio di valve laterali rif. 15-839-90-07 e valva centrale rif. 15-830-02-07



250 mm

Ricard 15-828-01-07

Sperrer, allein
 Spreader, only
 Bastidor, suelto
 Ecarteur, seule
 Divaricatore, solo

Seitenvalven

Lateral Blades
Valvas laterales
Valves laterales
Valve laterali



1/2

15-839-18-07 -
15-839-60-07

für Bauchdeckenhalter
for abdominal retractors
para separadores abdominales
pour écarteurs abdominaux
per divaricatori addominali



15-820-00-07 -
15-826-00-07

1/4

15-839-18-07
18 x 40 mm

15-839-27-07
27 x 40 mm

15-839-38-07
38 x 60 mm

15-839-45-07
45 x 80 mm

15-839-60-07
60 x 80 mm

Seitenvalven

Lateral Blades
Valvas laterales
Valves laterales
Valve laterali

Wundhaken

Retractors
Separadores
Ecarteurs
Divaricatori

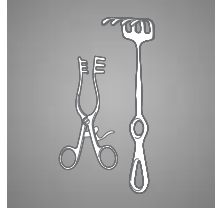

1/2

15-839-50-07 -
15-839-94-07

für Bauchdeckenhalter
for abdominal retractors
para separadores abdominales
pour écarteurs abdominaux
per divaricatori addominali



15-820-00-07 -
15-826-00-07

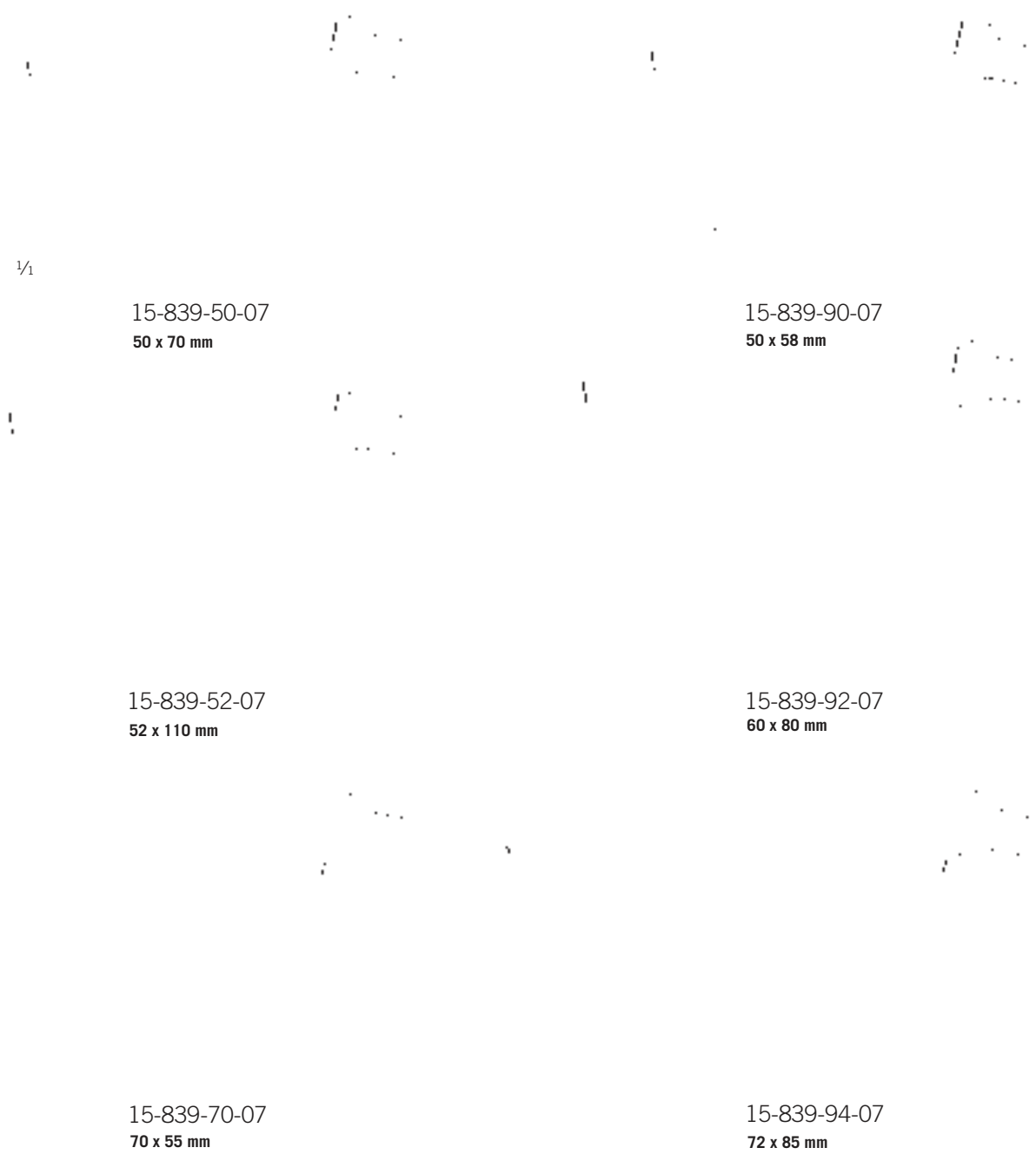

1/4

15-839-50-07
50 x 70 mm

15-839-90-07
50 x 58 mm

15-839-52-07
52 x 110 mm

15-839-92-07
60 x 80 mm

15-839-70-07
70 x 55 mm

15-839-94-07
72 x 85 mm

15

Bauchdeckenhalter

Abdominal Retractors
Separadores abdominales
Ecarteurs abdominaux
Divaricatori addominali



1/2

Gosset
15-844-00-07 -
15-844-91-98

16,5 cm / 6 4/8"

Seitenvalven 63 x 35 mm,
1 Mittelvalve 60 x 65 mm
lateral blades 63 x 35 mm,
1 central blade 60 x 65 mm
valvas laterales 63 x 35 mm,
1 valva central 60 x 65 mm
valves latérales 63 x 35 mm,
1 valve centrale 60 x 65 mm
valve laterali 63 x 35 mm,
1 valva centrale 60 x 65 mm



160 mm

15-844-91-98

Mittelvalve
central blad
valva central
valve centrale
valva centrale
60 x 65 mm



15-844-00-07



1/2

Gosset-Baby
15-840-00-07

12,5 cm / 4 7/8"

Seitenvalven
lateral blades
valvas laterales
valves latérales
valve laterali
40 x 30 mm



120 mm

Bauchdeckenhalter

Abdominal Retractors
Separadores abdominales
Ecarteurs abdominaux
Divaricatori addominali

Wundhaken

Retractors
Separadores
Ecarteurs
Divaricatori



15-850-92-99

12,5 cm / 4 7/8"

Mittelvalve
central blade
valva central
valve centrale
valva centrale
24 x 20 mm

➔ 15-850-00-07

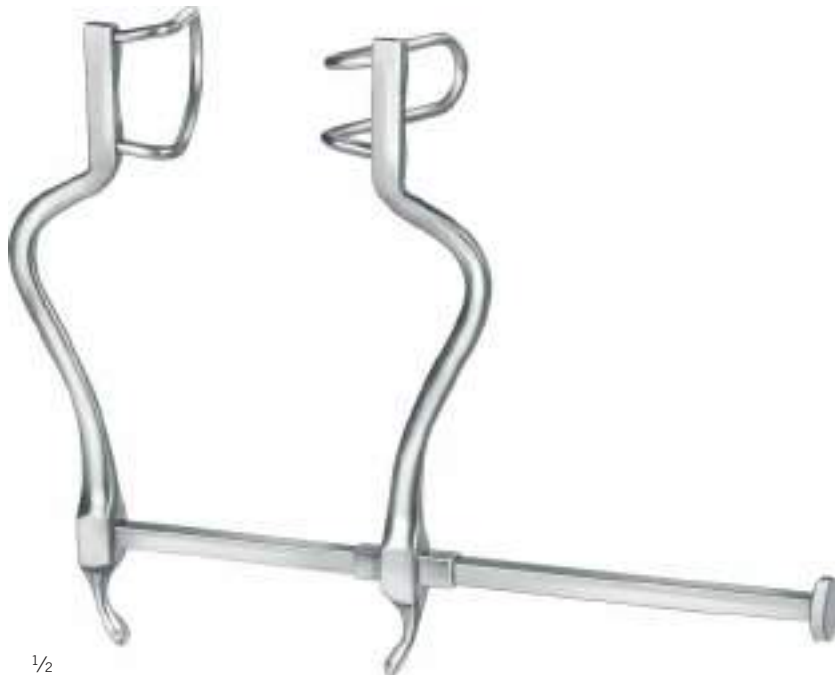

Gosset
15-846-00-07

18,5 cm / 7 2/8"

Seitenvalven
lateral blades
valvas laterales
valves latérales
valve laterali
63 x 35 mm



140 mm

Balfour-Baby
15-850-00-07

12,5 cm / 4 7/8"

komplett, mit 1 Paar Seitenvalven (30 x 20 mm)
und Mittelvalve Art.-Nr. 15-850-92-99 (24 x 20 mm)
complete, with 1 pair of lateral blades (30 x 20 mm)
and central blade ref. 15-850-92-99 (24 x 20 mm)
completo, con 1 par de valvas laterales (30 x 20 mm)
y valva central ref. 15-850-92-99 (24 x 20 mm)
complet, avec 1 paire de valves latérales (30 x 20 mm)
et valve centrale réf. 15-850-92-99 (24 x 20 mm)
completo, con 1 paio di valve laterali (30 x 20 mm)
e valva centrale rif. 15-850-92-99 (24 x 20 mm)



80 mm

Bauchdeckenhalter

Abdominal Retractors
Separadores abdominales
Ecarteurs abdominaux
Divaricatori addominali



1/2

Balfour 15-852-00-07

20 cm / 7 7/8"

komplett, mit 1 Paar Seitenvalven (70 x 35 mm)
und Mittelvalve Art.-Nr. 15-859-01-07 (45 x 80 mm)
complete, with 1 pair of lateral blades (70 x 35 mm)
and central blade ref. 15-859-01-07 (45 x 80 mm)
completo, con 1 par de valvas laterales (70 x 35 mm)
y valva central ref. 15-859-01-07 (45 x 80 mm)
complet, avec 1 paire de valves latérales (70 x 35 mm)
et valve centrale réf. 15-859-01-07 (45 x 80 mm)
completo, con 1 paio di valve laterali (70 x 35 mm)
e valva centrale rif. 15-859-01-07 (45 x 80 mm)



1/2

Balfour 15-854-00-07

20 cm / 7 7/8"

komplett, mit 1 Paar Seitenvalven (70 x 35 mm)
und Mittelvalve Art.-Nr. 15-859-01-07 (45 x 80 mm)
complete, with 1 pair of lateral blades (70 x 35 mm)
and central blade ref. 15-859-01-07 (45 x 80 mm)
completo, con 1 par de valvas laterales (70 x 35 mm)
y valva central ref. 15-859-01-07 (45 x 80 mm)
complet, avec 1 paire de valves latérales (70 x 35 mm)
et valve centrale réf. 15-859-01-07 (45 x 80 mm)
completo, con 1 paio di valve laterali (70 x 35 mm)
e valva centrale rif. 15-859-01-07 (45 x 80 mm)



Bauchdeckenhalter, Mittelvalven

Abdominal Retractors
Separadores abdominales
Ecarteurs abdominaux
Divaricatori addominali

Wundhaken

Retractors
Separadores
Ecarteurs
Divaricatori



1/2

Balfour 15-856-00-07

20 cm / 7 7/8"

komplett, mit 1 Paar Seitenvalven (100 x 35 mm)
und Mittelvalve Art.-Nr. 15-856-91-98 (100 x 60 mm)

complete, with 1 pair of lateral blades (100 x 35 mm)
and central blade ref. 15-856-91-98 (100 x 60 mm)

completo, con 1 par de valvas laterales (100 x 35 mm)
y valva central ref. 15-856-91-98 (100 x 60 mm)

complet, avec 1 paire de valves latérales (100 x 35 mm)
et valve centrale réf. 15-856-91-98 (100 x 60 mm)

completo, con 1 paio di valve laterali (100 x 35 mm)
e valva centrale rif. 15-856-91-98 (100 x 60 mm)



180 mm

15-856-90-98

Mittelvalve
central blade
valva central
vlave centrale
vlava centrale
100 x 70 mm



15-856-00-07

15-856-91-98

Mittelvalve
central blade
valva central
vlave centrale
vlava centrale
100 x 60 mm



15-856-00-07

Bauchdeckenhalter, Mittelvalven

Abdominal Retractors
Separadores abdominales
Ecarteurs abdominaux
Divaricatori addominali



1/2

Balfour-Standard 15-858-00-07

20 cm / 7 7/8"

komplett, mit 1 Paar Seitenvlaven (100 x 35 mm)
und Mittelvalve Art.-Nr. 15-859-02-07 (68 x 85 mm)

complete, with 1 pair of lateral blades (100 x 35 mm)
and central blade ref. 15-859-02-07 (68 x 85 mm)

completo, con 1 par de valvas laterales (100 x 35 mm)
y valva central ref. 15-859-02-07 (68 x 85 mm)

complet, avec 1 paire de valves latérales (100 x 35 mm)
et valve centrale réf. 15-859-02-07 (68 x 85 mm)

completo, con 1 paio di valve laterali (100 x 35 mm)
e valva centrale rif. 15-859-02-07 (68 x 85 mm)



230 mm



1/2

Balfour 15-859-01-07 - 15-859-06-07

15-859-01-07
45 x 80 mm

15-859-02-07
68 x 85 mm

15-859-06-07
40 x 68 mm

Bauchdeckenhalter

Abdominal Retractors
Separadores abdominales
Ecarteurs abdominaux
Divaricatori addominali

Wundhaken

Retractors
Separadores
Ecarteurs
Divaricatori

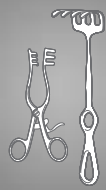

1/2

Balfour, Mod. USA 15-860-00-07

20 cm / 7 7/8"

komplett, mit je 1 Paar Seitenvalven Art.-Nr. 15-860-06-07 (60 x 30 mm), 15-860-08-07 (80 x 30 mm) und Mittelvalve Art.-Nr. 15-859-02-07 (68 x 85 mm)

complete, with 1 pair of lateral blades ref. 15-860-06-07 (60 x 30 mm), 15-860-08-07 (80 x 30 mm) and central blade ref. 15-859-02-07 (68 x 85 mm)

completo, con 1 par de valvas laterales ref. 15-860-06-07 (60 x 30 mm), 15-860-08-07 (80 x 30 mm) y valva central ref. 15-859-02-07 (68 x 85 mm)

complet, avec 1 paire de valves latérales réf. 15-860-06-07 (60 x 30 mm), 15-860-08-07 (80 x 30 mm) et valve centrale réf. 15-859-02-07 (68 x 85 mm)

completo, con 1 paio di valve laterali rif. 15-860-06-07 (60 x 30 mm), 15-860-08-07 (80 x 30 mm) e valva centrale rif. 15-859-02-07 (68 x 85 mm)



190 mm



15-860-06-07

Drahtvalven (Paar)
Fenestrated Blades (pair)
Valvas de alambre (par)
Valves en fil (paire)
Valve di filo (paio)

60 x 30 mm



15-860-00-07



15-860-08-07

Drahtvalven (Paar)
Fenestrated Blades (pair)
Valvas de alambre (par)
Valves en fil (paire)
Valve di filo (paio)

80 x 30 mm



15-860-00-07

Bauchdeckenhalter, Mittelvalven

Abdominal Retractors, Central Blades

Separadores abdominales, valvas centrales

Ecarteurs abdominaux, valves centrales

Divaricatori addominali, valve centrali



1/2

O'Sullivan-O'Connor 15-868-00-01

20 cm / 7 7/8"

komplett, mit 2 festen Seitenvlaven (60 x 35 mm)
und 2 Mittelvalven Art.-Nr. 15-868-90-98 (80 x 45 mm) und 15-868-91-98 (110 x 70 mm)

complete, with 2 fixed lateral blades (60 x 35 mm)
and 2 central blades ref. 15-868-90-98 (80 x 45 mm) and 15-868-91-98 (110 x 70 mm)

completo, con 2 vlavas laterales fijas (60 x 35 mm)
y 2 valvas centrales ref. 15-868-90-98 (80 x 45 mm) y 15-868-91-98 (110 x 70 mm)

complet, avec 2 valves latérales fixes (60 x 35 mm)
et 2 valves centrales réf. 15-868-90-98 (80 x 45 mm) et 15-868-91-98 (110 x 70 mm)

completo, con 2 valve laterali fisse (60 x 35 mm)
e 2 valve centrali rif. 15-868-90-98 (80 x 45 mm) e 15-868-91-98 (110 x 70 mm)



190 mm

15-868-90-98

Mittelvalve
central blad
valva central
valve centrale
valva centrale
80 x 45 mm



15-868-00-01

15-868-91-98

Mittelvalve
central blad
valva central
valve centrale
valva centrale
110 x 70 mm



15-868-00-01

Bauchdeckenhalter

Abdominal Retractors
Separadores abdominales
Ecarteurs abdominaux
Divaricatori addominali

Wundhaken

Retractors
Separadores
Ecarteurs
Divaricatori

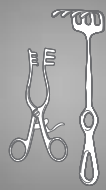

1/3

Kirschner 15-882-00-07

Rahmen Art.-Nr. 15-882-30-07, 3 Haken Art.-Nr. 15-889-50-07, und je 1 Haken Art.-Nr. 15-889-80-07, 15-889-98-07 und 15-889-99-07

Frame ref. 15-882-30-07, 3 retractors ref. 15-889-50-07 and 1 retractor each ref. 15-889-80-07, 15-889-98-07 and 15-889-99-07

Bastidor ref. 15-882-30-07, 3 retractor ref. 15-889-50-07 y 1 retractor c.u. ref. 15-889-80-07, 15-889-98-07 y 15-889-99-07

Cadre réf. 15-882-30-07, 3 rétracteurs réf. 15-889-50-07 et avec 1 rétracteurs réf. 15-889-80-07, 15-889-98-07 et 15-889-99-07

Telaio cod. art. 15-882-30-07, 3 retrattori cod. art. 15-889-50-07 e 1 retrattore ciascuno, cod. art. 15-889-80-07, 15-889-98-07 e 15-889-99-07

Kirschner 15-882-30-07

Rahmen, allein
Frame, only
Cuadro, solo
Cadre, seul
Telaio, solo

Innenmaß
Internal dimensions
Dimensiones interiores
Dimension intérieure
Misura interna

300 x 240 mm

Bauchdeckenhalter

Abdominal Retractors
Separadores abdominales
Ecarteurs abdominaux
Divaricatori addominali



1/3

Kirschner 15-884-00-07 - 15-884-24-07

Rahmen Art.-Nr. 15-884-24-07
und je 2 Haken Art.-Nr. 15-889-40-07 und 15-889-50-07

frame ref. 15-884-24-07,
2 hooks ref. 15-889-40-07 and 2 hooks ref. 15-889-50-07

bastidor ref. 15-884-24-07,
2 ganchos ref. 15-889-40-07 y 2 ganchos ref. 15-889-50-07

cadre réf. 15-884-24-07,
2 valves réf. 15-889-40-07 et 2 valves réf. 15-889-50-07

telaio rif. 15-884-24-07,
2 valve rif. 15-889-40-07 e 2 valve rif. 15-889-50-07

15-884-24-07

Rahmen, allein
Frame, only
Cuadro, solo
Cadre, seul
Telaio, solo

Innenmaß
Internal dimensions
Dimensiones interiores
Dimension intérieure
Misura interna

240 x 240 mm

Valven

Blades
Valvas
Valves
Valve

Wundhaken

Retractors
Separadores
Ecarteurs
Divaricatori

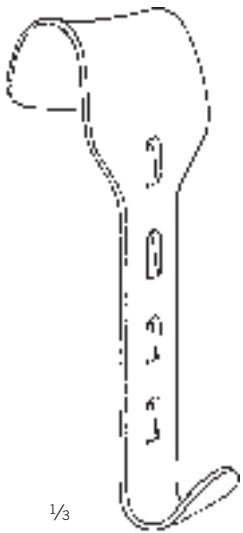
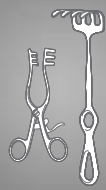

1/3

15-889-40-07
40 x 55 mm
Standard

➔ 15-882-30-07,
15-884-24-07

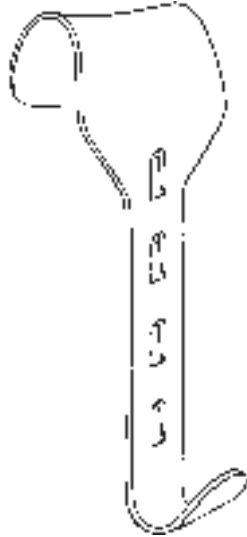

15-889-50-07
50 x 65 mm
Standard

➔ 15-882-30-07,
15-884-24-07

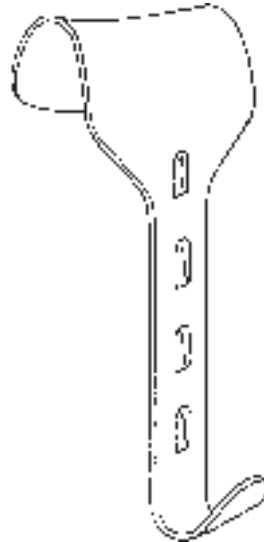

15-889-60-07
60 x 85 mm
Standard

➔ 15-882-30-07,
15-884-24-07

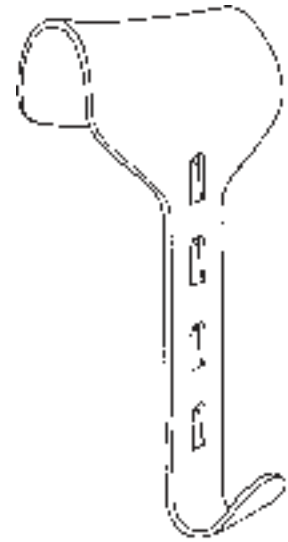

15-889-78-07
78 x 65 mm

➔ 15-882-30-07,
15-884-24-07

15

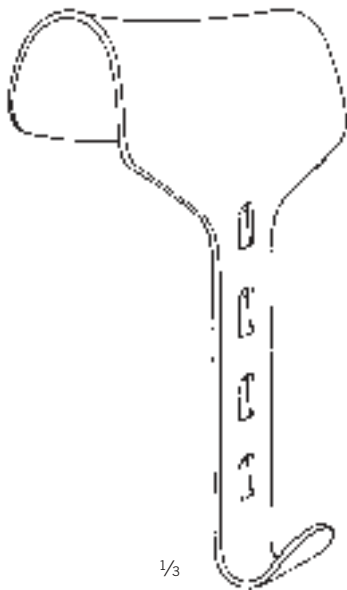

1/3

15-889-80-07
85 x 90 mm

➔ 15-882-30-07,
15-884-24-07

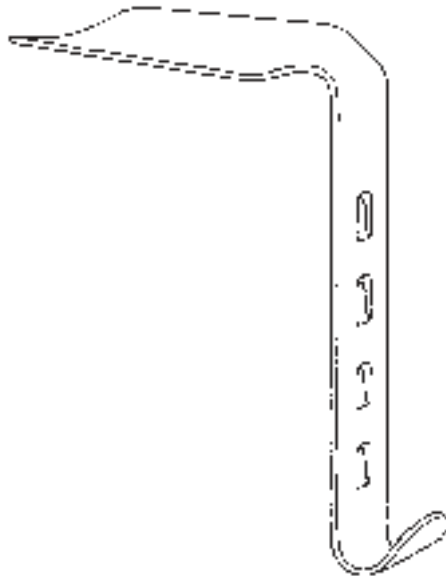

15-889-98-07
98 x 50 mm

➔ 15-882-30-07,
15-884-24-07

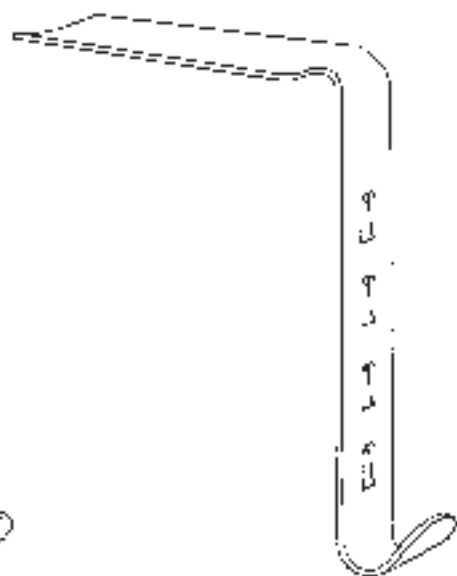

15-889-99-07
105 x 35 mm

➔ 15-882-30-07,
15-884-24-07

Laminektomiesperrer

Laminectomy Retractors

Separadores para laminectomía

Ecarteurs pour laminectomie

Divaricatori per laminectomia



1/2

Scoville
15-906-00-07

22 cm / 8 5/8"



190 mm



1/2

Scoville-Haverfield
15-906-50-07

22 cm / 8 5/8"

Rahmen allein, mit Gelenk
frame only, with joint
bastidor suelto, con articulación
cadre seul, avec articulation
telaio solo, con articolazione



190 mm

Valven

Blades
Valvas
Valves
Valve

Wundhaken

Retractors
Separadores
Ecarteurs
Divaricatori



1/2

15-906-01-07

5 cm / 2"

Hakenvalve, Stück
Hook, piece
Gancho, pieza
Valve à griffes, pièce
Uncino, pezzo

50 mm tief, stumpf
50 mm deep, blunt
50 mm de profundidad, romo
profondeur 50 mm, mousse
profondità 50 mm, smusso

➔ **15-906-00-07,**
15-906-50-07



15-906-02-07

7 cm / 2 6/8"

Hakenvalve, Stück
Hook, piece
Gancho, pieza
Valve à griffes, pièce
Uncino, pezzo

70 mm tief, stumpf
70 mm deep, blunt
70 mm de profundidad, romo
profondeur 70 mm, mousse
profondità 70 mm, smusso

➔ **15-906-00-07,**
15-906-50-07



15-906-06-07

5 cm / 2"

Hakenvalve, Stück
Hook, piece
Gancho, pieza
Valve à griffes, pièce
Uncino, pezzo

50 mm tief, spitz
50 mm deep, sharp
50 mm de profundidad, agudo
profondeur 50 mm, pointu
profondità 50 mm, acuto

➔ **15-906-00-07,**
15-906-50-07



15-906-07-07

7 cm / 2 6/8"

Hakenvalve, Stück
Hook, piece
Gancho, pieza
Valve à griffes, pièce
Uncino, pezzo

70 mm tief, spitz
70 mm deep, sharp
70 mm de profundidad, agudo
profondeur 70 mm, pointu
profondità 70 mm, acuto

➔ **15-906-00-07,**
15-906-50-07

15



1/2

15-906-11-07 -
15-906-13-07

Blattvalven, Stück
Blades, piece
Valvas, pieza
Valves, pièce
Valve, pezzo

gezahnt
toothed
dentado
dentelé
dentato

15-906-11-07 60 x 25 mm
15-906-12-07 61 x 50 mm
15-906-13-07 86 x 25 mm

➔ **15-906-00-07,**
15-906-50-07



15-906-41-07 -
15-906-44-07

Hakenvalve, Stück
Hook, piece
Valva, pieza
Valve, pièce
Valvola, pezzo

spitz
sharp
agudo
pointu
acuto

15-906-41-07 48 x 50 mm
15-906-42-07 64 x 50 mm
15-906-43-07 64 x 64 mm
15-906-44-07 80 x 57 mm

➔ **15-906-00-07,**
15-906-50-07



15-906-46-07 -
15-906-47-07

Hakenvalve, Stück
Hook, piece
Valva, pieza
Valve, pièce
Valvola, pezzo

spitz
sharp
agudo
pointu
acuto

15-906-46-07 44 x 38 mm
15-906-47-07 67 x 44 mm

➔ **15-906-00-07,**
15-906-50-07

Martin Arm-System

Martin Arm System
Sistema Brazo Martin
Système Bras Martin
Sistema braccio Martin



Martin

15-910-01-07

Martin Arm-System
Martin Arm System
Sistema Brazo Martin
Système Bras Martin
Sistema braccio Martin

15-910-10-04

Optikhalterung
Optics mounting
Recipiente de óptica
Support d'optique
Fissaggio di ottica

15-910-50-07

Universal-Befestigungskloben für Martin-Arm-System
Universal Fixation Clamp for Martin Arm system
Mordaza universal para sistema brazo Martin
Etau de maintien universel pour système bras Martin
Morsetto di fissaggio universale per sistema braccio Martin

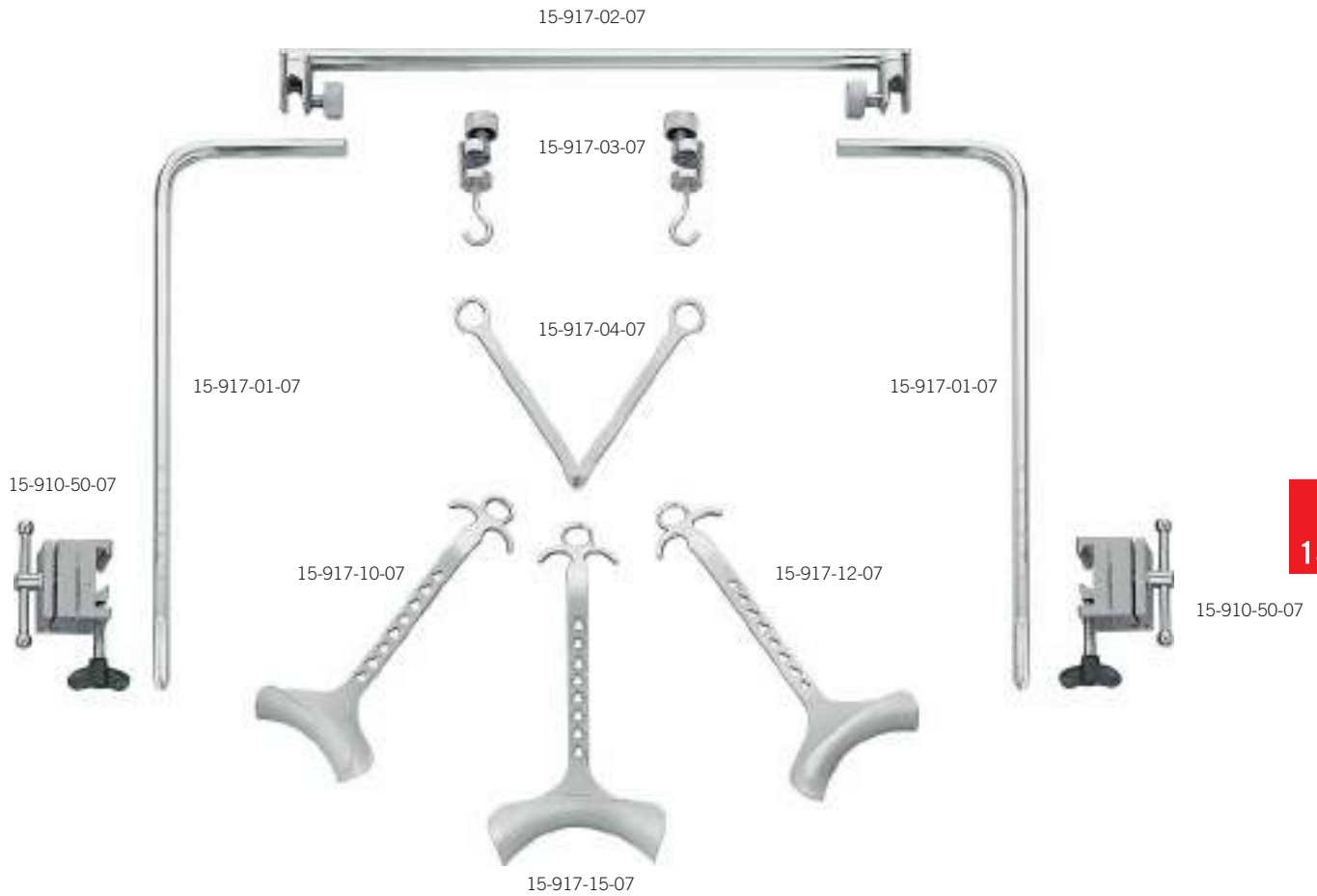

15

Martin-Rochard

15-917-00-07

Hakensystem
Retractor System
Sistema de Retractores
Système d'écarteurs
Sistema di divaricatori

komplett bestehend aus:		complete consisting of:		completo compuesto de:	
15-910-50-07	2 Universal-Befestigungskloben	15-910-50-07	2 Universal Fixation Clamp	15-910-50-07	2 Mordaza universal
15-917-01-07	2 Haltearm, seitlich	15-917-01-07	2 Fixation Arm, lateral	15-917-01-07	2 Brazo de fijación, lateral
15-917-02-07	1 Querstab, Sechskant	15-917-02-07	1 Cross Bar, hexagon	15-917-02-07	1 Barra transversal, hexagonal
15-917-03-07	2 Kloben	15-917-03-07	2 Sliding Clamp	15-917-03-07	2 Garrucha
15-917-04-07	1 Halterung für Haken	15-917-04-07	1 Fixing device for hooks	15-917-04-07	1 Soporte para ganchos
15-917-10-07	1 Wundhaken, 50 x 105 mm	15-917-10-07	1 Retractor, 50 x 105 mm	15-917-10-07	1 Separador, 50 x 105 mm
15-917-12-07	1 Wundhaken, 50 x 120 mm	15-917-12-07	1 Retractor, 50 x 120 mm	15-917-12-07	1 Separador, 50 x 120 mm
15-917-15-07	1 Wundhaken, 50 x 160 mm	15-917-15-07	1 Retractor, 50 x 160 mm	15-917-15-07	1 Separador, 50 x 160 mm

complet composé de:		completo composto di:	
15-910-50-07	2 Etau de maintien universel	15-910-50-07	2 Morsetto di fissaggio universale
15-917-01-07	2 Bras de fixation, latérale	15-917-01-07	2 Braccio di fissaggio, laterale
15-917-02-07	1 Barre transversale, hexagonale	15-917-02-07	1 Barra trasversale, hexagonale
15-917-03-07	2 Etou	15-917-03-07	2 Carrucola mobile
15-917-04-07	1 Maintien pour crochets	15-917-04-07	1 Supporto per divaricatori
15-917-10-07	1 Ecarteur, 50 x 105 mm	15-917-10-07	1 Divaricatore, 50 x 105 mm
15-917-12-07	1 Ecarteur, 50 x 120 mm	15-917-12-07	1 Divaricatore, 50 x 120 mm
15-917-15-07	1 Ecarteur, 50 x 160 mm	15-917-15-07	1 Divaricatore, 50 x 160 mm

Bauchspatel

Abdominal Spatulas
Espátulas abdominales
Spatules abdominales
Spatole addominali



15-963-01-01

33 cm / 13 "

30 mm

15-963-02-01

33 cm / 13 "

40 mm

15-963-03-01

33 cm / 13 "

50 mm

1/2

15-963-01-01 -
15-963-03-01

biegsam
malleable
maleable
malléable
malleabili



15-971-00-01

20 cm / 7 7/8"

16 mm - 25 mm

15-971-01-01

28 cm / 11 "

25 mm - 30 mm

15-971-02-01

30 cm / 11 6/8"

37 mm - 45 mm

1/2

Haberer
15-971-00-01 -
15-971-02-01

konische Form
tapered
forma cónica
forme conique
forma conica



15-975-06-01

20 cm / 7 7/8"

6,5 mm

15-975-09-01

20 cm / 7 7/8"

9,5 mm

15-975-13-01

20 cm / 7 7/8"

13 mm

15-975-16-01

20 cm / 7 7/8"

16 mm

15-975-19-01

20 cm / 7 7/8"

19 mm

15-975-25-01

20 cm / 7 7/8"

25 mm

1/2

Martin
15-975-06-01 -
15-975-25-01

biegsam, sehr weich
malleable, very soft
maleable, muy blando
malléable, très souple
malleabili, molto dolci

16

Sonden, Watteträger, Spatel
Probes, Applicators, Spatulas
Sondas, Porta-algodones, Espátulas
Sondes, porte-cotons, spatules
Sonde, portacotoni, spatole

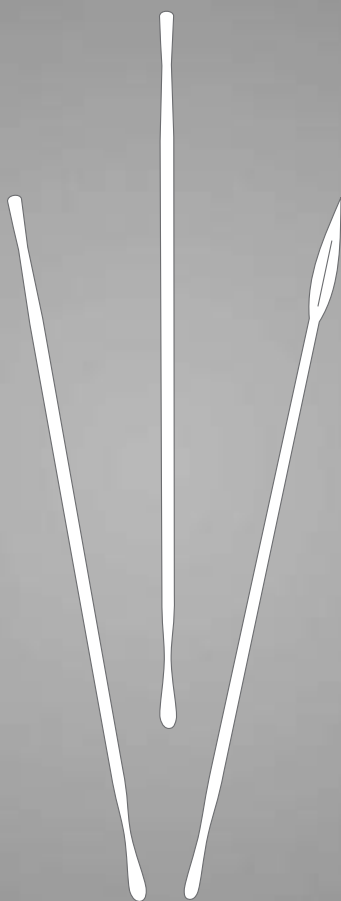

Knopfsonden

Probes

Sondas abotonadas

Sondes boutonées

Sonde a bottone

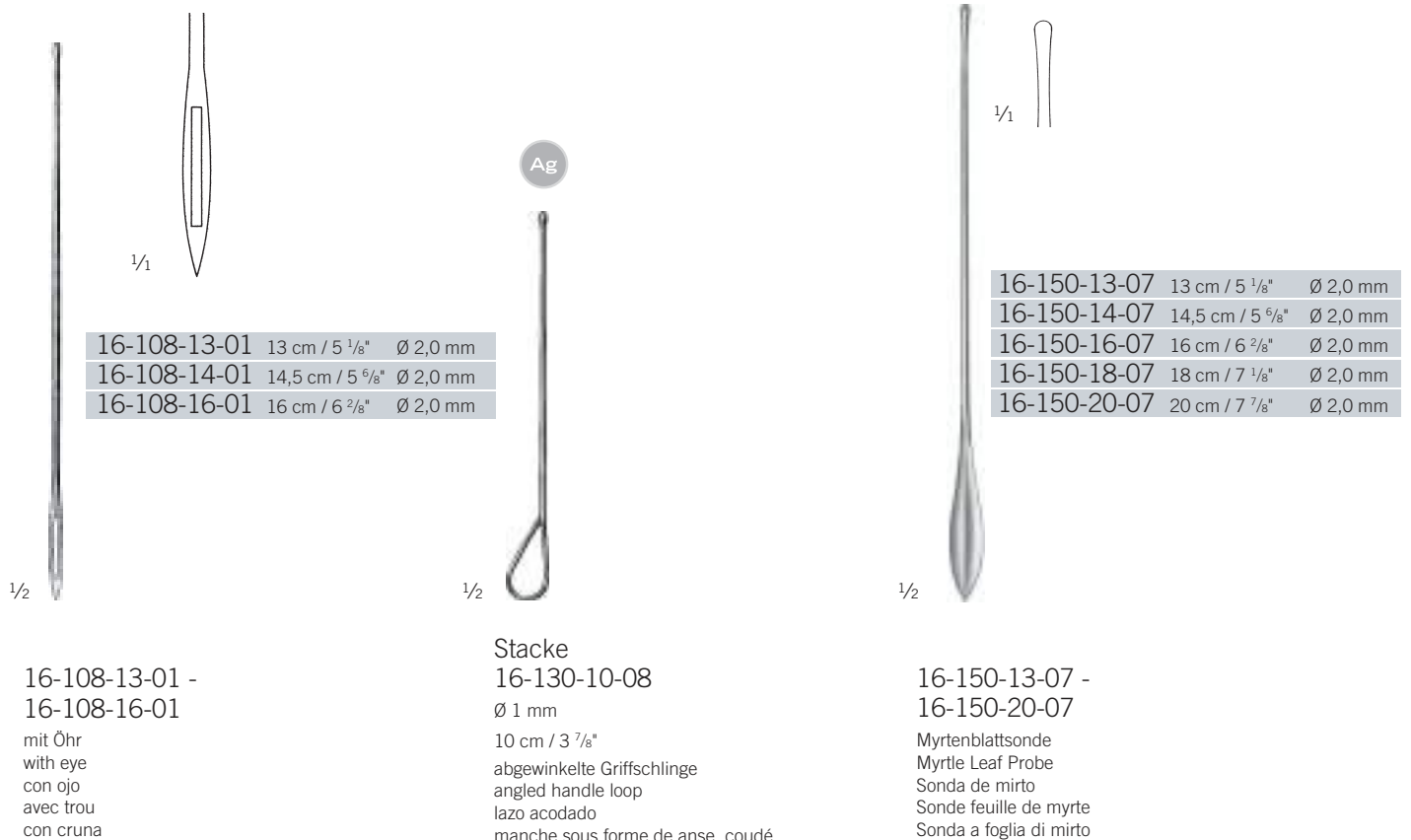
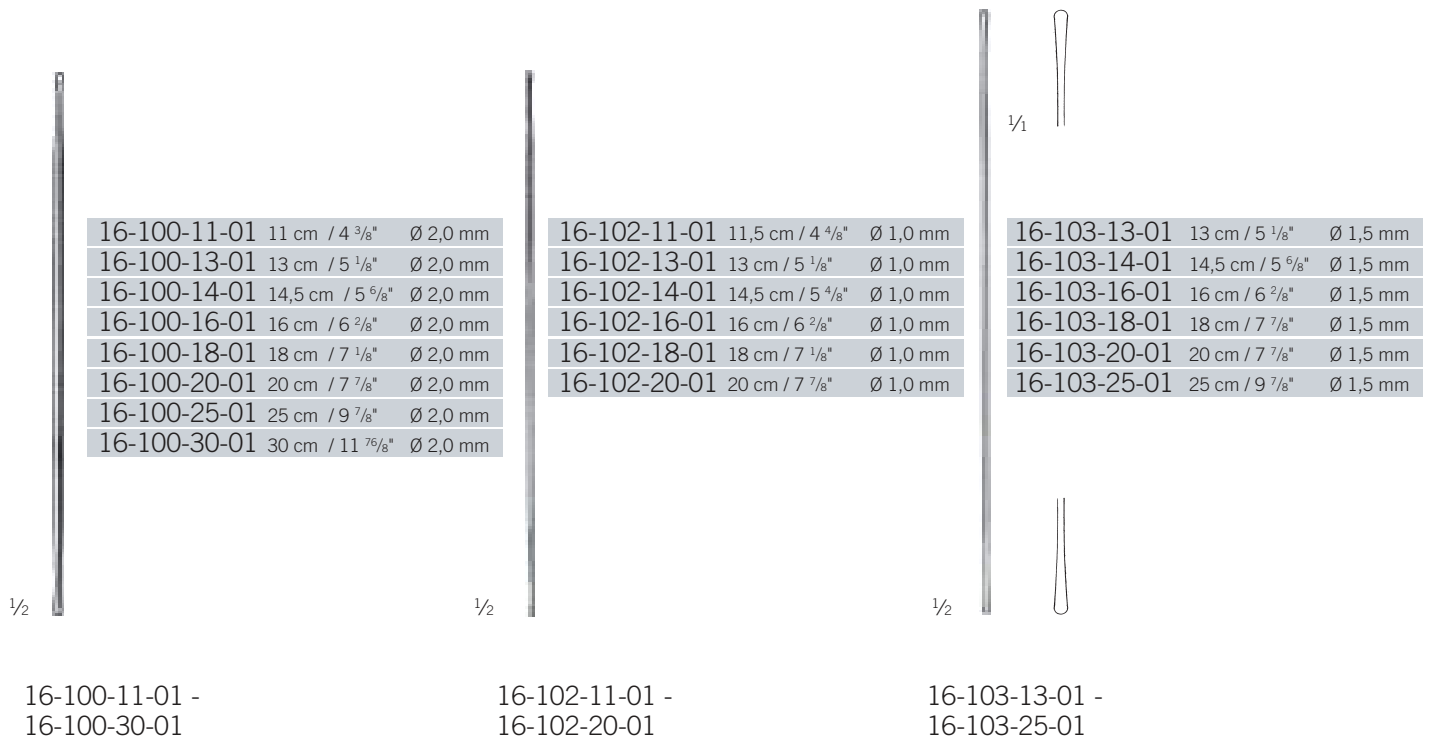

Hohlsonden, Fistelsonden

Grooved Directors, Fistula Probes

Sondas acanaladas, Sondas para fístula

Sondes cannelées, Sondes pour fistule

Sonde cannellate, Sonde per fistole

Sonden, Watteträger, Spatel

Probes, Applicators, Spatulas

Sondas, Porta-algodones, Espátulas

Sondes, porte-cotons, spatules

Sonde, portacotoni, spatole

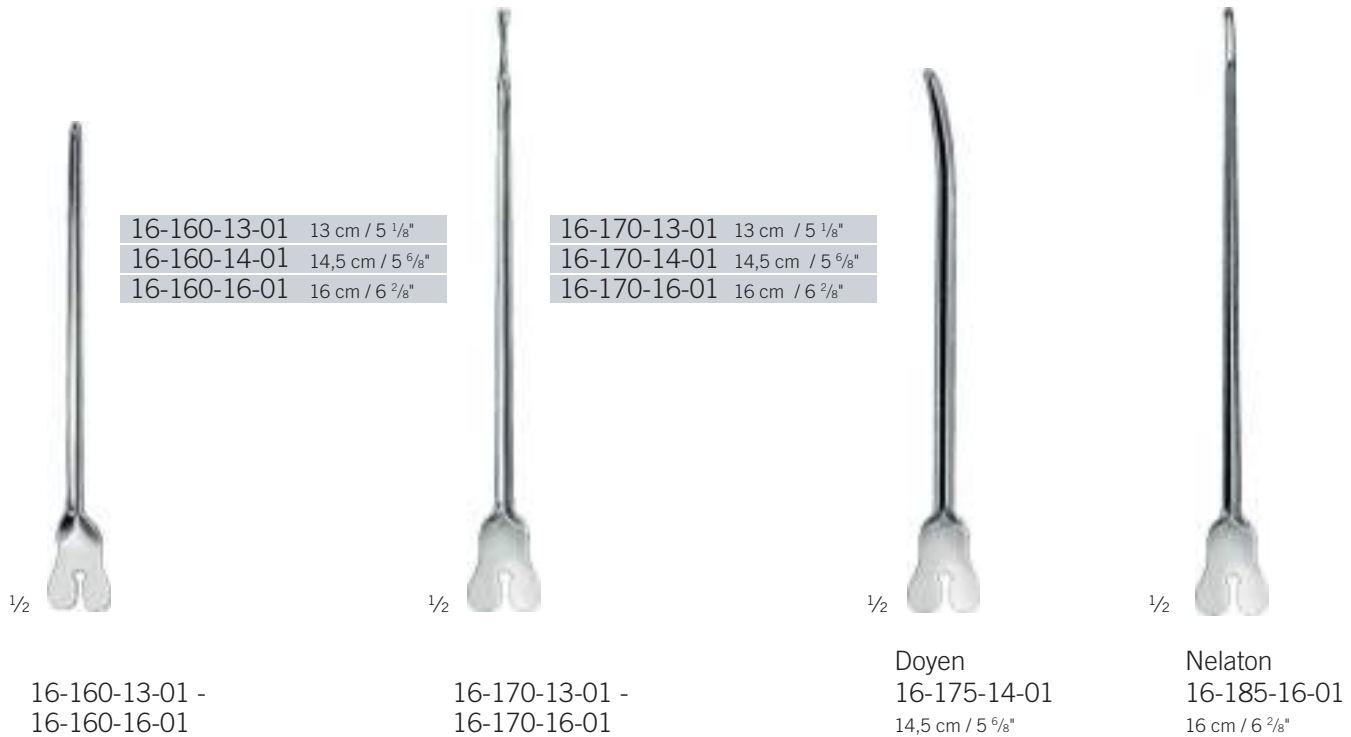
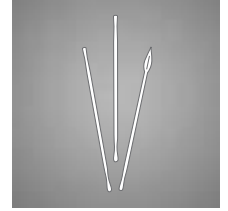

16



Varizeninstrumente

Varix Instruments
Instrumentos para varices
Instruments pour varices
Strumenti per varici



1/2

Varady 16-248-00-01

Varizenbesteck
Varicose Vein Probe Set
Juego para varices
Trousse à varices
Set di sonde per varici

komplett, in ovalem Metalletui
complete, in oval metal case
completo, en caja metálica oval
complète, boîte en métal ovale
completo, in scatola metallica ovale

Set bestehend aus
set including
juego compuesto de
set comprenant
set costituito da

16-248-01-07

16-248-02-07

16-248-03-07

16-248-04-07

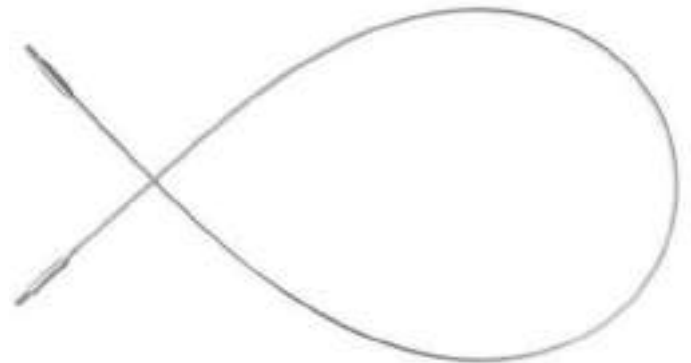

1/4



16-248-01-07

Ø 3,0 mm
Olive
Olive
Oliva
Olive
Oliva



16-248-02-07

Ø 4,0 mm
Olive
Olive
Oliva
Olive
Oliva



16-248-03-07

Ø 5,0 mm
Olive
Olive
Oliva
Olive
Oliva

16-248-04-07

Zugseil
Traction Cable
Cable de tracción
Cable tracteur
Fune di trazione
45 cm

Varizeninstrumente

Varix Instruments
Instrumentos para varices
Instruments pour varices
Strumenti per varici

Sonden, Watteträger, Spatel

Probes, Applicators, Spatulas
Sondas, Porta- algodones, Espátulas
Sondes, porte-cotons, spatules
Sonde, portacotoni, spatole

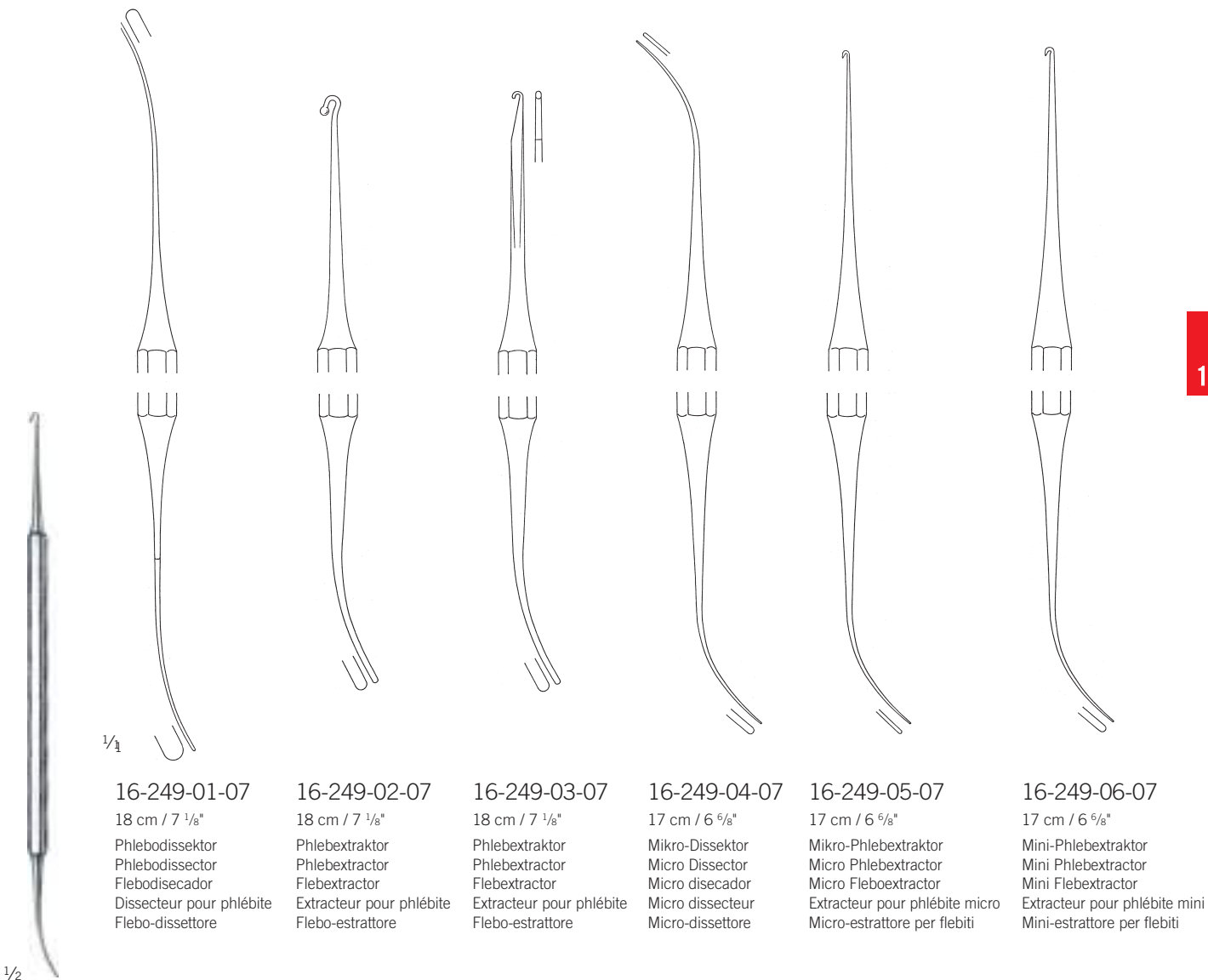
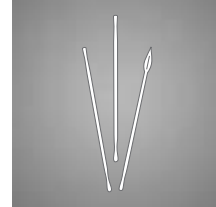

1/4

16-249-01-07

18 cm / 7 1/8"

Phlebodissektor
Phlebodissector
Flebodisecador
Dissecteur pour phlébite
Flebo-dissetto

16-249-02-07

18 cm / 7 1/8"

Phlebextraktor
Phlebextractor
Flebextractor
Extracteur pour phlébite
Flebo-estrattore

16-249-03-07

18 cm / 7 1/8"

Phlebextraktor
Phlebextractor
Flebextractor
Extracteur pour phlébite
Flebo-estrattore

16-249-04-07

17 cm / 6 6/8"

Mikro-Dissektor
Micro Dissector
Micro disecador
Micro dissecteur
Micro-dissetto

16-249-05-07

17 cm / 6 6/8"

Mikro-Phlebextraktor
Micro Phlebextractor
Micro Fleboextractor
Extracteur pour phlébite micro
Micro-estrattore per flebiti

16-249-06-07

17 cm / 6 6/8"

Mini-Phlebextraktor
Mini Phlebextractor
Mini Flebextractor
Extracteur pour phlébite mini
Mini-estrattore per flebiti

1/2

Varady

16-249-01-07 -

16-249-06-07

Varizeninstrumente

Varix Instruments
Instrumentos para varices
Instruments pour varices
Strumenti per varici



1/2

Nabattoff 16-250-00-01

Varizenbesteck
Varicose Vein Probe Set
Juego para varices
Trousse à varices
Set di sonde per varici

komplett, in ovalem Metalletui
complete, in oval metal case
completo, en caja metálica oval
complète, boîte en métal ovale
completo, in scatola metallica ovale

Set bestehend aus
set including
juego compuesto de
set comprenant
set costituito da

16-250-02-04

16-250-03-07

16-250-06-07

16-250-09-07

16-250-12-07

16-250-80-07

16-250-90-07



1/1

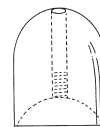

16-250-02-04

16-250-03-07

16-250-06-07

16-250-09-07

16-250-12-07

Kunststoffspitze
Plastic Probe Tip
Punta plástica
Pointe en plastique
Punta di plastica

Ø 3,0 mm
Olive
Olive
Oliva
Olive
Oliva

Ø 6,0 mm
Olive
Olive
Oliva
Olive
Oliva

Ø 9,0 mm
Olive
Olive
Oliva
Olive
Oliva

Ø 12,0 mm
Olive
Olive
Oliva
Olive
Oliva

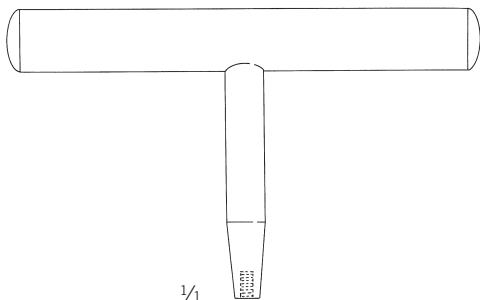

1/1

16-250-80-07

T-Griff
Handle, T-form
Mango
Manche tracteur
Mango solo

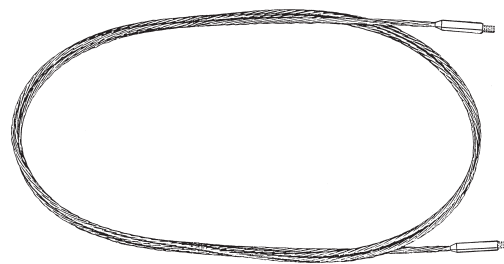

16-250-90-07

Zugseil
Traction Cable
Cable de tracción
Cable tracteur
Fune di trazione
90 cm

Nicht im Set enthalten
Not included in the set
No incluido en el juego
Non contenu dans le set
Non contenuto nel set

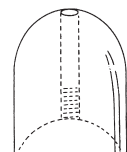

16-250-15-07

Ø 15,0 mm
Olive
Olive
Oliva
Olive
Oliva

Ringstripper

Ring Strippers
Fleboextractores
Strippers à anneau
Stripper anello

Sonden, Watteträger, Spatel

Probes, Applicators, Spatulas
Sondas, Porta- algodones, Espátulas
Sondes, porte-cotons, spatules
Sonde, portacotoni, spatole

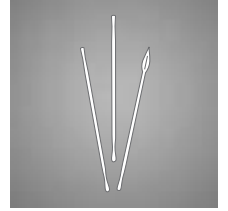

16-251-02-01
Ø 2,0 mm



16-251-03-01
Ø 3,0 mm



16-251-04-01
Ø 4,0 mm



16-251-06-01
Ø 6,0 mm



16-251-07-01
Ø 7,0 mm



16-251-08-01
Ø 8,0 mm

1/1



16-251-10-01
Ø 10 mm

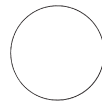

16-251-12-01
Ø 12 mm

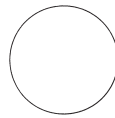

16-251-14-01
Ø 14 mm

1/2

Vollmar

16-251-02-01 -
16-251-14-01

50 cm / 19 5/8"

stumpf
blunt
romo
mousse
smusso



1/2

16-251-30-01

11,5 cm / 4 4/8"

Handgriff für Ringstripper nach Vollmar

Handle for Vollmar Ring Stripper

Mango para Vollmar fleboextractor

Manche pour stripper à anneau selon Vollmar

Manico per stripper anello di Vollmar*

➔ 16-251-02-01-
16-251-14-01

16

Watteträger

Cotton Applicators

Porta algodones

Porte-cotons

Portacottone

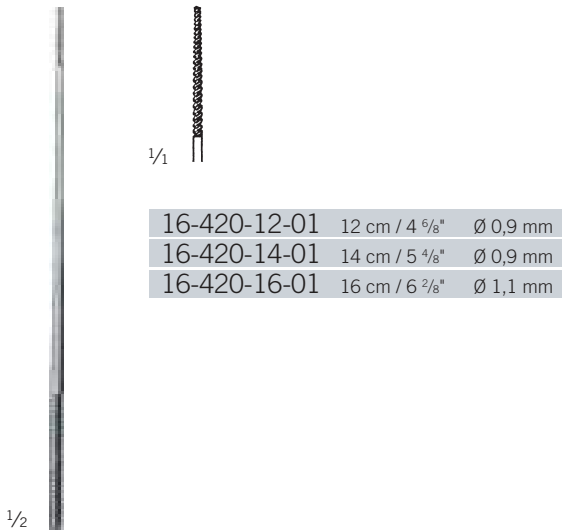

16-420-12-01	12 cm / 4 ⁶ / ₈ "	Ø 0,9 mm
16-420-14-01	14 cm / 5 ⁴ / ₈ "	Ø 0,9 mm
16-420-16-01	16 cm / 6 ² / ₈ "	Ø 1,1 mm

Farrell
16-420-12-01 -
16-420-16-01

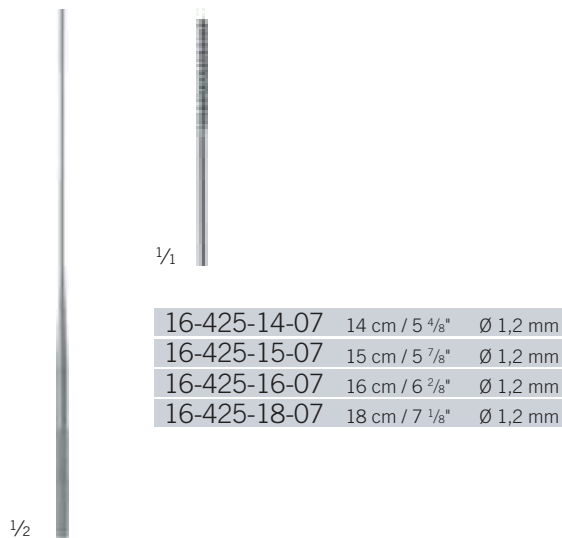

16-425-14-07	14 cm / 5 ⁴ / ₈ "	Ø 1,2 mm
16-425-15-07	15 cm / 5 ⁷ / ₈ "	Ø 1,2 mm
16-425-16-07	16 cm / 6 ² / ₈ "	Ø 1,2 mm
16-425-18-07	18 cm / 7 ¹ / ₈ "	Ø 1,2 mm

Farrell
16-425-14-07 -
16-425-18-07

3-kant
triangular
triangulair
triangulaires
triangolare

Diagnostik
Diagnostics
Diagnóstico
Diagnostic
Diagnostica

17

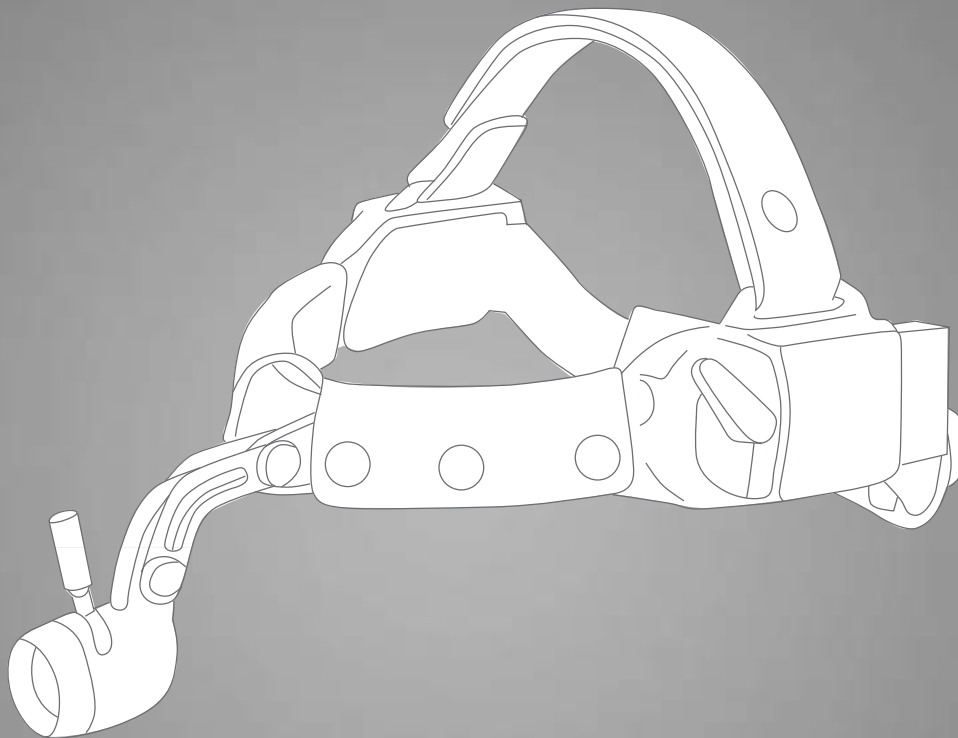

Informationen zu den KLS-Martin-Stirnleuchten entnehmen Sie bitte der separaten Broschüre „MedLED Sapphire™/MedLED Onyx™“.

Please refer to the separate brochure for information about KLS-Martin headlights “MedLED Sapphire™/MedLED Onyx™”.

Encontrará información sobre las lámparas frontal de KLS-Martin en el folletos individual “MedLED Sapphire™/MedLED Onyx™”.

Veillez vous reporter au brochure séparée pour obtenir des informations détaillées relatives aux lampes frontales KLS Martin « MedLED Sapphire™/MedLED Onyx™ » .

Per informazioni sulle lampada frontale di KLS Martin, consultare le brochure separate KLS Martin “MedLED Sapphire™/MedLED Onyx™”.

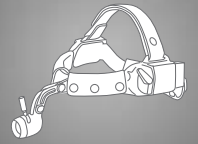

18

Sauger, Kanülen
Trocars, Suction Tubes, Cannulas
Trócares, Tubos de Aspiración, Cánulas
Trocarts, Tubes d'aspiration, Canules
Trequarti, Tubi d'aspirazione, Cannule

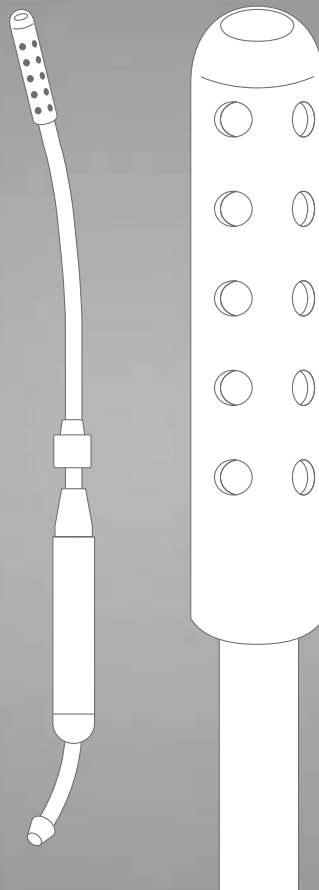

Trokare

Trocars
Trócares
Trocarts
Trequarti



Universal
18-306-04-07
14 cm / 5 $\frac{4}{8}$ "

mit 4 Trokaransätzen
with 4 trocar tips
con 4 puntas de trocar
avec 4 embouts de trocarts
con 4 punte di trequarti

Ø 1,7 / 3,0 / 4,5 / 6,0 mm



Nelson
18-348-07-01 -
18-352-11-01

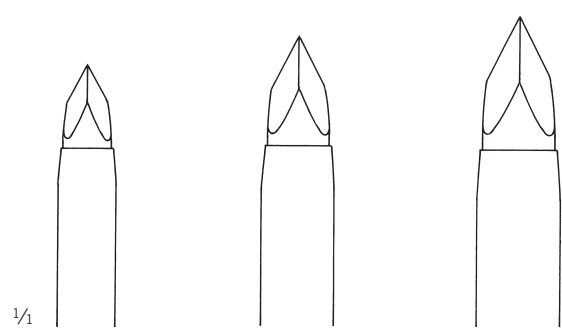

Fig. 1
18-348-07-01
21 cm / 8 $\frac{2}{8}$ "
Ø 7,5 mm

Fig. 2
18-350-09-01
21 cm / 8 $\frac{2}{8}$ "
Ø 9,5 mm

Fig. 3
18-352-11-01
21 cm / 8 $\frac{2}{8}$ "
Ø 11 mm

Saugrohre

Suction Cannulas
Tubos de aspiración
Tubes d'aspiration
Tubi d'aspirazione

Sauger, Kanülen

Trocars, Suction Tubes, Cannulas
Trócares, Tubos de Aspiración, Cánulas
Trocarts, Tubes d'aspiration, Canules
Trequarti, Tubi d'aspirazione, Cannule

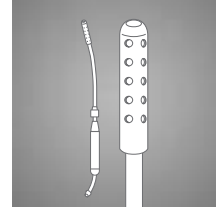

1/2

45°

90°

45°

60°

90°

18-510-33-07 -
18-511-50-07

pädiatrische Sauger, mit perforierter Schraubspitze
pediatric suction tubes, with perforated screw tip
tubos de aspiración para niños, con punta perforada y roscada
tubes d'aspiration pour enfants, avec pointe perforée et fileté
tubi di aspirazione pediatrici, con punta perforata e filetta

18-510-33-07	45°	18 cm / 7 1/8"	Ø 3,3 mm
18-510-50-07			Ø 5,0 mm
18-511-33-07	90°	16 cm / 6 2/8"	Ø 3,3 mm
18-511-50-07			Ø 5,0 mm

18-512-33-07 -
18-514-50-07

pädiatrische Sauger
pediatric suction tubes
tubos de aspiración para niños
tubes d'aspiration pour enfants
tubi di aspirazione

18-512-33-07	45°	21 cm / 8 2/8"	Ø 3,3 mm
18-512-50-07			Ø 5,0 mm
18-513-33-07	60°	18 cm / 7 1/8"	Ø 3,3 mm
18-513-50-07			Ø 5,0 mm
18-514-33-07	90°	15 cm / 5 7/8"	Ø 3,3 mm
18-514-50-07			Ø 5,0 mm

Sauger

Suction Tubes

Tubos de aspiración

Tubes d'aspiration

Tubi d'aspirazione

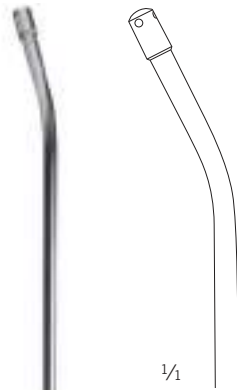

1/2

18-516-60-07

39 cm / 15 2/8"

Ø 6 mm

MIC-Sauger mit Saugunterbrecher

MIS Suction cannulas with suction stop

Cánulas de aspiración CMI con interrupción de succión

Canules d'aspiration CMI avec interruption de l'aspiration

Canulle di aspirazione CMI con arresto aspirazione



Adson

18-521-21-01

20 cm / 7 7/8"

Ø 4 mm



Frazier

18-522-10-01

24 cm / 9 4/8"

Ø 3,3 mm

Sauger, Saugrohre

Suction Tubes, Suction Tubes

Tubos de aspiración, Tubos de aspiración

Canules d'aspiration, Tubes d'aspiration

Cannula d'aspirazione, Tubi d'aspirazione

Sauger, Kanülen

Trocars, Suction Tubes, Cannulas

Trócares, Tubos de Aspiración, Cánulas

Trocarts, Tubes d'aspiration, Canules

Trequarti, Tubi d'aspirazione, Cannule

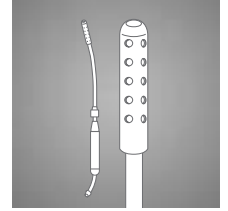

1/2

	Arbeitslänge working length largo útil longueur utile lunghezza utile	
18-523-06-01	130 mm	Ø 2,0 mm
18-523-07-01	130 mm	Ø 2,3 mm
18-523-08-01	130 mm	Ø 2,7 mm
18-523-09-01	130 mm	Ø 3,0 mm
18-523-10-01	130 mm	Ø 3,3 mm
18-523-11-01	130 mm	Ø 3,6 mm
18-523-12-01	130 mm	Ø 4,0 mm
18-523-13-01	130 mm	Ø 5,0 mm

Frazier

18-523-06-01 -

18-523-13-01

19,5 cm / 7 5/8"



1/2

	Arbeitslänge working length largo útil longueur utile lunghezza utile	
18-524-15-01	110 mm	Ø 1,5 mm
18-524-20-01	110 mm	Ø 2,0 mm
18-524-25-01	110 mm	Ø 2,5 mm
18-524-30-01	110 mm	Ø 3,0 mm
18-524-40-01	110 mm	Ø 4,0 mm
18-524-50-01	110 mm	Ø 5,0 mm

Fergusson

18-524-15-01 -

18-524-50-01

18 cm / 7 1/8"

Saugrohre

Suction Cannulas
 Tubos de aspiración
 Tubes d'aspiration
 Tubi d'aspirazione



1/2

Poppen
 18-525-06-01 -
 18-525-12-01
 18 cm / 7 1/8"

	Arbeitslänge working length largo útil longueur utile lunghezza utile	
18-525-06-01	90 mm	Ø 2,0 mm
18-525-08-01	90 mm	Ø 2,6 mm
18-525-10-01	90 mm	Ø 3,3 mm
18-525-12-01	90 mm	Ø 4,0 mm



1/2

Zoellner
 18-526-00-01 -
 18-526-12-01
 Saugkanüle
 Suction cannula
 Tubo de aspiración
 Tube d'aspiration
 Tubo di aspirazione

Saugaufsatz Suction tip Punta de succión Pointe de succion Punta per aspirazione	
18-526-05-01	Ø 0,5 mm
18-526-07-01	Ø 0,7 mm
18-526-09-01	Ø 0,9 mm
18-526-12-01	Ø 1,2 mm

Zoellner
 18-526-00-01
 Saugkanüle, allein
 Suction cannula, only
 Tubo de aspiración, solo
 Tube d'aspiration, seul
 Tubo di aspirazione, solo

Sauger, Saugrohre

Suction Tubes, Suction Tubes

Tubos de aspiración, Tubos de aspiración

Canules d'aspiration, Tubes d'aspiration

Cannula d'aspirazione, Tubi d'aspirazione

Sauger, Kanülen

Trocars, Suction Tubes, Cannulas

Trócares, Tubos de Aspiración, Cánulas

Trocarts, Tubes d'aspiration, Canules

Trequarti, Tubi d'aspirazione, Cannule

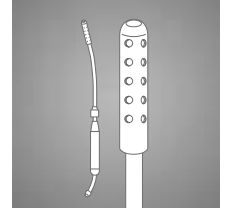

1/2

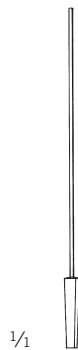

1/1

18-527-04-01	Ø 0,4 mm
18-527-06-01	Ø 0,6 mm
18-527-08-01	Ø 0,8 mm



1/2

Wullstein

18-527-00-01

14 cm / 5 4/8"

komplett mit Griff und drei Aufsätzen
complete, with handle and 3 tips
completo, con mango y 3 puntas
complet, avec manche et 3 pointes
completo, con manico e 3 punte

18-527-04-01 - 18-527-08-01

4,5 cm / 1 6/8"

Mikro-Saugkanüle
Micro suction cannula
Micro-tubo de aspiración
Micro-tube d'aspiration
Micro-tubo di aspirazione

Wullstein

18-527-01-01

14 cm / 5 4/8"

Handgriff mit Rohr, allein
Handle with tube, only
Mango con tubo, solo
Manche avec tube, seul
Manico con tubo, solo



18-527-00-01



1/2

	Arbeitslänge working length largo útil longueur utile lunghezza utile	
18-528-10-01	75 mm	Ø 1,0 mm
18-528-15-01	75 mm	Ø 1,5 mm
18-528-20-01	75 mm	Ø 2,0 mm

Baron-Schuknecht

18-528-10-01 -

18-528-20-01

mit Unterbrecher
with finger cut-off
con placa interruptor
avec plaque interrupteur
con placa interruttore

Saugrohre

Suction Tubes

Tubos de aspiración

Tubes d'aspiration

Tubi d'aspirazione



1/2

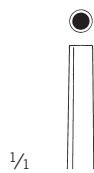

1/4

18-529-30-07

16,5 cm / 6 4/8"

Ø 3,0 mm

Arbeitslänge
working length
largo útil
longueur utile
lunghezza utile

110 mm



18-529-35-07

16,5 cm / 6 4/8"

Ø 3,5 mm

Arbeitslänge
working length
largo útil
longueur utile
lunghezza utile

110 mm



18-529-45-07

18 cm / 7 1/8"

Ø 4,5 mm

Arbeitslänge
working length
largo útil
longueur utile
lunghezza utile

130 mm



1/2

Luer

18-529-30-07 -
18-529-45-07

konisch
conical
cónico
conique
conico

18-531-01-07

Saughandgriff für Tonsillenkanüle

Suction handle for tonsil cannula

Mango de aspiración para
cánula para amígdalas

Poignée d'aspiration pour
aiguille pour amygdales

Impugnatura di aspirazione
per cannula per tonsille



**18-640-20-07,
18-641-20-07,
18-642-20-07**

Sauger, Saugrohre

Suction Tubes, Suction Tubes

Tubos de aspiración, Tubos de aspiración

Canules d'aspiration, Tubes d'aspiration

Cannula d'aspirazione, Tubi d'aspirazione

Sauger, Kanülen

Trocars, Suction Tubes, Cannulas

Trócares, Tubos de Aspiración, Cánulas

Trocarts, Tubes d'aspiration, Canules

Trequarti, Tubi d'aspirazione, Cannule

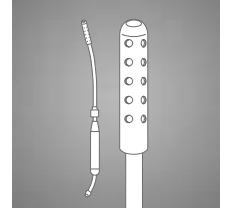

1/2

Landolt
18-533-01-07

25 cm / 9 7/8"

Ø 3,2 mm

Sauger für Hypophyse
Suction tube for pituitary
Aspirador para pituitaria
Tube d'aspiration pour hypophyse
Tubo di aspirazione per ipofisi



1/2

Cerullo
18-535-00-07

Saugventil
Suction valve
Válvula de aspiración
Vanne d'aspiration
Valvola di aspirazione



1/2

Yasargil
18-540-15-01 -
18-540-35-01

17 cm / 6 5/8"

Arbeitslänge
working length
largo útil
longueur utile
lunghezza utile

150 mm

18-540-15-01	Ø 1,5 mm
18-540-20-01	Ø 2,0 mm
18-540-25-01	Ø 2,5 mm
18-540-35-01	Ø 3,5 mm

Sauger

Suction Tubes

Tubos de aspiración

Tubes d'aspiration

Tubi d'aspirazione



1/2

Baby-Yankauer
18-542-21-01
21 cm / 8 ²/₈"

1/2

Yankauer
18-543-27-01
31 cm / 12 ²/₈"
komplett, mit Saugspitze
und Schlaucholive
complete, with suction tip
and connector
completo, con punta di succion
et raccord
complet, avec pointe de succion
et raccord
completi, con punte d'aspirazione
e raccordo

1/2

De Bakey-Adson
18-544-16-07 = 16 cm / 6 ²/₈"
18-544-20-07 = 20 cm / 7 ⁷/₈"
Ø 4 mm

1/2

De Bakey-Adson
18-544-28-07
28 cm / 6 ²/₈"
Ø 9 mm

Sauger

Suction Tubes
Tubos de aspiración
Tubes d'aspiration
Tubi d'aspirazione

Sauger, Kanülen

Trocars, Suction Tubes, Cannulas
Trócares, Tubos de Aspiración, Cánulas
Trocarts, Tubes d'aspiration, Canules
Trequarti, Tubi d'aspirazione, Cannule

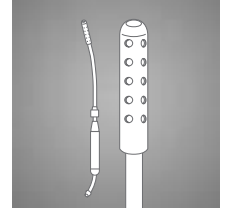

1/2



1/2

Fig. 0
18-545-10-01
10 cm / 3 7/8"



Fig. 1
18-545-11-01
10 cm / 3 7/8"



Fig. 2
18-545-12-01
10 cm / 3 7/8"



Fig. 3
18-545-13-01
13,5 cm / 5 3/8"



1/2



1/2



1/2

Yankauer

18-545-00-01

31 cm / 12 2/8"

komplett, mit Griff, 4 Saugrohren Fig. 0/1/2/3, Saugspitze und Schlaucholive

complete, with handle, 4 tubes fig. 0/1/2/3, suction tip and tube connector

completo, con mango, 4 tubos, fig. 0/1/2/3, punta de succión y conector para tubos

complet, avec manche, 4 tubes, fig. 0/1/2/3, pointe de succion et raccord ou tubes

completi, con manico, 4 tubi, fig. 0/1/2/3, punta per aspirazione e raccordo per tubi

18-545-00-01

Set bestehend aus:

Set consisting of:

Juego formado por:

Set composé de:

Set composto da:

18-545-01-01

18-545-02-01

18-545-10-01

18-545-11-01

18-545-12-01

18-545-13-01

18-545-15-01

18-545-01-01

15 cm / 5 7/8"

Handgriff

Handle

Mango

Manche

Manico

18-545-02-01

2,5 cm / 1"

Schlaucholive

Olive

Oliva

Oliva

Oliva

18-545-15-01

Saugspitze

suction tip

punta de succión

pointe de succion

punta per aspirazione

Sauger

Suction Tubes

Tubos de aspiración

Tubes d'aspiration

Tubi d'aspirazione



1/2

Baby-Poole
18-548-19-01
19 cm / 7 4/8"
Ø 6 mm



1/2

Baby-Poole
18-549-19-01
19 cm / 7 4/8"
Ø 6 mm



1/2

Poole
18-550-22-01
24 cm / 9 4/8"
Ø 10 mm



1/2

Poole
18-551-22-01
25 cm / 9 7/8"
Ø 8 mm

Sauger

Suction Tubes
Tubos de aspiración
Tubes d'aspiration
Tubi d'aspirazione

Sauger, Kanülen

Trocars, Suction Tubes, Cannulas
Trócares, Tubos de Aspiración, Cánulas
Trocarts, Tubes d'aspiration, Canules
Trequarti, Tubi d'aspirazione, Cannule

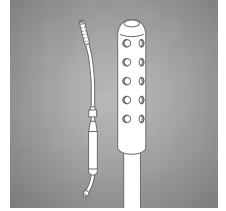

1/2

	Saugrohr Suction tube Tubo de aspiración Tube d'aspiration Tubo di aspirazione	Spülrohr Irrigation tube Tubo de irrigación Tube d'irrigation Tubo d'irrigazione
18-553-09-07	Ø 0,9 mm	Ø 0,7 mm
18-554-09-07	Ø 1,2 mm	Ø 0,9 mm
18-555-09-07	Ø 1,5 mm	Ø 1,2 mm



1/2

House
18-553-09-07 -
18-555-09-07

17 cm / 6 5/8"

Saugrohr
Suction tube
Tubo de aspiración
Tube d'aspiration
Tubo di aspirazione

House
18-556-06-07

4,5 cm / 1 6/8"

Saugadapter
Suction adapter
Adaptador de aspiración
Adaptateur d'aspiration
Adattatore di aspirazione

Sauger

Suction Tubes

Tubos de aspiración

Tubes d'aspiration

Tubi d'aspirazione



1/2

Cooley
18-561-35-01
36 cm / 14 1/8"
Ø 8 mm



1/2

Cooley
18-563-31-01
31 cm / 12 2/8"
Ø 10 mm

mit perforierter Schraubspitze
with perforated screw tip
con punta perforada y roscada
avec pointe perforée et filetée
con punta perforata e filetta



1/2

Cooley
18-565-30-01
31 cm / 12 2/8"
Ø 7 mm

mit perforierter Schraubspitze
with perforated screw tip
con punta perforada y roscada
avec pointe perforée et filetée
con punta perforata e filetta



1/2

Cooley
18-567-33-01
36 cm / 14 1/8"
Ø 8 mm

mit perforierter Schraubspitze
with perforated screw tip
con punta perforada y roscada
avec pointe perforée et filetée
con punta perforata e filetta

Sauger

Suction Tubes

Tubos de aspiración

Tubes d'aspiration

Tubi d'aspirazione

Sauger, Kanülen

Trocars, Suction Tubes, Cannulas

Trócares, Tubos de Aspiración, Cánulas

Trocarts, Tubes d'aspiration, Canules

Trequarti, Tubi d'aspirazione, Cannule

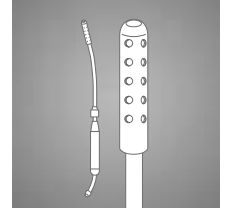

1/2

18-568-28-07

28 cm / 11"

Ø 6 mm

mit perforierter Schraubspitze
with perforated screw tip
con punta perforada y roscada
avec pointe perforée et filetée
con punta perforata e filetta



1/2

18-568-30-07

30 cm / 11 6/8"

Ø 6 mm

mit perforierter Schraubspitze
with perforated screw tip
con punta perforada y roscada
avec pointe perforée et filetée
con punta perforata e filetta

Sauger

Suction Tubes

Tubos de aspiración

Tubes d'aspiration

Tubi d'aspirazione



1/2

Nuboer
18-569-21-01

21 cm / 8 2/8"

Ø 6 mm

runde Öffnung
round opening
abertura redonda
ouverture ronde
apertura rotonda



1/2

Nuboer
18-571-21-01

21 cm / 8 2/8"

Ø 6 mm

ovale Öffnung
oval opening
abertura ovalada
ouverture ovale
apertura ovale



1/2

Jamieson
18-572-05-07 -
18-572-15-07

27 cm / 10 6/8"

18-572-05-07	Ø 0,5 mm
18-572-10-07	Ø 1,0 mm
18-572-15-07	Ø 1,5 mm



1/2

Jamieson
18-573-05-07 -
18-573-10-07

27 cm / 10 6/8"

18-573-05-07	Ø 0,5 mm
18-573-10-07	Ø 1,0 mm

Sauger, Saugrohre

Suction Tubes
Tubos de aspiración
Tubes d'aspiration
Tubi d'aspirazione

Sauger, Kanülen

Trocars, Suction Tubes, Cannulas
Trócares, Tubos de Aspiración, Cánulas
Trocarts, Tubes d'aspiration, Canules
Trequarti, Tubi d'aspirazione, Cannule

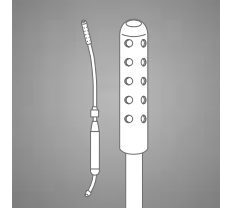

1/1 ○

18-575-05-01
9 cm / 3 4/8"
Ø 1,5 mm

○

18-575-06-01
9 cm / 3 4/8"
Ø 2,0 mm

1/1 ○

18-575-07-01
9 cm / 3 4/8"
Ø 2,5 mm

○

18-575-08-01
9 cm / 3 4/8"
Ø 3,5 mm

Spitze seitlich perforiert
tip laterally perforated
punta perforada lateralmente
pointe côté perforée
punta con perforazione laterale



18-575-24-01



1/2

Coupland
18-575-24-01

17 cm / 6 6/8"

Handgriff mit Schlauchansatz
Handle with connector
Mango con conexión para tubos
Manche avec connection pour tubes
Manico con raccordo per tubi



1/2

Byrd
18-577-01-01 -
18-577-03-01

21,5 cm / 8 4/8"

○

18-577-01-01
Ø 3,0 mm

○

18-577-02-01
Ø 3,5 mm

1/1 ○

18-577-03-01
Ø 4,3 mm



1/2

Cogswell
18-579-23-01

24,5 cm / 9 5/8"

Ø 3,8 mm

mit Unterbrecher
with finger cut-off
con placa desconectadona
avec plaque interrupteur
con placa interruttore

Führungsnadeln

Guide Needles

Agujas de guía

Aiguilles d'introduction

Aghi conduttori

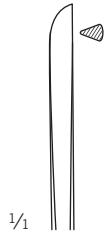

18-580-08-07	8 CH
18-580-10-07	10 CH
18-580-12-07	12 CH
18-580-14-07	14 CH
18-580-16-07	16 CH
18-580-18-07	18 CH

1/2

Redon
18-580-08-07 -
18-580-18-07

19,5 cm / 7 5/8"

mit Schraubgewinde
threaded end
roscada
filetée
con filetto

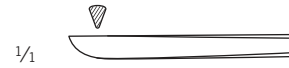

18-581-08-07	8 CH
18-581-10-07	10 CH
18-581-12-07	12 CH
18-581-14-07	14 CH
18-581-16-07	16 CH
18-581-18-07	18 CH

1/2

Redon
18-581-08-07 -
18-581-18-07

14 cm / 5 4/8"

mit Schraubgewinde
threaded end
roscada
filetée
con filetto

Führungsnadeln

Guide Needles

Agujas de guía

Aiguilles d'introduction

Aghi conduttori

Sauger, Kanülen

Trocars, Suction Tubes, Cannulas

Trócares, Tubos de Aspiración, Cánulas

Trocarts, Tubes d'aspiration, Canules

Trequarti, Tubi d'aspirazione, Cannule

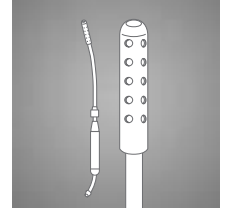

1/1



18-583-08-07	8 CH
18-583-10-07	10 CH
18-583-12-07	12 CH
18-583-14-07	14 CH
18-583-16-07	16 CH
18-583-18-07	18 CH

1/2

Redon

18-583-08-07 -
18-583-18-07

19,5 cm / 7 5/8"

mit Schraubgewinde

threaded end

roscada

filetée

con filetto



1/1

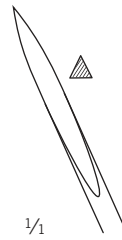

18-584-08-07	8 CH
18-584-10-07	10 CH
18-584-12-07	12 CH
18-584-14-07	14 CH
18-584-16-07	16 CH
18-584-18-07	18 CH

1/2

Redon

18-584-08-07 -
18-584-18-07

19,5 cm / 7 5/8"

mit Schraubgewinde

threaded end

roscada

filetée

con filetto

18

Injektionskanülen

Hypodermic Needles

Agujas hipodérmicas

Aiguilles hypodermiques

Cannule per iniezione



18-606-00-01

Pudendus-Anästhesiekanüle
Pudendus Anaesthesia Needle
Cánula para anestesia transvaginal
Canule pour anesthésie transvaginale
Cannula per anestesia trasvaginale

komplett mit Nadel
complete with needle
completo con aguja
complet avec aiguille
completa con ago

18-606-01-01

Nadel
Cannula
Cánula
Canule
Cannula

1/2

Ø 1,00 x 185 mm

18-606-00-01 -
18-606-01-01

18 cm / 7"

Luer-Lock Ansatz
Luer Lock connection
conexión Luer-Lock
raccordo Luer-Lock
raccordo Luer-Lock



1/2

18-610-12-07 -
18-610-15-07

Venenkanülen
Vein Cannulas
Cánulas para venas
Canules veineuses
Cannule per vene

18-610-12-07	1,2 x 80 mm
--------------	-------------

18-610-15-07	1,5 x 80 mm
--------------	-------------



1/2

18-611-20-07 -
18-696-06-01

Heparinnadel, Luer-Lock-Ansatz
Heparin Flushing Needle, Luer Lock connection
Aguja para heparin, conexión Luer-Lock
Aiguille pour héparine, raccord Luer-Lock
Ago per eparina, raccordo Luer-Lock

18-611-20-07	2,0 x 45 mm
--------------	-------------

18-611-30-07	3,0 x 45 mm
--------------	-------------

18-611-37-07	3,7 x 55 mm
--------------	-------------

18-611-50-07	5,0 x 60 mm
--------------	-------------

18-696-06-01	2,9 x 65 mm
--------------	-------------

Spezialkanülen

Special Needles
Agujas especiales
Aiguilles spéciales
Aghi speciali

Sauger, Kanülen

Trocars, Suction Tubes, Cannulas
Trocares, Tubos de Aspiración, Cánulas
Trocarts, Tubes d'aspiration, Canules
Trequarti, Tubi d'aspirazione, Cannule

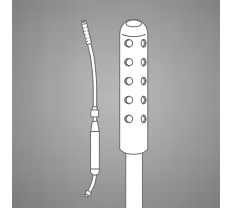

	Arbeitslänge working length largo útil longueur utile lunghezza utile	
18-632-12-07	76 mm	Ø 1,2 mm
18-632-14-07	76 mm	Ø 1,4 mm
18-632-16-07	76 mm	Ø 1,6 mm

mit Spezialspitze, Luer-Lock Ansatz
with special tip, Luer-Lock connection
con punta especial, conexión Luer-Lock
avec pointe spéciale, raccord Luer-Lock
con punta speciale, raccordo Luer-Lock

Tuohy

18-632-12-07 -
18-632-16-07

Lumbalpunktionskanüle
Lumbar Puncture Needle
Aguja para punción lumbar
Aiguille pour ponction lombaire
Cannula per puntura lumbale



1/2

Verhoeven

18-635-10-07
10 cm / 3 7/8"

Ø 1,5 mm
Saugkanüle
Suction cannula
Cánula de aspiración
Canule d'aspiration
Cannula di aspirazione

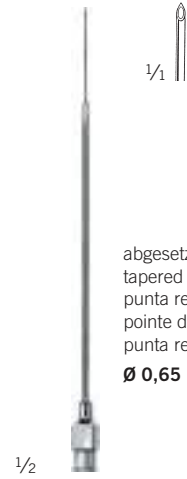

1/2

abgesetzte Spitze
tapered tip
punta reducida
pointe de reduction
punta redotta
Ø 0,65 mm

18-640-10-07

Luer-Lock Ansatz
Luer Lock connection
conexión Luer-Lock
raccord Luer-Lock
raccordo Luer-Lock

1/1



1/2

abgesetzte Spitze
tapered tip
punta reducida
pointe de reduction
punta redotta
Ø 0,80 mm



1/2

abgesetzte Spitze
tapered tip
punta reducida
pointe de reduction
punta ridotta
Ø 0,65 mm



1/2

18-641-20-07	Ø 1,0 mm
18-642-20-07	Ø 1,3 mm

18-640-15-07

Luer-Lock Ansatz
Luer Lock connection
conexión Luer-Lock
raccord Luer-Lock
raccordo Luer-Lock

18-640-20-07

Tonsillenkanüle, Luer-Lock-Ansatz
Tonsil cannula, Luer Lock connection
Cánula para amígdalas, conexión Luer-Lock
Aiguille pour amygdales, raccord Luer-Lock
Cannula per tonsille, raccordo Luer-Lock

18-641-20-07 -
18-642-20-07

Tonsillenkanüle, gewinkelt
Tonsil cannula, angled
Cánula para amígdalas, acodada
Aiguille pour amygdales, angulée
Cannula per tonsille, angolata

Saugkanülen, Injektionskanülen

Suction Cannulas, Hypodermic Needles

Cánulas de aspiración, Agujas hipodérmicas

Canules d'aspiration, Aiguilles hypodermiques

Cannule di aspirazione, Cannule per iniezione



1/2

18-645-15-07	Ø 1,5 mm
18-645-20-07	Ø 2,0 mm
18-645-25-07	Ø 2,5 mm
18-645-30-07	Ø 3,0 mm

Plester

18-645-15-07 -

18-645-30-07

19,5 cm / 7 5/8"

Saugkanüle

Suction cannula

Cánula de aspiración

Canule d'aspiration

Cannula di aspirazione

Ag



1/2

18-647-15-07	Ø 1,5 mm
18-647-20-07	Ø 2,0 mm

18-647-15-07 -

18-647-20-07

16 cm / 6 2/8"

Saugkanüle, biegsam

Suction cannula, malleable

Cánula de aspiración, maleable

Canule d'aspiration, malléable

Cannula di aspirazione, malleabile



1/2

Ø 2,0 mm

Arbeitslänge
working length
largo útil
longueur utile
lunghezza utile

100 mm

Luer-Lock Ansatz
Luer-Lock connection
conexión Luer-Lock
raccord Luer-Lock
raccordo Luer-Lock



1/2

Ø 2,0 mm

Arbeitslänge
working length
largo útil
longueur utile
lunghezza utile

120 mm

Luer-Lock Ansatz
Luer-Lock connection
conexión Luer-Lock
raccord Luer-Lock
raccordo Luer-Lock



1/2

18-691-15-07	Ø 1,5 mm
18-691-20-07	Ø 2,0 mm
18-691-25-07	Ø 2,5 mm
18-691-30-07	Ø 3,0 mm
18-691-40-07	Ø 4,0 mm

Verres

18-665-20-07

Insufflationskanüle

Insufflation Cannula

Cánula para insuflación

Canule pour insufflation

Cannula per insufflazione

Verres

18-666-20-07

Insufflationskanüle

Insufflation Cannula

Cánula para insuflación

Canule pour insufflation

Cannula per insufflazione

Vollmar

18-691-15-07 -

18-691-40-07

6 cm / 2 3/8"

Luer-Lock Ansatz

Luer-Lock connection

conexión Luer-Lock

raccord Luer-Lock

raccordo Luer-Lock

Gefäß-Spülkanülen, Leberpunktionskanülen

Vessel Irrigation Cannulas, Liver Puncture Needles

Cánulas para irrigación vascular, Aguja para punción del hígado

Canules pour irrigation vasculaire, Aiguilles pour ponction du foie

Cannule per irrigazione vascolare, Cannule per la puntura del fegato

Sauger, Kanülen

Trocars, Suction Tubes, Cannulas

Trócares, Tubos de Aspiración, Cánulas

Trocart, Tubes d'aspiration, Canules

Trequarti, Tubi d'aspirazione, Cannule

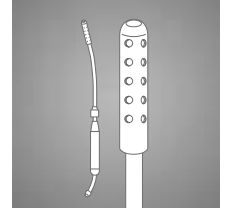

Ag

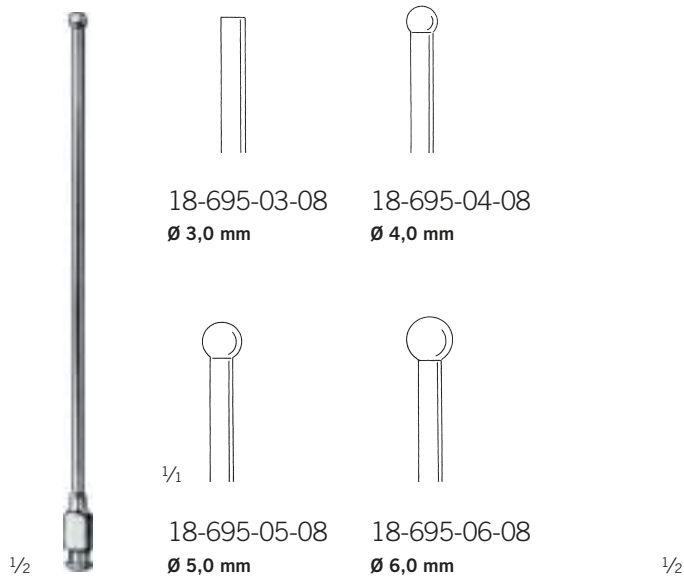

18-695-03-08

Ø 3,0 mm

18-695-04-08

Ø 4,0 mm

1/1

18-695-05-08

Ø 5,0 mm

18-695-06-08

Ø 6,0 mm

1/2

Ø 2,9 x 0,8 mm

mit Knopfende
button-ended
punta abotonada
aboutonné
con punta a bottone

Schmid

18-695-03-08 -

18-695-06-08

15 cm / 5 7/8"

biegsam, Luer-Lock Ansatz
malleable, Luer-Lock connection
maleable, conexión Luer-Lock
malléable, raccord Luer-Lock
malleabili, raccordo Luer-Lock

Mock

18-696-06-01

6,5 cm / 2 4/8"

Heparinnadel, Luer-Lock Ansatz
Heparin Flushing Needle, Luer Lock connection
Aguja para heparin, conexión Luer-Lock
Aiguille pour héparine, raccord Luer-Lock
Ago per eparina, raccordo Luer-Lock

18



1/2

	Arbeitslänge working length largo útil longueur utile lunghezza utile	
18-700-10-07	35 mm	Ø 1,0 mm
18-700-15-07	70 mm	Ø 1,0 mm
18-700-20-07	70 mm	Ø 1,2 mm
18-700-25-07	100 mm	Ø 1,2 mm
18-700-30-07	70 mm	Ø 1,4 mm
18-700-35-07	100 mm	Ø 1,4 mm
18-700-40-07	70 mm	Ø 1,6 mm
18-700-50-07	100 mm	Ø 1,8 mm

Menghini

18-700-10-07 -

18-700-50-07

für Leberblindpunktion, mit Stoppsonde
for liver blind puncture, with stopping probe
para punción ciega del hígado, con aguja limitadora
pour ponction aveugle du foie, avec clou d'arrêt
per puntatura con ago limitatore



	Arbeitslänge working length largo útil longueur utile lunghezza utile	
18-710-14-02	168 mm	Ø 1,4 mm
18-710-18-02	168 mm	Ø 1,8 mm

Menghini

18-710-14-02 -

18-710-18-02

für gezielte Leberpunktion
for controlled liver blind puncture
para punción controlada del hígado
pour ponction contrôlée du foie
per puntatura controllata del fegato

Verbindungsstücke, Hähne

Connecting Pieces

Piezas de conexión

Raccords

Raccordi



1/2

18-800-00-02

Zwischenstück
Connector
Conector
Raccord
Raccordo

LL = weiblich, RC = männlich
LL = female, RC = male
LL = hembra, RC = macho
LL = femelle, RC = mâle
LL = femminile, RC = maschile



1/2

18-802-00-02

Zwischenstück
Connector
Conector
Raccord
Raccordo

RC = weiblich, Luer = männlich
RC = female, Luer = male
RC = hembra, Luer = macho
RC = femelle, Luer = mâle
RC = femminile, Luer = maschile



1/2

18-804-00-02

Schlauchverbinder
Connector
Conector
Raccord
Raccordo

LL = männlich
LL = male
LL = macho
LL = mâle
LL = maschile



1/2

18-806-00-02

Schlauchverbinder
Connector
Conector
Raccord
Raccordo

LL = weiblich
LL = female
LL = hembra
LL = femelle
LL = femminile



1/2

18-825-01-02	Ø 2,5 / 4,0 mm
18-825-02-02	Ø 2,5 / 6,5 mm
18-825-03-02	Ø 3,0 / 9,0 mm

18-825-01-02 -
18-825-03-02

Katheteransatz, konisch
Catheter Fitting, conical
Adaptador para catéteres, cónico
Adaptateur pour cathéters, conique
Adattatore per cateteri, conico

Luer-Lock Ansatz = weiblich
Luer-Lock connection = female
conexión Luer-Lock = hembra
raccord Luer-LockL = femelle
raccordo Luer-Lock = femminile



1/2

18-830-00-02

Harnröhrenolive
Urethral Olive
Oliva uretral
Olive uréthrale
Oliva uretrale

LL = weiblich
LL = female
LL = hembra
LL = femelle
LL = femminile



1/2

18-840-00-02

Durchflußhahn
Stopcock
Llave
Robinet
Rubinetto

LL = weiblich/männlich
LL = female/male
LL = hembra/macho
LL = femelle/mâle
LL = femminile/maschile



1/2

18-845-00-02

Dreiwegehahn
3-Way Stopcock
Llave de 3 vías
Robinet à trois voies
Rubinetto a tre vie

1 x LL = männlich, 2 x LL = weiblich
1 x LL male, 2 x LL = female
1 x LL macho, 2 x LL = hembra
1 x LL mâle, 2 x LL = femelle
1 x LL maschile, 2 x LL = femminile



1/2

18-850-03-02 -
18-850-13-02

Anschlußstutzen
Connector
Conector
Raccord
Tubo di connessione

für Endotrachealkatheter
for trachea tubes
para tubos endo-traqueales
pour tubes endotrachéales
per tubi endotracheali

18-850-03-02	Ø 3,0 mm
18-850-04-02	Ø 4,0 mm
18-850-05-02	Ø 5,0 mm
18-850-06-02	Ø 6,0 mm
18-850-07-02	Ø 7,0 mm
18-850-08-02	Ø 8,0 mm
18-850-09-02	Ø 9,0 mm
18-850-10-02	Ø 10 mm
18-850-11-02	Ø 11 mm
18-850-12-02	Ø 12 mm
18-850-13-02	Ø 13 mm

Spritzen

Hypodermic Syringes

Jeringas

Seringues

Siringhe

Sauger, Kanülen

Trocars, Suction Tubes, Cannulas

Trócares, Tubos de Aspiración, Cánulas

Trocarts, Tubes d'aspiration, Canules

Trequarti, Tubi d'aspirazione, Cannule

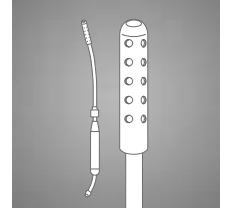

1/2

18-900-01-04	1 ml
18-900-02-04	2 ml
18-900-05-04	5 ml
18-900-10-04	10 ml
18-900-20-04	20 ml
18-900-50-04	50 ml

18-900-01-04 -
18-900-50-04

Glaszylinder, mit Luer Ansatz
Glass barrel, with Luer-connection
Cilindro de vidrio, con conexión Luer
Cylindre en verre, avec raccord Luer
Cilindro die vetro, con raccordo Luer



1/2

18-902-01-04	1 ml
18-902-02-04	2 ml
18-902-05-04	5 ml
18-902-10-04	10 ml
18-902-20-04	20 ml
18-902-50-04	50 ml

18-902-01-04 -
18-902-50-04

Ersatzzylinder, mit Luer Ansatz
Spare Barrels, with Luer-connection
Cilindros de repuesto, con conexión Luer
Cylindres de rechange, avec raccord Luer
Cilindri di ricambio, con raccordo Luer



1/2

18-910-01-04	1 ml
18-910-02-04	2 ml
18-910-05-04	5 ml
18-910-10-04	10 ml
18-910-20-04	20 ml
18-910-50-04	50 ml

18-910-01-04 -
18-910-50-04

Glaszylinder, mit Luer-Lock
Glass barrel, with Luer-Lock
Cilindro de vidrio, con Luer-Lock
Cylindre en verre, avec Luer-Lock
Cilindro die vetro, con Luer-Lock



1/2

18-912-01-04	1 ml
18-912-02-04	2 ml
18-912-05-04	5 ml
18-912-10-04	10 ml
18-912-20-04	20 ml
18-912-50-04	50 ml

18-912-01-04 -
18-912-50-04

Ersatzzylinder, mit Luer-Lock
Spare Barrels, with Luer-Lock
Cilindros de repuesto, con Luer-Lock
Cylindres de rechange, avec Luer-Lock
Cilindri di ricambio, con Luer-Lock

Spritzen

Hypodermic Syringes

Jeringas

Seringues

Siringhe



1/2

Glaszylinder, Luer-Lock Ansatz
bewegliche Ringe
Glass barrel, Luer Lock connection
moveable rings
Cilindro de vidrio, conexión Luer-Lock
anillos móviles
Cylindre en verre, avec raccord Luer-Lock
anneaux mobiles
Cilindro di vetro, con raccordo Luer-Lock
anelli mobili

18-915-02-04	2 ml
18-915-05-04	5 ml
18-915-10-04	10 ml

18-915-02-04 -
18-915-10-04

Dreiring-Spritze
3-Ring Syringe
Jeringa de tres anillos
Seringue à trois anneaux
Siringa da tre anelli



1/2

Luer-Lock Ansatz
Luer Lock connection
conexión Luer-Lock
avec raccord Luer-Lock
con raccordo Luer-Lock

18-917-02-04	2 ml
18-917-05-04	5 ml
18-917-10-04	10 ml

18-917-02-04 -
18-917-10-04

Ersatzzylinder
Spare Barrel
Cilindro de repuesto
Cylindre de rechange
Cilindro di ricambio



1/2

18-920-01-04	1 ml / 40 E
18-920-02-04	2 ml / 80 E

18-920-01-04 -
18-920-02-04

Insulinspritze
Insulin Syringe
Jeringa para insulina
Seringue pour insuline
Siringa per insulina

Glaszylinder, mit Luer Ansatz
Glass barrel, with Luer-connection
Cilindro de vidrio, con conexión Luer
Cylindre en verre, avec raccord Luer
Cilindro die vetro, con raccordo Luer



1/2

18-922-01-04	1 ml / 40 E
18-922-02-04	2 ml / 80 E

18-922-01-04 -
18-922-02-04

Ersatzzylinder, mit Luer Ansatz
Spare Barrels, with Luer-connection
Cilindros de repuesto con conexión Luer
Cylindres de rechange, avec raccord Luer
Cilindri di ricambio, con raccordo Luer

Spritzen

Hypodermic Syringes

Jeringas

Seringues

Siringhe

Sauger, Kanülen

Trocars, Suction Tubes, Cannulas

Trócares, Tubos de Aspiración, Cánulas

Trocarts, Tubes d'aspiration, Canules

Trequarti, Tubi d'aspirazione, Cannule

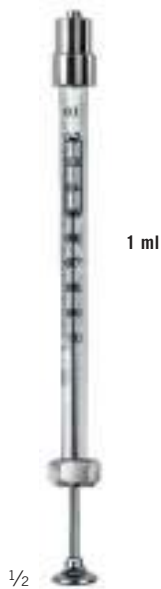
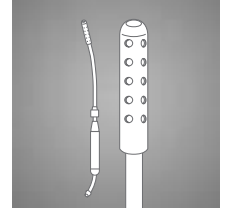

18-925-01-04

Tuberkulinspritze
Tuberculin Syringe
Jeringa para tuberculina
Seringue pour tuberculine
Siringa per tuberculina

Glaszylinder, Luer-Lock
Glass barrel, Luer-Lock
Cilindro de vidrio, Luer-Lock
Cylindre en verre, Luer-Lock
Cilindro die vetro, Luer-Lock



18-926-01-04

Ersatzzylinder, Luer-Lock
Spare Barrels, Luer-Lock
Cilindros de repuesto, Luer-Lock
Cylindres de rechange, Luer-Lock
Cilindri di ricambio, Luer-Lock

Wund- und Blasenspritzen

Wound and Bladder Syringes
 Jeringas para vejiga y heridas
 Seringues pour plaies et vessie
 Siringhe per vescica e ferite



18-930-05-04	50 ml
18-930-10-04	100 ml
18-930-15-04	150 ml
18-930-20-04	200 ml

1/2

Janet

18-930-05-04 -
 18-930-20-04

komplett, Glaszylinder,
 mit zwei auswechselbaren Aufsätzen
 complete, glass barrel,
 with two exchangeable tips
 completo, cilindro de vidrio,
 con dos puntas intercambiables
 complet, cylindre en verre,
 avec deux raccords interchangeable
 completa, cilindro di vetro,
 con due punte intercambiabili



18-932-05-04	50 ml
18-932-10-04	100 ml
18-932-15-04	150 ml
18-932-20-04	200 ml

1/2

Janet

18-932-05-04 -
 18-932-20-04

Ersatzzylinder
 Spare Barrel
 Cilindro de repuesto
 Cylindre de rechange
 Cilindro di ricambio



18-930-05-04
 18-930-10-04
 18-930-15-04
 18-930-20-04

19

Narkose
Anaesthesia
Anestesia
Anesthésie
Anestesia

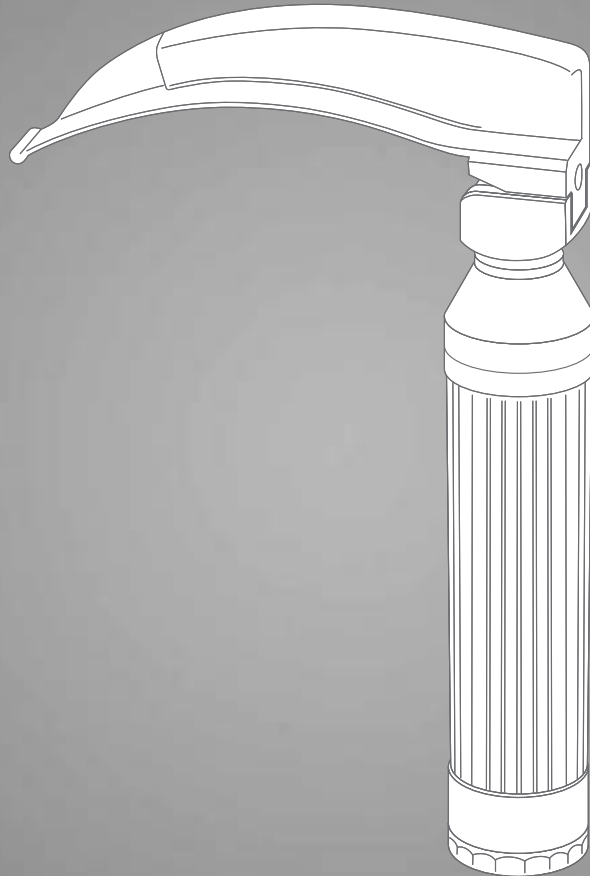

Kathetereinführzangen

Catheter Introducing Forceps

Pinzas para catéteres

Pinces pour introduire les sondes

Pinze per introdurre le sonde



1/1

19-301-15-07

15,5 cm / 6 1/8"

für Kleinkinder
for babies
para neonatales
pour nourrissons
per neonati



19-301-20-07

17,5 cm / 6 7/8"

für Kinder
for children
para niños
pour enfants
per bambini



19-303-25-07

20 cm / 7 7/8"

für Erwachsene
for adults
para adultos
pour adultes
per adulti



1/2

Magill

19-301-15-07 -

19-303-25-07



Miller/Miller-Baby
19-350-00-07 -
19-353-04-07

Miller 19-350-00-07

Set mit Batteriehandgriff (ohne Batterien) und drei Laryngoskopspateln Fig. 1 bis 3, komplett, in Etui

Set with battery handle (without batteries) and three laryngoscope blades fig. 1 to 3, complete, in case

Juego con mango de pilas (sin pilas) y tres hojas de laringoscopia fig. 1 a 3, completo, en estuche

Set avec manche à pile (sans pile) et trois spatules à laryngoscopie fig. 1 à 3, complet, en trousse

Set con manico a pila (senza pila) e tre spatole per laringoscopia fig. 1 fino a 3, completo, in scatola

Miller 19-351-00-07

Set mit Batteriehandgriff (ohne Batterien) und vier Laryngoskopspateln Fig. 1 bis 4, komplett, in Etui

Set with battery handle (without batteries) and four laryngoscope blades fig. 1 to 4, complete, in case

Juego con mango de pilas (sin pilas) y cuatro hojas de laringoscopia fig. 1 a 4, completo, en estuche

Set avec manche à pile (sans pile) et quatre spatules à laryngoscopie fig. 1 à 4, complet, en trousse

Set con manico a pila (senza pila) e quattro spatole per laringoscopia fig. 1 fino a 4, completo, in scatola

Miller-Baby 19-352-00-07

Set mit Batteriehandgriff (ohne Batterien) und zwei Laryngoskopspateln Fig. 0 und 1, komplett, in Etui

Set with battery handle (without batteries) and two laryngoscope blades fig. 0 and 1, complete, in case

Juego con mango de pilas (sin pilas) y dos hojas de laringoscopia fig. 0 y 1, completo, en estuche

Set avec manche à pile (sans pile) et deux spatules à laryngoscopie fig. 0 et 1, complet, en trousse

Set con manico a pila (senza pila) e due spatole per laringoscopia fig. 0 e 1, completo, in scatola



1/2

19-353-00-07

Fig. 0

für Säuglinge
for babies
para neonatales
pour nourrissons
per neonati

Nutzlänge
working length
largo útil
longueur utile
lunghezza operante
55 mm

19-353-01-07

Fig. 1

für Kinder
for children
para niños
pour enfants
per bambini

Nutzlänge
working length
largo útil
longueur utile
lunghezza operante
80 mm

19-353-02-07

Fig. 2

für Jugendliche
for adolescents
para adolescentes
pour adolescents
per adolescenti

Nutzlänge
working length
largo útil
longueur utile
lunghezza operante
130 mm

19-353-03-07

Fig. 3

für Frauen
for women
para mujeres
pour femmes
per donne

Nutzlänge
working length
largo útil
longueur utile
lunghezza operante
170 mm

19-353-04-07

Fig. 4

für Männer
for men
para hombres
pour hommes
per uomini

Nutzlänge
working length
largo útil
longueur utile
lunghezza operante
180 mm

Laryngoskope und Zubehör

Laryngoscopes and Accessories

Laringoscopios y accesorios

Laryngoscopes et accessoires

Laringoscopi ed accessori



Guedel-Negus
19-360-00-07 -
19-363-04-07

19-360-00-07

Set mit Batteriehandgriff (ohne Batterien) und drei Laryngoskopspateln Fig. 2 bis 4, komplett, in Etui

Set with battery handle (without batteries) and three laryngoscope blades fig. 2 to 4, complete, in case

Juego con mango de pilas (sin pilas) y tres hojas de laringoscopia fig. 2 a 4, completo, en estuche

Set avec manche à pile (sans pile) et trois spatules à laryngoscopie fig. 2 à 4, complet, en trousse

Set con manico a pila (senza pila) e tre spatole per laringoscopia fig. 2 fino a 4, completo, in scatola

19-361-00-07

Set mit Batteriehandgriff (ohne Batterien) und vier Laryngoskopspateln Fig. 1 bis 4, komplett, in Etui

Set with battery handle (without batteries) and four laryngoscope blades fig. 1 to 4, complete, in case

Juego con mango de pilas (sin pilas) y cuatro hojas de laringoscopia fig. 1 a 4, completo, en estuche

Set avec manche à pile (sans pile) et quatre spatules à laryngoscopie fig. 1 à 4, complet, en trousse

Set con manico a pila (senza pila) e quattro spatole per laringoscopia fig. 1 fino a 4, completo, in scatola



19-363-01-07

Fig. 1

für Kinder
for children
para niños
pour enfants
per bambini

Nutzlänge
working length
largo útil
longueur utile
lunghezza operante
70 mm



19-363-02-07

Fig. 2

für Jugendliche
for adolescents
para adolescentes
pour adolescents
per adolescenti

Nutzlänge
working length
largo útil
longueur utile
lunghezza operante
90 mm



19-363-03-07

Fig. 3

für Frauen
for women
para mujeres
pour femmes
per donne

Nutzlänge
working length
largo útil
longueur utile
lunghezza operante
110 mm

1/2



19-363-04-07

Fig. 4

für Männer
for men
para hombres
pour hommes
per uomini

Nutzlänge
working length
largo útil
longueur utile
lunghezza operante
135 mm



19-380-00-07

Set mit Batteriehandgriff (ohne Batterien) und drei Laryngoskopspateln Fig. 1 bis 3, komplett, in Etui

Set with battery handle (without batteries) and three laryngoscope blades fig. 1 to 3, complete, in case

Juego con mango de pilas (sin pilas) y tres hojas de laringoscopio fig. 1 a 3, completo, en estuche

Set avec manche à pile (sans pile) et trois spatules à laryngoscopie fig. 1 à 3, complet, en trousse

Set con manico a pila (senza pila) e tre spatole per laringoscopia fig. 1 fino a 3, completo, in scatola

19-384-00-07

Set mit Batteriehandgriff (ohne Batterien) und vier Laryngoskopspateln Fig. 1 bis 4, komplett, in Etui

Set with battery handle (without batteries) and four laryngoscope blades fig. 1 to 4, complete, in case

Juego con mango de pilas (sin pilas) y cuatro hojas de laringoscopio fig. 1 a 4, completo, en estuche

Set avec manche à pile (sans pile) et quatre spatules à laryngoscopie fig. 1 à 4, complet, en trousse

Set con manico a pila (senza pila) e quattro spatole per laringoscopia fig. 1 fino a 4, completo, in scatola

McIntosh
19-380-00-07 -
19-384-00-07



19-383-00-07

Fig. 0

für Säuglinge
for babies
para neonatales
pour nourrissons
per neonati

Nutzlänge
working length
largo útil
longueur utile
lunghezza operante
55 mm



19-383-01-07

Fig. 1

für Kinder
for children
para niños
pour enfants
per bambini

Nutzlänge
working length
largo útil
longueur utile
lunghezza operante
75 mm



19-383-02-07

Fig. 2

für Jugendliche
for adolescents
para adolescentes
pour adolescents
per adolescenti

Nutzlänge
working length
largo útil
longueur utile
lunghezza operante
90 mm



19-383-03-07

Fig. 3

für Frauen
for women
para mujeres
pour femmes
per donne

Nutzlänge
working length
largo útil
longueur utile
lunghezza operante
110 mm



19-383-04-07

Fig. 4

für Männer
for men
para hombres
pour hommes
per uomini

Nutzlänge
working length
largo útil
longueur utile
lunghezza operante
135 mm

1/2

Laryngoskope und Zubehör

Laryngoscopes and Accessories

Laringoscopios y accesorios

Laryngoscopes et accessoires

Laringoscopi ed accessori



Foregger
19-387-01-07 -
19-391-00-07

19-390-00-07

Set mit Batteriehandgriff (ohne Batterien) und drei Laryngoskopspateln Fig. 2 bis 4, komplett, in Etui

Set with battery handle (without batteries) and three laryngoscope blades fig. 2 to 4, complete, in case

Juego con mango de pilas (sin pilas) y tres hojas de laringoscopio fig. 2 a 4, completo, en estuche

Set avec manche à pile (sans pile) et trois spatules à laryngoscopie fig. 2 à 4, complet, en trousse

Set con manico a pila (senza pila) e tre spatole per laringoscopia fig. 2 fino a 4, completo, in scatola

19-391-00-07

Set mit Batteriehandgriff (ohne Batterien) und vier Laryngoskopspateln Fig. 1 bis 4, komplett, in Etui

Set with battery handle (without batteries) and four laryngoscope blades fig. 1 to 4, complete, in case

Juego con mango de pilas (sin pilas) y cuatro hojas de laringoscopio fig. 1 a 4, completo, en estuche

Set avec manche à pile (sans pile) et quatre spatules à laryngoscopie fig. 1 à 4, complet, en trousse

Set con manico a pila (senza pila) e quattro spatole per laringoscopia fig. 1 fino a 4, completo, in scatola



19-387-01-07

Fig. 1

für Kinder
for children
para niños
pour enfants
per bambini

Nutzlänge
working length
largo útil
longueur utile
lunghezza operante
70 mm



19-387-02-07

Fig. 2

für Jugendliche
for adolescents
para adolescentes
pour adolescents
per adolescenti

Nutzlänge
working length
largo útil
longueur utile
lunghezza operante
90 mm



19-387-03-07

Fig. 3

für Frauen
for women
para mujeres
pour femmes
per donne

Nutzlänge
working length
largo útil
longueur utile
lunghezza operante
110 mm



19-387-04-07

Fig. 4

für Männer
for men
para hombres
pour hommes
per uomini

Nutzlänge
working length
largo útil
longueur utile
lunghezza operante
135 mm

1/2



1/2

19-392-00-02

Handgriff für Warmlichtspatel und zwei Batterien Typ C (ohne Batterien)

Handle for warm light blade and two type C batteries (batteries not included)

Mango para espátula de luz cálida y dos pilas tipo C (sin pilas)

Manche pour spatule à lumière chaude et deux piles de type C (sans piles)

Manico per spatola a luce calda e due batterie tipo C (senza batterie)



1/1

19-395-00-04

Ersatzlampe groß, für Spatel

Spare bulb large, for blades

Bombilla de recambio grande, para hojas

Ampoule de rechange grande, pour spatule

Lampadina di ricambio grande, per spatola



19-353-04-07,

19-363-02-07,

19-363-03-07,

19-363-04-07,

19-383-01-07,

19-383-02-07,

19-383-03-07,

19-383-04-07,

19-387-02-07,

19-387-03-07,

19-387-04-07



1/1

19-395-01-04

Ersatzlampe klein, für Spatel

Spare bulb small, for blades

Bombilla de recambio pequeña, para hojas

Ampoule de rechange petite, pour spatule

Lampadina di ricambio piccola, per spatola



19-353-00-07,

19-353-01-07,

19-353-02-07,

19-353-03-07,

19-363-01-07,

19-383-00-07,

19-387-01-07



Etui für Laryngoskope (Warm- und Kaltlicht)

Case for Laryngoscopes (warm light and cold light)

Estuche para laringoscopios (luz cálida y fría)

Trousse pour laryngoscopes (lumière chaude et froide)

Scatola per laringoscopia (luce calda e fredda)

19-398-01-04

für drei gerade Laryngoskopspatel
for three straight laryngoscope blades
para tres hojas de laringoscopia rectas
pour trois spatules à laryngoscopie droites
per tre spatole per laringoscopia rette

19-398-03-04

für drei gebogene Laryngoskopspatel
for three curved laryngoscope blades
para tres hojas de laringoscopia curvas
pour trois spatules à laryngoscopie courbées
per tre spatole per laringoscopia curve

19-398-02-04

für vier gerade Laryngoskopspatel
for four straight laryngoscope blades
para cuatro hojas de laringoscopia rectas
pour quatre spatules à laryngoscopie droites
per quattro spatole per laringoscopia rette

19-398-04-04

für vier gebogene Laryngoskopspatel
for four curved laryngoscope blades
para cuatro hojas de laringoscopia curvas
pour quatre spatules à laryngoscopie courbées
per quattro spatole per laringoscopia curve

Kaltlicht-Laryngoskope und Zubehör

Fiber Optic Laryngoscopes and Accessories

Laringoscopios de luz fría y accesorios

Laryngoscopes de lumière froide et accessoires

Laringoscopi di luce fredda ed accessori



McIntosh
19-500-00-07 -
19-520-04-07

19-500-00-07

Set mit Batteriehandgriff 19-600-00-02 (ohne Batterien) und drei Laryngoskopspateln Fig. 1 bis 3, komplett, in Etui

Set with battery handle 19-600-00-02 (without batteries) and three laryngoscope blades fig. 1 to 3, complete, in case

Juego con mango de pilas 19-600-00-02 (sin pilas) y tres hojas de laringoscopio fig. 1 a 3, completo, en estuche

Set avec manche à pile 19-600-00-02 (sans pile) et trois spatules à laryngoscopie fig. 1 à 3, complet, en trousse

Set con manico a pila 19-600-00-02 (senza pila) e tre spatole per laringoscopia fig. 1 fino a 3, completo, in scatola

19-505-00-07

Set mit Induktiv-Akku-Handgriff 19-606-00-02 und drei Laryngoskopspateln Fig. 1 bis 3, komplett, in Etui

Set with inductive accumulator handle 19-606-00-02 and three laryngoscope blades fig. 1 to 3, complete, in case

Juego con mango acumulador por inducción 19-606-00-02 y tres hojas de laringoscopio fig. 1 a 3, completo, en estuche

Set avec manche à accumulateur à induction 19-606-00-02 et trois spatules à laryngoscopie fig. 1 à 3, complet, en trousse

Set con manico a accumulatore induttivo 19-606-00-02 e tre spatole per laringoscopia fig. 1 fino a 3, completo, in scatola

19-510-00-07

Set mit Batteriehandgriff 19-600-00-02 (ohne Batterien) und vier Laryngoskopspateln Fig. 1 bis 4, komplett, in Etui

Set with battery handle 19-600-00-02 (without batteries) and four laryngoscope blades fig. 1 to 4, complete, in case

Juego con mango de pilas 19-600-00-02 (sin pilas) y cuatro hojas de laringoscopio fig. 1 a 4, completo, en estuche

Set avec manche à pile 19-600-00-02 (sans pile) et quatre spatules à laryngoscopie fig. 1 à 4, complet, en trousse

Set con manico a pila 19-600-00-02 (senza pila) e quattro spatole per laringoscopia fig. 1 fino a 4, completo, in scatola

19-515-00-07

Set mit Induktiv-Akku-Handgriff 19-606-00-02 und vier Laryngoskopspateln Fig. 1 bis 4, komplett, in Etui

Set with inductive accumulator handle 19-606-00-02 and four laryngoscope blades fig. 1 to 4, complete, in case

Juego con mango acumulador por inducción 19-606-00-02 y cuatro hojas de laringoscopio fig. 1 a 4, completo, en estuche

Set avec manche à accumulateur à induction 19-606-00-02 et quatre spatules à laryngoscopie fig. 1 à 4, complet, en trousse

Set con manico a accumulatore induttivo 19-606-00-02 e quattro spatole per laringoscopia fig. 1 fino a 4, completo, in scatola



19-520-00-07

Fig. 0

für Säuglinge
for babies
para neonatales
pour nourrissons
per neonati

Nutzlänge
working length
largo útil
longueur utile
lunghezza operante
55 mm



19-520-01-07

Fig. 1

für Kinder
for children
para niños
pour enfants
per bambini

Nutzlänge
working length
largo útil
longueur utile
lunghezza operante
70 mm



19-520-02-07

Fig. 2

für Jugendliche
for adolescents
para adolescentes
pour adolescents
per adolescenti

Nutzlänge
working length
largo útil
longueur utile
lunghezza operante
85 mm



19-520-03-07

Fig. 3

für Frauen
for women
para mujeres
pour femmes
per donne

Nutzlänge
working length
largo útil
longueur utile
lunghezza operante
105 mm



19-520-04-07

Fig. 4

für Männer
for men
para hombres
pour hommes
per uomini

Nutzlänge
working length
largo útil
longueur utile
lunghezza operante
130 mm

1/2

Kaltlicht-Laryngoskope und Zubehör

Fiber Optic Laryngoscopes and Accessories

Laringoscopios de luz fría y accesorios

Laryngoscopes de lumière froide et accessoires

Laringoscopi di luce fredda ed accessori



Foregger

19-540-00-07 -
19-560-04-07

19-540-00-07

Set mit Batteriehandgriff 19-600-00-02 (ohne Batterien) und drei Laryngoskopspateln Fig. 2 bis 4, komplett, in Etui

Set with battery handle 19-600-00-02 (without batteries) and three laryngoscope blades fig. 2 to 4, complete, in case

Juego con mango de pilas 19-600-00-02 (sin pilas) y tres hojas de laringoscopio fig. 2 a 4, completo, en estuche

Set avec manche à pile 19-600-00-02 (sans pile) et trois spatules à laryngoscopie fig. 2 à 4, complet, en trousse

Set con manico a pila 19-600-00-02 (senza pila) e tre spatole per laringoscopia fig. 2 fino a 4, completo, in scatola

19-545-00-07

Set mit Induktiv-Akku-Handgriff 19-606-00-02 und drei Laryngoskopspateln Fig. 2 bis 4, komplett, in Etui

Set with inductive accumulator handle 19-606-00-02 and three laryngoscope blades fig. 2 to 4, complete, in case

Juego con mango acumulador por inducción 19-606-00-02 y tres hojas de laringoscopio fig. 2 a 4, completo, en estuche

Set avec manche à accumulateur à induction 19-606-00-02 et trois spatules à laryngoscopie fig. 2 à 4, complet, en trousse

Set con manico a accumulatore induttivo 19-606-00-02 e tre spatole per laringoscopia fig. 2 fino a 4, completo, in scatola

19-550-00-07

Set mit Batteriehandgriff 19-600-00-02 (ohne Batterien) und vier Laryngoskopspateln Fig. 1 bis 4, komplett, in Etui

Set with battery handle 19-600-00-02 (without batteries) and four laryngoscope blades fig. 1 to 4, complete, in case

Juego con mango de pilas 19-600-00-02 (sin pilas) y cuatro hojas de laringoscopio fig. 1 a 4, completo, en estuche

Set avec manche à pile 19-600-00-02 (sans pile) et quatre spatules à laryngoscopie fig. 1 à 4, complet, en trousse

Set con manico a pila 19-600-00-02 (senza pila) e quattro spatole per laringoscopia fig. 1 fino a 4, completo, in scatola

19-555-00-07

Set mit Induktiv-Akku-Handgriff 19-606-00-02 und vier Laryngoskopspateln Fig. 1 bis 4, komplett, in Etui

Set with inductive accumulator handle 19-606-00-02 and four laryngoscope blades fig. 1 to 4, complete, in case

Juego con mango acumulador por inducción 19-606-00-02 y cuatro hojas de laringoscopio fig. 1 a 4, completo, en estuche

Set avec manche à accumulateur à induction 19-606-00-02 et quatre spatules à laryngoscopie fig. 1 à 4, complet, en trousse

Set con manico a accumulatore induttivo 19-606-00-02 e quattro spatole per laringoscopia fig. 1 fino a 4, completo, in scatola



19-560-00-07

Fig. 0

für Säuglinge
for babies
para neonatales
pour nourrissons
per neonati

Nutzlänge
working length
largo útil
longueur utile
lunghezza operante
55 mm

19-560-01-07

Fig. 1

für Kinder
for children
para niños
pour enfants
per bambini

Nutzlänge
working length
largo útil
longueur utile
lunghezza operante
70 mm

19-560-02-07

Fig. 2

für Jugendliche
for adolescents
para adolescentes
pour adolescents
per adolescenti

Nutzlänge
working length
largo útil
longueur utile
lunghezza operante
90 mm

19-560-03-07

Fig. 3

für Frauen
for women
para mujeres
pour femmes
per donne

Nutzlänge
working length
largo útil
longueur utile
lunghezza operante
110 mm

19-560-04-07

Fig. 4

für Männer
for men
para hombres
pour hommes
per uomini

Nutzlänge
working length
largo útil
longueur utile
lunghezza operante
135 mm

1/2

Kaltlicht-Laryngoskope und Zubehör

Fiber Optic Laryngoscopes and Accessories

Laringoscopios de luz fría y accesorios

Laryngoscopes de lumière froide et accessoires

Laringoscopi di luce fredda ed accessori



Miller

19-565-00-07 -

19-585-04-07

19-565-00-07

Set mit Batteriehandgriff 19-600-00-02 (ohne Batterien) und drei Laryngoskopspateln Fig. 1 bis 3, komplett, in Etui

Set with battery handle 19-600-00-02 (without batteries) and three laryngoscope blades fig. 1 to 3, complete, in case

Juego con mango de pilas 19-600-00-02 (sin pilas) y tres hojas de laringoscopio fig. 1 a 3, completo, en estuche

Set avec manche à pile 19-600-00-02 (sans pile) et trois spatules à laryngoscopie fig. 1 à 3, complet, en trousse

Set con manico a pila 19-600-00-02 (senza pila) e tre spatole per laringoscopia fig. 1 fino a 3, completo, in scatola

19-570-00-07

Set mit Induktiv-Akku-Handgriff 19-606-00-02 und drei Laryngoskopspateln Fig. 1 bis 3, komplett, in Etui

Set with inductive accumulator handle 19-606-00-02 and three laryngoscope blades fig. 1 to 3, complete, in case

Juego con mango acumulador por inducción 19-606-00-02 y tres hojas de laringoscopio fig. 1 a 3, completo, en estuche

Set avec manche à accumulateur à induction 19-606-00-02 et trois spatules à laryngoscopie fig. 1 à 3, complet, en trousse

Set con manico a accumulatore induttivo 19-606-00-02 e tre spatole per laringoscopia fig. 1 fino a 3, completo, in scatola

19-575-00-07

Set mit Batteriehandgriff 19-600-00-02 (ohne Batterien) und vier Laryngoskopspateln Fig. 1 bis 4, komplett, in Etui

Set with battery handle 19-600-00-02 (without batteries) and four laryngoscope blades fig. 1 to 4, complete, in case

Juego con mango de pilas 19-600-00-02 (sin pilas) y cuatro hojas de laringoscopio fig. 1 a 4, completo, en estuche

Set avec manche à pile 19-600-00-02 (sans pile) et quatre spatules à laryngoscopie fig. 1 à 4, complet, en trousse

Set con manico a pila 19-600-00-02 (senza pila) e quattro spatole per laringoscopia fig. 1 fino a 4, completo, in scatola

19-580-00-07

Set mit Induktiv-Akku-Handgriff 19-606-00-02 und vier Laryngoskopspateln Fig. 1 bis 4, komplett, in Etui

Set with inductive accumulator handle 19-606-00-02 and four laryngoscope blades fig. 1 to 4, complete, in case

Juego con mango acumulador por inducción 19-606-00-02 y cuatro hojas de laringoscopio fig. 1 a 4, completo, en estuche

Set avec manche à accumulateur à induction 19-606-00-02 et quatre spatules à laryngoscopie fig. 1 à 4, complet, en trousse

Set con manico a accumulatore induttivo 19-606-00-02 e quattro spatole per laringoscopia fig. 1 fino a 4, completo, in scatola



J



19-585-00-07

Fig. 0

für Säuglinge
for babies
para neonatales
pour nourrissons
per neonati

Nutzlänge
working length
largo útil
longueur utile
lunghezza operante
55 mm



19-585-01-07

Fig. 1

für Kinder
for children
para niños
pour enfants
per bambini

Nutzlänge
working length
largo útil
longueur utile
lunghezza operante
80 mm



19-585-02-07

Fig. 2

für Jugendliche
for adolescents
para adolescentes
pour adolescents
per adolescenti

Nutzlänge
working length
largo útil
longueur utile
lunghezza operante
130 mm



19-585-03-07

Fig. 3

für Frauen
for women
para mujeres
pour femmes
per donne

Nutzlänge
working length
largo útil
longueur utile
lunghezza operante
170 mm



19-585-04-07

Fig. 4

für Männer
for men
para hombres
pour hommes
per uomini

Nutzlänge
working length
largo útil
longueur utile
lunghezza operante
189 mm

1/2

19

Kaltlicht-Laryngoskope und Zubehör

Fiber Optic Laryngoscopes and Accessories

Laringoscopios de luz fría y accesorios

Laryngoscopes de lumière froide et accessoires

Laringoscopi di luce fredda ed accessori



1/1

19-640-00-04

Ersatzlampe
Spare Bulb
Bombilla de recambio
Ampoule de rechange
Lampadina di ricambio
Krypton, 2,5 V



19-600-00-02,
19-604-00-04,
19-607-00-02,
19-611-00-04,
19-615-00-02,
19-625-00-04



19-645-00-04

Ersatzlampe
Spare Bulb
Bombilla de recambio
Ampoule de rechange
Lampadina di ricambio
Xenon, 2,5 V



19-600-00-02,
19-604-00-04,
19-607-00-02,
19-611-00-04,
19-615-00-02,
19-625-00-04



1/2

19-600-00-02

Handgriff mit Batteriecontainer 19-604-00-04 für zwei Batterien Typ C (ohne Batterien) für Kaltlichtspatel, mit Xenonlampe, 2,5 V

Handle with battery container 19-604-00-04 for two type C batteries (batteries not included) for cold light blade, with xenon lamp, 2,5 V

Mango con contenedor de pilas 19-604-00-04 para dos pilas tipo C (sin pilas) para espátula de luz fría, con lámpara de xenón, 2,5 V

Manche avec compartiment à piles 19-604-00-04 pour deux piles de type C (sans piles) pour spatule à lumière froide, avec lampe xénon, 2,5 V

Manico con contenitore batteria 19-604-00-04 per due batterie tipo C (senza batterie) per spatola a luce fredda, con lampadina allo xeno, 2,5 V



1/2

19-604-00-04

Batteriecontainer für zwei Batterien Typ C (ohne Batterien)

Battery container for two type C batteries (batteries not included)

Contenedor de pilas para dos pilas tipo C (sin pilas)

Compartiment à piles pour deux piles de type C (sans piles)

Manico con contenitore batteria per due batterie tipo C (senza batterie)

(ohne Lampe)
(without bulb)
(sin bombilla)
(sans ampoule)
(senza lampadina)



19-600-00-02



1/2

19-615-00-02

Handgriff mit Batteriecontainer 19-625-00-04 für zwei Batterien Typ AA (ohne Batterien) für Kaltlichtspatel, mit Xenonlampe, 2,5 V

Handle with battery container 19-625-00-04 for two type AA batteries (batteries not included) for cold light blade, with xenon lamp, 2,5 V

Mango con contenedor de pilas 19-625-00-04 para dos pilas tipo AA (sin pilas) para espátula de luz fría, con lámpara de xenón, 2,5 V

Manche avec compartiment à piles 19-625-00-04 pour deux piles de type AA (sans piles) pour spatule à lumière froide, avec lampe xénon, 2,5 V

Manico con contenitore batteria per due batterie tipo AA (senza batterie) per spatola a luce fredda, con lampadina allo xeno, 2,5 V



1/2

19-625-00-04

Batteriecontainer für zwei Batterien Typ AA (ohne Batterien)

Battery container for two type AA batteries (batteries not included)

Contenedor de pilas para dos pilas tipo AA (sin pilas)

Compartiment à piles pour deux piles de type AA (sans piles)

Manico con contenitore batteria per due batterie tipo AA (senza batterie)

(ohne Lampe)
(without bulb)
(sin bombilla)
(sans ampoule)
(senza lampadina)



19-615-00-02

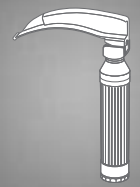

1/2

19-606-00-02

Handgriff mit Induktiv-Akkueinsatz 19-610-00-04 und High Power LED (> 50.000 Lux)

Handle with inductive accumulator insert 19-610-00-04 and high power LED (> 50,000 lux)

Mango con inserto de acumuladores recargables por inducción 19-610-00-04 y LED de alta potencia (> 50.000 Lux)

Manche avec insert d'accumulateur à induction 19-610-00-04 et High Power LED (> 50.000 lux)

Manico con inserto accumulatore induttivo 19-610-00-04 e LED High Power (> 50.000 Lux)



1/2

19-610-00-04

Induktiv-Akkueinsatz mit Lithium-Ionen-Akku und High Power LED (> 50.000 Lux)

Inductive accumulator insert with lithium-ion accumulator and high power LED (> 50,000 lux)

Inserto de acumuladores de iones de litio recargables por inducción y LED de alta potencia (> 50.000 Lux)

Insert d'accumulateur à induction avec batterie lithium-ion et High Power LED (> 50.000 lux)

Manico con inserto accumulatore induttivo agli ioni di litio e LED High Power (> 50.000 Lux)



19-606-00-02



1/2

19-607-00-02

Handgriff mit Induktiv-Akkueinsatz 19-611-00-04 und Xenonlampe, 2,5 V

Handle with inductive accumulator insert 19-611-00-04 and xenon lamp, 2.5 V

Mango con inserto de acumuladores recargables por inducción 19-611-00-04 y lámpara de xenón, 2,5 V

Manche avec insert d'accumulateur à induction 19-611-00-04 et lampe xénon, 2,5 V

Manico con inserto accumulatore induttivo 19-611-00-04 e lampadina allo xeno, 2,5 V



1/2

19-611-00-04

Induktiv-Akkueinsatz Inductive accumulator insert

Inserto de acumuladores recargables por inducción

Insert d'accumulateur à induction

Inserto accumulatore induttivo

(ohne Lampe)

(without bulb)

(sin bombilla)

(sans ampoule)

(senza lampadina)



19-607-00-02

Kaltlicht-Laryngoskope und Zubehör

Fiber Optic Laryngoscopes and Accessories

Laringoscopios de luz fría y accesorios

Laryngoscopes de lumière froide et accessoires

Laringoscopi di luce fredda ed accessori



1/2

19-620-00-04

Induktiv-Ladegerät mit integriertem Netzteil und Adapter für EU, UK, USA und Australien, 110-240 V, 50-60 Hz
Die Induktivakkus 19-610-00-04 und 19-611-00-04 können mit und ohne Handgriff geladen werden

Inductive charger with integrated power supply unit and adapter for EU, UK, USA, and Australia, 110-240 V, 50-60 Hz
Inductive batteries 19-610-00-04 and 19-611-00-04 can be charged with or without the handle

Cargador por inducción con fuente de alimentación integrada y adaptador para UE, GB, EE.UU. y Australia, 110-240 V, 50-60 H
Los acumuladores recargables por inducción 19-610-00-04 y 19-611-00-04 se pueden cargar con y sin mango

Chargeur à induction avec bloc d'alimentation intégré et adaptateur pour EU, UK, USA et Australie, 110-240 V, 50-60 H
Les accumulateurs à induction 19-610-00-04 et 19-611-00-04 peuvent être chargés avec et sans le manche

Caricatore induttivo con alimentatore integrato e adattatore per EU, UK, USA e Australia, 110-240 V, 50-60 H
Gli accumulatori induttivi 19-610-00-04 e 19-611-00-04 possono essere caricati con o senza manico

Naht
Suture
Sutura
Suture
Sutura

20

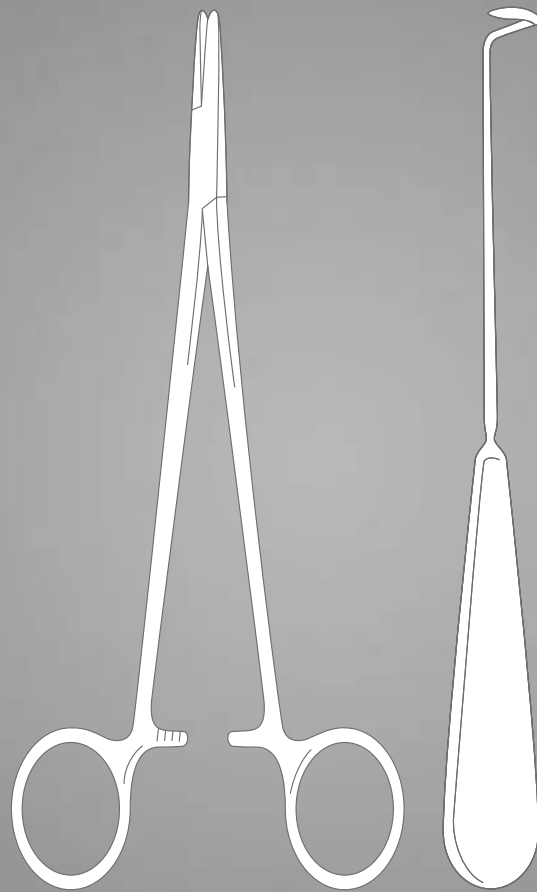

Chirurgische Nadeln

Surgical Needles

Agujas quirúrgicas

Aiguilles chirurgicales

Aghi chirurgici

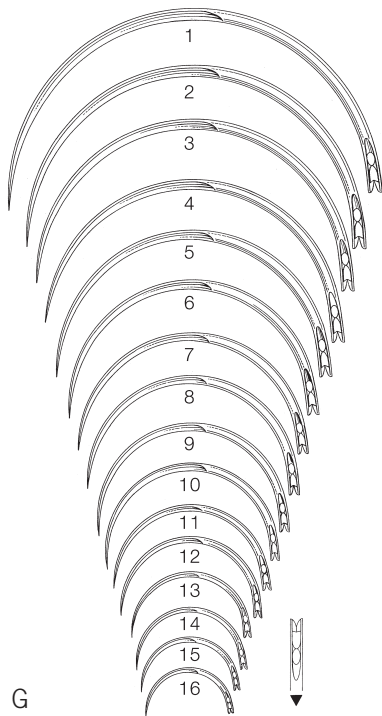

G

	Fig.
20-123-01-04	1
20-123-02-04	2
20-123-03-04	3
20-123-04-04	4
20-123-05-04	5
20-123-06-04	6
20-123-07-04	7
20-123-08-04	8
20-123-09-04	9
20-123-10-04	10
20-123-11-04	11
20-123-12-04	12
20-123-13-04	13
20-123-14-04	14
20-123-15-04	15
20-123-16-04	16

gebogen 1/2 Kreis, VE = 12 Stück
 curved, 1/2 circle, SU = 12/pack
 curvas 1/2 círculo, UV = 12 piezas
 courbes 1/2 cercle, UC = 12 untiés
 curvi 1/2 circolo, UV = 12 pezzi

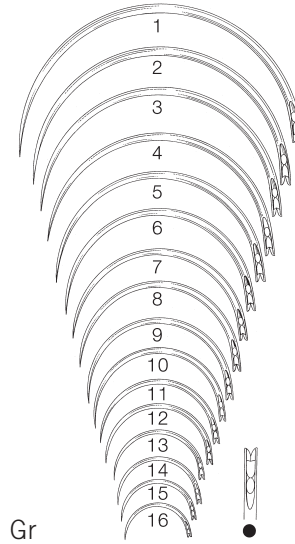

Gr

	Fig.
20-127-01-04	1
20-127-02-04	2
20-127-03-04	3
20-127-04-04	4
20-127-05-04	5
20-127-06-04	6
20-127-07-04	7
20-127-08-04	8
20-127-09-04	9
20-127-10-04	10
20-127-11-04	11
20-127-12-04	12
20-127-13-04	13
20-127-14-04	14
20-127-15-04	15
20-127-16-04	16

gebogen 1/2 Kreis, VE = 12 Stück
 curved, 1/2 circle, SU = 12/pack
 curvas 1/2 círculo, UV = 12 piezas
 courbes 1/2 cercle, UC = 12 untiés
 curvi 1/2 circolo, UV = 12 pezzi

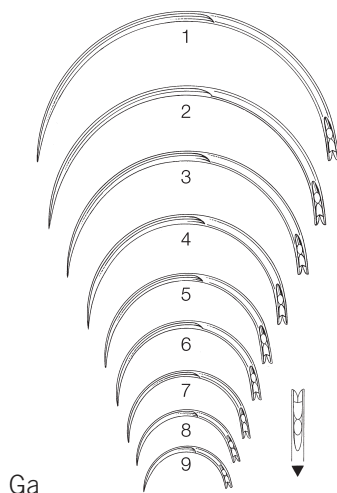

Ga

	Fig.
20-133-01-04	1
20-133-02-04	2
20-133-03-04	3
20-133-04-04	4
20-133-05-04	5
20-133-06-04	6
20-133-07-04	7
20-133-08-04	8
20-133-09-04	9

gebogen 1/2 Kreis, VE = 12 Stück
 curved, 1/2 circle, SU = 12/pack
 curvas 1/2 círculo, UV = 12 piezas
 courbes 1/2 cercle, UC = 12 untiés
 curvi 1/2 circolo, UV = 12 pezzi

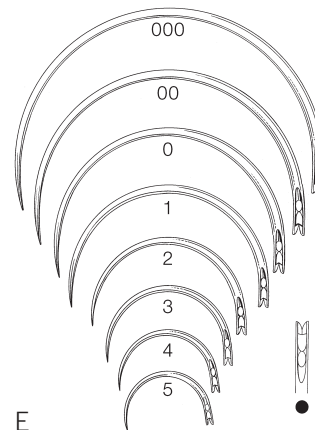

E

	Fig.
20-154-10-04	0
20-154-20-04	00
20-154-30-04	000
20-155-01-04	1
20-155-02-04	2
20-155-03-04	3
20-155-04-04	4
20-155-05-04	5

gebogen 1/2 Kreis, VE = 12 Stück
 curved, 1/2 circle, SU = 12/pack
 curvas 1/2 círculo, UV = 12 piezas
 courbes 1/2 cercle, UC = 12 untiés
 curvi 1/2 circolo, UV = 12 pezzi

Chirurgische Nadeln

Surgical Needles
 Agujas quirúrgicas
 Aiguilles chirurgicales
 Aghi chirurgici

Naht
 Suture
 Sutura
 Suture
 Sutura

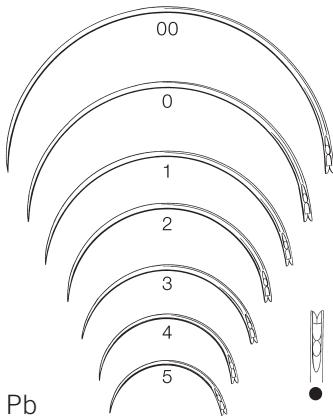
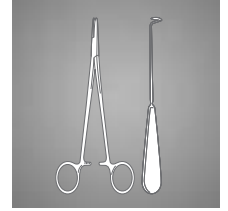

Pb

	Fig.
20-175-10-04	0
20-175-20-04	00
20-176-01-04	1
20-176-02-04	2
20-176-03-04	3
20-176-04-04	4
20-176-05-04	5

gebogen 1/2 Kreis, VE = 12 Stück
 curved, 1/2 circle, SU = 12/pack
 curvas 1/2 círculo, UV = 12 piezas
 courbes 1/2 cercle, UC = 12 untiés
 curvi 1/2 circolo, UV = 12 pezzi

20

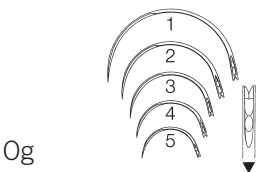

Og

	Fig.
20-209-01-04	1
20-209-02-04	2
20-209-03-04	3
20-209-04-04	4
20-209-05-04	5

Augennadel
 Eye Needle
 Aguja ocular
 Aiguilles ophtalmiques
 Ago oftalmico

gebogen 1/2 Kreis, VE = 12 Stück
 curved, 1/2 circle, SU = 12/pack
 curvas 1/2 círculo, UV = 12 piezas
 courbes 1/2 cercle, UC = 12 untiés
 curvi 1/2 circolo, UV = 12 pezzi

Mikro-Nadelhalter

Micro Needle Holders

Micro Porta-agujas

Micro porte-aiguilles

Micro Portaghi



		mit Sperre with ratchet con trinquete avec cran d'arrêt con arresto	mit Sperre with ratchet con trinquete avec cran d'arrêt con arresto	ohne Sperre w/o ratchet sin trinquete sans cran d'arrêt senza arresto	ohne Sperre w/o ratchet sin trinquete sans cran d'arrêt senza arresto
	Ø	0.30 mm	0.30 mm	0.30 mm	0.30 mm
15 cm / 5 7/8"	st	20-000-01-07	20-001-01-07	20-000-00-07	20-001-00-07

1/2

20-000-00-07 -
20-001-01-07



		mit Sperre with ratchet con trinquete avec cran d'arrêt con arresto	mit Sperre with ratchet con trinquete avec cran d'arrêt con arresto	ohne Sperre w/o ratchet sin trinquete sans cran d'arrêt senza arresto	ohne Sperre w/o ratchet sin trinquete sans cran d'arrêt senza arresto
	Ø	0.30 mm	0.30 mm	0.30 mm	0.30 mm
15 cm / 5 7/8"	st	20-000-03-07	20-001-03-07	20-000-02-07	20-001-02-07

1/2

Castroviejo
20-000-02-07 -
20-001-03-07

Mikro-Nadelhalter

Micro Needle Holders

Micro Porta-agujas

Micro porte-aiguilles

Micro Portaghi

Naht

Sutura

Sutura

Sutura

Sutura

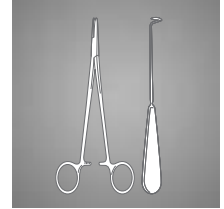

8-0 – 12-0

1/1



		mit Sperre with ratchet con trinquete avec cran d'arrêt con arresto	mit Sperre with ratchet con trinquete avec cran d'arrêt con arresto	ohne Sperre w/o ratchet sin trinquete sans cran d'arrêt senza arresto	ohne Sperre w/o ratchet sin trinquete sans cran d'arrêt senza arresto
	Ø	0.40 mm	0.40 mm	0.40 mm	0.40 mm
15 cm / 5 7/8"	St	20-002-15-07	20-003-15-07	20-004-15-07	20-005-15-07
	Ti	20-016-15-09	20-017-15-09	20-018-15-09	20-019-15-09
18 cm / 7 1/8"	St	20-002-18-07	20-003-18-07	20-004-18-07	20-005-18-07
	Ti	20-016-18-09	20-017-18-09	20-018-18-09	20-019-18-09

1/2

20-002-15-07 -
20-019-18-09



8-0 – 12-0

1/1



		mit Sperre with ratchet con trinquete avec cran d'arrêt con arresto	mit Sperre with ratchet con trinquete avec cran d'arrêt con arresto	ohne Sperre w/o ratchet sin trinquete sans cran d'arrêt senza arresto	ohne Sperre w/o ratchet sin trinquete sans cran d'arrêt senza arresto
	Ø	0.40 mm	0.40 mm	0.40 mm	0.40 mm
18 cm / 7 1/8"	St	20-006-18-07	20-007-18-07	20-008-18-07	20-009-18-07
	Ti	20-006-18-09	20-007-18-09	20-008-18-09	20-009-18-09

1/2

20-006-18-07 -
20-009-18-09

Mikro-Nadelhalter

Micro Needle Holders

Micro Porta-agujas

Micro porte-aiguilles

Micro Portaghi



6-0 - 10-0

1/1



1/2

20-010-15-07 -
20-023-25-09

		mit Sperre with ratchet con trinquete avec cran d'arrêt con arresto	mit Sperre with ratchet con trinquete avec cran d'arrêt con arresto	ohne Sperre w/o ratchet sin trinquete sans cran d'arrêt senza arresto	ohne Sperre w/o ratchet sin trinquete sans cran d'arrêt senza arresto
	Ø	0.80 mm	0.80 mm	0.80 mm	0.80 mm
15 cm / 5 7/8"	St	20-010-15-07	20-011-15-07	20-012-15-07	20-013-15-07
	Ti	20-020-15-09	20-021-15-09	20-022-15-09	20-023-15-09
18 cm / 7 1/8"	St	20-010-18-07	20-011-18-07	20-012-18-07	20-013-18-07
	Ti	20-020-18-09	20-021-18-09	20-022-18-09	20-023-18-09
21 cm / 8 3/8"	St	20-010-21-07	20-011-21-07	20-012-21-07	20-013-21-07
	Ti	20-020-21-09	20-021-21-09	20-022-21-09	20-023-21-09
23 cm / 9"	St	20-010-23-07	20-011-23-07	20-012-23-07	20-013-23-07
	Ti	20-020-23-09	20-021-23-09	20-022-23-09	20-023-23-09
25 cm / 9 7/8"	St	20-010-25-07	20-011-25-07	20-012-25-07	20-013-25-07
	Ti	20-020-25-09	20-021-25-09	20-022-25-09	20-023-25-09



5-0 - 8-0

1/1



1/2

20-030-15-07 -
20-033-25-09

		mit Sperre with ratchet con trinquete avec cran d'arrêt con arresto	mit Sperre with ratchet con trinquete avec cran d'arrêt con arresto	ohne Sperre w/o ratchet sin trinquete sans cran d'arrêt senza arresto	ohne Sperre w/o ratchet sin trinquete sans cran d'arrêt senza arresto
	Ø	1.2 mm	1.2 mm	1.2 mm	1.2 mm
15 cm / 5 7/8"	St	20-030-15-07	20-031-15-07	20-032-15-07	20-033-15-07
	Ti	20-030-15-09	20-031-15-09	20-032-15-09	20-033-15-09
18 cm / 7 1/8"	St	20-030-18-07	20-031-18-07	20-032-18-07	20-033-18-07
	Ti	20-030-18-09	20-031-18-09	20-032-18-09	20-033-18-09
21 cm / 8 3/8"	St	20-030-21-07	20-031-21-07	20-032-21-07	20-033-21-07
	Ti	20-030-21-09	20-031-21-09	20-032-21-09	20-033-21-09
23 cm / 9"	St	20-030-23-07	20-031-23-07	20-032-23-07	20-033-23-07
	Ti	20-030-23-09	20-031-23-09	20-032-23-09	20-033-23-09
25 cm / 9 7/8"	St	20-030-25-07	20-031-25-07	20-032-25-07	20-033-25-07
	Ti	20-030-25-09	20-031-25-09	20-032-25-09	20-033-25-09

Mikro-Nadelhalter

Micro Needle Holders

Micro Porta-agujas

Micro porte-aiguilles

Micro Portaghi

Naht

Suture

Sutura

Suture

Sutura



1/2



6-0 - 10-0

1/1



		mit Sperre with ratchet con trinquete avec cran d'arrêt con arresto	mit Sperre with ratchet con trinquete avec cran d'arrêt con arresto	ohne Sperre w/o ratchet sin trinquete sans cran d'arrêt senza arresto	ohne Sperre w/o ratchet sin trinquete sans cran d'arrêt senza arresto
	Ø	0.80 mm	0.80 mm	0.80 mm	0.80 mm
15 cm / 5 7/8"	St	20-060-15-07	20-061-15-07	20-062-15-07	20-063-15-07
	Ti	20-060-15-09	20-061-15-09	20-062-15-09	20-063-15-09
18 cm / 7 1/8"	St	20-060-18-07	20-061-18-07	20-062-18-07	20-063-18-07
	Ti	20-060-18-09	20-061-18-09	20-062-18-09	20-063-18-09
21 cm / 8 3/8"	St	20-060-21-07	20-061-21-07	20-062-21-07	20-063-21-07
	Ti	20-060-21-09	20-061-21-09	20-062-21-09	20-063-21-09
23 cm / 9"	St	20-060-23-07	20-061-23-07	20-062-23-07	20-063-23-07
	Ti	20-060-23-09	20-061-23-09	20-062-23-09	20-063-23-09

20-060-15-07 -
20-063-23-09



1/2



5-0 - 8-0

1/1



		mit Sperre with ratchet con trinquete avec cran d'arrêt con arresto	mit Sperre with ratchet con trinquete avec cran d'arrêt con arresto	ohne Sperre w/o ratchet sin trinquete sans cran d'arrêt senza arresto	ohne Sperre w/o ratchet sin trinquete sans cran d'arrêt senza arresto
	Ø	1.2 mm	1.2 mm	1.2 mm	1.2 mm
15 cm / 5 7/8"	St	20-070-15-07	20-071-15-07	20-072-15-07	20-073-15-07
	Ti	20-070-15-09	20-071-15-09	20-072-15-09	20-073-15-09
18 cm / 7 1/8"	St	20-070-18-07	20-071-18-07	20-072-18-07	20-073-18-07
	Ti	20-070-18-09	20-071-18-09	20-072-18-09	20-073-18-09
21 cm / 8 3/8"	St	20-070-21-07	20-071-21-07	20-072-21-07	20-073-21-07
	Ti	20-070-21-09	20-071-21-09	20-072-21-09	20-073-21-09
23 cm / 9"	St	20-070-23-07	20-071-23-07	20-072-23-07	20-073-23-07
	Ti	20-070-23-09	20-071-23-09	20-072-23-09	20-073-23-09

20-070-15-07 -
20-073-23-09

Mikro-Nadelhalter

Micro Needle Holders

Micro Porta-agujas

Micro porte-aiguilles

Micro Portaghi



1/2
Kalt
20-274-14-07
13,5 cm / 5 1/8"





1/2
Barraquer-Troutman
20-288-10-07 -
20-289-10-07

1/4  
20-288-10-07 20-289-10-07
10,5 cm / 4 1/8" 10,5 cm / 4 1/8"







1/2
Arruga
20-290-14-07 -
20-291-14-07

1/4  
20-290-14-07 20-291-14-07
13,5 cm / 5 3/8" 13,5 cm / 5 3/8"



1/2
Barraquer-Troutman
20-298-10-07 -
20-299-11-07

1/4  
20-298-10-07 20-298-11-07
10,5 cm / 4 1/8" 11,5 cm / 4 4/8"
 
20-299-10-07 20-299-11-07
10,5 cm / 4 1/8" 11,5 cm / 4 4/8"

Mikro-Nadelhalter

Micro Needle Holders

Micro Porta-agujas

Micro porte-aiguilles

Micro Portaghi

Naht

Suture

Sutura

Suture

Sutura



1/2

1/1



		ohne Sperre w/o ratchet sin trinquete sans cran d'arrêt senza arresto	ohne Sperre w/o ratchet sin trinquete sans cran d'arrêt senza arresto	mit Sperre with ratchet con trinquete avec cran d'arrêt con arresto	ohne Sperre w/o ratchet sin trinquete sans cran d'arrêt senza arresto
11,5 cm / 4 1/8"	St	20-300-11-07	–	–	–
11,5 cm / 4 1/8"	Ti	20-300-12-09	–	–	–
13,5 cm / 5 3/8"	St	–	20-300-13-07	–	–
13,5 cm / 5 3/8"	St	–	–	20-300-14-07	–
14 cm / 5 1/8"	Ti	–	–	–	20-300-15-09

Barraquer
20-300-11-07 -
20-300-15-09



1/2

Barraquer
20-301-13-07
13,5 cm / 5 3/8"
sehr feines Maul
very delicate jaw
boca muy delicada
mors très fin
morso strafino



1/2

Castroviejo-Fino
20-302-01-07
13 cm / 5 1/8"
sehr feines Maul
very delicate jaw
boca muy delicada
mors très fin
morso strafino



1/2

Castroviejo-Fino
20-303-01-07
13 cm / 5 1/8"
sehr feines Maul
very delicate jaw
boca muy delicada
mors très fin
morso strafino



1/2

Castroviejo-Fino
20-304-01-07
13 cm / 5 1/8"
sehr feines Maul, mit Sperre
very delicate jaw, with lock
boca muy delicada, con cierre
mors très fin, avec serrure
morso strafino, con fermo



1/2

Castroviejo-Fino
20-305-01-07
13 cm / 5 1/8"
sehr feines Maul, mit Sperre
very delicate jaw, with lock
boca muy delicada, con cierre
mors très fin, avec serrure
morso strafino, con fermo

Mikro-Nadelhalter

Micro Needle Holders

Micro Porta-agujas

Micro porte-aiguilles

Micro Portaghi



Castroviejo-Fino
20-303-09-07
9 cm / 3 4/8"



Castroviejo-Fino
20-304-09-07
9 cm / 3 4/8"



Castroviejo-Fino
20-305-09-07
9 cm / 3 4/8"



Castroviejo
20-306-14-07 -
20-307-14-07

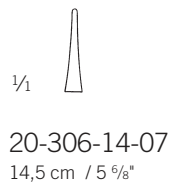

Castroviejo
20-308-14-07 -
20-309-14-07



Mikro-Nadelhalter, Nadelhalter

Micro Needle Holders, Needle Holders

Micro Porta-agujas, Porta-agujas

Micro porte-aiguilles, Porte-aiguilles

Micro Portaghi, Portaghi

Naht

Suture

Sutura

Suture

Sutura

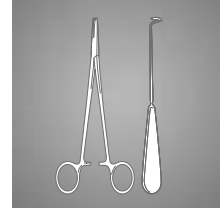

1/1



20-310-14-07
14,5 cm / 5 5/8"

20-311-14-07
14,5 cm / 5 5/8"



1/1



1/2

Castroviejo
20-310-14-07 -
20-311-14-07

Castroviejo
20-313-14-07
14,5 cm / 5 5/8"

20



1/1



20-314-16-07
16 cm / 6 2/8"

20-315-16-07
16 cm / 6 2/8"

1/2

Arruga
20-314-16-07 -
20-315-16-07



1/1



20-316-13-07

1/2

Castroviejo
20-316-13-07
12 cm / 4 6/8"



1/1



20-317-12-07

1/2

Castroviejo
20-317-12-07
12 cm / 4 6/8"

Nadelhalter

Needle Holders

Porta-agujas

Porte-aiguilles

Portaghi



1/1

20-326-12-07

12 cm / 4 5/8"

ein Maulteil gefenstert
one fenestrated jaw
un lado de la boca fenestrada
un côté de mors fenêtré
una parte del morso finestrato



20-328-12-07

13 cm / 5 1/8"

längsgerieftes Maul
jaw with longitudinal serration
boca con estrías longitudinales
mors avec rainures longitudinales
morso con strie longitudinali



1/1

Collier

20-332-12-07

12,5 cm / 4 7/8"

beide Maulteile durchgehend gefenstert
both jaws totally fenestrated
ambas mordazas completamente fenestradas
les deux mors fenêtrés sur toute leur longueur
entrambe le gole completamente a finestra

1/2

Derf

20-326-12-07 -
20-328-12-07



1/1

Webster

20-334-13-07

13 cm / 5 1/8"

glattes Maul
smooth jaw
boca lisa
mors lisse
morso liscio



1/1

Halsey

20-336-13-07

13,5 cm / 5 3/8"

glattes Maul
smooth jaw
boca lisa
mors lisse
morso liscio

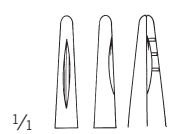

1/1



1/2

Neivert

20-338-13-07

12,5 cm / 4 7/8"

glattes Maul mit Spezialkehlung
smooth jaw, special groove
boca lisa, especialmente acanalada
mors lisse, avec stries spéciales
morso liscio con scannellatura speciale

Nadelhalter

Needle Holders
Porta-agujas
Porte-aiguilles
Portaghi

Naht

Suture
Sutura
Suture
Sutura

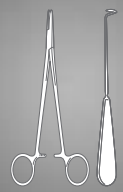

Hegar-Baumgartner
20-340-14-07
14,5 cm / 5 7/8"



20-344-13-07 20-344-18-07
13 cm / 5 1/8" 18 cm / 7 1/8"
Maul diagonal gerieft
diagonally serrated jaw
boca estriada transversalmente
mors strié transversalement
con strie diagonali

Brown
20-344-13-07 -
20-344-18-07
kräftiges Modell
heavy pattern
modelo fuerte
modèle fort
modello forte



Crile-Murray
20-348-15-07
15 cm / 5 7/8"
schlankes Modell
slender pattern
modelo delgado
modèle gracile
modello delicato



Crile-Wood
20-350-15-07
15 cm / 5 7/8"



Adson
20-360-18-07
18,5 cm / 7 3/8"
beide Maulteile durchgehend gefenestert
both jaws fenestrated throughout
ambas mordazas completamente fenestradas
les deux mors fenêtrés sur toute leur longueur
entrambe le gole completamente a finestra



Metzenbaum
20-364-18-07
18,5 cm / 7 3/8"
ein Maulteil gekehlt und gefenestert
one grooved and fenestrated jaw
un lado de la boca acanalado y fenestrado
un côté de mors strié et fenêtré
una parte del morso scannellata e finestrata

Nadelhalter

Needle Holders

Porta-agujas

Porte-aiguilles

Portaghi



M. G. Hospital
20-384-17-07
18 cm / 7 1/8"

kräftiges Modell
heavy pattern
modelo fuerte
modèle fort
modello forte



Mayo-Hegar
20-390-14-07 -
20-390-30-07

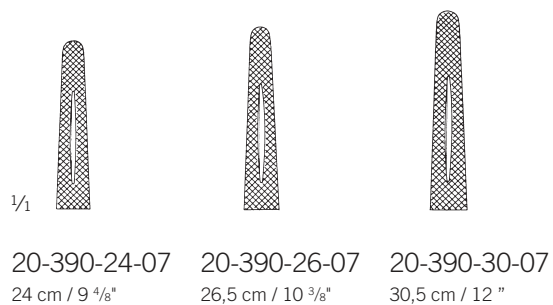
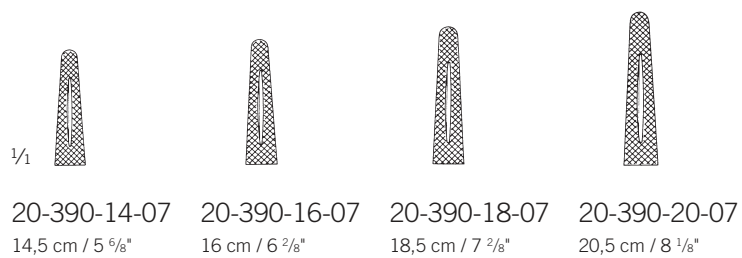

Mayo-Hegar
20-396-16-07 -
20-396-20-07

schlankes Modell
slender pattern
modelo delgado
modèle gracile
modello delicato

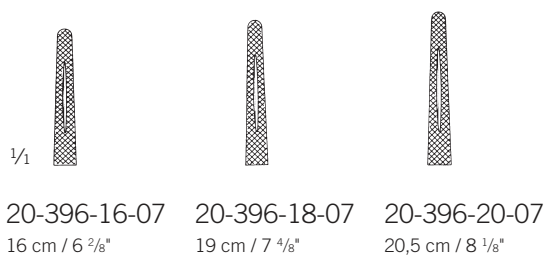

Heaney
20-403-21-07
20,5 cm / 8 1/8"

Nadelhalter

Needle Holders

Porta-agujas

Porte-aiguilles

Portaghi

Naht

Suture

Sutura

Suture

Sutura

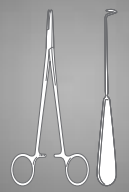

1/2

Jameson
20-404-23-07
23 cm / 9"



1/2

Masson
20-408-27-07
26,5 cm / 10 3/8"
kräftiges Modell
heavy pattern
modelo fuerte
modèle fort
modello forte



1/2

Finochietto
20-415-27-07
26,5 cm / 10 3/8"

Nadelhalter

Needle Holders

Porta-agujas

Porte-aiguilles

Portaghi



Wangensteen
20-420-27-07
26,5 cm / 10 ³/₈"



Johnson
20-437-27-07
27 cm / 10 ⁵/₈"

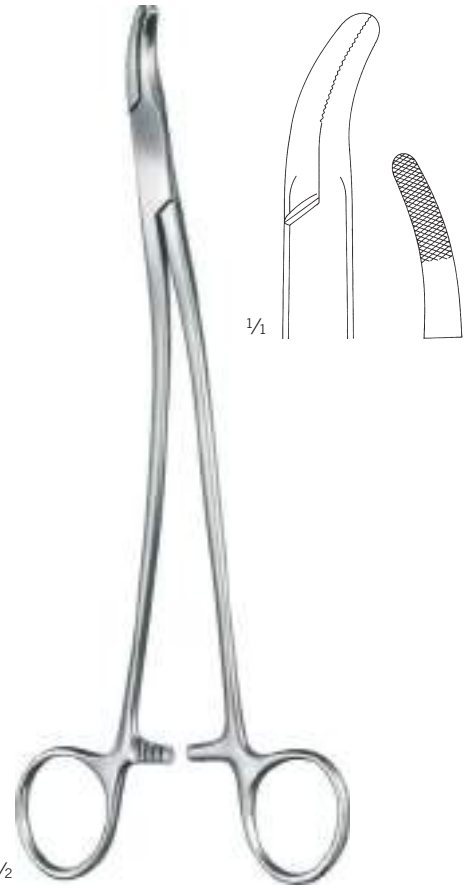

Stratte
20-451-23-07
23 cm / 9 "

Nadelhalter

Needle Holders
 Porta-agujas
 Porte-aiguilles
 Portaghi

Naht

Suture
 Sutura
 Sutura
 Sutura

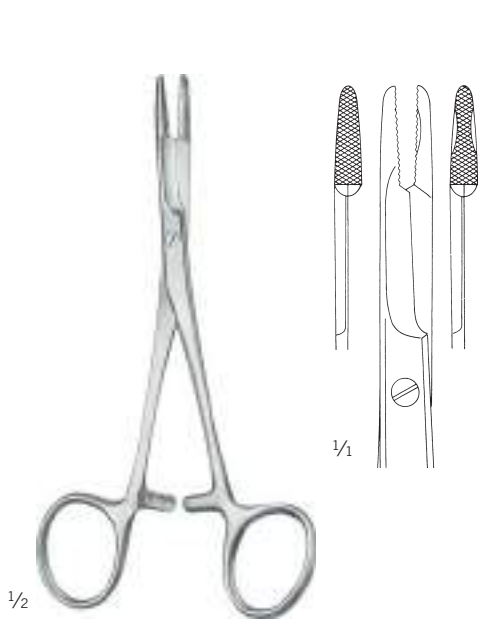
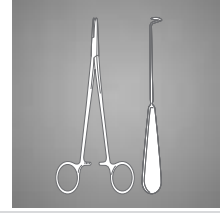

Olsen-Hegar
 20-466-14-07
 14 cm / 5 4/8"



Gillies
 20-469-16-07
 16 cm / 6 2/8"



Crile
 20-500-15-07
 15 cm / 5 7/8"

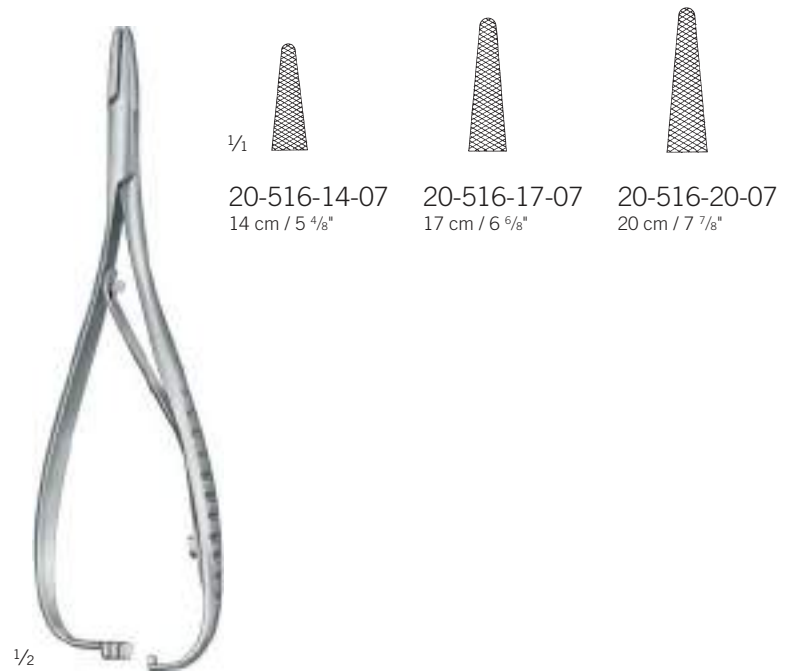

Mathieu
 20-516-14-07 -
 20-516-20-07

Mikro-Nadelhalter, Nadelhalter

Micro Needle Holders, Needle Holders

Micro Porta-agujas, Porta-agujas

Micro porte-aiguilles, Porte-aiguilles

Micro Portaghi, Portaghi

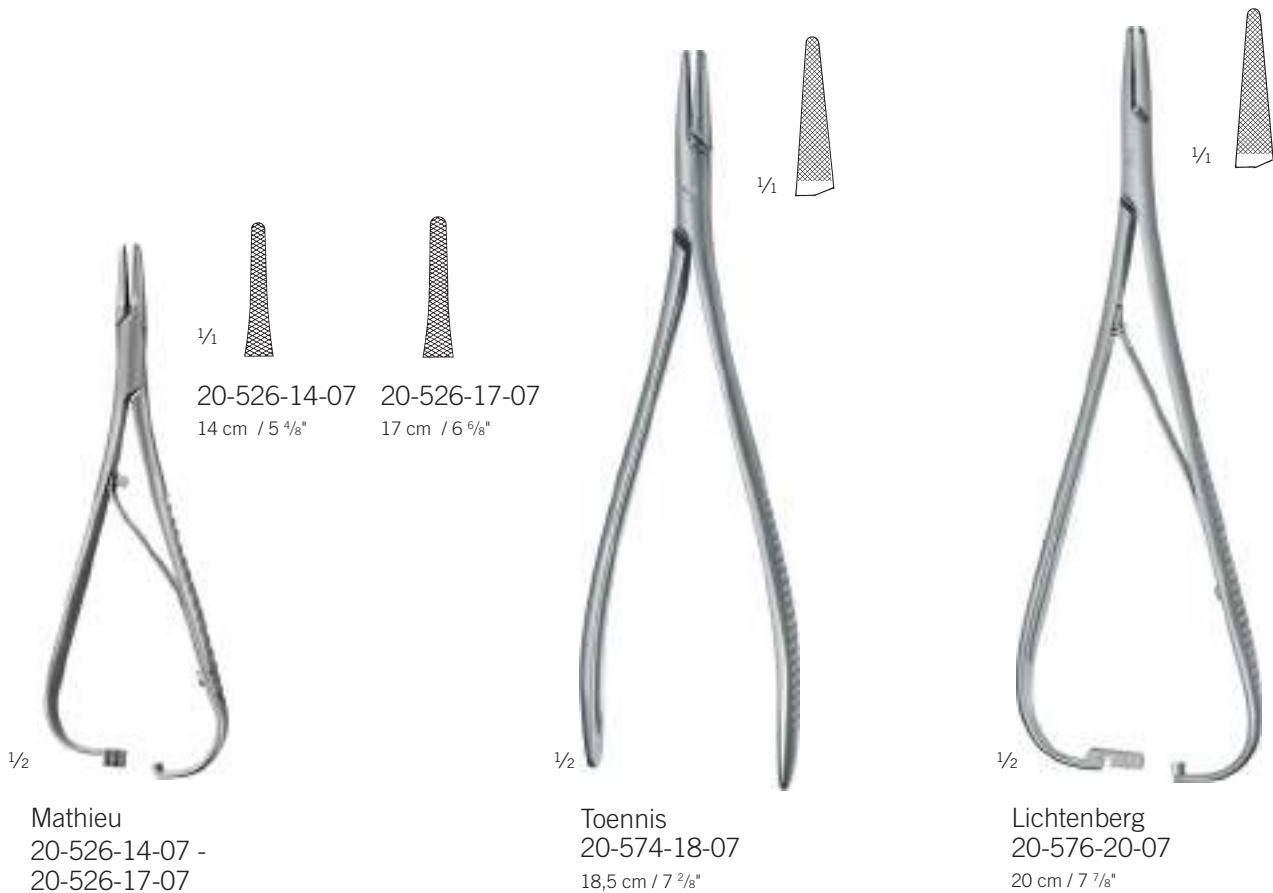

Mathieu

20-526-14-07 -
20-526-17-07

schlankes Modell
slender pattern
modelo delgado
modèle gracile
modello delicato

Toennis

20-574-18-07

18,5 cm / 7 2/8"

Lichtenberg

20-576-20-07

20 cm / 7 7/8"

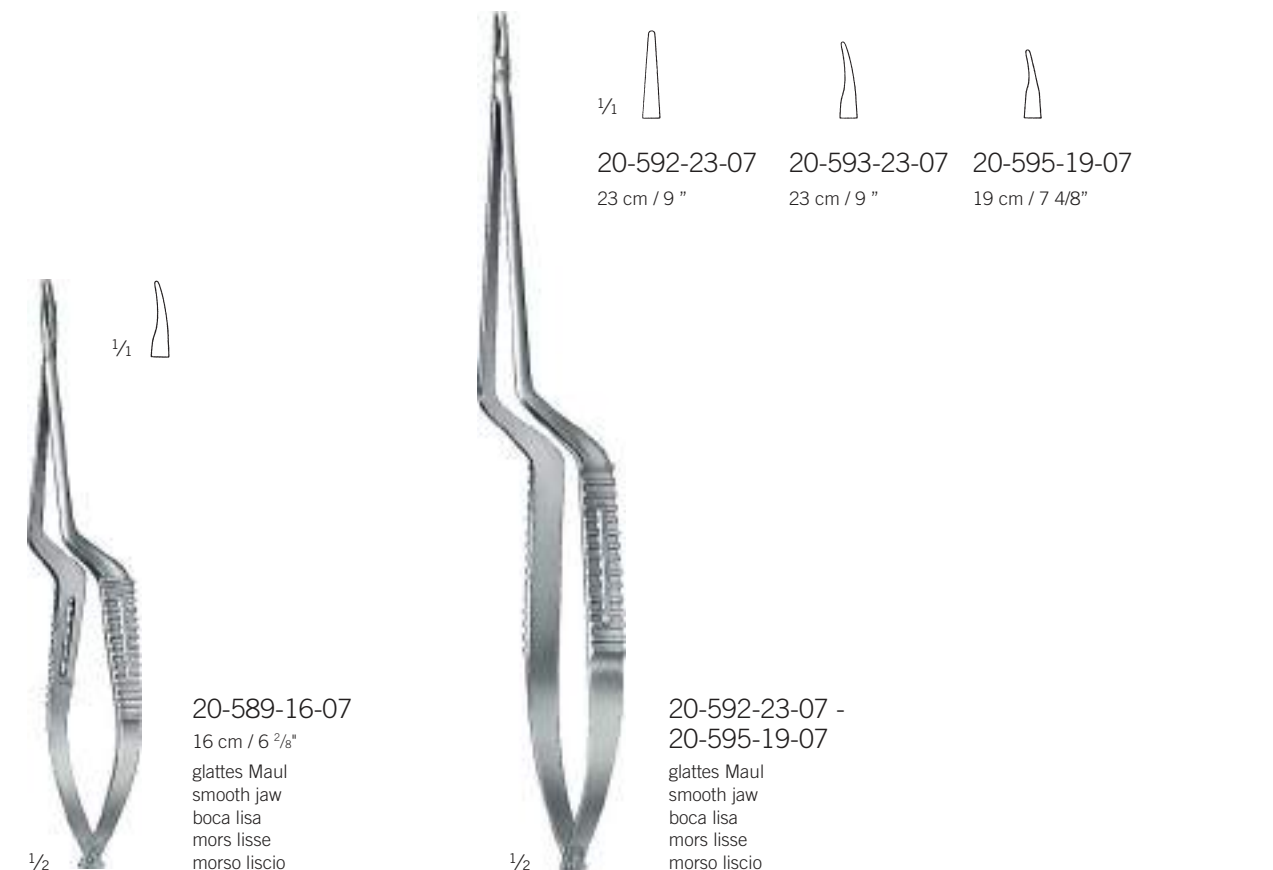

20-589-16-07

16 cm / 6 2/8"

glattes Maul
smooth jaw
boca lisa
mors lisse
morso liscio

20-592-23-07 -

20-595-19-07

glattes Maul
smooth jaw
boca lisa
mors lisse
morso liscio

Mikro-Nadelhalter, Nadelhalter

Micro Needle Holders, Needle Holders

Micro Porta-agujas, Porta-agujas

Micro porte-aiguilles, Porte-aiguilles

Micro Portaghi, Portaghi

Naht

Suture

Sutura

Suture

Sutura

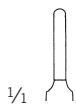

TC GOLD

6-0 - 12-0

Smooth

1/2

Hepp-Scheidel
20-602-18-07

18,5 cm / 7 2/8"



1/1

Webster
20-604-13-07

13 cm / 5 1/8"



Crile-Wood
20-604-15-07

15 cm / 5 7/8"

4-0 - 6-0

Mini

1/2

20-604-13-07 -
20-604-15-07

mit Durchdrücksperrung auch für Linkshänder geeignet
with automatic release ratchet also for lefthanders
con cremallera automática también para zurdos
avec crémaillère automatique aussi pour gauchers
con cremagliera automatica anche per mancini



safety-wave



diamond-coated

4-0 - 6-0

1/1

		mit Sperre with ratchet con trinquete avec cran d'arrêt con arresto	mit Sperre with ratchet con trinquete avec cran d'arrêt con arresto	ohne Sperre w/o ratchet sin trinquete sans cran d'arrêt senza arresto	ohne Sperre w/o ratchet sin trinquete sans cran d'arrêt senza arresto
	Ø	2.0 mm	2.0 mm	2.0 mm	2.0 mm
15 cm / 5 7/8"	St	20-606-15-07	20-605-15-07	20-608-15-07	20-607-15-07
18 cm / 7 1/8"	St	20-606-18-07	20-605-18-07	20-608-18-07	20-607-18-07
21 cm / 8 2/8"	St	20-606-21-07	20-605-21-07	20-608-21-07	20-607-21-07
23 cm / 9"	St	20-606-23-07	20-605-23-07	20-608-23-07	20-607-23-07
25 cm / 9 7/8"	St	20-606-25-07	20-605-25-07	20-608-25-07	20-607-25-07

1/2

20-605-15-07 -
20-608-25-07



1/1

5-0 - 8-0

Micro

1/2

Jaboma
20-610-18-07

18 cm / 7 1/8"

20

Mikro-Nadelhalter

Micro Needle Holders

Micro Porta-agujas

Micro porte-aiguilles

Micro Portaghi



4-0 - 6-0



diamond-coated



1/2

1/1

20-612-18-07

18 cm / 7 2/8"

20-612-21-07

21 cm / 7 2/8"

Gregory
20-612-18-07 -
20-612-21-07
doppelt übersetzt
double-action



2-0 - 6-0



diamond-coated



safety-wave



1/2

1/1



20-613-19-07

19 cm / 7 4/8"



20-613-23-07

23 cm / 9"



20-613-25-07

25 cm / 9 7/8"

Heavy Duty
20-613-19-07 -
20-613-25-07

Mikro-Nadelhalter

Micro Needle Holders

Micro Porta-agujas

Micro porte-aiguilles

Micro Portaghi

Naht

Suture

Sutura

Suture

Sutura

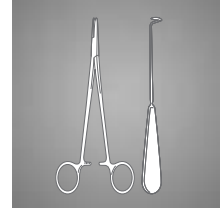

1/2



8-0 – 12-0

1/1



	●	mit Sperre with ratchet con trinquete avec cran d'arrêt con arresto	mit Sperre with ratchet con trinquete avec cran d'arrêt con arresto	ohne Sperre w/o ratchet sin trinquete sans cran d'arrêt senza arresto	ohne Sperre w/o ratchet sin trinquete sans cran d'arrêt senza arresto
∅		0.40 mm	0.40 mm	0.40 mm	0.40 mm
St		20-614-02-07	20-615-01-07	20-614-01-07	20-615-02-07

20-614-01-07 -
20-615-02-07
14,5 cm / 5 7/8"

20



1/2



8-0 – 12-0

1/1



	●	mit Sperre with ratchet con trinquete avec cran d'arrêt con arresto	mit Sperre with ratchet con trinquete avec cran d'arrêt con arresto	ohne Sperre w/o ratchet sin trinquete sans cran d'arrêt senza arresto	ohne Sperre w/o ratchet sin trinquete sans cran d'arrêt senza arresto
∅		0.40 mm	0.40 mm	0.40 mm	0.40 mm
St		20-614-03-07	20-615-04-07	20-614-03-07	20-615-03-07

20-614-03-07 -
20-615-04-07
14,5 cm / 5 7/8"

Mikro-Nadelhalter

Micro Needle Holders

Micro Porta-agujas

Micro porte-aiguilles

Micro Portaghi

TC GOLD



1/2

Castroviejo
20-620-00-07 -
20-621-21-07

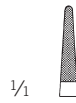

1/4

20-620-00-07

14,5 cm / 5 7/8"



20-620-01-07

14,5 cm / 5 7/8"

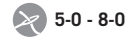

20-620-14-07

14,5 cm / 5 7/8"

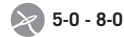

20-620-18-07

18 cm / 7 1/8"



1/4

20-620-21-07

22 cm / 8 5/8"

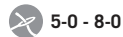

20-621-14-07

14,5 cm / 5 7/8"



20-621-18-07

18 cm / 7 1/8"



20-621-21-07

22 cm / 8 5/8"



1/2

Arruga
20-622-16-07 -
20-623-16-07
16 cm / 6 3/8"



1/4

20-622-16-07



20-623-16-07



Mikro-Nadelhalter

Micro Needle Holders

Micro Porta-agujas

Micro porte-aiguilles

Micro Portaghi

Naht

Suture

Sutura

Suture

Sutura

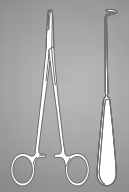

TC GOLD



1/1

6-0 - 12-0

Smooth

Castroviejo
20-624-13-07

12,5 cm / 4 7/8"

mit Sperre
with lock
con cierre
avec serrure
con fermo



1/1

6-0 - 12-0

Smooth

Barraquer
20-626-13-07

13 cm / 5 1/8"

mit Sperre
with lock
con cierre
avec serrure
con fermo



1/1

6-0 - 12-0

Smooth

Barraquer
20-628-13-07

13 cm / 5 1/8"

ohne Sperre
w/o ratchet
sin trinquete
sans cran d'arrêt
senza arresto

20



1/1

6-0 - 12-0

Smooth

Webster
20-630-13-07

13 cm / 5 1/8"



1/1

4-0 - 6-0

Mini

Kilner
20-631-13-07

14,5 cm / 5 6/8"

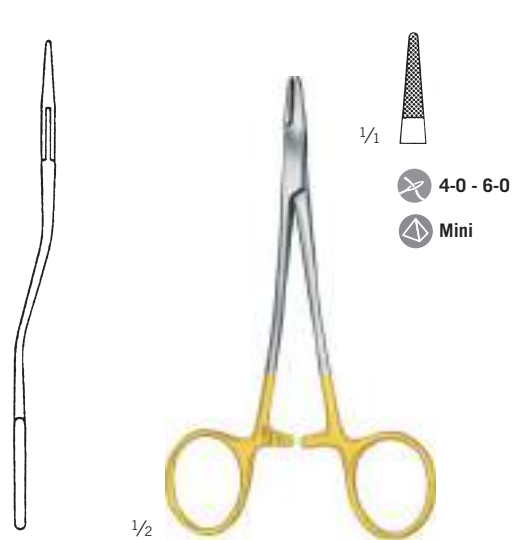

1/1

4-0 - 6-0

Mini

Derf
20-632-12-07

12 cm / 4 6/8"

Nadelhalter

Needle Holders

Porta-agujas

Porte-aiguilles

Portaghi

TC GOLD



1/1

20-634-13-07

13 cm / 5 1/8"

4-0 - 6-0

Mini

1/2

Hegar-Baumgartner
20-634-13-07 -
20-634-14-07



20-634-14-07

14,5 cm / 5 6/8"

4-0 - 6-0

Mini

1/2

Halsey
20-636-13-07 -
20-637-13-07



1/1

20-636-13-07

13 cm / 5 1/8"

6-0 - 12-0

Smooth

1/2

1/2

Crile-Wood
20-638-20-07
20,5 cm / 8 1/8"



1/1

4-0 - 6-0

Mini



1/1

6-0 - 12-0

Smooth

1/2

Webster
20-637-12-07
12 cm / 4 6/8"



1/1

4-0 - 6-0

Mini

1/2

Crile-Wood
20-638-15-07
15 cm / 5 7/8"

Nadelhalter

Needle Holders

Porta-agujas

Porte-aiguilles

Portaghi

Naht

Suture

Sutura

Suture

Sutura

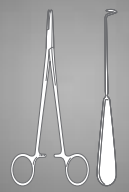

TC GOLD



1/2

Sarot
20-640-18-07 -
20-640-26-07



1/1

20-640-18-07
18 cm / 7 1/8"



0-6 - 4-0



Standard



20-640-20-07
20 cm / 7 7/8"



0-6 - 4-0



Standard



20-640-26-07
26 cm / 10 2/8"



0-6 - 4-0



Standard



1/1

20-642-16-07
16 cm / 6 2/8"



0-6 - 4-0



Standard



20-642-18-07
18,5 cm / 7 2/8"



0-6 - 4-0



Standard



20-642-20-07
20 cm / 7 7/8"



0-6 - 4-0



Standard

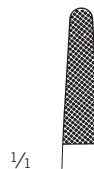

1/1

20-642-24-07
24 cm / 9 4/8"



0-6 - 4-0



Standard



20-642-26-07
26,5 cm / 10 3/8"



0-6 - 4-0



Standard



20-642-30-07
30 cm / 11 6/8"



0-6 - 4-0



Standard



1/2

Mayo-Hegar
20-642-16-07 -
20-642-30-07

Nadelhalter

Needle Holders

Porta-agujas

Porte-aiguilles

Portaghi

TC GOLD



1/2

Heaney
20-643-20-07 -
20-643-26-07



1/1

20-643-20-07
20,5 cm / 8 1/8"

0-6 - 4-0

Standard



20-643-24-07
24 cm / 9 4/8"

0-6 - 4-0

Standard



20-643-26-07
26,5 cm / 10 3/8"

0-6 - 4-0

Standard



1/2

DeBakey
20-646-18-07 -
20-646-31-07

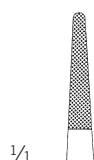

1/1

20-646-18-07
18 cm / 7 1/8"

4-0 - 6-0

Mini



20-646-20-07
20,5 cm / 8 1/8"

4-0 - 6-0

Mini



20-646-23-07
23 cm / 9 "

4-0 - 6-0

Mini



1/1

20-646-26-07
26,5 cm / 10 3/8"

4-0 - 6-0

Mini



20-646-31-07
31 cm / 12 2/8"

4-0 - 6-0

Mini



1/2

Masson
20-648-27-07
26,5 cm / 10 3/8"



1/1

0-6 - 4-0

Standard

Nadelhalter

Needle Holders

Porta-agujas

Porte-aiguilles

Portaghi

Naht

Suture

Sutura

Suture

Sutura

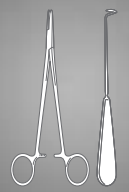

TC GOLD



1/2

Ryder (Martin)
20-650-13-07 -
20-650-26-07

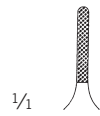

1/1

20-650-13-07
12,5 cm / 4 7/8"



20-650-15-07
15 cm / 5 7/8"



20-650-18-07
18 cm / 7 1/8"

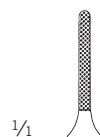

1/1

20-650-20-07
20 cm / 7 7/8"



20-650-23-07
23 cm / 9"



20-650-26-07
26 cm / 10 2/8"



1/1



20



1/2

Finochietto
20-653-27-07
26,5 cm / 10 3/8"
Normalprofil
standard profile
perfil estándar
profil normal
profilo normale



1/2

Martin
20-652-15-07 -
20-652-20-07

elastisches Modell
elastic tip
modelo elástico
modèle souple
modello molle

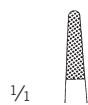

1/1

20-652-15-07
15 cm / 5 7/8"



20-652-17-07
17 cm / 6 5/8"



20-652-20-07
20,5 cm / 8 1/8"



Nadelhalter

Needle Holders

Porta-agujas

Porte-aiguilles

Portaghi

TC GOLD



1/2

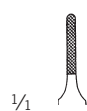

1/1

20-654-13-07
12 cm / 4 5/8"

5-0 - 8-0

Micro



20-654-15-07
15,5 cm / 6 1/8"

5-0 - 8-0

Micro



20-654-18-07
17,5 cm / 6 7/8"

5-0 - 8-0

Micro

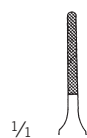

1/1

20-654-20-07
20 cm / 7 7/8"

5-0 - 8-0

Micro



20-654-23-07
22,5 cm / 8 7/8"

5-0 - 8-0

Micro

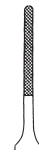

20-654-26-07
26 cm / 10 1/8"

5-0 - 8-0

Micro



1/2

1/1



0-6 - 4-0

Standard

Ryder-Vascular
20-654-13-07 -
20-654-26-07

schlankes Modell
delicate pattern
modelo delgado
modèle gracile
modelo gracile

Wangensteen
20-656-27-07
27 cm / 10 5/8"

Nadelhalter

Needle Holders

Porta-agujas

Porte-aiguilles

Portaghi

Naht

Suture

Sutura

Suture

Sutura

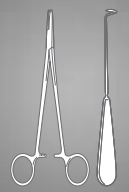

TC GOLD



1/2

Hegar-Vascular
20-658-14-07 -
20-658-23-07

1/1			
20-658-14-07 14 cm / 5 4/8"	20-658-18-07 18,5 cm / 7 2/8"	20-658-20-07 20,5 cm / 8 1/8"	20-658-23-07 23 cm / 9"



1/2

Bozemann
20-659-20-07 -
20-659-28-07

1/1	
20-659-20-07 20,5 cm / 8 1/8"	20-659-24-07 24 cm / 9 4/8"
20-659-26-07 26 cm / 10 4/8"	20-659-28-07 30 cm / 11 6/8"



1/2

Hegar
20-662-20-07 -
20-662-24-07

1/1	
20-662-20-07 20 cm / 7 7/8"	20-662-24-07 24 cm / 9 4/8"

20

Nadelhalter

Needle Holders

Porta-agujas

Porte-aiguilles

Portaghi

TC GOLD



1/1

20-665-22-07

0-6 - 4-0

Standard



20-665-23-07

0-6 - 4-0

Standard



1/2

1/1

20-666-00-07

14 cm / 5 4/8"

5-0 - 8-0

Micro



20-666-02-07

17,5 cm / 6 7/8"

5-0 - 8-0

Micro



20-666-03-07

20 cm / 7 7/8"

5-0 - 8-0

Micro



20-666-04-07

23 cm / 9"

5-0 - 8-0

Micro



20-666-05-07

26 cm / 10 2/8"

5-0 - 8-0

Micro

Stratte
20-665-22-07 -
20-665-23-07
23 cm / 9"

Microvascular
20-666-00-07 -
20-666-05-07



1/2

1/1

20-668-00-07

14 cm / 5 4/8"

5-0 - 8-0

Smooth



20-668-01-07

15 cm / 5 7/8"

5-0 - 8-0

Smooth



20-668-02-07

17,5 cm / 6 7/8"

5-0 - 8-0

Smooth



20-668-03-07

20 cm / 7 7/8"

5-0 - 8-0

Smooth

Martini
20-668-00-07 -
20-668-03-07

Nadelhalter

Needle Holders

Porta-agujas

Porte-aiguilles

Portaghi

Naht

Suture

Sutura

Suture

Sutura

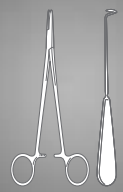

TC GOLD



1/2

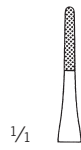

1/1

20-670-00-07

14 cm / 5 4/8"



5-0 - 8-0



Micro



20-670-01-07

15 cm / 5 7/8"

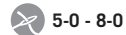

5-0 - 8-0



Micro



20-670-02-07

17,5 cm / 6 7/8"



5-0 - 8-0



Micro



20-670-03-07

20 cm / 7 7/8"



5-0 - 8-0



Micro

Martini
20-670-00-07 -
20-670-03-07

schlankes Modell
delicate pattern
modelo delgado
modèle gracile
modelo gracile



1/2

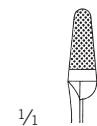

1/1

20-672-14-07

14,5 cm / 5 4/8"



0-6 - 4-0



Standard



20-672-17-07

17 cm / 6 6/8"



0-6 - 4-0



Standard



20-672-18-07

19 cm / 7 4/8"



0-6 - 4-0



Standard

Olsen Hegar
20-672-14-07 -
20-672-18-07

Normalprofil
standard profile
perfil estándar
profil normal
profilo normale

Nadelhalter

Needle Holders



Porta-agujas

Porte-aiguilles

Portaghi

TC GOLD

 <p>1/2</p>	 <p>1/1</p> <p>6-0 - 12-0</p> <p>Smooth</p>	 <p>1/2</p>	 <p>1/1</p> <p>4-0 - 6-0</p> <p>Mini</p>	 <p>1/2</p>	 <p>1/1</p> <p>0-6 - 4-0</p> <p>Standard</p>
<p>Foster-Gillies 20-673-12-07 11 cm / 4 3/8"</p>		<p>Gillies-Mini 20-673-15-07 15 cm / 5 7/8"</p>		<p>Gillies 20-673-16-07 16 cm / 6 2/8"</p>	

 <p>1/2</p>	 <p>1/1</p> <p>20-674-14-07 14 cm / 5 4/8"</p> <p>0-6 - 4-0</p> <p>Standard</p>	 <p>1/1</p> <p>20-674-17-07 17 cm / 6 6/8"</p> <p>0-6 - 4-0</p> <p>Standard</p>	 <p>1/1</p> <p>20-674-20-07 20 cm / 7 7/8"</p> <p>0-6 - 4-0</p> <p>Standard</p>
<p>Mathieu 20-674-14-07 - 20-674-20-07</p>			

Nadelhalter

Needle Holders

Porta-agujas

Porte-aiguilles

Portaghi

Naht

Suture

Sutura

Suture

Sutura

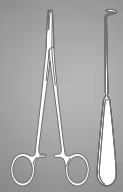

TC GOLD



1/2

Mathieu
20-676-14-07 -
20-676-20-07



20-676-14-07
14 cm / 5 4/8"

0-6 - 4-0

Standard



20-676-17-07
17 cm / 6 5/8"

0-6 - 4-0

Standard



20-676-20-07
20 cm / 7 7/8"

0-6 - 4-0

Standard



1/2

Mathieu
20-678-17-07 -
20-678-23-07

mit Innensperre
with interior ratchet
con cremallera interior
avec crémaillère interne
con cremagliera interna



20-678-17-07
17 cm / 6 5/8"

0-6 - 4-0

Standard



20-678-20-07
20 cm / 7 7/8"

0-6 - 4-0

Standard



20-678-23-07
23 cm / 9"

0-6 - 4-0

Standard



1/2

Toennis
20-684-18-07
18 cm / 7 1/8"



0-6 - 4-0

Standard

20

Nadelhalter

Needle Holders

Porta-agujas

Porte-aiguilles

Portaghi

TC GOLD



1/2

Lichtenberg
20-686-20-07
20 cm / 7 7/8"



1/1

0-6 - 4-0

Standard



1/2

Langenbeck
20-692-18-07 -
20-692-23-07



1/1

20-692-18-07

18,5 cm / 7 2/8"

0-6 - 4-0

Standard



20-692-20-07

20,5 cm / 8 1/8"

0-6 - 4-0

Standard



20-692-23-07

23 cm / 9"

0-6 - 4-0

Standard



1/2



1/1

20-696-20-07

20 cm / 7 7/8"

0-6 - 4-0

Standard



20-696-23-07

23 cm / 9"

0-6 - 4-0

Standard

Zweifel
20-696-20-07 -
20-696-23-07

mit Klappsperr
with hinged ratchet
con cremallera abatible
avec crémaillère repliable
con cremagliera a scatto

Reverdin Nadeln

Reverdin Needles
Agujas de Reverdin
Aguilles de Reverdin
Aghi di Reverdin

Naht

Sutura
Sutura
Suture
Sutura

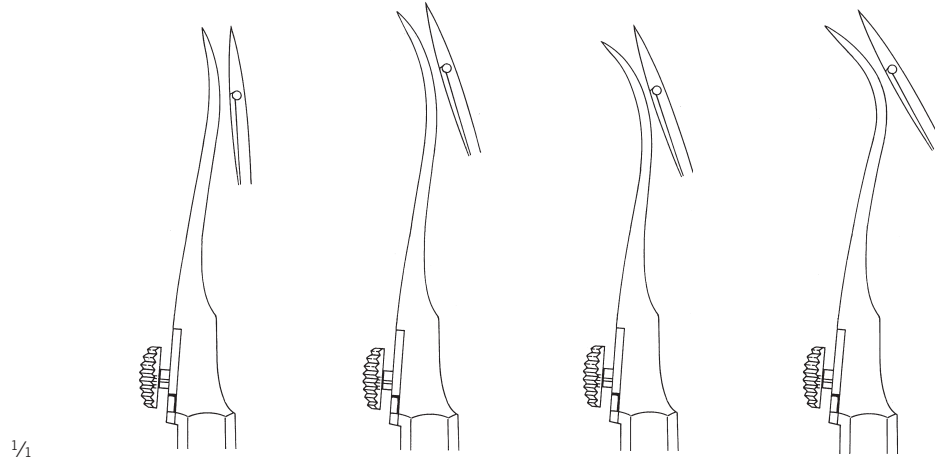

1/1

kurz short corto court corto	Fig. 1 20-701-15-07 14,5 cm / 5 6/8"	Fig. 2 20-702-15-07 14,5 cm / 5 6/8"	Fig. 3 20-703-15-07 14,5 cm / 5 6/8"	Fig. 4 20-704-15-07 14,5 cm / 5 6/8"
--	---	---	---	---

mittel medium medio moyen mediano	Fig. 1 20-721-19-07 20 cm / 7 7/8"	Fig. 2 20-722-19-07 20 cm / 7 7/8"	Fig. 3 20-723-19-07 20 cm / 7 7/8"	Fig. 4 20-724-19-07 20 cm / 7 7/8"
---	---	---	---	---

lang long largo moyen lungo	Fig. 1 20-741-23-07 23 cm / 9"	Fig. 2 20-742-23-07 23 cm / 9"	Fig. 3 20-743-23-07 23 cm / 9"	Fig. 4 20-744-23-07 23 cm / 9"
---	---	---	---	---



1/2

Reverdin
20-701-15-07 -
20-744-23-07

20

Nadelhalter, Unterbindungsnadeln

Needle Holder, Ligature Needles
 Porta-agujas, Agujas para ligaduras
 Porte-aiguilles, Aiguilles à ligatures
 Portaghi, Aghi per legatura

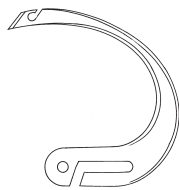

Fig. 1
 20-776-01-07
 Nadelaufsatz
 Spare Needle
 Aguja de repuesto
 Aiguilles de rechange
 Ago di ricambio

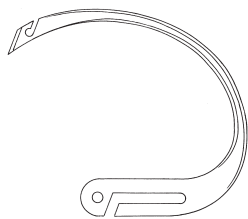

Fig. 2
 20-776-02-07
 Nadelaufsatz
 Spare Needle
 Aguja de repuesto
 Aiguilles de rechange
 Ago di ricambio

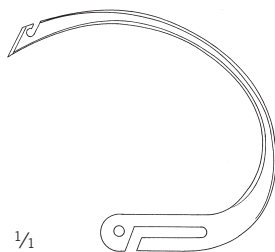

Fig. 3
 20-776-03-07
 Nadelaufsatz
 Spare Needle
 Aguja de repuesto
 Aiguilles de rechange
 Ago di ricambio



1/2

Young
 20-775-25-02
 24,5 cm / 9 3/4"

komplett, mit Nadelaufsatz Fig. 1
 complete, with needle no. 1
 completo, con aguja no. 1
 complet, avec aiguille fig. 1
 completo, con ago fig. 1



1/2

Schmieden-Dick
 20-813-32-07
 30 cm / 11 6/8"

biegsam
 malleable
 maleable
 malléable
 malleabili



1/1



1/2

Schmieden
 20-815-21-07
 24 cm / 9 4/8"

Unterbindungsnadeln

Ligature Needles
Agujas para ligaduras
Aiguilles à ligatures
Aghi per legatura

Naht

Sutura
Sutura
Sutura
Sutura



20-825-20-07

20 cm / 7 7/8"

biegsam
malleable
maleable
malléable
malleabili

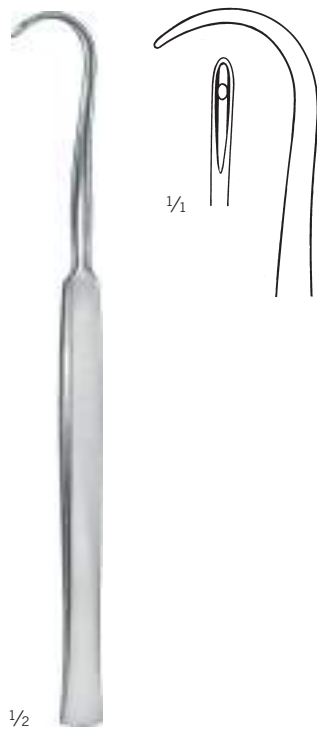

Cooper

20-832-19-07

20 cm / 7 7/8"

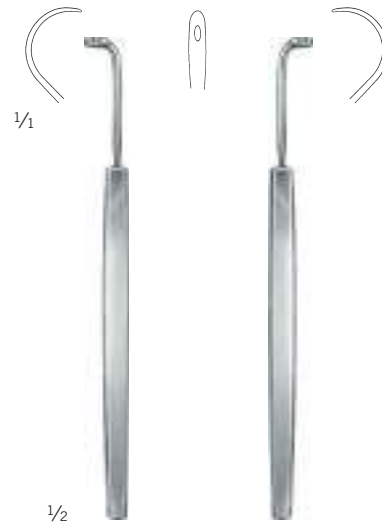

Kronecker

20-835-13-07

12 cm / 4 6/8"

fein, für die rechte Hand
delicate, for right hand
fina, para la mano derecha
fine, pour la main droite
fino, per la mano destra

Kronecker

20-837-13-07

12 cm / 4 6/8"

fein, für die linke Hand
delicate, for left hand
fina, para la mano izquierda
fine, pour la main gauche
fino, per la mano sinistra

Unterbindungsnadeln

Ligature Needles

Agujas para ligaduras

Aiguilles à ligatures

Aghi per legatura



20-839-24-07

24 cm / 9 4/8"

stumpf, für die rechte Hand
blunt, for right hand
roma para la mano derecha
mousse, pour la main droite
smusso, per la mano destra



20-840-24-07

24 cm / 9 4/8"

stumpf, für die linke Hand
blunt, for left hand
roma para la mano izquierda
mousse, pour la main gauche
smusso, per la mano sinistra

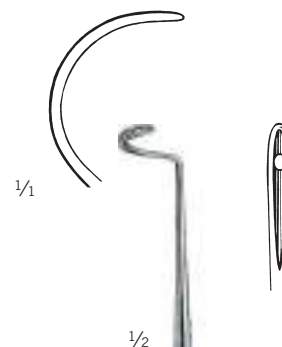

20-841-20-07

20 cm / 7 7/8"

stumpf, für die rechte Hand
blunt, for right hand
roma para la mano derecha
mousse, pour la main droite
smusso, per la mano destra



20-842-20-07

20 cm / 7 7/8"

stumpf, für die linke Hand
blunt, for left hand
roma para la mano izquierda
mousse, pour la main gauche
smusso, per la mano sinistra



1/2

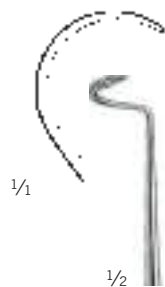

20-843-20-07

20 cm / 7 7/8"

scharf, für die rechte Hand
sharp, for right hand
aguda para la mano derecha
aiguë, pour la main droite
acuto, per la mano destra



20-844-20-07

20 cm / 7 7/8"

scharf, für die linke Hand
sharp, for left hand
aguda para la mano izquierda
aiguë, pour la main gauche
acuto, per la mano sinistra

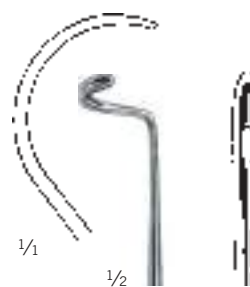

20-845-21-07

20 cm / 7 7/8"

stumpf, für die rechte Hand
blunt, for right hand
roma para la mano derecha
mousse, pour la main droite
smusso, per la mano destra



20-846-21-07

20 cm / 7 7/8"

stumpf, für die linke Hand
blunt, for left hand
roma para la mano izquierda
mousse, pour la main gauche
smusso, per la mano sinistra

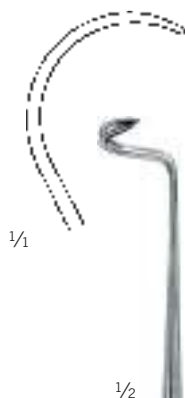

20-847-21-07

20 cm / 7 7/8"

scharf, für die rechte Hand
sharp, for right hand
aguda para la mano derecha
aiguë, pour la main droite
acuto, per la mano destra



20-848-21-07

20 cm / 7 7/8"

scharf, für die linke Hand
sharp, for left hand
aguda para la mano izquierda
aiguë, pour la main gauche
acuto, per la mano sinistra

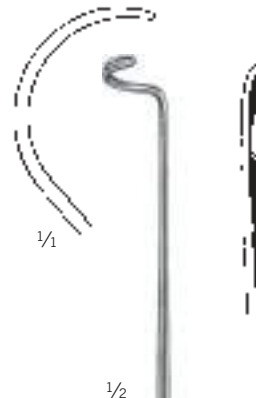

20-849-27-07

27 cm / 10 5/8"

stumpf, für die rechte Hand
blunt, for right hand
roma para la mano derecha
mousse, pour la main droite
smusso, per la mano destra



20-850-27-07

27 cm / 10 5/8"

stumpf, für die linke Hand
blunt, for left hand
roma para la mano izquierda
mousse, pour la main gauche
smusso, per la mano sinistra

Unterbindungsnadeln

Ligature Needles
 Agujas para ligaduras
 Aiguilles à ligatures
 Aghi per legatura

Naht

Suture
 Sutura
 Suture
 Sutura

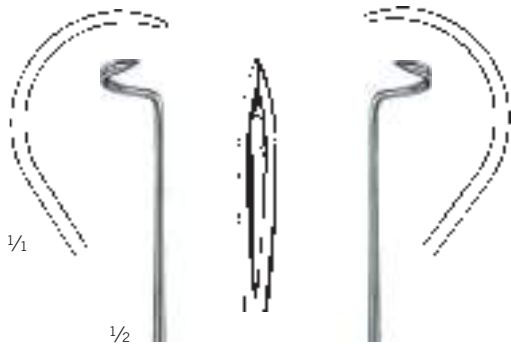
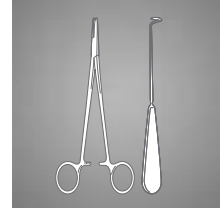

20-851-27-07

27 cm / 10 5/8"

scharf, für die rechte Hand
 sharp, for right hand
 aguda para la mano derecha
 aiguë, pour la main droite
 acuto, per la mano destra



20-852-27-07

27 cm / 10 5/8"

scharf, für die linke Hand
 sharp, for left hand
 aguda para la mano izquierda
 aiguë, pour la main gauche
 acuto, per la mano sinistra

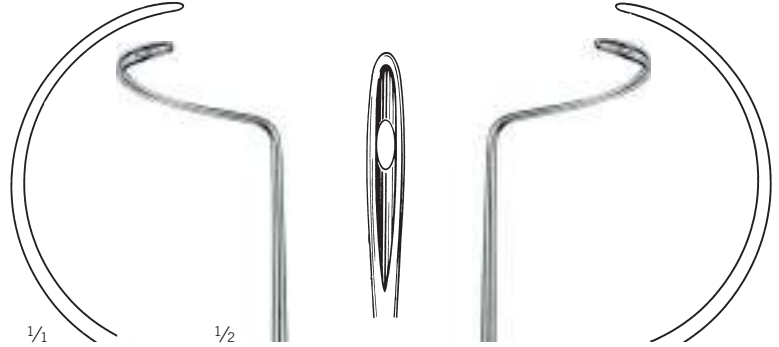

20-853-28-07

28 cm / 11"

stumpf, für die rechte Hand
 blunt, for right hand
 roma para la mano derecha
 mousse, pour la main droite
 smusso, per la mano destra

20-854-28-07

28 cm / 11"

stumpf, für die linke Hand
 blunt, for left hand
 roma para la mano izquierda
 mousse, pour la main gauche
 smusso, per la mano sinistra

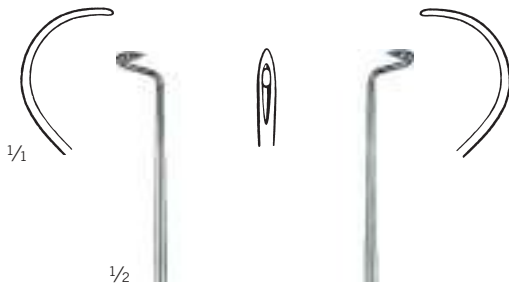

20-855-20-07

21 cm / 8 2/8"

scharf, für die rechte Hand
 sharp, for right hand
 aguda para la mano derecha
 aiguë, pour la main droite
 acuto, per la mano destra



20-856-20-07

21 cm / 8 2/8"

scharf, für die linke Hand
 sharp, for left hand
 aguda para la mano izquierda
 aiguë, pour la main gauche
 acuto, per la mano sinistra

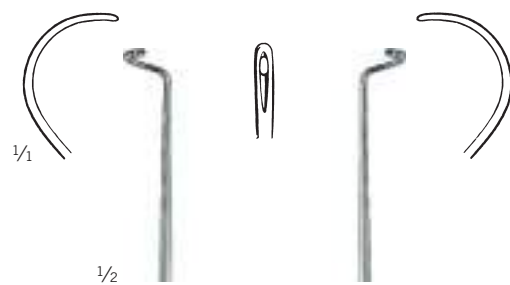

20-857-20-07

21 cm / 8 2/8"

stumpf, für die rechte Hand
 blunt, for right hand
 roma para la mano derecha
 mousse, pour la main droite
 smusso, per la mano destra

20-858-20-07

21 cm / 8 2/8"

stumpf, für die linke Hand
 blunt, for left hand
 roma para la mano izquierda
 mousse, pour la main gauche
 smusso, per la mano sinistra

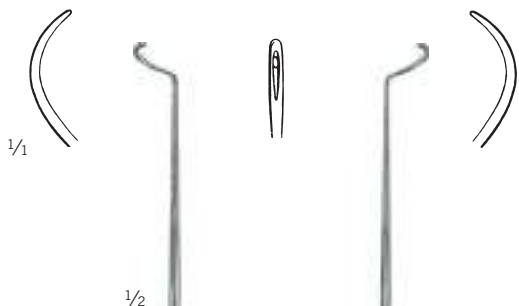

20-859-20-07

21 cm / 8 2/8"

stumpf, für die rechte Hand
 blunt, for right hand
 roma para la mano derecha
 mousse, pour la main droite
 smusso, per la mano destra

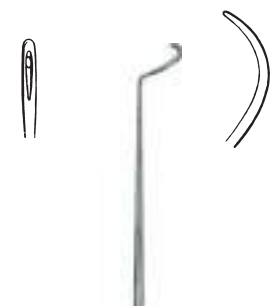

20-860-20-07

21 cm / 8 2/8"

stumpf, für die linke Hand
 blunt, for left hand
 roma para la mano izquierda
 mousse, pour la main gauche
 smusso, per la mano sinistra

Unterbindungsnadeln, Führungshohlsonden

Ligature Needles, Ligature Conductors

Agujas para ligaduras, Sondas conductoras

Aiguilles à ligatures, Sondes conductrices

Aghi per legatura, Sonde conduttrici

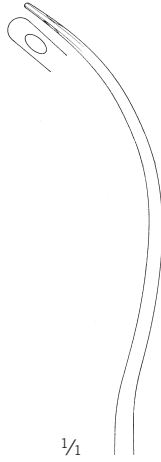

Fig. 1
20-861-30-07

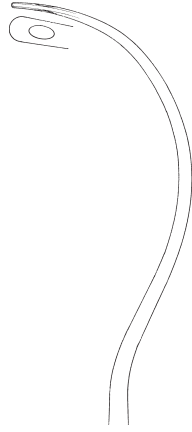

Fig. 2
20-862-30-07

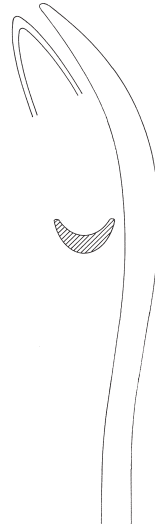

Fig. 1
20-863-30-07

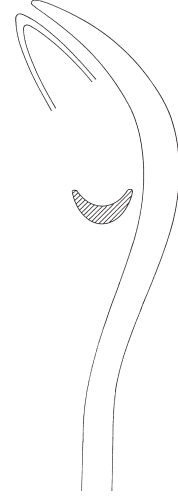

Fig. 2
20-864-30-07

Brunner
20-861-30-07 -
20-864-30-07
30 cm / 11 ⁶/₈"

Führungshohlsonden

Ligature Conductors
Sondas conductoras
Sondes conductrices
Sonde conduttrici

Naht

Suture
Sutura
Suture
Sutura

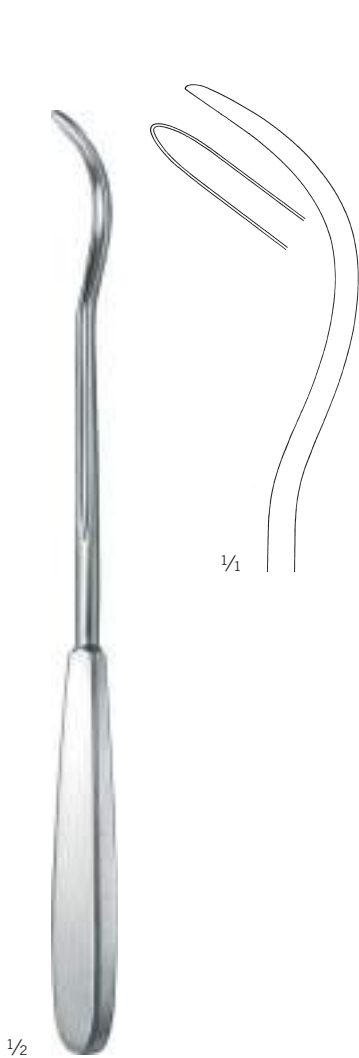
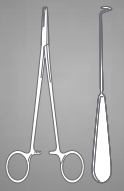

Kirschner
20-865-25-07
25,5 cm / 10"

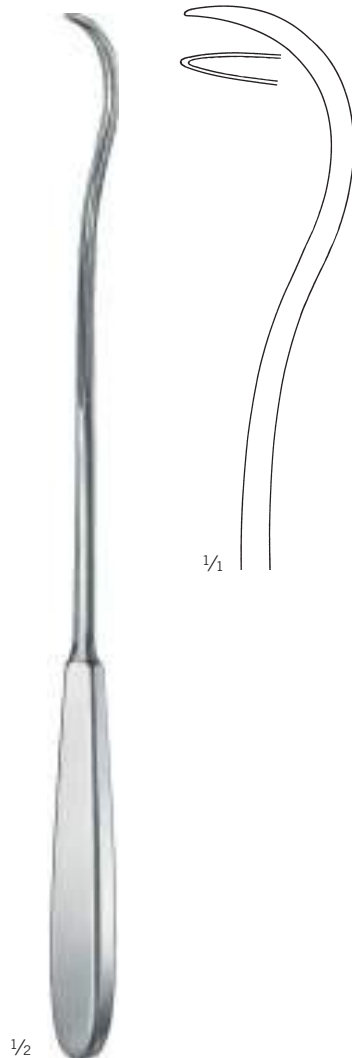

20-866-28-07
28 cm / 11"

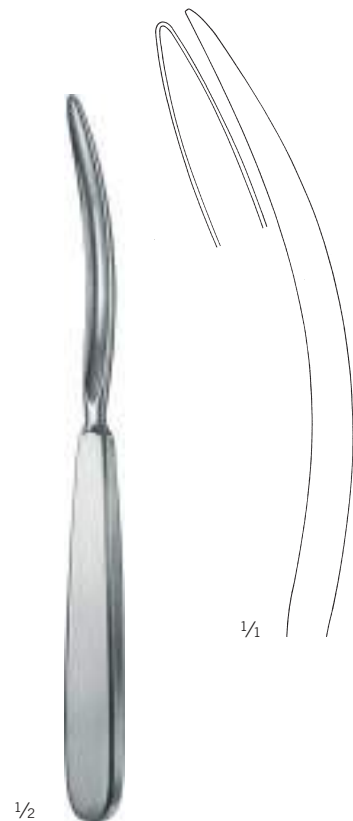

Mod. Martin
20-867-25-07
19,5 cm / 7 5/8"

Führungshohlsonden

Ligature Conductors
 Sondas conductoras
 Sondes conductrices
 Sonde conduttrici



1/2

Brunner
 20-868-18-04
 18 cm / 7 1/8"

Fz



1/3

Kirschner
 20-869-27-04
 27 cm / 10 5/8"

Fz



1/2

20-870-01-04
 19 cm / 7 4/8"

Fz



1/3

20-870-24-04
 24 cm / 9 4/8"

Fz

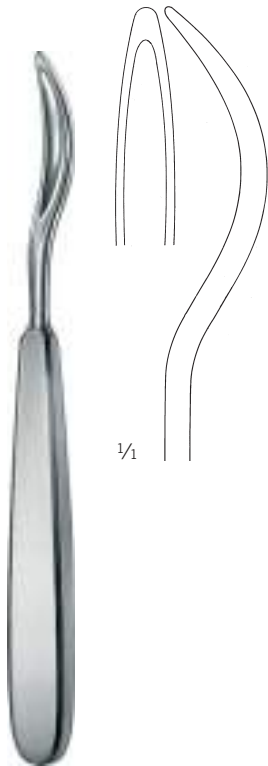

1/1

1/2

Schmieden
 20-871-19-07
 18 cm / 7 1/8"

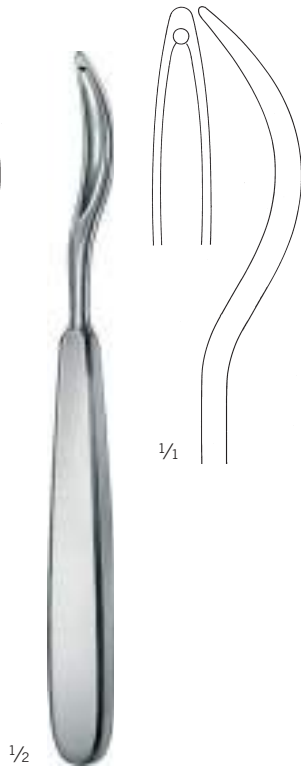

1/1

1/2

Schmieden-Payr
 20-872-19-07
 18 cm / 7 1/8"



1/2

König
 20-875-03-07 -
 20-875-07-07



1/1

20-875-03-07
 20 cm / 7 7/8"
Fig. 1

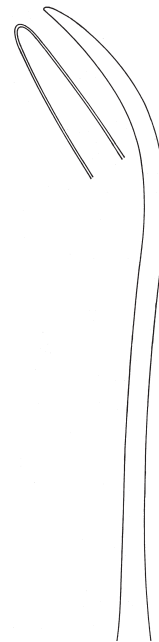

20-875-05-07
 20 cm / 7 7/8"
Fig. 2



20-875-07-07
 20 cm / 7 7/8"
Fig. 3

Führungshohlsonden, Fadenfänger

Ligature Conductors
 Sondas conductoras
 Sondes conductrices
 Sonde conduttrici

Naht
 Suture
 Sutura
 Suture
 Sutura

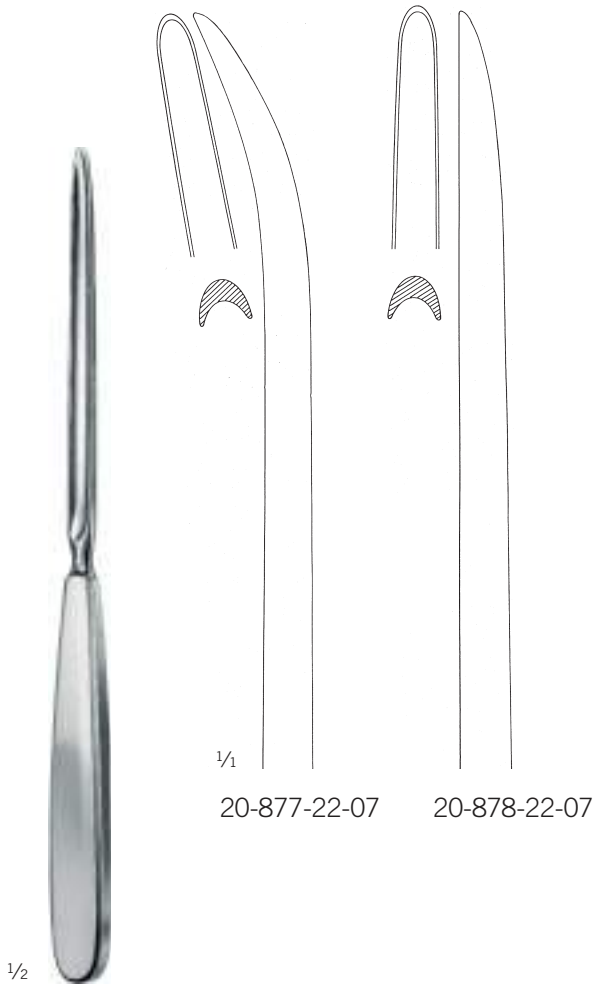

Payr
 20-877-22-07 -
 20-878-22-07
 22 cm / 8 5/8"



Modell Wien
 20-882-23-07
 23,5 cm / 9 2/8"
 Fadenfänger
 Ligature Catcher
 Captador de hilos
 Porte-ligature
 Portalegature



Bozemann
 20-884-21-07
 22 cm / 8 5/8"
 Schlingendreher
 Knot Tier
 Tuerce-lazos
 Tords-fil
 Torcifilo



20-886-23-07
 23 cm / 9"
 Fadengabel
 Ligature Adjuster
 Horquilla de hilos
 Pousse-fil
 Forchetta da sutura

20

Wundklammerpinzetten, Wundklammerzängchen

Clip Applying Forceps

Pinzas aplicadoras para agrafes

Pinces à poser les agrafes

Pinze per applicare le agrafe



1/2

Childe
20-910-18-07

17 cm / 6 5/8"

Wundrandpinzette
Approximation Forceps
Pinza aproximadora
Pinces à poser les agrafes
Pinza per i margini della ferita
kräftig, mit Klammerschiene
heavy pattern, with clip holder
modelo fuerte, con barra para agrafes
modèle fort, avec porte-agrales
modello forte, con portaagrafes



1/2

Michel
20-916-12-07

12 cm / 4 5/8"



1/2

Hegenbarth
20-922-12-07

12 cm / 4 5/8"



1/2

Wachenfeldt
20-924-12-07

12 cm / 4 5/8"



1/2

➔ 20-940-01-01-
20-940-09-01

Michel
20-928-12-07

12,5 cm / 4 7/8"

zum Anlegen und Abnehmen von Klammern
for applying and removal of clips
para aplicar y quitar agrafes
pour appliquer et enlever les agrafes
per applicare e togliere le agrafes



1/2

➔ 20-940-01-01-
20-940-09-01

Michel
20-929-12-07

13 cm / 4"

langes Maul, zum Anlegen und Abnehmen
von Klammern
long jaw, for applying and removal of clips
boca larga, para aplicar y quitar agrafes
pour appliquer et enlever les agrafes
morso lungo, per applicare e togliere
le agrafes



1/2

Richter
20-935-14-07

13,5 cm / 5 3/8"

mit Schraubschluß
screw lock
articulación a tornillo
articulation à vis
articulazione a vite

Führungshohlsonden, Fadenfänger

Ligature Conductors
 Sondas conductoras
 Sondas conductrices
 Sonde conduttrici

Naht
 Sutura
 Sutura
 Suture
 Sutura

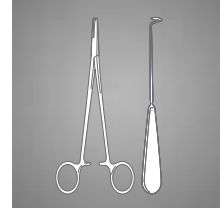

1/2

Michel

20-940-01-01 -
 20-940-08-01

	20-940-01-01 = 7,5 x 1,75 mm
	20-940-02-01 = 11 x 2,0 mm
	20-940-04-01 = 12 x 3,0 mm
	20-940-05-01 = 14 x 3,0 mm
	20-940-06-01 = 16 x 3,0 mm
	20-940-07-01 = 18 x 3,0 mm
	20-940-08-01 = 20 x 3,0 mm



VE = 1000 Stück
 (10 Packungen mit je 100 Stück)
 SU = 1000/pack
 (10 packages with 100 each)
 UV = 1000 piezas
 (10 paquetes con 100 piezas)
 UC = 1000 untiés
 (10 paquets avec 100 pièces)
 UV = 1000 pezzi
 (10 pacchetti con 100 pezzi)

➔ 20-928-12-07,
 20-929-12-07

Set Kleine „Wundversorgung“

“Small Suture Set”

Set “Sutura pequeña”

Set «Suture petite»

Set “Piccole ferrite”



20-972-00-07

	komplett, in <i>MicroStop</i>®-Miniset-Sterilcontainer, bestehend aus:	complete, in <i>MicroStop</i>®-Miniset-Container, consisting of:	completo en contenedor <i>MicroStop</i>®-Miniset, compuesto de:
1 10-130-03-07	Skalpelloff, Nr. 3	Scalpel handle, No. 3	Mango de bisturí, no. 3
1 11-107-14-07	Chirurgische Schere, spitz/stumpf, gebogen, 14,5 cm	Operating scissors, sharp/blunt, curved, 14,5 cm	Tijera quirúrgica, puntiaguda/romo, curva, 14,5 cm
1 11-255-14-07	Präparierschere, stumpf/stumpf, gebogen, 14,5 cm	Dissecting scissors, blunt/blunt, curved, 14,5 cm	Tijera de disección, romo/romo, curva, 14,5 cm
1 12-301-14-07	Chirurgische Pinzette, 1:2 Zähne, 14,5 cm	Dissecting forceps, 1:2 teeth, 14,5 cm	Pinza de disección, 1:2 dientes, 14,5 cm
1 12-321-14-07	Chirurgische Pinzette, 1:2 Zähne, schmal, 14,5 cm	Dissecting forceps, 1:2 teeth, narrow, 14,5 cm	Pinza de disección, 1:2 dientes, delgado, 14,5 cm
1 12-126-14-07	Anatomische Pinzette, fein, 14,5 cm	Dressing forceps, delicate, 14,5 cm	Pinza de disección, delgado, 14,5 cm
1 12-630-09-07	Splitterpinzette nach Feilchenfeldt, 9 cm	Splinter forceps, Feilchenfeldt, 9 cm	Pinza para espinas, Feilchenfeldt, 9 cm
2 13-923-10-07	Tuchklemmen nach Tohoku, stumpf, 10 cm	Towel clamp, Tohoku, blunt, 10 cm	Pinza de campo, Tohoku, roma, 10 cm
2 13-311-12-07	Mosquito Arterienklemmen, gebogen, 12,5 cm	Mosquito artery forceps, curved, 12,5 cm	Mosquito pinza hemostática, curva, 12,5 cm
1 13-375-16-07	Arterienklemme nach Pean, grazil, gebogen, 16 cm	Artery forceps, Pean, delicate, curved, 16 cm	Pinza hemostática, Pean, delgado, curva, 16 cm
1 13-385-16-07	Arterienklemme nach Kocher, 1:2 Zähne, gebogen, 16 cm	Artery forceps, Kocher, 1:2 teeth, curved, 16 cm	Pinza hemostática, Kocher, 1:2 dientes, curva, 16 cm
1 14-222-22-07	Kornzange nach Gross-Maier, gerade, 22 cm	Dressing forceps, Gross-Maier, straight, 22 cm	Pinza para vendajes, Gross-Maier, recta, 22 cm
1 20-638-15-07	TC-Nadelhalter nach Crile-Wood, 15 cm	TC-Needleholder, Crile-Wood, 15 cm	TC-Porta-aguja, Crile-Wood, 15 cm
2 15-100-02-07	Wundhaken, fein, scharf, 2-zinkig, 16 cm	Hooklets, delicate, sharp, 2 prongs, 16 cm	Ganchitos, fino, acuto, 2 dientes, 16 cm
1 15-751-13-07	Wundspreizer, stumpf, 3:4 Zähne, 13 cm	Wound spreader, blunt, 3:4 teeth, 13 cm	Separador autostático, roma, 3:4 dientes, 13 cm
1 56-231-06-07	Metallschale, rund, 61 x 30 mm, 0,07 l	Round dish, 61 x 30 mm, 0,07 l	Cubeta redonda, 61 x 30 mm, 0,07 l
1 55-861-50-04	<i>MicroStop</i> ®-Miniset-Sterilcontainer, 301 x 189 x 41 mm	<i>MicroStop</i> ®-Miniset-Container, 301 x 189 x 41 mm	Contenedor <i>MicroStop</i> ®-Miniset, 301 x 189 x 41 mm
1 55-864-05-04	Codierschild für Miniset-Sterilcontainer, mit Beschriftung	Identification label for Miniset-Container, with text	Rótulo de identificación para contenedor-Miniset, con etiquetar
1 55-996-59-04	Einschlagtuch, 50 x 50 cm	Wrapping towel, 50 x 50 cm	Pano, 50 x 50 cm
1 55-009-06-04	Spannrahmen für Miniset-Container	Spring frame for Miniset-Container	Bastidor de fijación para contenedor-Miniset

Set Kleine „Wundversorgung“

“Small Suture Set”

Set “Sutura pequeña”

Set «Suture petite»

Set “Piccole ferrite”

Naht

Suture

Sutura

Suture

Sutura

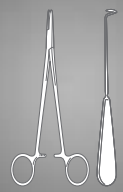

	complète, en conteneur <i>MicroStop</i>®-Miniset, composée de:	completo in contenitore <i>MicroStop</i>®-Miniset, composto di:
1 10-130-03-07	Manche à bistouri, no. 3	Manico per bisturi, no. 3
1 11-107-14-07	Ciseaux chirurgicaux, pointu/moussé, courbé, 14,5 cm	Forbici per chirurgia, acuto/smussato, curva, 14,5 cm
1 11-255-14-07	Ciseaux à dissection, moussé/moussé, courbé, 14,5 cm	Forbici per dissezione, smussato/smussato, curva, 14,5 cm
1 12-301-14-07	Pince à dissection, 1:2 dents, 14,5 cm	Pinza per dissezione, 1:2 denti, 14,5 cm
1 12-321-14-07	Pince à dissection, 1:2 dents, gracile, 14,5 cm	Pinza per dissezione, 1:2 denti, delicato, 14,5 cm
1 12-126-14-07	Pince à dissection, gracile, 14,5 cm	Pinza per dissezione, delicato, 14,5 cm
1 12-630-09-07	Pince à échardes, Feilchenfeldt, 9 cm	Pinza per scheggie, Feilchenfeldt, 9 cm
2 13-923-10-07	Pince à champs, Tohoku, moussé, 10 cm	Pinza fissatele, Tohoku, smussato, 10 cm
2 13-311-12-07	Pincés hémostatiques Mosquito, courbées, 12,5 cm	Pinze emostatiche Mosquito, curve, 12,5 cm
1 13-375-16-07	Pince hémostatique, Pean, gracile, courbé, 16 cm	Pinza emostatica, Pean, delicato, curva, 16 cm
1 13-385-16-07	Pince hémostatique, Kocher, 1:2 dents, courbé, 16 cm	Pinza emostatica, Kocher, 1:2 denti, curva, 16 cm
1 14-222-22-07	Pince à pansements, Gross-Maier, droite, 22 cm	Pinza per medicature, Gross-Maier, retto, 22 cm
1 20-638-15-07	TC-Porte-aiguille, Crile-Wood, 15 cm	TC-Portaghi, Crile-Wood, 15 cm
2 15-100-02-07	Crochets, gracile, pointu, 2 dents, 16 cm	Divaricatori, delicato, acuto, 2 denti, 16 cm
1 15-751-13-07	Ecarteur autostatique, moussé, 3:4 dents, 13 cm	Divaricatori, autostatico, smussato, 3:4 denti, 13 cm
1 56-231-06-07	Cuvette ronde, 61 x 30 mm, 0,07 l	Scodella rotondo, 61 x 30 mm, 0,07 l
1 55-861-50-04	Conteneur <i>MicroStop</i> ®-Miniset, 301 x 189 x 41 mm	Contenitore <i>MicroStop</i> ®-Miniset, 301 x 189 x 41 mm
1 55-864-05-04	Étiquette d'identification pour conteneur-Miniset, avec l'étiquetage	Targhetta di identificazione per contenitore-Miniset, con scritta
1 55-996-59-04	Toile à bacher, 50 x 50 cm	Telo, 50 x 50 cm
1 55-009-06-04	Cadre tendeur pour conteneur-Miniset	Telaio per contenitore-Miniset

Verband
Dressings
Vendajes
Pansements
Bendaggi

21

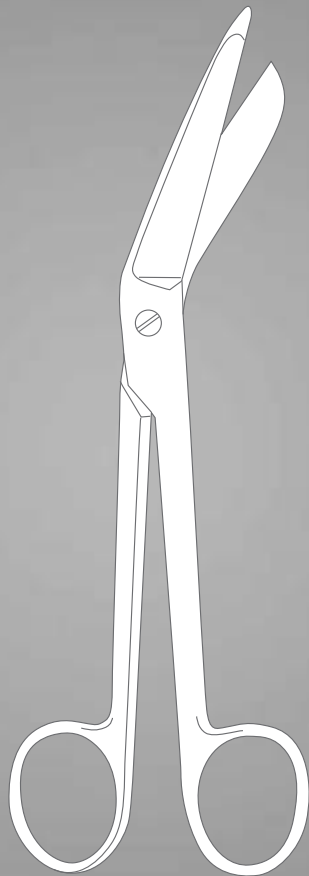

Verbandscheren

Bandage Scissors

Tijeras para vendajes

Ciseaux pour pansements

Forbici per bendaggi

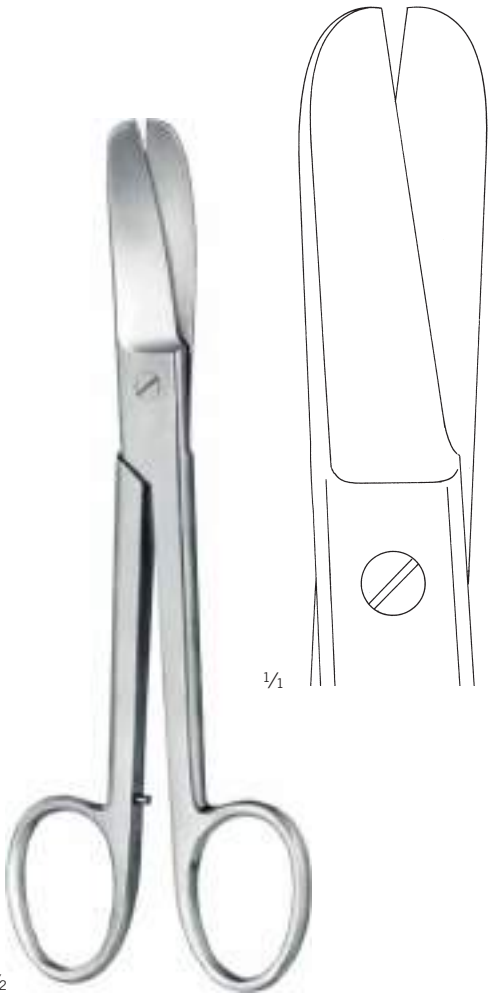

1/2

Lorenz
21-155-23-07
24 cm / 9 4/8"

kräftiges Modell
heavy pattern
modelo fuerte
modèle fort
modello forte

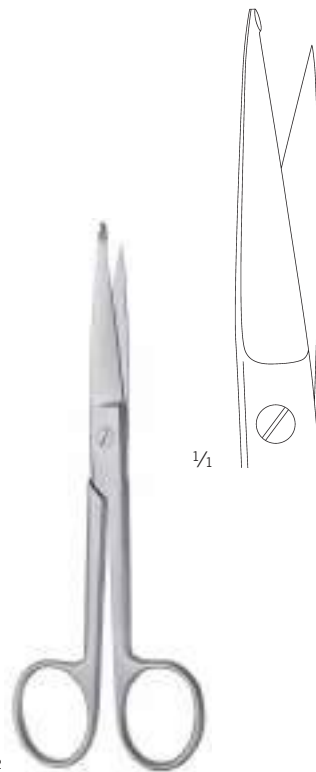

1/2

21-160-14-07
14,5 cm / 5 6/8"

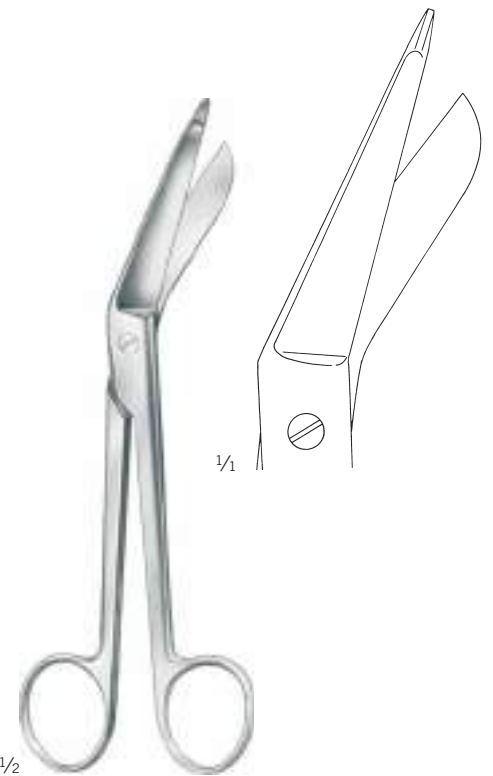

1/2

Lister
21-165-14-07 -
21-165-20-07

21-165-14-07 14,5 cm / 5 6/8"

21-165-18-07 18,5 cm / 7 2/8"

21-165-20-07 20 cm / 7 7/8"

Gipsscheren

Plaster Shears
Tijeras para yeso
Ciseaux pour plâtre
Forbici per gesso

Verband

Dressings
Vendajes
Pansements
Bendaggi

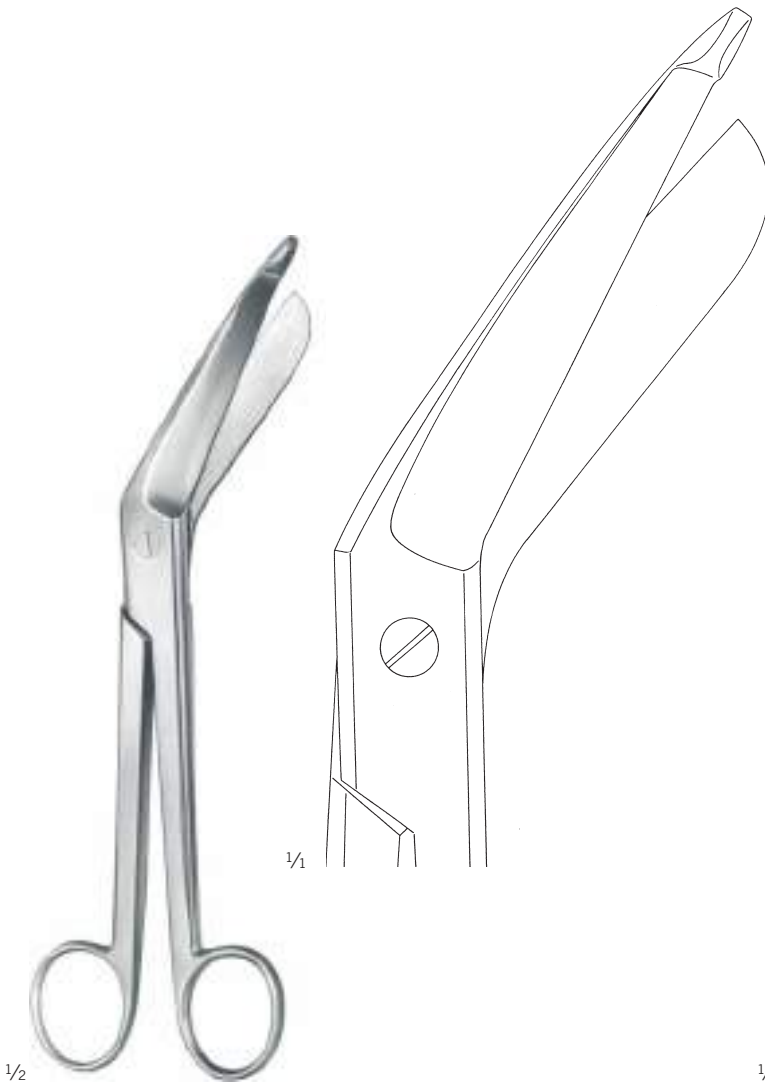

1/2

Bergmann 21-195-23-07

23 cm / 9"

kräftiges Modell
heavy pattern
modelo fuerte
modèle fort
modello forte



1/2

Esmarch 21-205-20-07

20 cm / 7 7/8"

kräftiges Modell, kurze Blätter
heavy pattern, short blades
modelo fuerte, hojas cortas
modèle fort, lames courtes
modello forte, lame curve

21

Verbandscheren, Gipsscheren

Bandage Scissors, Plaster Shears

Tijeras para vendajes, Tijeras para yeso

Ciseaux pour pansements, Ciseaux pour plâtre

Forbici per bendaggi, Forbici per gesso

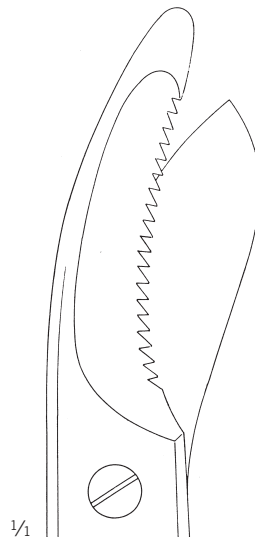

21-223-24-07

eine Schneide gezahnt
one toothed cutting edge
una hoja dentada
une lame dentelée
una lama dentata



21-223-26-07



Universal

21-209-15-01 = 15,5 cm / 6 1/8"

21-209-18-01 = 19 cm / 7 4/8"

schwarze Kunststoffringe, autoklavierbar
black plastic rings, autoclavable

anillos negros, plástico, autoclavable

avec anneaux en matière plastique noire, autoclavable

anelli neri di materia plastica, sterilizzabile in autoclave



Bruns

21-223-24-07 -

21-223-26-07

24 cm / 9 4/8"

Gipsscheren

Plaster Shears
Tijeras para yeso
Ciseaux pour plâtre
Forbici per gesso

Verband

Dressings
Vendajes
Pansements
Bendaggi

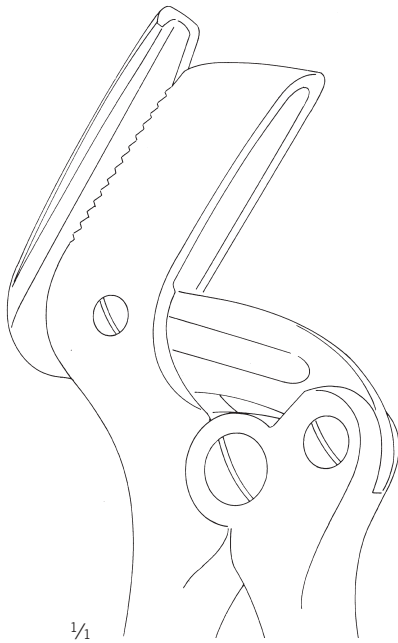

1/1

21-275-23-07
23 cm / 9"

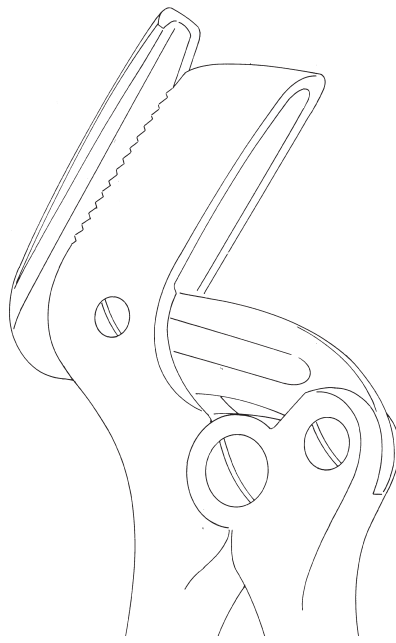

21-275-26-07
27 cm / 10 5/8"

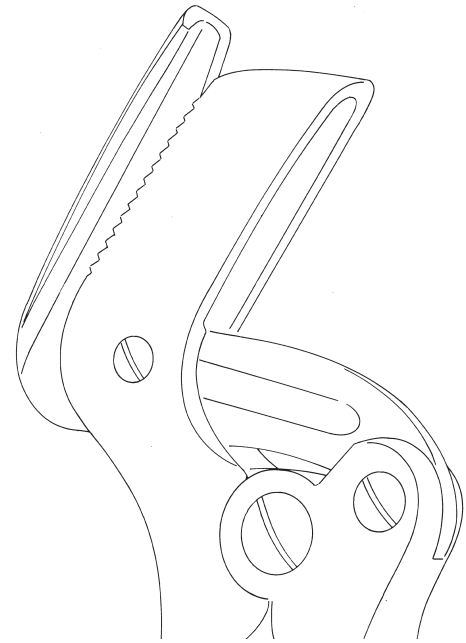

21-275-37-07
38 cm / 15"



1/2

Stille-Martin
21-275-23-07 -
21-277-37-07

Ersatzmesser
Spare Blade
Hoja de recambio
Lame de rechange
Lama di ricambio

21-277-23-07	➔	21-275-23-07
21-277-26-07	➔	21-275-26-07
21-277-37-07	➔	21-275-37-07

Verbandscheren, Gipsscheren

Bandage Scissors, Plaster Shears

Tijeras para vendajes, Tijeras para yeso

Ciseaux pour pansements, Ciseaux pour plâtre

Forbici per bendaggi, Forbici per gesso

TC GOLD



Lister
21-291-18-07
18 cm / 7 1/8"



Bruns
21-297-24-07
23,5 cm / 9 2/8"

Gipsmesser

Plaster Knives

Cuchillos para yeso

Couteaux pour plâtre

Coltelli per gesso

Verband

Dressings

Vendajes

Pansements

Bendaggi



1/2

Hopkins
21-401-20-07

20 cm / 7 7/8"

mit Holzheft
with wooden handle
con mango de madera
avec manche en bois
con manico di legno



1/2

Esmarch
21-420-18-07

18 cm / 7 1/8"



1/2

Reiner
21-425-18-07

18 cm / 7 1/8"



1/2

Martin
21-431-21-07

20,5 cm / 8 1/8"

mit Holzheft
with wooden handle
con mango de madera
avec manche en bois
con manico di legno

Gipsspreizer

Plaster Spreaders

Separadores para yeso

Pinces pour plâtre

Pinze per gesso



Hennig
21-520-28-07
28 cm / 11"

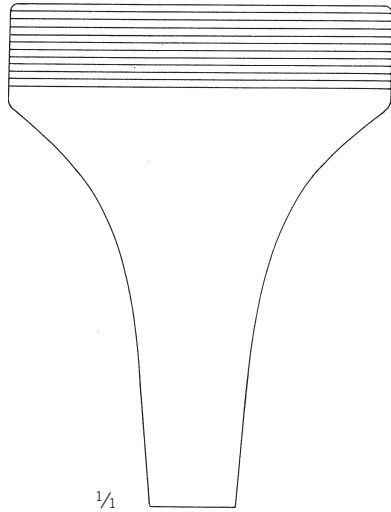

Quattro
21-522-23-07
23 cm / 9"

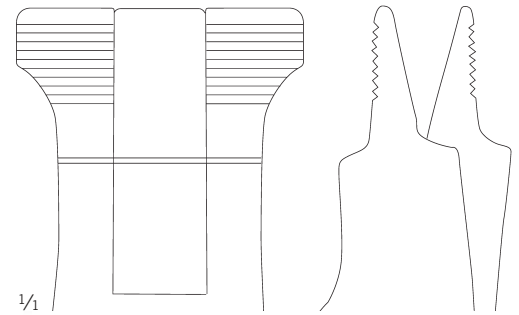

Gipsabreißzangen

Plaster Breakers

Pinzas para romper yeso

Pinces pour rompre plâtre

Pinze per rompere gesso

Verband

Dressings

Vendajes

Pansements

Bendaggi



1/2

Wolff
21-541-18-07 -
21-545-24-07

1/4

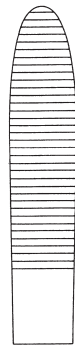

21-541-18-07
17,5 cm / 6 7/8"

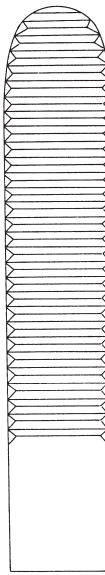

21-545-24-07
26,5 cm / 10 3/8"

21

Oszillierende Gipssäge, Nasenschiene

Oscillating Plaster Saw, Nasal Splint

Sierra oscilante para yeso, Ferula para la nariz

Scie oscillante, Pincers pour rompre plâtre

Sega oscillata per gesso, Stecca per il naso



21-551-00-04 -
21-551-01-04

21-551-00-04 21-551-01-04

230 V 110 V
1,5 kg 1,5 kg

komplett mit 2 Sägeblättern und 2 Schraubenschlüsseln
Schutzklasse II nach DIN EN 60601
Motorschutzschalter funkentstört und schutzisoliert

complete with 2 saw blades and 2 wrenches
safety class II acc. to DIN EN 60601
overload protection interferences suppression
and shockproof

completo con 2 hojas de sierra y 2 llaves de tuercas
clase II de protección según DIN EN 60601
protección contra sobrecarga supresión de las
interferencias y aislamiento protector

complet avec 2 lames de scie et clé à écrou classe II
de sécurité selon DIN EN 60601
disjoncteur-protecteur antiparasité et double isolation

completa con 2 lame e 2 chiavi Classe II di protezione
DIN EN 60601
Interruttore di protezione suppressione d'interferenze
e isolato

21-553-50-07 -
21-553-65-07

Sägeblatt rund, für Gips und Hartverbände
Saw Blade round, for plaster of paris and synthetic casts
Hoja de sierra rond, pour plâtre régulier et synthétique
Lame de scie rond, pour plâtre régulier et synthétique
Lama da sega rotonda, per ingessatura e bendaggi duri

21-553-50-07 = 50 mm Ø

21-553-65-07 = 65 mm Ø

Knochenchirurgie
Bone Surgery
Cirugía ósea
Chirurgie osseuse
Chirurgia ossea

22

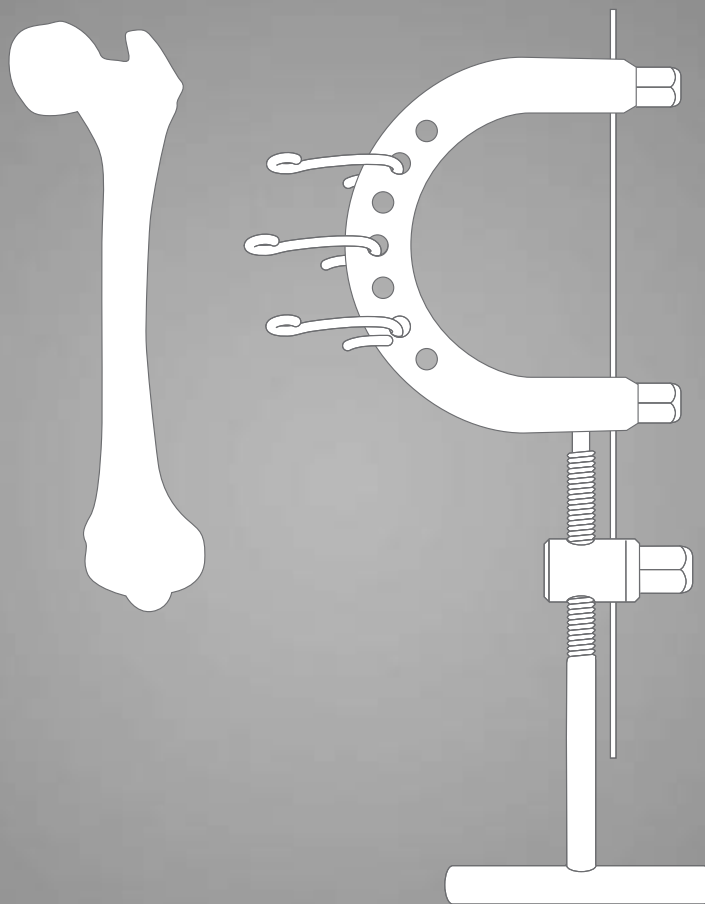

Unser Katalog „Produktübersicht Traumatologie“ enthält die gesamte Palette der KLS-Martin-Instrumente für die Knochenchirurgie

Our catalog “Product Overview Traumatology” contains the full range of KLS-Martin implants and instruments for bone surgery.

Nuestro catálogo “Product Overview Traumatology” incluye la gama completa de los implantes e instrumentos de KLS-Martin para la cirugía ósea.

Notre catalogue «Product Overview Traumatology» contient l'ensemble de la palette des implants et instruments KLS Martin pour la chirurgie osseuse

Il nostro catalogo “Product Overview Traumatology” contiene la gamma completa degli impianti e degli strumenti di KLS Martin per la chirurgia ossea

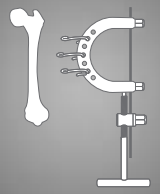

Knochenchirurgie
Bone Surgery
Cirugía ósea
Chirurgie osseuse
Chirurgia ossea

23

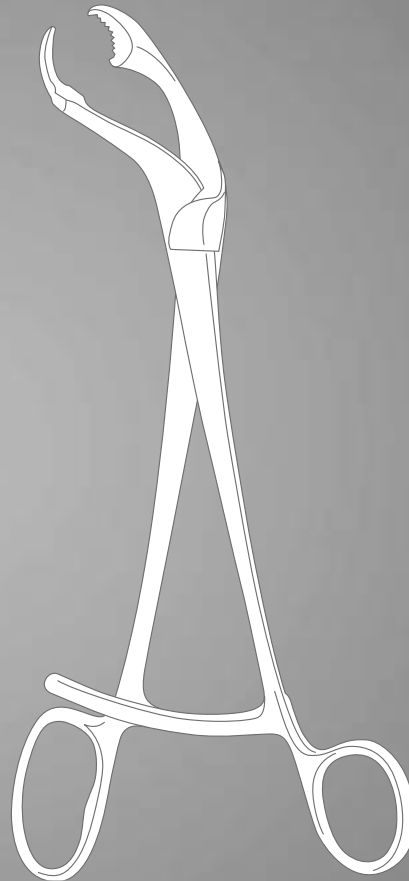
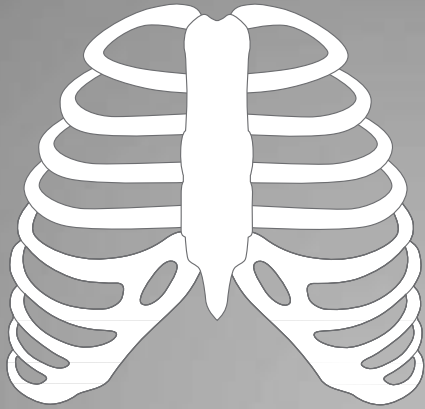

Knochenmeißel, Hohlmeißel

Bone Chisels, Gouges
 Cinceles, Gubias
 Ciseaux-burins, Gouges
 Scalpelli, Sgorbie



1/2

Virchow
 23-036-00-07
 7,5 cm / 3"
 Schädelspalter
 Skull Breaker
 Cincel rompe-cráneo
 Burin pour le crâne
 Scalpello per cranio



1/2

23-072-04-07 -
 23-074-04-07
 17 cm / 6 5/8"

1/1

4 mm
 23-072-04-07

4 mm
 23-074-04-07



1/2

Gardner
 23-076-01-07 -
 23-076-03-07
 17 cm / 6 5/8"
 dreieckige Form
 triangular shape
 forma triangulada
 forme triangulaire
 forma triangolare

1/1

4 mm
 23-076-01-07

4 mm
 23-076-02-07

4 mm
 23-076-03-07



1/2

Snyder-O.S.U
 23-080-03-07 -
 23-080-05-07
 16,5 cm / 6 1/2"

1/1

3 mm
 23-080-03-07

5 mm
 23-080-05-07

Osteotome, Flachmeißel, Hohlmeißel

Osteotomes, Chisels, Gouges
 Osteótomos, Cinceles, Gubias
 Ostéotomes, Ciseaux-burins, Gouges
 Osteotomi, Scalpelli, Sgorbie

Knochenchirurgie

Bone Surgery
 Cirugía ósea
 Chirurgie osseuse
 Chirurgia ossea

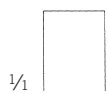
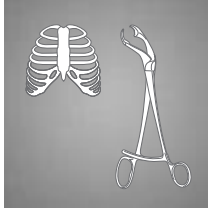

8 mm
 23-100-08-07

1/1

8 mm
 23-101-08-07

1/1

8 mm
 23-102-08-07



10 mm
 23-100-10-07

10 mm
 23-101-10-07

10 mm
 23-102-10-07

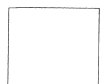

12 mm
 23-100-12-07

12 mm
 23-101-12-07

12 mm
 23-102-12-07



14 mm
 23-100-14-07



14 mm
 23-101-14-07



14 mm
 23-102-14-07

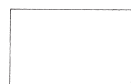

16 mm
 23-100-16-07

16 mm
 23-101-16-07

16 mm
 23-102-16-07

1/2

23-100-08-07 -
 23-100-16-07
 13,5 cm / 5 3/8"

1/2

23-101-08-07 -
 23-101-16-07
 13,5 cm / 5 3/8"

1/2

23-102-08-07 -
 23-102-16-07
 13,5 cm / 5 3/8"

23

Flachmeißel, Hohlmeißel

Chisels
Cinceles
Ciseaux-burins
Scalpelli



2 mm
23-105-02-07
13,5 cm / 5 3/8"



2 mm
23-106-02-07
17 cm / 6 6/8"



2 mm
23-109-02-07
13,5 cm / 5 3/8"



2 mm
23-110-02-07
16,5 cm / 6 4/8"



3 mm
23-105-03-07
13,5 cm / 5 3/8"



3 mm
23-106-03-07
17 cm / 6 6/8"



3 mm
23-109-03-07
13,5 cm / 5 3/8"



3 mm
23-110-03-07
16,5 cm / 6 4/8"



4 mm
23-105-04-07
13,5 cm / 5 3/8"



4 mm
23-106-04-07
17 cm / 6 6/8"



4 mm
23-109-04-07
13,5 cm / 5 3/8"



4 mm
23-110-04-07
16,5 cm / 6 4/8"



5 mm
23-105-05-07
13,5 cm / 5 3/8"



5 mm
23-106-05-07
17 cm / 6 6/8"



5 mm
23-109-05-07
13,5 cm / 5 3/8"



5 mm
23-110-05-07
16,5 cm / 6 4/8"



6 mm
23-105-06-07
13,5 cm / 5 3/8"



6 mm
23-106-06-07
17 cm / 6 6/8"



6 mm
23-109-06-07
13,5 cm / 5 3/8"



6 mm
23-110-06-07
16,5 cm / 6 4/8"



1/2

Partsch
23-105-02-07 -
23-106-06-07



1/2

Partsch
23-109-02-07 -
23-110-06-07

Flachmeißel, Hohlmeißel

Chisels
Cinceles
Ciseaux-burins
Scalpelli

Knochenchirurgie

Bone Surgery
Cirugía ósea
Chirurgie osseuse
Chirurgia ossea

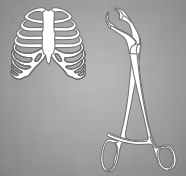

1/1

4 mm
23-118-04-07

1/1

4 mm
23-119-04-07

6 mm
23-118-06-07

6 mm
23-119-06-07

8 mm
23-118-08-07

8 mm
23-119-08-07

10 mm
23-118-10-07

10 mm
23-119-10-07

12 mm
23-118-12-07

12 mm
23-119-12-07

14 mm
23-118-14-07

14 mm
23-119-14-07

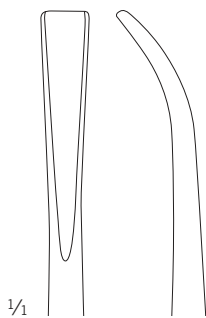

5,5 mm
23-112-05-04



9 mm
23-112-09-04



1/2

Zielke
23-112-05-04 -
23-112-09-04
23 cm / 9"



1/2

Alexander
23-118-04-07 -
23-118-14-07
17,5 cm / 6 7/8"
massiv
solid
macizo
solide
pieno



1/2

Alexander
23-119-04-07 -
23-119-14-07
17,5 cm / 6 7/8"
massiv
solid
macizo
solide
pieno

Flachmeißel, Osteotome

Chisels, Osteotomes

Cinceles, Osteótomos

Ciseaux-burins, Ostéotomes

Scalpelli, Osteotomi, Sgorbie

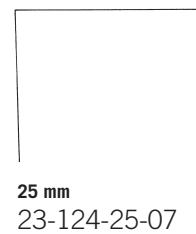
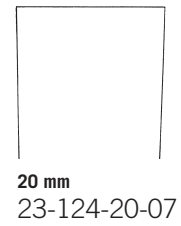
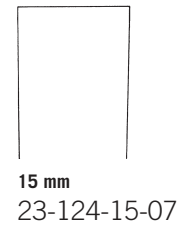
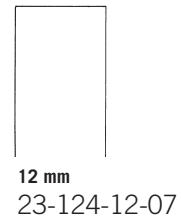
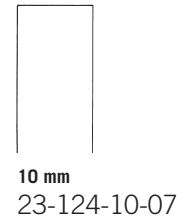
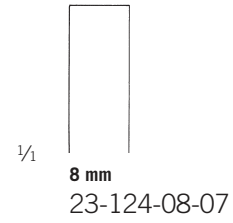
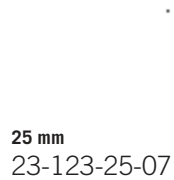
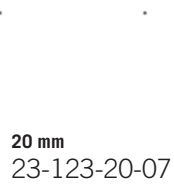
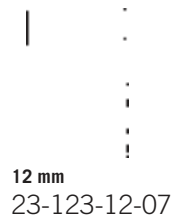
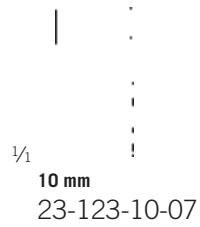

Stille
23-123-10-07 -
23-123-25-07
20,5 cm / 8 1/8"



Stille
23-124-08-07 -
23-124-25-07
20,5 cm / 8 1/8"

Flachmeißel, Hohlmeißel

Chisels
Cinceles
Ciseaux-burins
Scalpelli

Knochenchirurgie

Bone Surgery
Cirugía ósea
Chirurgie osseuse
Chirurgia ossea

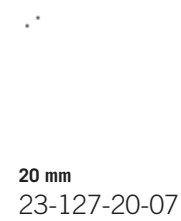
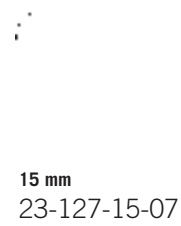
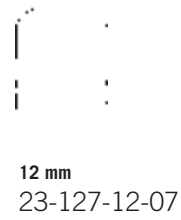
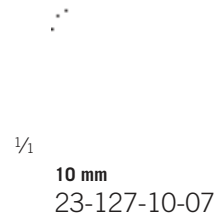
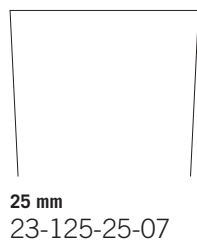
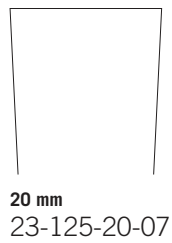
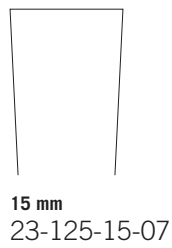
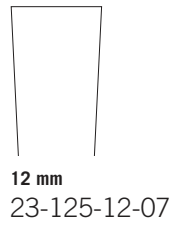
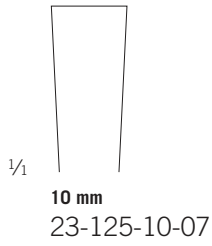
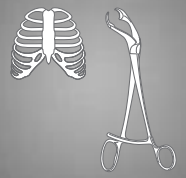

Stille
23-125-10-07 -
23-125-25-07
20,5 cm / 8 1/8"
fein
delicate
fino
fin
fino

Stille
23-127-10-07 -
23-127-25-07
20,5 cm / 8 1/8"

Meißelklingen, Meißelgriff

Chisel Blades, Chisel Handle

Hojas de cincel, Mango para hojas de cincel

Lames-gouges, Manche pour ciseaux-burins

Lame per sgorbie, Manico per scalpello



1/1

Hohlmeißelklingen, auswechselbar
Gouge blades, interchangeable
Hojas de gubia, intercambiables
Lames-gouges, interchangeables
Lame intercambiabili, concavo

r = 50 mm

r = 60 mm

r = 70 mm

1/1

25 mm
23-128-50-07
13,5 cm / 5 3/8"



25 mm
23-128-60-07
13,5 cm / 5 3/8"



25 mm
23-128-70-07
13,5 cm / 5 3/8"

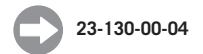

23-128-50-07 -
23-128-70-07

Meißelklingen, auswechselbar
Chisel blades, interchangeable
Hojas de cincel, intercambiables
Lames ciseaux-burin, interchangeables
Lame intercambiabili



1/2

23-130-90-98

Halteschraube
Spare Screw
Tornillo de repuesto
Vis de rechange
Vite di ricambio



5 mm
23-130-05-07
8 cm / 3 1/8"

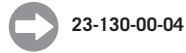

10 mm
23-130-10-07
8 cm / 3 1/8"

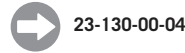

16 mm
23-130-16-07
8 cm / 3 1/8"



25 mm
23-130-25-07
8 cm / 3 1/8"

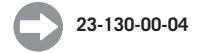

23-130-99-07

Spannschlüssel
Key
Llave
Clé
Chiave



Osteotomklingen, auswechselbar
Osteotome blades, interchangeable
Hojas de osteótomo, intercambiables
Lame per osteotomia, intercambiabili
Lame per osteotomia, intercambiabili

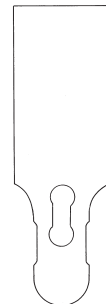
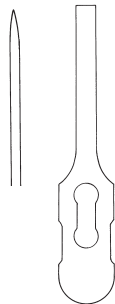

5 mm
23-130-55-07
8 cm / 3 1/8"

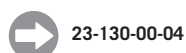

10 mm
23-130-60-07
8 cm / 3 1/8"



16 mm
23-130-66-07
8 cm / 3 1/8"



25 mm
23-130-85-07
8 cm / 3 1/8"



23-130-00-04
18,5 cm / 7 2/8"



Spongiosaentnahmemeißel

Spongiosa Gouges
Cinceles de esponjosa
Ciseaux-burinx pour spongiosa
ScalPELLI per spongiosa

Knochenchirurgie

Bone Surgery
Cirugía ósea
Chirurgie osseuse
Chirurgia ossea

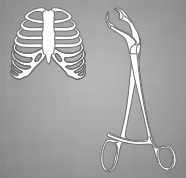

1/4

5 mm
23-131-05-04

1/4

5 mm
23-131-55-04



10 mm
23-131-10-04



10 mm
23-131-60-04

15 mm
23-131-15-04

15 mm
23-131-65-04

1/2

1/2

Lexer
23-131-05-04 -
23-131-15-04
24,5 cm / 9 5/8"

Lexer
23-131-55-04 -
23-131-65-04
24,5 cm / 9 5/8"

Osteotome, Hohlmeißel

Osteotomes, Gouges

Osteótomos, Gubias

Ostéotomes, Gouges

Osteotomi, Sgorbie

Sic

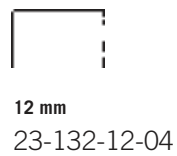
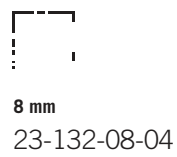
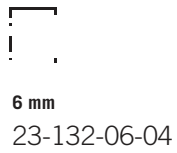
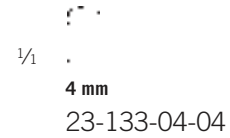
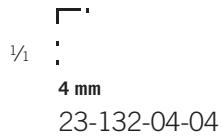

Lexer-Mini
23-132-04-04 -
23-132-12-04
18 cm / 7 1/8"

Lexer-Mini
23-133-04-04 -
23-133-12-04
18 cm / 7 1/8"

Osteotome, Hohlmeißel

Osteotomes, Gouges
 Osteótomos, Gubias
 Ostéotomes, Gouges
 Osteotomi, Sgorbie

Knochenchirurgie

Bone Surgery
 Cirugía ósea
 Chirurgie osseuse
 Chirurgia ossea

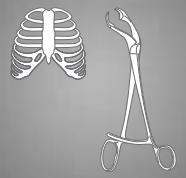

1/1

5 mm
 23-134-05-04

1/1

5 mm
 23-135-05-04



7 mm
 23-134-07-04

10 mm
 23-134-10-04



7 mm
 23-135-07-04

10 mm
 23-135-10-04

15 mm
 23-134-15-04

20 mm
 23-134-20-04

15 mm
 23-135-15-04

20 mm
 23-135-20-04

25 mm
 23-134-25-04

30 mm
 23-134-30-04

25 mm
 23-135-25-04

30 mm
 23-135-30-04

1/2

1/2

Lexer
 23-134-05-04 -
 23-134-30-04
 22 cm / 8 5/8"

Lexer
 23-135-05-04 -
 23-135-30-04
 22 cm / 8 5/8"

Osteotome

Osteotomes

Osteótomos

Ostéotomes

Osteotomi



2 mm

23-136-02-07



3 mm

23-136-03-07



3 mm

23-136-53-07



4 mm

23-136-54-07



4 mm

23-136-04-07



6 mm

23-136-06-07



6 mm

23-136-56-07



8 mm

23-136-58-07



8 mm

23-136-08-07



10 mm

23-136-10-07



10 mm

23-136-60-07



12 mm

23-136-62-07



12 mm

23-136-12-07



15 mm

23-136-15-07

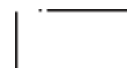

15 mm

23-136-65-07

1/2



Lambotte-Mini
23-136-02-07 -
23-136-15-07
12,5 cm / 4 7/8"

1/2



Lambotte-Mini
23-136-53-07 -
23-136-65-07
17 cm / 6 5/8"

Osteotome

Osteotomes
Osteótomos
Ostéotomes
Osteotomi

Knochenchirurgie

Bone Surgery
Cirugía ósea
Chirurgie osseuse
Chirurgia ossea

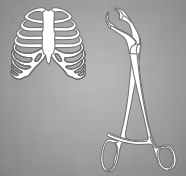

1/4



4 mm

23-138-04-07



6 mm

23-138-06-07



8 mm

23-138-08-07



10 mm

23-138-10-07



13 mm

23-138-13-07



15 mm

23-138-15-07



18 mm

23-138-18-07



20 mm

23-138-20-07



25 mm

23-138-25-07



30 mm

23-138-30-07

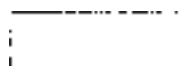

38 mm

23-138-38-07



44 mm

23-138-44-07

50 mm

23-138-50-07

1/2



Lambotte
23-138-04-07 -
23-138-50-07

24 cm / 9 4/8"

Osteotome

Osteotomes
Osteótomos
Ostéotomes
Osteotomi





$\frac{1}{4}$ 
4 mm
23-139-04-07



6 mm
23-139-06-07



8 mm
23-139-08-07



10 mm
23-139-10-07



13 mm
23-139-13-07



15 mm
23-139-15-07



18 mm
23-139-18-07



20 mm
23-139-20-07

25 mm
23-139-25-07

30 mm
23-139-30-07

38 mm
23-139-38-07

44 mm
23-139-44-07

50 mm
23-139-50-07

$\frac{1}{2}$



Lambotte
23-139-04-07 -
23-139-50-07
24 cm / 9 $\frac{1}{8}$ "

Osteotome

Osteotomes
Osteótomos
Ostéotomes
Osteotomi

Knochenchirurgie

Bone Surgery
Cirugía ósea
Chirurgie osseuse
Chirurgia ossea

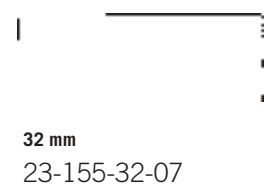
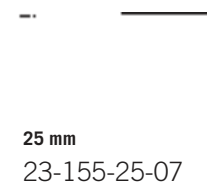
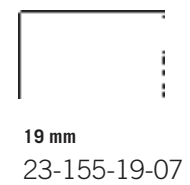
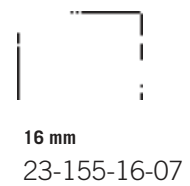
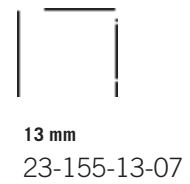
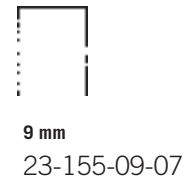
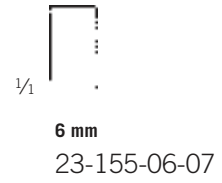
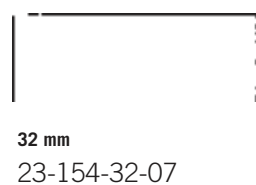
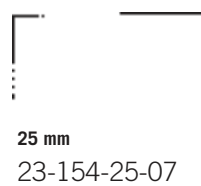
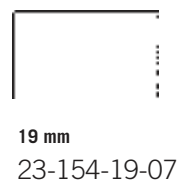
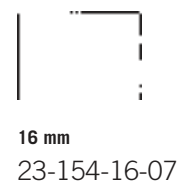
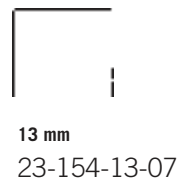
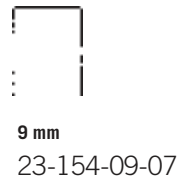
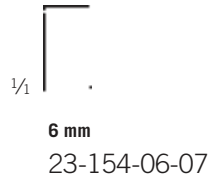
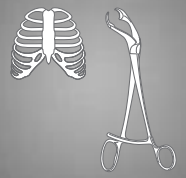

Smith-Petersen
23-154-06-07 -
23-154-32-07
20,5 cm / 8 1/8"

Smith-Petersen
23-155-06-07 -
23-155-32-07
20,5 cm / 8 1/8"

Hohlmeißel

Gouges

Gubias

Gouges

Sgorbie

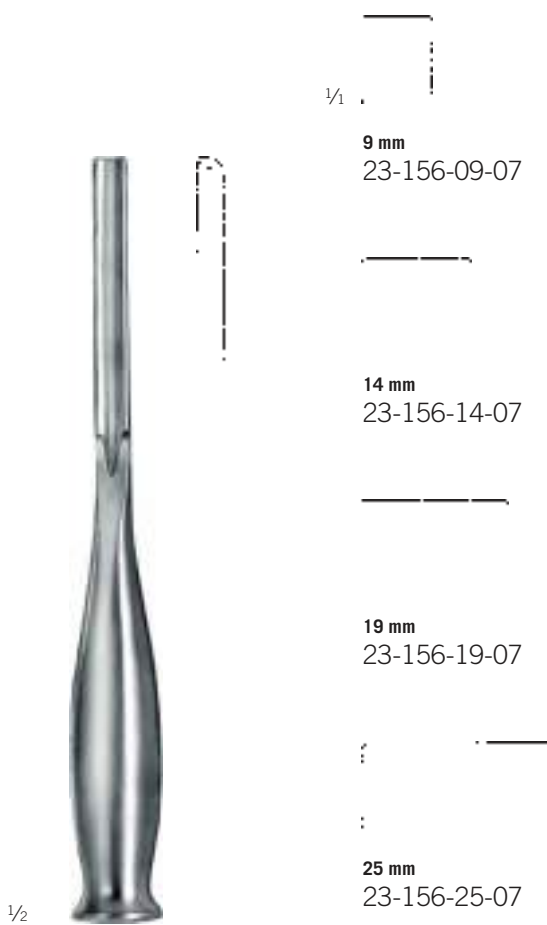

9 mm
23-156-09-07

14 mm
23-156-14-07

19 mm
23-156-19-07

25 mm
23-156-25-07

Smith-Petersen
23-156-09-07 -
23-156-25-07
20,5 cm / 8 1/8"



9 mm
23-157-09-07

14 mm
23-157-14-07

19 mm
23-157-19-07

25 mm
23-157-25-07

Smith-Petersen
23-157-09-07 -
23-157-25-07
20,5 cm / 8 1/8"

Hohlmeißel

Gouges
Gubias
Gouges
Sgorbie

Knochenchirurgie

Bone Surgery
Cirugía ósea
Chirurgie osseuse
Chirurgia ossea

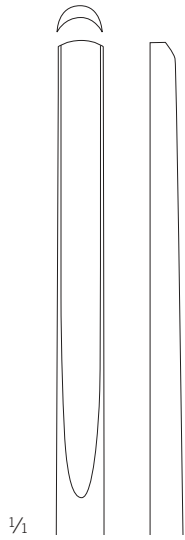
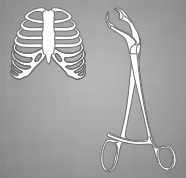

6 mm
23-160-01-04

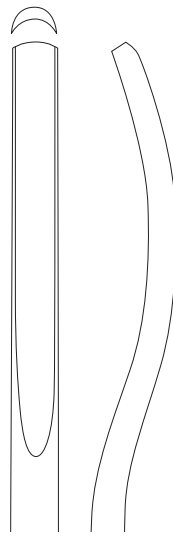

6 mm
23-160-02-04

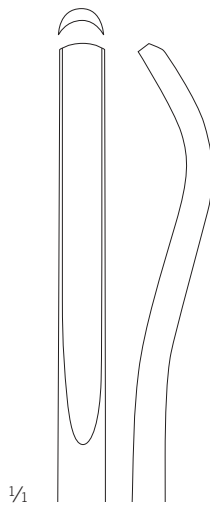

6 mm
23-160-03-04

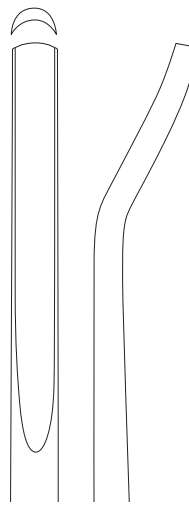

6 mm
23-160-04-04



1/2

Cobb
23-160-01-04 -
23-160-04-04
28 cm / 11"

Osteotome, Flachmeißel

Osteotomes, Chisels
 Osteótomos, Cinceles
 Ostéotomes, Ciseaux-burins
 Osteotomi, Scalpelli

$\frac{1}{2}$	$\frac{1}{1}$	$\frac{1}{1}$	$\frac{1}{1}$
	3 mm 23-162-03-07	6 mm 23-170-06-07	6 mm 23-172-06-07
	5 mm 23-162-05-07	13 mm 23-170-13-07	13 mm 23-172-13-07
	6 mm 23-162-06-07	19 mm 23-170-19-07	19 mm 23-172-19-07
	8 mm 23-162-08-07	25 mm 23-170-25-07	25 mm 23-172-25-07
$\frac{1}{2}$	9 mm 23-162-09-07	32 mm 23-170-32-07	32 mm 23-172-32-07
$\frac{1}{2}$		$\frac{1}{2}$	
Hoke 23-162-03-07 - 23-162-09-07 17 cm / 6 $\frac{5}{8}$ "	Hibbs 23-170-06-07 - 23-170-32-07 24,5 cm / 9 $\frac{5}{8}$ "	Hibbs 23-172-06-07 - 23-172-32-07 24,5 cm / 9 $\frac{5}{8}$ "	

Osteotome, Hohlmeißel

Osteotomes, Gouges
 Osteótomos, Gubias
 Ostéotomes, Gouges
 Osteotomi, Sgorbie

Knochenchirurgie

Bone Surgery
 Cirugía ósea
 Chirurgie osseuse
 Chirurgia ossea

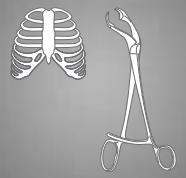

1/1

6 mm
 23-173-06-07



13 mm
 23-173-13-07

19 mm
 23-173-19-07

25 mm
 23-173-25-07

32 mm
 23-173-32-07

1/2

Hibbs
 23-173-06-07 -
 23-173-32-07
 24,5 cm / 9 5/8"

1/1

6 mm
 23-176-06-07



13 mm
 23-176-13-07

19 mm
 23-176-19-07

25 mm
 23-176-25-07

32 mm
 23-176-32-07

1/2

Hibbs
 23-176-06-07 -
 23-176-32-07
 24,5 cm / 9 5/8"

1/1

6 mm
 23-177-06-07



13 mm
 23-177-13-07

19 mm
 23-177-19-07

25 mm
 23-177-25-07

32 mm
 23-177-32-07

1/2

Hibbs
 23-177-06-07 -
 23-177-32-07
 24,5 cm / 9 5/8"

23

Knochenraspeln

Bone Rasps

Escofinas para hueso

Râpes pour os

Raspe per ossa

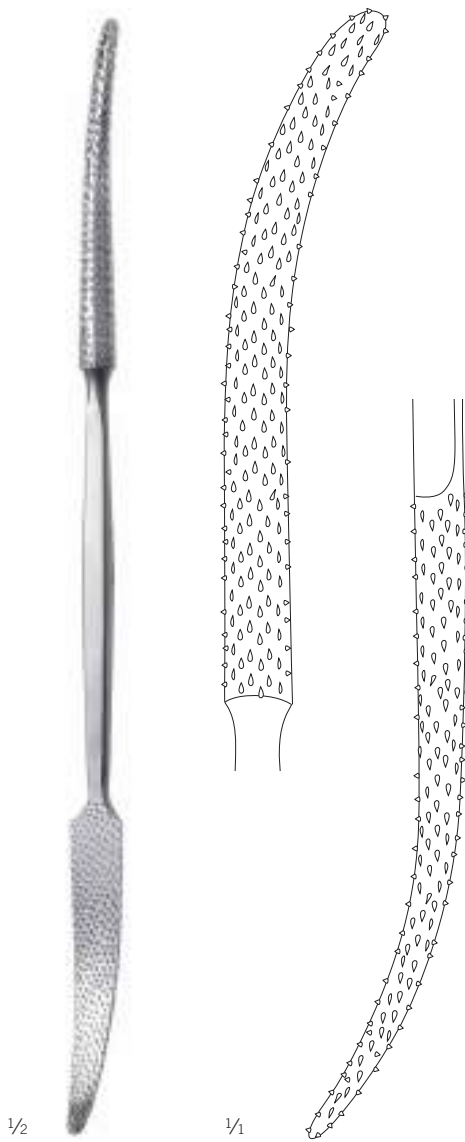

Putti

23-181-30-07

30 cm / 11 ⁶/₈"

rund/halbrund

round / semi round

redonda / semi-redonda

ronde / semi-ronde

rotondo / semi-rotondo

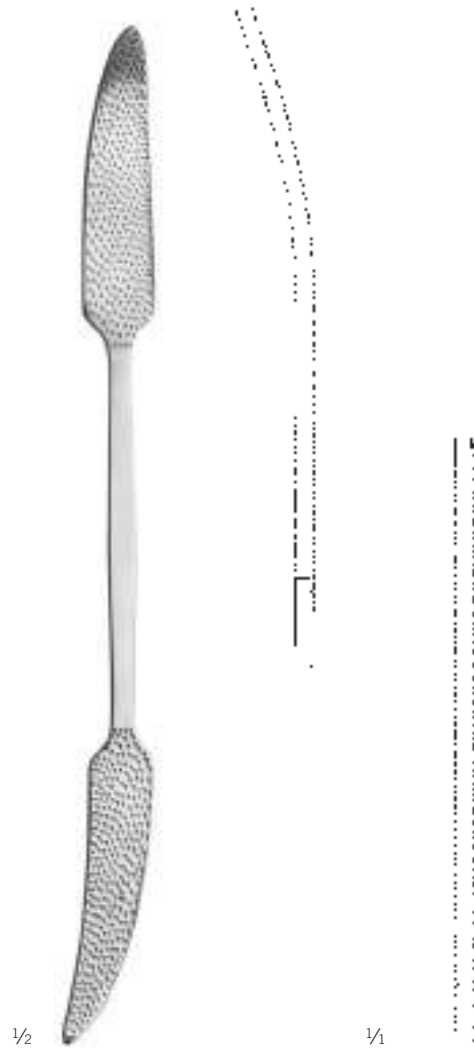

Putti

23-183-27-07

27 cm / 10 ⁵/₈"

gebogen/gerade

curved / straight

curva / recta

courbée / droite

curvo / diritto

Stößel

Tamper
Punzón
Pilon
Pestone

Knochenchirurgie

Bone Surgery
Cirugía ósea
Chirurgie osseuse
Chirurgia ossea

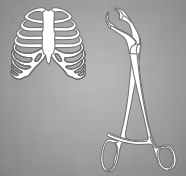

1/1 

Ø 3 mm
23-197-03-04

1/1 

Ø 2 mm
23-198-02-07



Ø 3 mm
23-198-03-07

1/1 

Ø 12 mm
23-199-12-04



Ø 5 mm
23-197-05-04



Ø 4 mm
23-198-04-07



Ø 5 mm
23-198-05-07

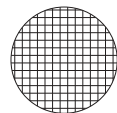

Ø 14 mm
23-199-14-04



Ø 8 mm
23-197-08-04



Ø 6 mm
23-198-06-07



Ø 8 mm
23-198-08-07

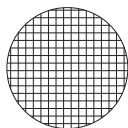

Ø 16 mm
23-199-16-04



Ø 10 mm
23-198-10-07



1/2

Caspar
23-197-03-04 -
23-197-08-04
22 cm / 8 5/8"

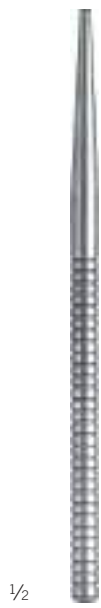

1/2

23-198-02-07 -
23-198-10-07
15,5 cm / 6 1/8"



1/2

23-199-12-04 -
23-199-16-04
20 cm / 8"



Hämmer

Mallets

Martillos

Maillets

Martelli

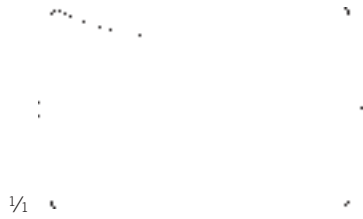

23-200-01-07

24 cm / 9 4/8"

Gewicht	Kopf
weight	head
peso	cabeza
poids	tête
peso	testa

275 g **Ø 26 mm**

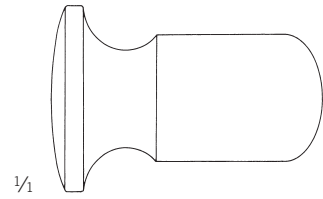

23-204-01-07

20,5 cm / 8 1/8"

Gewicht	Kopf
weight	head
peso	cabeza
poids	tête
peso	testa

120 g **Ø 25 mm**



23-200-02-07

24 cm / 9 4/8"

Gewicht	Kopf
weight	head
peso	cabeza
poids	tête
peso	testa

320 g **Ø 28 mm**

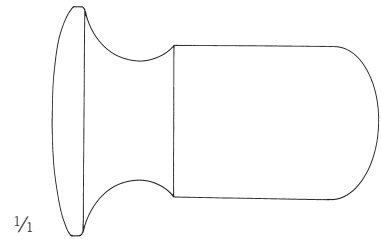

23-204-02-07

21 cm / 8 2/8"

Gewicht	Kopf
weight	head
peso	cabeza
poids	tête
peso	testa

170 g **Ø 30 mm**



23-200-03-07

24 cm / 9 4/8"

Gewicht	Kopf
weight	head
peso	cabeza
poids	tête
peso	testa

340 g **Ø 30 mm**

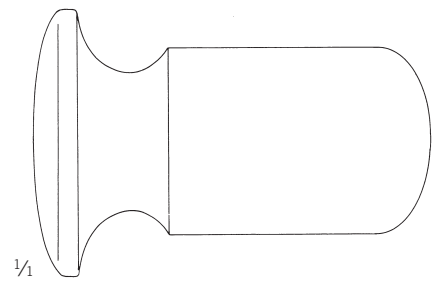

23-204-03-07

21,5 cm / 8 4/8"

Gewicht	Kopf
weight	head
peso	cabeza
poids	tête
peso	testa

260 g **Ø 35 mm**

1/2

1/2

Williger
23-200-01-07 -
23-200-03-07

bleigefüllt
lead filled
relleno de plomo
remplissage de plomb
ripieno di piombo

Doyen
23-204-01-07 -
23-204-03-07

Hämmer

Mallets
Martillos
Maillets
Martelli

Knochenchirurgie

Bone Surgery
Cirugía ósea
Chirurgie osseuse
Chirurgia ossea

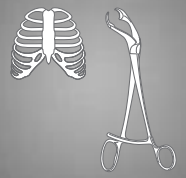

23-214-01-07

Kopf	Gewicht
head	weight
cabeza	peso
tête	poids
testa	peso
Ø 19 mm	230 g

Gewicht	Kopf
weight	head
peso	cabeza
poids	tête
peso	testa
220 g	Ø 30 mm

Kopf	Gewicht
head	weight
cabeza	peso
tête	poids
testa	peso
Ø 30 mm	300 g



1/2

Collin
23-208-20-07
20 cm / 7 7/8"



1/2

Lucae
23-214-01-07 -
23-214-02-07
19,5 cm / 7 5/8"



23-214-02-07

Kopf	Gewicht
head	weight
cabeza	peso
tête	poids
testa	peso
Ø 25 mm	260 g



1/2

Cottle
23-215-19-07
19 cm / 7 4/8"
plan/konvex
plane / convex
plano / convexo
plan / convexe
plano / convesso

Hämmer

Mallets
Martillos
Maillets
Martelli



1/1

23-221-00-04

Ersatzbacken (Paar)
Spare Facings (pair)
Tapas de repuesto (par)
Plaques de rechange (paire)
Placche di ricambio (paio)



23-220-17-02



1/2

Williger

23-216-01-07

16,5 cm / 6 4/8"

Kopf	Gewicht
head	weight
cabeza	peso
tête	poids
testa	peso
Ø 20 mm	140 g



1/2

23-218-22-07

26 cm / 10 2/8"



Kopf	Gewicht
head	weight
cabeza	peso
tête	poids
testa	peso
Ø 30 mm	450 g



1/2

Mead

23-220-17-02

19 cm / 7 4/8"

mit austauschbaren Kunststoffbacken
with interchangeable plastic disks
con tapas intercambiables
avec plaques interchangeables
con placche intercambiabili

Kopf	Gewicht
head	weight
cabeza	peso
tête	poids
testa	peso
Ø 27 mm	330 g



1/2

Partsch

23-224-18-07

19 cm / 7 4/8"

mit Hohlheft
with hollow handle
con mango hueco
avec manche creux
con manico vuoto

Kopf	Gewicht
head	weight
cabeza	peso
tête	poids
testa	peso
Ø 27 mm	175 g

Hämmer

Mallets
Martillos
Maillets
Martelli

Knochenchirurgie

Bone Surgery
Cirugía ósea
Chirurgie osseuse
Chirurgia ossea

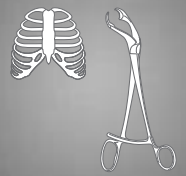

1/2

23-236-01-04

26 cm / 10 2/8"

mit Bleifüllung
with lead filling
con relleno de plomo
remplissage de plomb
ripieno di piombo

Fz

Kopf	Gewicht
head	weight
cabeza	peso
tête	poids
testa	peso
Ø 45 mm	340 g



1/2

23-236-02-04

26 cm / 10 2/8"

ohne Bleifüllung
without lead filling
sin relleno de plomo
sans remplissage de plomb
senza ripieno di piombo

Fz

Kopf	Gewicht
head	weight
cabeza	peso
tête	poids
testa	peso
Ø 45 mm	240 g



1/2

23-240-91-98

Ersatzbacke
Spare facing
Tapa de repuesto
Placque de rechange
Placche di ricambio

Ny



23-240-29-07

23-240-29-07

26,5 cm / 10 3/8"

plan (Kunststoff), konvex (Stahl),
plane (nylon), convex (steel),
plano (nilón), convexo (acero),
plan (nylon), convexe (acier),
plano (nilon), convesso (acciaio),

Fz

Kopf	Gewicht
head	weight
cabeza	peso
tête	poids
testa	peso
Ø 32 mm	620 g

Hämmer

Mallets
Martillos
Maillets
Martelli



1/2

23-242-24-07

26 cm / 10 2/8"



Kopf
head
cabeza
tête
testa

Ø 32 mm

Gewicht
weight
peso
poids
peso
610 g



1/2

23-244-24-07

24 cm / 9 4/8"



Kopf
head
cabeza
tête
testa

Ø 30 mm

Gewicht
weight
peso
poids
peso
460 g



Fz



23-254-22-07



1/2

23-254-22-07

24 cm / 9 4/8"



Kopf
head
cabeza
tête
testa

Ø 37 mm

Gewicht
weight
peso
poids
peso
345 g

23-255-00-04

Ersatzbacken (Paar)
Spare Facings (pair)
Tapas de repuesto (par)
Plaques de rechange (paire)
Placche di ricambio (paio)

Hämmer

Mallets
Martillos
Maillets
Martelli

Knochenchirurgie

Bone Surgery
Cirugía ósea
Chirurgie osseuse
Chirurgia ossea

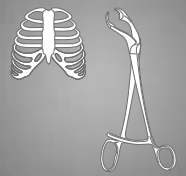

1/2

23-256-18-04
22 cm / 8 5/8"

Fz

Kopf	Gewicht
head	weight
cabeza	peso
tête	poids
testa	peso
Ø 30 mm	135 g



1/2

23-260-01-07
26,5 cm / 10 3/8"

Fz

Kopf	Gewicht
head	weight
cabeza	peso
tête	poids
testa	peso
Ø 30 mm	580 g



1/2

23-260-02-07
26,5 cm / 10 3/8"

Fz

Kopf	Gewicht
head	weight
cabeza	peso
tête	poids
testa	peso
Ø 50 mm	1300 g

Scharfe Löffel

Bone Currettes
Cucharillas cortantes
Currettes tranchantes
Curette taglienti



1/1

Fig. 0000
23-280-40-04

Fig. 000
23-280-30-04

1/1

Fig. 0
23-282-10-04

Fig. 1
23-282-01-04

Fig. 00
23-280-20-04

Fig. 0
23-280-10-04

Fig. 2
23-282-02-04

Fig. 3
23-282-03-04

Fig. 1
23-280-01-04

Fig. 2
23-280-02-04

Fig. 4
23-282-04-04

Fig. 3
23-280-03-04

Fig. 4
23-280-04-04

Fig. 5
23-280-05-04

Fig. 6
23-280-06-04



1/2

Volkman
23-280-01-04 -
23-280-40-04

17 cm / 6 5/8"
oval
oval
ovalada
ovale
ovala



1/2

Volkman
23-282-01-04 -
23-282-10-04

27 cm / 10 5/8"
oval
oval
ovalada
ovale
ovala

Scharfe Löffel

Bone Currettes
Cucharillas cortantes
Currettes tranchantes
Curette taglienti

Knochenchirurgie

Bone Surgery
Cirugía ósea
Chirurgie osseuse
Chirurgia ossea

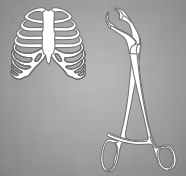

1/1



Fig. 000
23-300-30-07



Fig. 00
23-300-20-07

1/1



Fig. 0000
23-304-40-07



Fig. 000
23-304-30-07

1/1



Fig. 0000
23-306-40-07



Fig. 0
23-300-10-07



Fig. 1
23-301-01-07



Fig. 00
23-304-20-07



Fig. 0
23-304-10-07



Fig. 000
23-306-30-07



Fig. 2
23-301-02-07



Fig. 3
23-301-03-07



Fig. 1
23-305-01-07



Fig. 2
23-305-02-07



Fig. 00
23-306-20-07



Fig. 4
23-301-04-07



Fig. 3
23-305-03-07



Fig. 4
23-305-04-07



Fig. 0
23-306-10-07



Fig. 5
23-305-05-07



Fig. 6
23-305-06-07

1/2



Schede
23-300-10-07 -
23-301-04-07

17 cm / 6 5/8"
oval, mit Hohlheft
oval, with hollow handle
ovalada, con mango hueco
ovale, avec manche creux
ovala, con manico vuoto

1/2



Volkmann
23-304-10-07 -
23-305-06-07

17 cm / 6 5/8"
oval, mit Hohlheft
oval, with hollow handle
ovalada, con mango hueco
ovale, avec manche creux
ovala, con manico vuoto

1/2



Daubenspeck
23-306-10-07 -
23-306-40-07

17 cm / 6 5/8"
oval, mit Hohlheft
oval, with hollow handle
ovalada, con mango hueco
ovale, avec manche creux
ovale, con manico vuoto

Scharfe Löffel

Bone Currettes

Cucharillas cortantes

Currettes tranchantes

Curette taglienti

1/1

Fig. 0000

23-308-40-07

Fig. 000

23-308-30-07

1/1

Fig. 0000

23-312-40-07

Fig. 000

23-312-30-07

Fig. 00

23-308-20-07

Fig. 0

23-308-10-07

Fig. 00

23-312-20-07

Fig. 0

23-312-10-07

Fig. 1

23-309-01-07

Fig. 2

23-309-02-07

Fig. 1

23-313-01-07

Fig. 2

23-313-02-07

Fig. 3

23-309-03-07

Fig. 4

23-309-04-07

Fig. 3

23-313-03-07

Fig. 4

23-313-04-07

Fig. 5

23-309-05-07

Fig. 6

23-309-06-07

Fig. 5

23-313-05-07



1/2

Bruns
23-308-10-07 -
23-309-06-07

17 cm / 6 5/8"

rund, mit Hohlheft
round, with hollow handle
redonda, con mango hueco
rond, avec manche creux
rotonda, con manico vuoto



1/2

Spratt
23-312-10-07 -
23-313-05-07

17 cm / 6 5/8"

oval, mit Hohlheft
oval, with hollow handle
ovalada, con mango hueco
ovale, avec manche creux
ovalada, con manico vuoto

Scharfe Löffel

Bone Currettes
Cucharillas cortantes
Currettes tranchantes
Curette taglienti

Knochenchirurgie

Bone Surgery
Cirugía ósea
Chirurgie osseuse
Chirurgia ossea

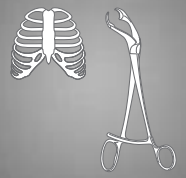

Fig. 000
23-334-30-07



Fig. 00
23-334-20-07



23-336-25-07



Fig. 1
23-340-01-07



Fig. 0
23-334-10-07



Fig. 1
23-335-01-07

23-337-25-07

Fig. 2
23-340-02-07



Fig. 2
23-335-02-07



Fig. 3
23-335-03-07

23-339-25-07

Fig. 3
23-340-03-07



Fig. 4
23-335-04-07



Fig. 5
23-335-05-07

Fig. 4
23-340-04-07



Fig. 6
23-335-06-07

Fig. 5
23-340-05-07

Fig. 6
23-340-06-07



1/2

Bruns
23-334-10-07 -
23-335-06-07

23 cm / 9"
oval, massiv
oval, solid
ovalada, maciza
ovale, solide
ovala, solida



1/2

Scoville
23-336-25-07 -
23-339-25-07

25 cm / 9 7/8"
oval, mit Hohlheft
oval, with hollow handle
ovalada, con mango hueco
ovale, avec manche creux
ovala, con manico vuoto



1/2

Simon
23-340-01-07 -
23-340-06-07

22,5 cm / 8 7/8"
oval, mit Hohlheft
oval, with hollow handle
ovalada, con mango hueco
ovale, avec manche creux
ovala, con manico vuoto

Scharfe Löffel

Bone Curettes
Cucharillas cortantes
Curettes tranchantes
Curette taglienti

1/1 ○

Fig. 000
23-342-30-07

1/1 ' ○

Fig. 1
23-344-01-07

1/1 ○

Fig. 1
23-345-01-07

○

Fig. 00
23-342-20-07

Fig. 2
23-344-02-07

Fig. 2
23-345-02-07

○

Fig. 0
23-342-10-07

⋮

Fig. 3
23-344-03-07

⋮

Fig. 3
23-345-03-07

○

Fig. 1
23-342-01-07

⋮

Fig. 4
23-344-04-07

⋮

Fig. 4
23-345-04-07

⋮

Fig. 5
23-344-05-07

⋮

Fig. 5
23-345-05-07

⋮

Fig. 6
23-344-06-07

⋮

Fig. 6
23-345-06-07



1/2



1/2



1/2

23-342-01-07 -
23-342-30-07
25 cm / 9 7/8"

oval, mit Hohlheft
oval, with hollow handle
ovalada, con mango hueco
ovale, avec manche creux
ovalada, con manico vuoto

Modell USA
23-344-01-07 -
23-344-06-07
16,5 cm / 6 4/8"

oval, mit Hohlheft
oval, with hollow handle
ovalada, con mango hueco
ovale, avec manche creux
ovalada, con manico vuoto

Modell USA
23-345-01-07 -
23-345-06-07
16 cm / 6 2/8"

oval, mit Hohlheft
oval, with hollow handle
ovalada, con mango hueco
ovale, avec manche creux
ovalada, con manico vuoto

Scharfe Löffel

Bone Currettes
Cucharillas cortantes
Currettes tranchantes
Curette taglianti

Knochenchirurgie

Bone Surgery
Cirugía ósea
Chirurgie osseuse
Chirurgia ossea

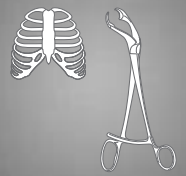

1/1

Fig. 1
23-347-01-07

1/1 ○

3 mm
23-348-03-07

1/1

Fig. 1
23-350-01-07

Fig. 2
23-347-02-07

○

4 mm
23-348-04-07

Fig. 2
23-350-02-07

⋮

Fig. 3
23-347-03-07

○

5 mm
23-348-05-07

Fig. 3
23-350-03-07

Fig. 4
23-347-04-07



Fig. 5
23-347-05-07



Fig. 6
23-347-06-07



1/2

1/2

1/2

Modell USA
23-347-01-07 -
23-347-06-07

16,5 cm / 6 4/8"
oval, mit Hohlheft
oval, with hollow handle
ovalada, con mango hueco
ovale, avec manche creux
ovala, con manico vuoto

Bushe
23-348-03-07 -
23-348-05-07

25 cm / 9 7/8"
oval, mit Hohlheft
oval, with hollow handle
ovalada, con mango hueco
ovale, avec manche creux
ovala, con manico vuoto

Halle
23-350-01-07 -
23-350-03-07

21 cm / 8 2/8"
oval, biegsamer Schaft, mit Hohlheft
oval, malleable shaft, with hollow handle
ovalada, vástago maleable, con mango hueco
ovale, tige malléable, avec manche creux
ovala, gambo malleable, con manico vuoto

Scharfe Löffel

Bone Curettes

Cucharillas cortantes

Curettes tranchantes

Curette taglienti



Jacobsen
23-351-14-07
14 cm / 5 4/8"



Volkman
23-352-13-07 -
23-352-17-07

23-352-13-07
12,5 cm / 4 7/8"

23-352-14-07
14,5 cm / 5 6/8"

23-352-17-07
17 cm / 6 6/8"



Volkman
23-354-13-07 -
23-354-20-07

23-354-13-07
13 cm / 5 1/8"

23-354-16-07
16 cm / 6 2/8"

23-354-20-07
20 cm / 7 7/8"



23-356-21-07
21 cm / 8 2/8"

Scharfe Doppellöffel, Scharfe Küretten

Bone Curettes, double-ended, Bone Curettes
 Cucharillas de doble extremo, Curetas cortantes
 Curettes doubles, Curettes
 Curette doppie, Curette

Knochenchirurgie

Bone Surgery
 Cirugía ósea
 Chirurgie osseuse
 Chirurgia ossea

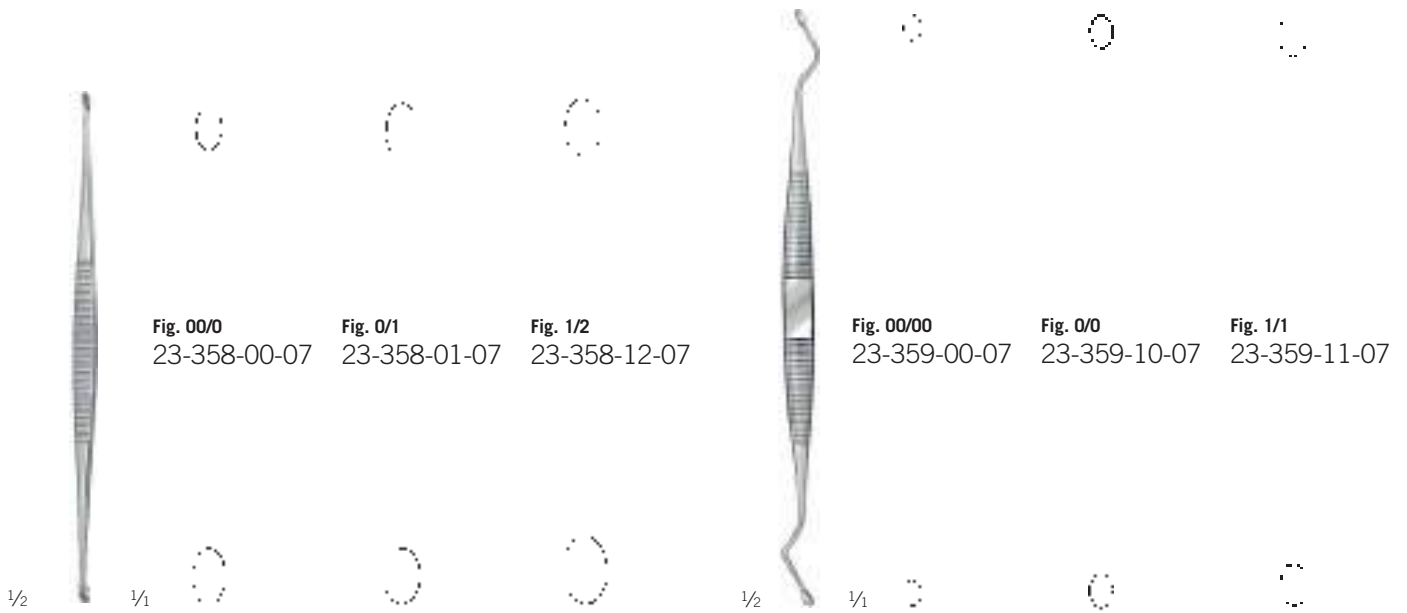
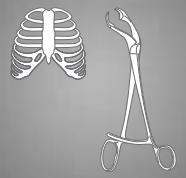

Fig. 00/0
23-358-00-07

Fig. 0/1
23-358-01-07

Fig. 1/2
23-358-12-07

Fig. 00/00
23-359-00-07

Fig. 0/0
23-359-10-07

Fig. 1/1
23-359-11-07

Williger
 23-358-00-07 -
 23-358-12-07
 14 cm / 5 4/8"
 oval
 oval
 ovalada
 ovale
 ovale

Williger
 23-359-00-07 -
 23-359-11-07
 16,5 cm / 6 4/8"
 oval
 oval
 ovalada
 ovale
 ovale

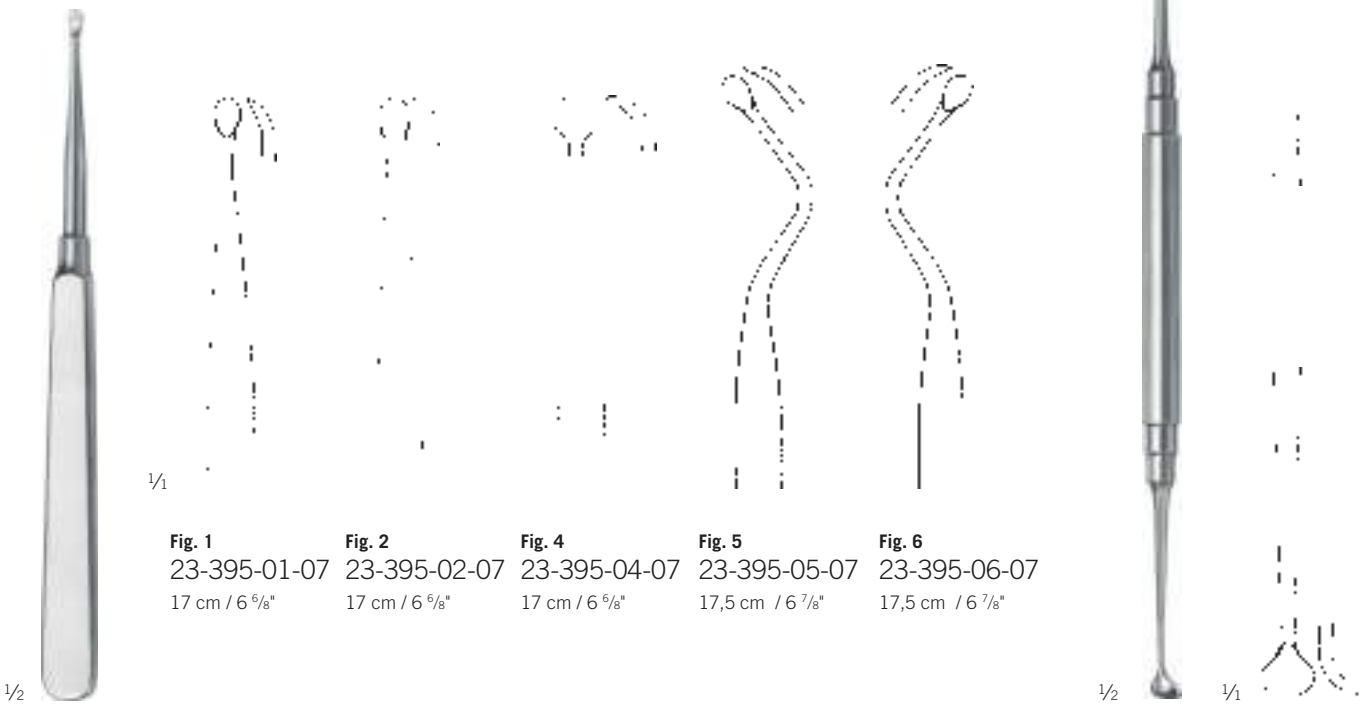

Fig. 1
23-395-01-07
17 cm / 6 5/8"

Fig. 2
23-395-02-07
17 cm / 6 5/8"

Fig. 4
23-395-04-07
17 cm / 6 5/8"

Fig. 5
23-395-05-07
17,5 cm / 6 7/8"

Fig. 6
23-395-06-07
17,5 cm / 6 7/8"

Molt
 23-395-01-07 -
 23-395-06-07

Molt
 23-395-24-07
 19 cm / 7 4/8"

Raspatorien

Periosteal Elevators

Periostótomos

Rugines-raspatoires

Periostotomi

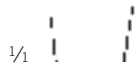

16 mm
23-400-01-07
19 cm / 7 4/8"



16 mm
23-400-02-07
20 cm / 7 7/8"



7 mm
23-400-10-07
16 cm / 6 2/8"



15 mm
23-400-11-07
18,5 cm / 7 2/8"



12 mm
23-400-03-07
19 cm / 7 4/8"

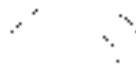

12 mm
23-400-04-07
18 cm / 7 1/8"



20 mm
23-400-12-07
19 cm / 7 4/8"



1/2

Martin-Langenbeck
23-400-01-07 -
23-400-04-07

massiv
solid
macizo
solide
pieno



1/2

Martin-Hoen
23-400-10-07 -
23-400-12-07

massiv
solid
macizo
solide
pieno

Raspatorien

Periosteal Elevators
 Periostótomos
 Rugines-raspatoires
 Periostotomi

Knochenchirurgie

Bone Surgery
 Cirugía ósea
 Chirurgie osseuse
 Chirurgia ossea

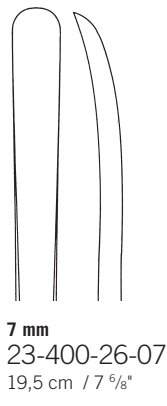
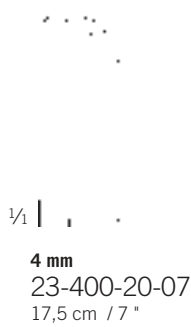
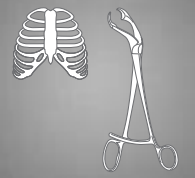

Martin-Cushing
 23-400-20-07 -
 23-400-26-07

massiv
 solid
 macizo
 solide
 pieno

Martin-Cushing
 23-400-30-07
 17 cm / 6 6/8"

massiv
 solid
 macizo
 solide
 pieno

Raspatorien

Periosteal Elevators

Periostótomos

Rugines-raspatoires

Periostotomi



Langenbeck
23-401-18-07
18 cm / 7 1/8"
mit Hohlheft
with hollow handle
con mango hueco
avec manche creux
con manico vuoto



Langenbeck
23-402-19-07
19 cm / 7 4/8"
mit Hohlheft
with hollow handle
con mango hueco
avec manche creux
con manico vuoto



Landolt
23-404-18-07
17,5 cm / 6 7/8"

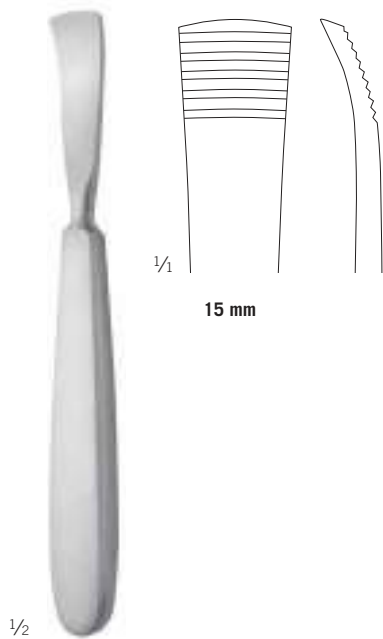

Jansen
23-405-17-07
16,5 cm / 6 4/8"

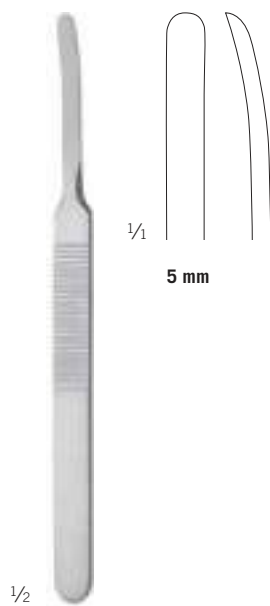

König
23-406-16-07
15,5 cm / 6 1/8"

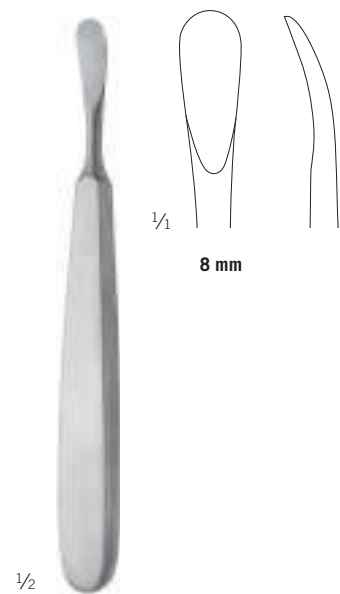

Trelat
23-407-15-07
15 cm / 5 7/8"

Raspatorien

Periosteal Elevators
 Periostótomos
 Rugines-raspatoires
 Periostotomi

Knochenchirurgie

Bone Surgery
 Cirugía ósea
 Chirurgie osseuse
 Chirurgia ossea

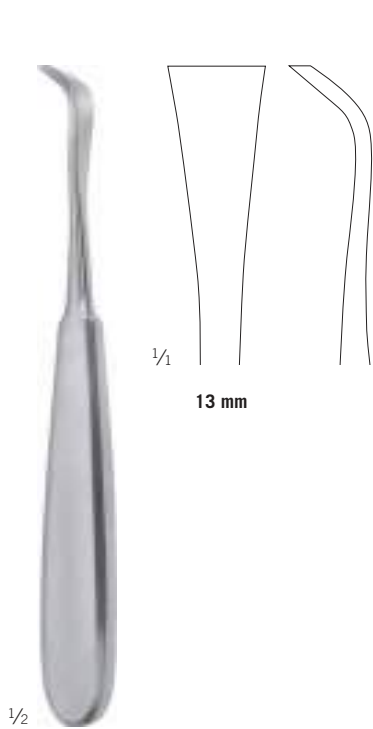
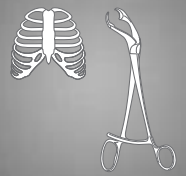

Schneider
 23-408-18-07
 17,5 cm / 6 7/8"

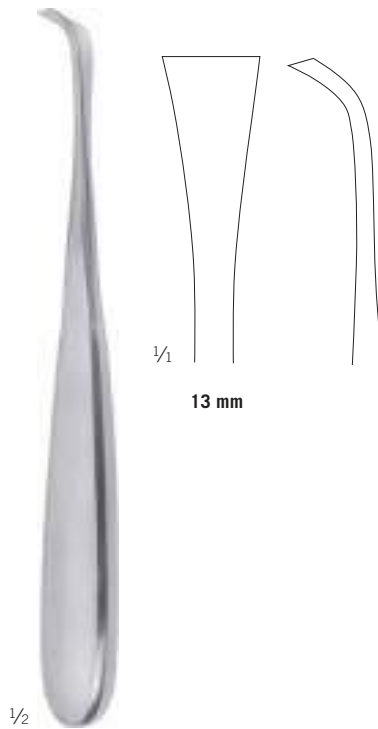

Schneider-Sauerbruch
 23-409-14-07
 19 cm / 7 4/8"

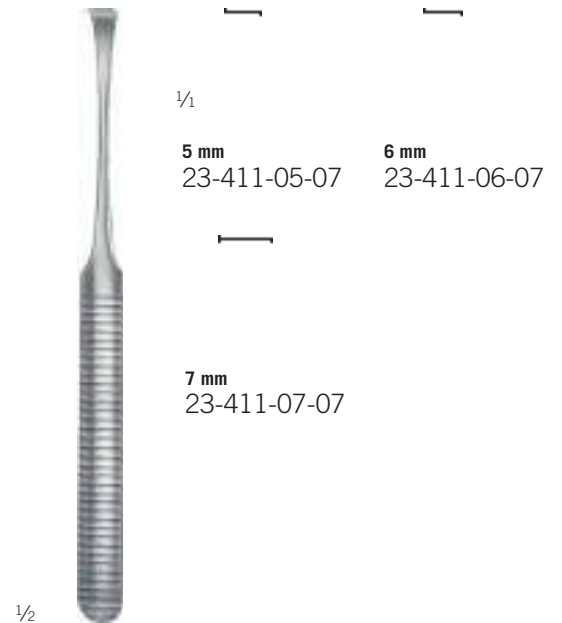

23-411-05-07 -
 23-411-07-07
 16 cm / 6 2/8"

fein, gewinkelt, massiv
 delicate, angled, solid
 fino, angulada, macizo
 fin, coudée, solide
 fino, angulata, solido

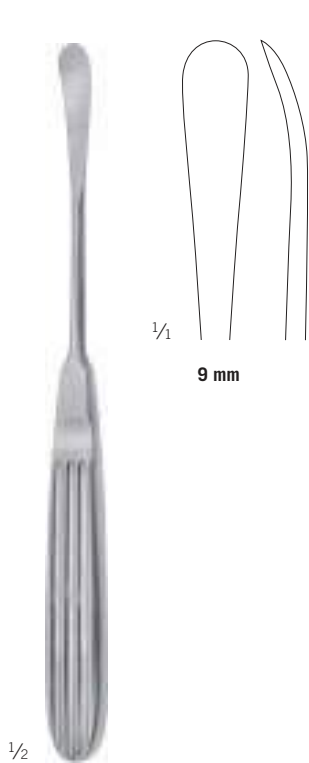

Cottle
 23-412-20-07
 19 cm / 7 4/8"



Sewall
 23-413-20-07
 20 cm / 7 7/8"

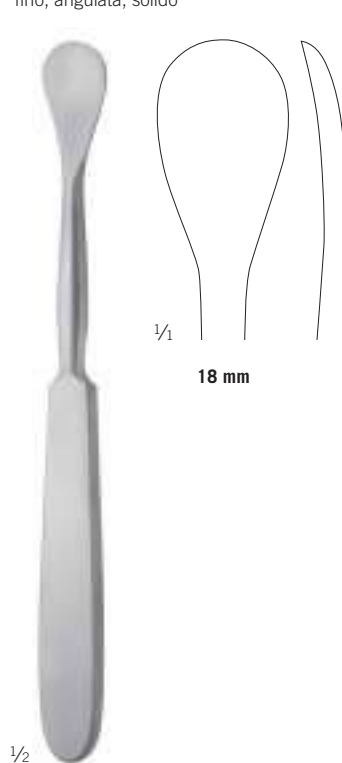

Sedillot
 23-414-19-07
 18,5 cm / 7 2/8"

Raspatorien

Periosteal Elevators

Periostótomos

Rugines-raspatoires

Periostotomi

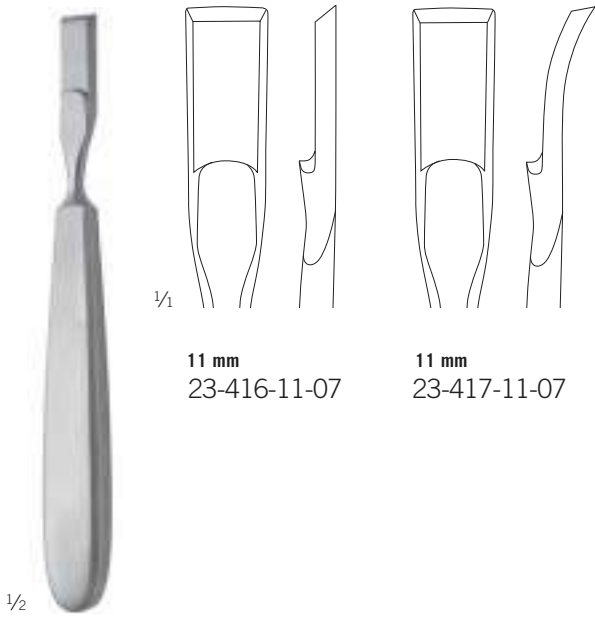

11 mm
23-416-11-07

11 mm
23-417-11-07

Farabeuf-Collin
23-416-11-07 -
23-417-11-07
15,5 cm / 6 1/8"

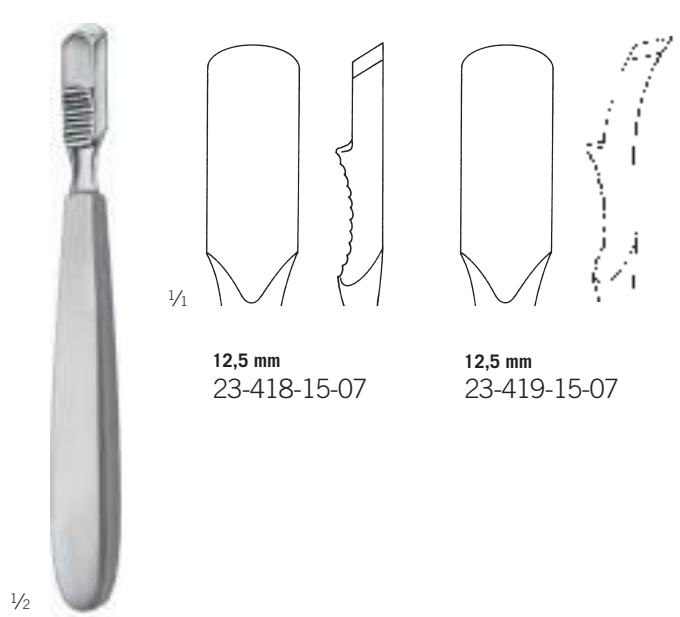

12,5 mm
23-418-15-07

12,5 mm
23-419-15-07

Farabeuf
23-418-15-07 -
23-419-15-07
15,5 cm / 6 1/8"
mit Hohlheft
with hollow handle
con mango hueco
avec manche creux
con manico vuoto

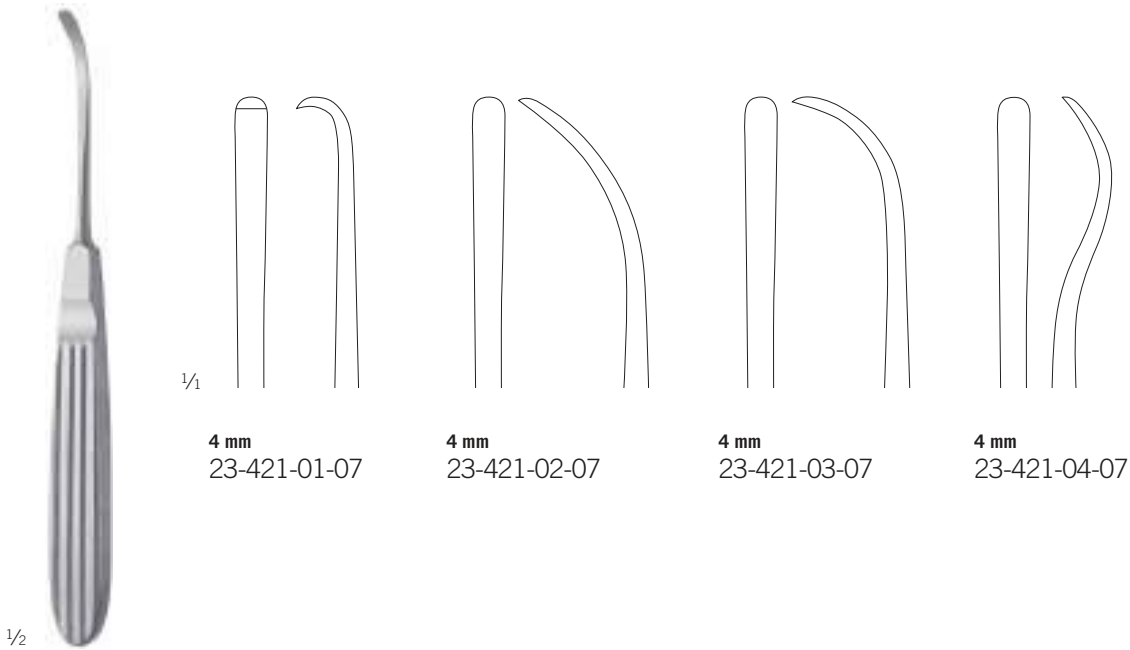

4 mm
23-421-01-07

4 mm
23-421-02-07

4 mm
23-421-03-07

4 mm
23-421-04-07

Mühling
23-421-01-07 -
23-421-04-07
17 cm / 6 5/8"

Raspatorien

Periosteal Elevators
 Periostótomos
 Rugines-raspatoires
 Periostotomi

Knochenchirurgie

Bone Surgery
 Cirugía ósea
 Chirurgie osseuse
 Chirurgia ossea

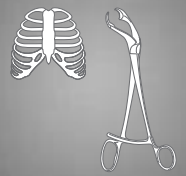

1/4

3 mm
 23-423-06-07
 18 cm / 7 1/8"



6,5 mm
 23-423-01-07
 18 cm / 7 1/8"

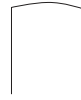

9,5 mm
 23-423-02-07
 19 cm / 7 4/8"

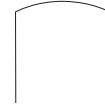

12,5 mm
 23-423-03-07
 19 cm / 7 4/8"

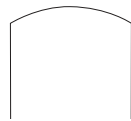

16 mm
 23-423-07-07
 20 cm / 7 7/8"



19 mm
 23-423-04-07
 20 cm / 7 7/8"

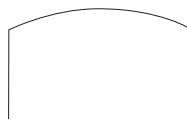

24,5 mm
 23-423-05-07
 21 cm / 8 2/8"

1/2

Key
 23-423-01-07 -
 23-423-05-07



1/4

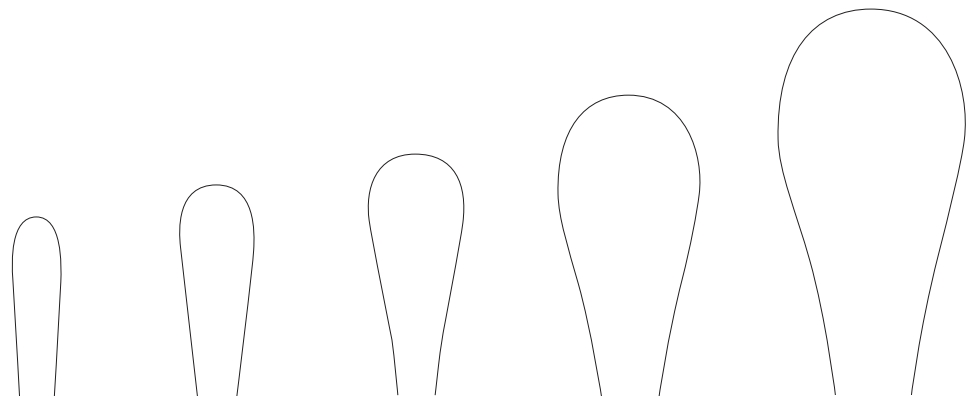

	6 mm	10 mm	13 mm	19 mm	25 mm
23 cm / 9"	23-426-06-07	23-426-10-07	23-426-13-07	23-426-19-07	23-426-25-07
28 cm / 11"	23-425-06-07	23-425-10-07	23-425-13-07	23-425-19-07	23-425-25-07

Cobb
 23-425-06-07 -
 23-426-25-07

1/2

Raspatorien

Periosteal Elevators

Periostótomos

Rugines-raspatoires

Periostotomi

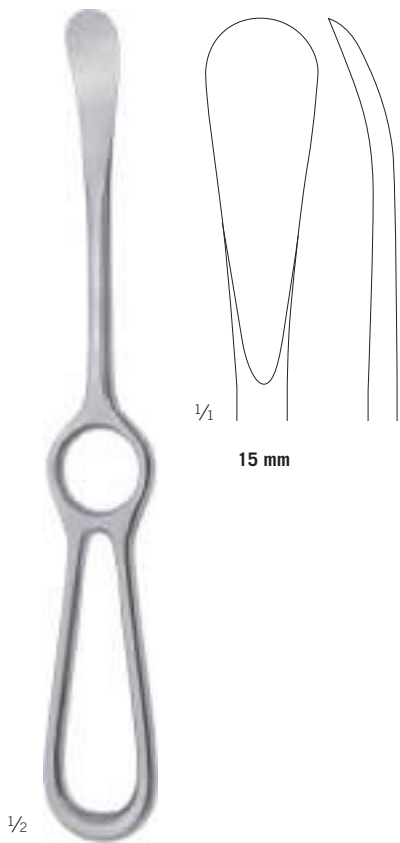

15 mm

1/2

Sedillot
23-427-21-07
23 cm / 9"



6 mm

1/2

23-428-06-04
20 cm / 7 7/8"



14 mm

1/2

23-429-14-04
20 cm / 7 7/8"

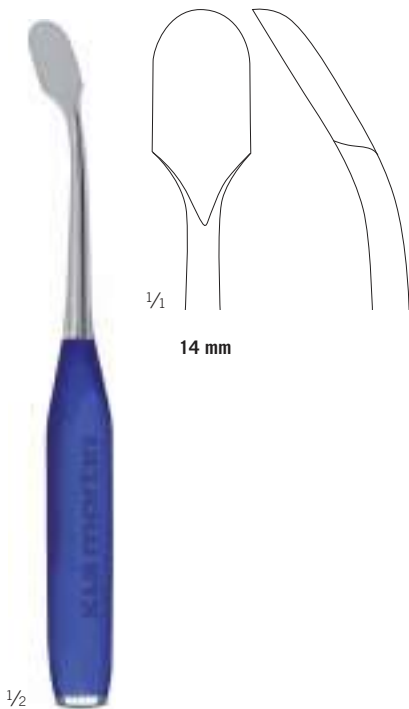

14 mm

1/2

23-432-14-04
20 cm / 7 7/8"



6 mm

1/2

23-432-18-04
20 cm / 7 7/8"



3 mm

1/2

23-433-03-04
20 cm / 7 7/8"



Raspatorien

Periosteal Elevators
 Periostótomos
 Rugines-raspatoires
 Periostotomi

Knochenchirurgie

Bone Surgery
 Cirugía ósea
 Chirurgie osseuse
 Chirurgia ossea

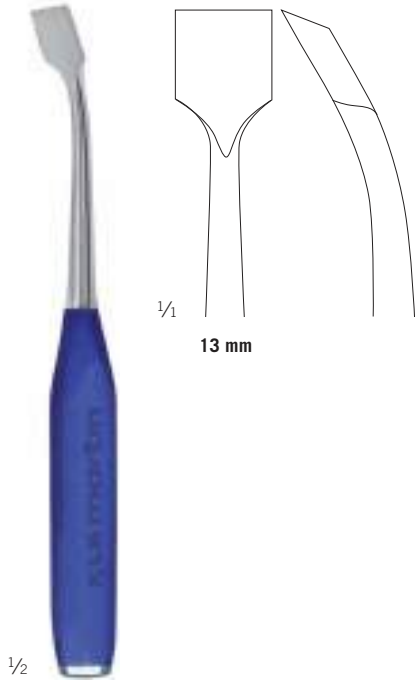
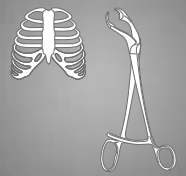

23-433-13-04
 20 cm / 7 7/8"



23-433-18-04
 20 cm / 7 7/8"

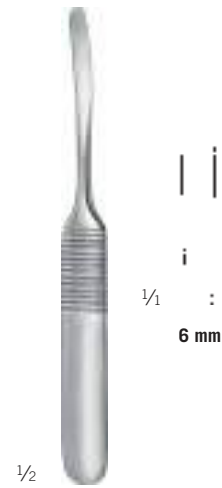

Williger
 23-434-13-07
 12,5 cm / 4 7/8"
 massiv
 solid
 macizo
 solide
 pieno

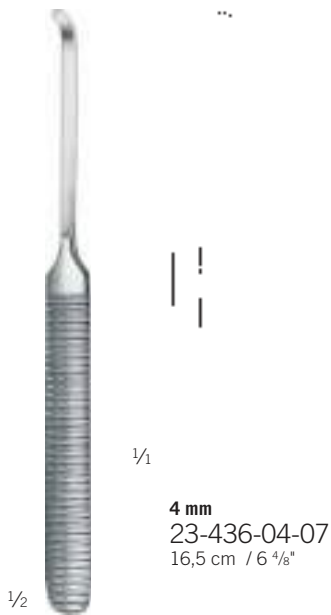

Kahre-Williger
 23-436-04-07 -
 23-436-05-07
 16,5 cm / 6 4/8"
 massiv
 solid
 macizo
 solide
 pieno



5 mm
 23-436-05-07
 16,5 cm / 6 4/8"

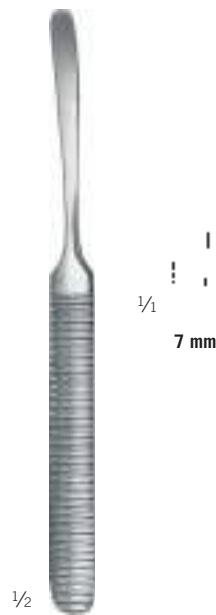

Williger
 23-436-07-07
 16 cm / 6 4/8"
 massiv
 solid
 macizo
 solide
 pieno

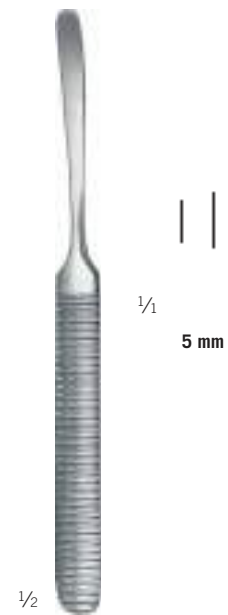

Williger
 23-436-16-07
 16 cm / 6 4/8"
 massiv
 solid
 macizo
 solide
 pieno

Raspatorien

Periosteal Elevators

Periostótomos

Rugines-raspatoires

Periostotomi

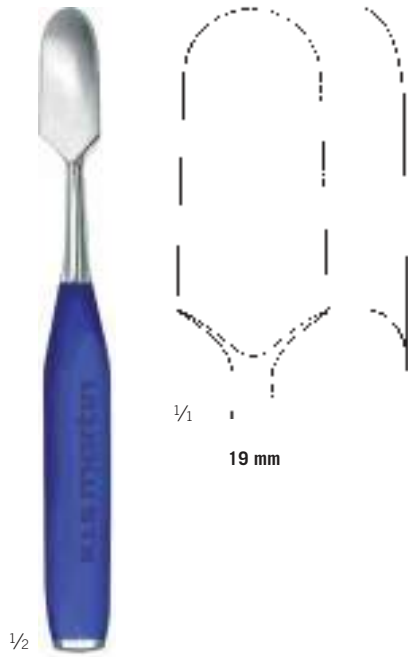

23-437-20-04
20 cm / 7 7/8"



23-438-03-07 -
23-438-06-07
17 cm / 6 5/8"

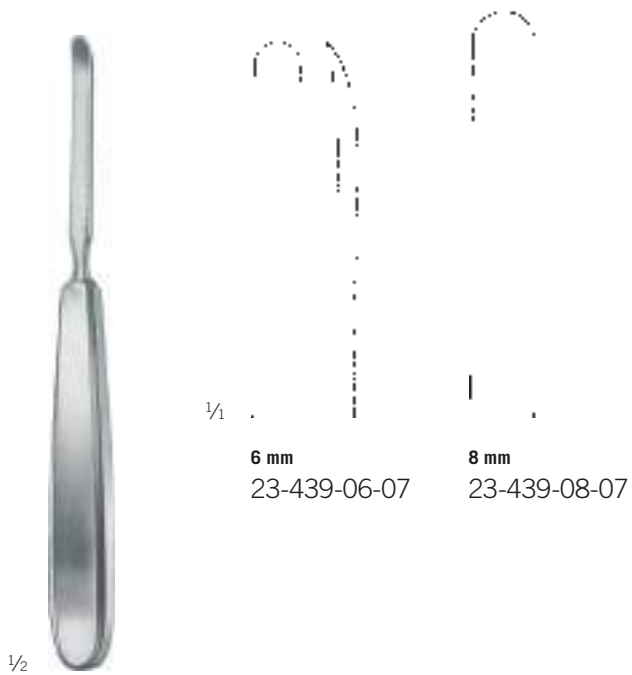

23-439-06-07 -
23-439-08-07
17 cm / 6 5/8"

mit Hohlheft
with hollow handle
con mango hueco
avec manche creux
con manico vuoto

Raspatorien

Periosteal Elevators
Periostótomos
Rugines-raspatoires
Periostotomi

Knochenchirurgie

Bone Surgery
Cirugía ósea
Chirurgie osseuse
Chirurgia ossea

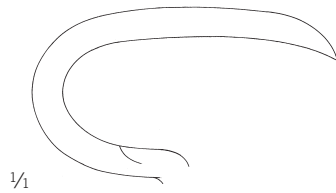
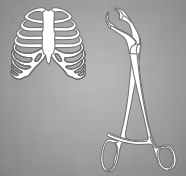

1/1

23-441-17-07

17 cm / 6 5/8"

rechts gebogen
right curved
curvo a la derecha
courbé à droite
curvo destro



23-443-17-07

17 cm / 6 5/8"

links gebogen
left curved
curvo a la izquierda
courbé à gauche
curvo sinistro

für Erwachsene
for adults
para adultos
pour adultes
per adulti

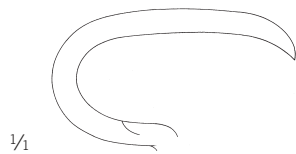

1/1

23-445-17-07

18 cm / 7 1/8"

rechts gebogen
right curved
curvo a la derecha
courbé à droite
curvo destro



23-447-17-07

18 cm / 7 1/8"

links gebogen
left curved
curvo a la izquierda
courbé à gauche
curvo sinistro

für Kinder
for children
para niños
pour enfants
per bambini



1/2

Doyen

23-441-17-07 -
23-447-17-07

Rippenraspatorien, mit Hohlheft
Rib Raspatories, with hollow handle
Legras costales, con mango hueco
Rugines pour le périoste costale, avec manche creux
Periostotomi costali, con manico vuoto

Raspatorien

Periosteal Elevators

Periostótomos

Rugines-raspatoires

Periostotomi

1/4

5 mm
23-461-05-07

1/4

12 mm
Fig. 1
23-450-01-07
19 cm / 7 4/8"

12 mm
Fig. 2
23-450-02-07
22 cm / 8 5/8"

10 mm
23-461-10-07

15 mm
23-461-15-07

20 mm
23-461-20-07

25 mm
23-461-25-07



1/2

Alexander
23-448-21-07
21 cm / 8 2/8"



1/2

Semb
23-450-01-07 -
23-450-05-07

13 mm
Fig. 3
23-450-03-07
19 cm / 7 4/8"

13 mm
Fig. 4
23-450-04-07
22 cm / 8 5/8"

15 mm
Fig. 5
23-450-05-07
23 cm / 9"



1/2

Lambotte
23-461-05-07 -
23-461-25-07
21,5 cm / 8 4/8"

Knochenfeilen

Bone Files
Limas para huesos
Limes à os
Lime per ossa

Knochenchirurgie

Bone Surgery
Cirugía ósea
Chirurgie osseuse
Chirurgia ossea

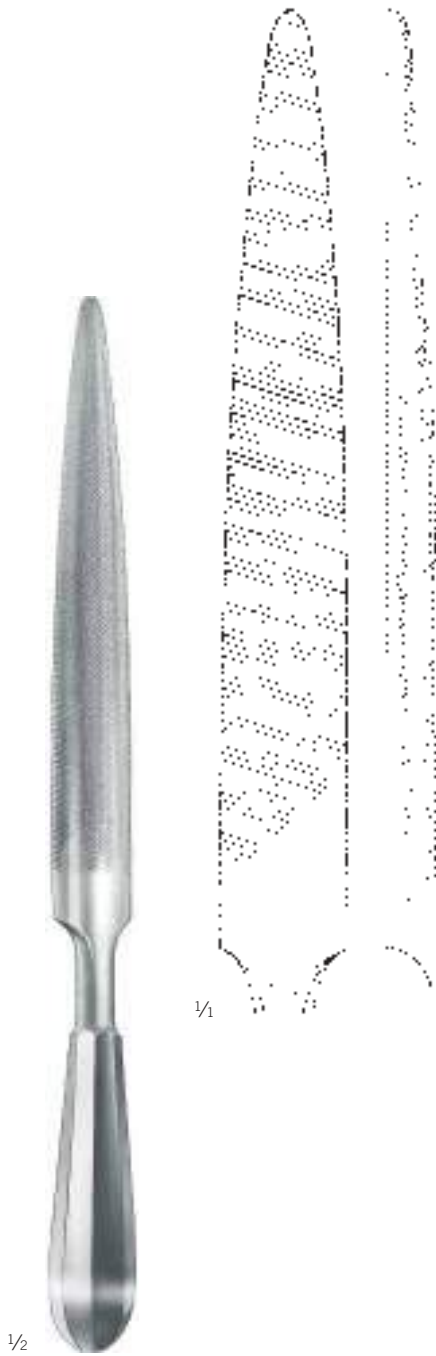
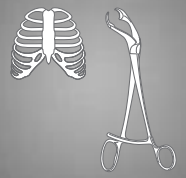

23-479-28-07

28 cm / 11 "

halbrund, mit Hohlheft
semi round, with hollow handle
semi-redonda, con mango hueco
semi-ronde, avec manche creux
semi-rotonda, con manico vouto

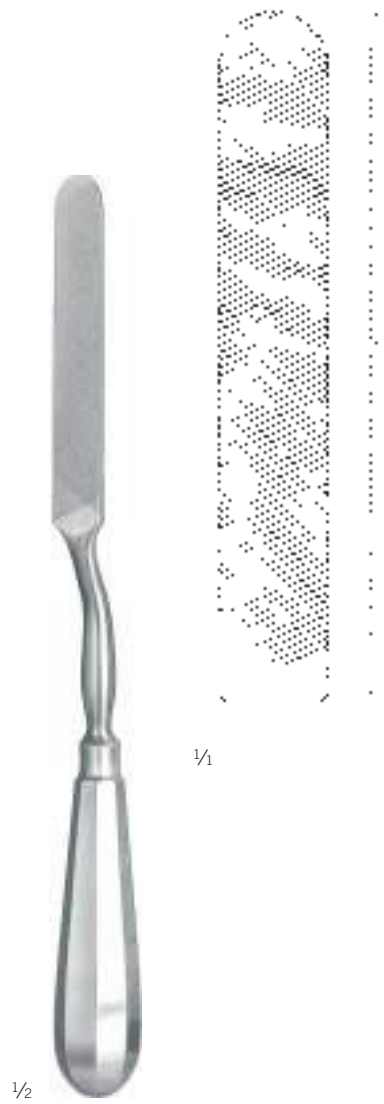

23-481-24-07

25 cm / 9 7/8"

halbrund, mit Hohlheft
semi round, with hollow handle
semi-redonda, con mango hueco
semi-ronde, avec manche creux
semi-rotonda, con manico vouto



23-482-22-07

22 cm / 8 5/8"

flach, massiv
flat, solid
plana, maciza
plate, solide
plana, solida

Elevatorien, Knochenfeilen

Elevators, Bone Files
 Elevadores, Limas para huesos
 Elévateurs, Limes à os
 Elevatori, Lime per ossa



1/1

23-484-17-07
 17 cm / 6 5/8"

23-485-17-07
 17,5 cm / 6 7/8"

23-486-17-07
 17,5 cm / 6 7/8"

23-487-17-07
 17 cm / 6 5/8"

1/2

Adson
 23-484-17-07 -
 23-487-17-07



Fig. 1
 23-490-01-07
 18 cm / 7 1/8"

Fig. 2
 23-490-02-07
 18 cm / 7 1/8"

Fig. 3
 23-490-03-07
 18 cm / 7 1/8"

Fig. 4
 23-490-04-07
 18 cm / 7 1/8"

Fig. 5
 23-490-05-07
 18 cm / 7 1/8"

1/2

1/1

Miller-Colburn
 23-490-01-07 -
 23-490-05-07

auf Zug schneidend
 downwards cutting
 corte abajo
 tranchant en bas
 tagliente in basso

Knochenfeilen, Alveotomiefeilen

Bone Files, Alveotomy Files

Limas para huesos, Limas para alveolotomí

Limes à os, Limes pour alvéolotomie

Lime per ossa, Lime per alveolotomia

Knochenchirurgie

Bone Surgery

Cirugía ósea

Chirurgie osseuse

Chirurgia ossea

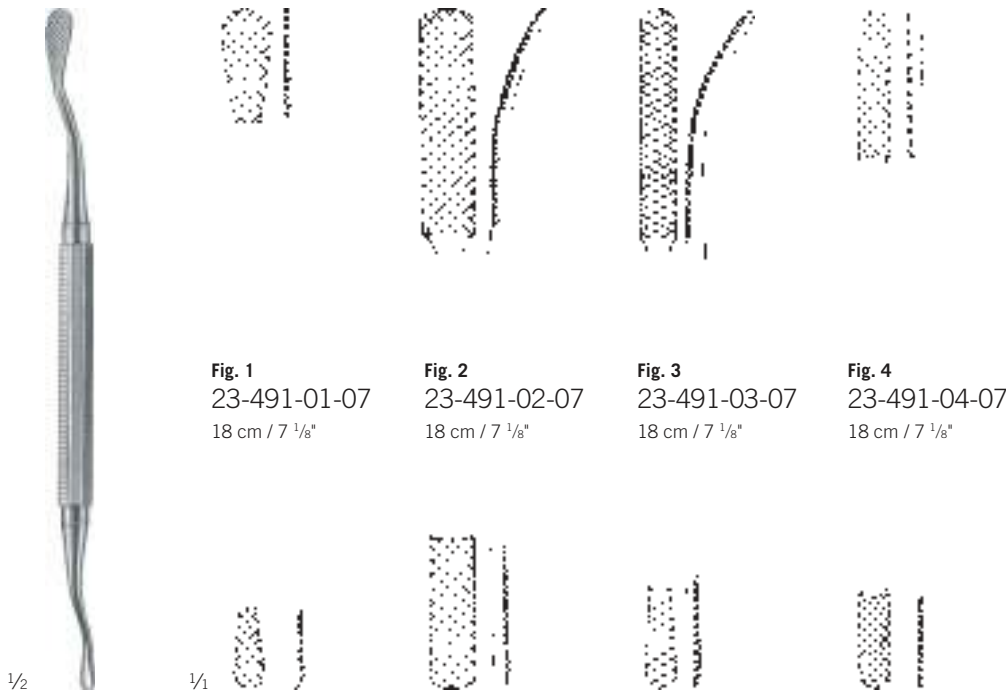
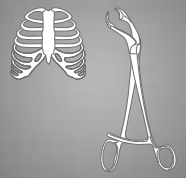

Fig. 1
23-491-01-07
18 cm / 7 1/8"

Fig. 2
23-491-02-07
18 cm / 7 1/8"

Fig. 3
23-491-03-07
18 cm / 7 1/8"

Fig. 4
23-491-04-07
18 cm / 7 1/8"

Miller-Colburn
23-491-01-07 -
23-491-04-07

Kreuzhieb
cross cut
picado en cruz
taille croisée
tagliente a croce

TC GOLD



Miller
23-492-01-07
19 cm / 7 4/8"

TC GOLD



Miller
23-493-01-07
19 cm / 7 4/8"

Elevatorien

Elevators
Elevadores
Elévateurs
Elevatori



1/1

7 mm
23-495-20-07
19,5 cm / 7 5/8"

10 mm
23-497-20-07
19,5 cm / 7 5/8"

11 mm
23-498-23-07
23 cm / 9"

1/2

Langenbeck
23-495-20-07 -
23-498-23-07



1/1

5 mm
23-499-01-07
17 cm / 6 6/8"

7 mm
23-499-02-07
17 cm / 6 6/8"

8 mm
23-499-03-07
19,5 cm / 7 5/8"

10 mm
23-499-04-07
19,5 cm / 7 5/8"

1/2

Martin-Langenbeck
23-499-01-07 -
23-499-04-07

massiv
solid
macizo
solide
pieno

Elevatorenien

Elevators
Elevadores
Élévateurs
Elevatori

Knochenchirurgie

Bone Surgery
Cirugía ósea
Chirurgie osseuse
Chirurgia ossea

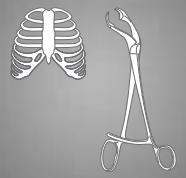

Williger
23-510-17-07
17 cm / 6 5/8"
massiv
solid
macizo
solide
pieno

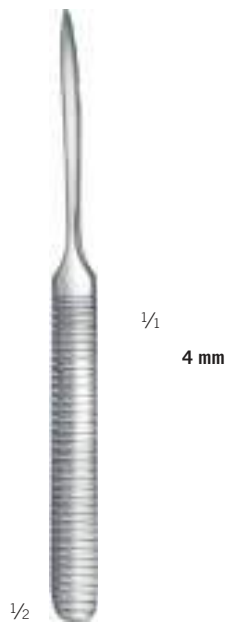

Williger
23-513-16-07
16 cm / 6 2/8"
massiv
solid
macizo
solide
pieno

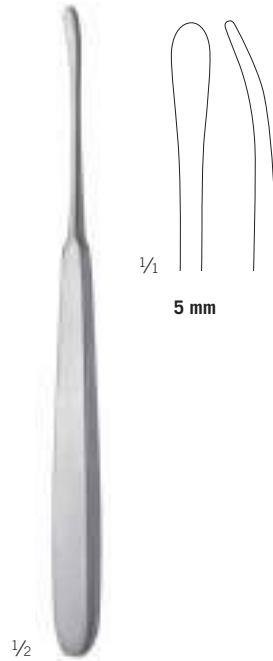

Sebileau
23-516-18-07
17,5 cm / 6 7/8"

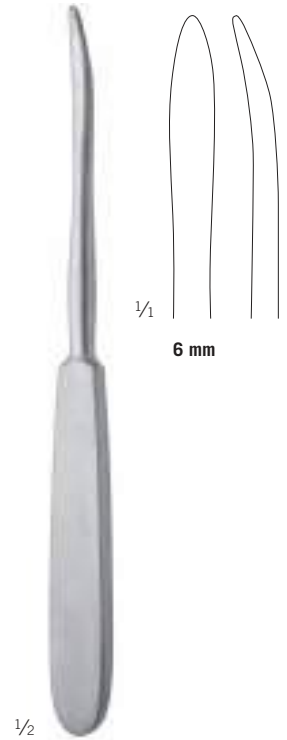

Quervain
23-517-20-07
19,5 cm / 7 5/8"



Alderdyce
23-525-21-07
21 cm / 8 2/8"



23-526-18-07
18 cm / 7 1/8"



McDonald
23-527-19-07
18,5 cm / 7 2/8"

Knochenheber

Bone Levers

Elevadores para hueso

Leviers à os

Elevatori per ossa



23-537-06-07
15 cm / 5 7/8"



Hohmann, mini
23-539-06-07 -
23-539-08-07
16 cm / 6 2/8"

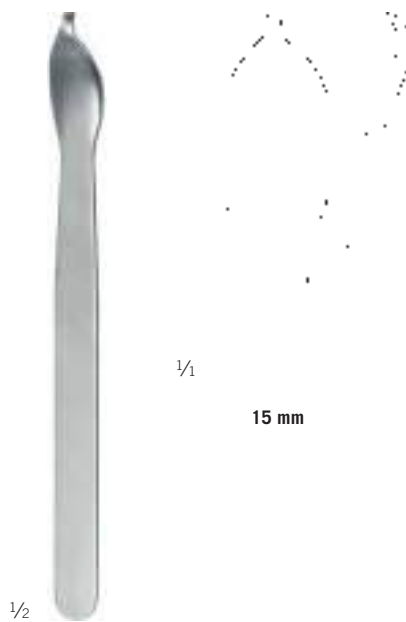

23-539-15-07
16 cm / 6 2/8"

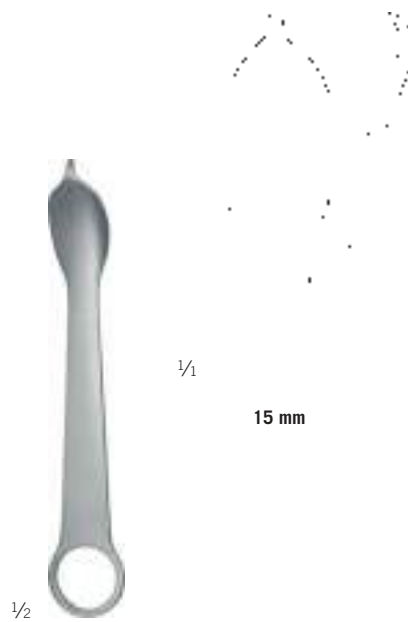

23-539-16-07
12 cm / 4 6/8"

Knochenheber

Bone Levers
Elevadores para hueso
Leviers à os
Elevatori per ossa

Knochenchirurgie

Bone Surgery
Cirugía ósea
Chirurgie osseuse
Chirurgia ossea

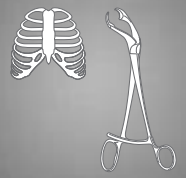

8 mm

Hohmann
23-541-08-07
21,5 cm / 8 ⁴/₈"
schmale Spitze
narrow tip
punta estrecha
pointe étroite
punta stretta



18 mm

Hohmann
23-541-18-07
23,5 cm / 9 ²/₈"
schmale Spitze
narrow tip
punta estrecha
pointe étroite
punta stretta



43 mm

Hohmann
23-541-43-07
23,5 cm / 9 ²/₈"
schmale Spitze
narrow tip
punta estrecha
pointe étroite
punta stretta

Knochenhebel

Bone Levers

Elevadores para hueso

Leviers à os

Elevatori per ossa



1/2

70 mm
Hohmann
23-541-70-07

25 cm / 9 7/8"
schmale Spitze
narrow tip
punta estrecha
pointe étroite
punta stretta



1/2

43 mm
Hohmann
23-543-43-07

23,5 cm / 9 2/8"
schmale Spitze
narrow tip
punta estrecha
pointe étroite
punta stretta



1/2

22 mm
Hohmann
23-545-22-07

25,5 cm / 10 "
breite Spitze
wide tip
punta ancha
pointe large
punta larga

Knochenheber

Bone Levers
Elevadores para hueso
Leviers à os
Elevatori per ossa

Knochenchirurgie

Bone Surgery
Cirugía ósea
Chirurgie osseuse
Chirurgia ossea

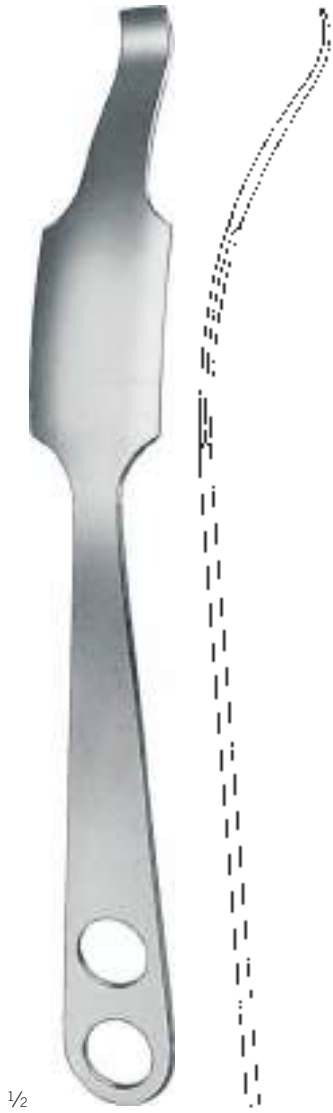
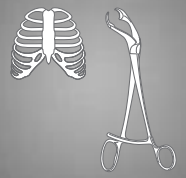

1/2

35 mm

Hohmann
23-545-35-07

29 cm / 11 3/8"

breite Spitze
wide tip
punta ancha
pointe large
punta larga



1/2

24 mm

Hohmann
23-547-24-07

27,5 cm / 10 7/8"

breites, rundes Ende
wide, round tip
punta ancha, redonda
pointe large, ronde
punta larga, rotonda



1/2

22 mm

Lange-Hohmann
23-549-22-07

25 cm / 9 7/8"

breite Spitze mit Längsrille
wide tip with groove
punta ancha con ranura
pointe large avec rainure
punta larga con scanallatura

Knochenhebel

Bone Levers

Elevadores para hueso

Leviers à os

Elevatori per ossa



1/2

Bennett
23-559-24-01 -
23-561-24-01

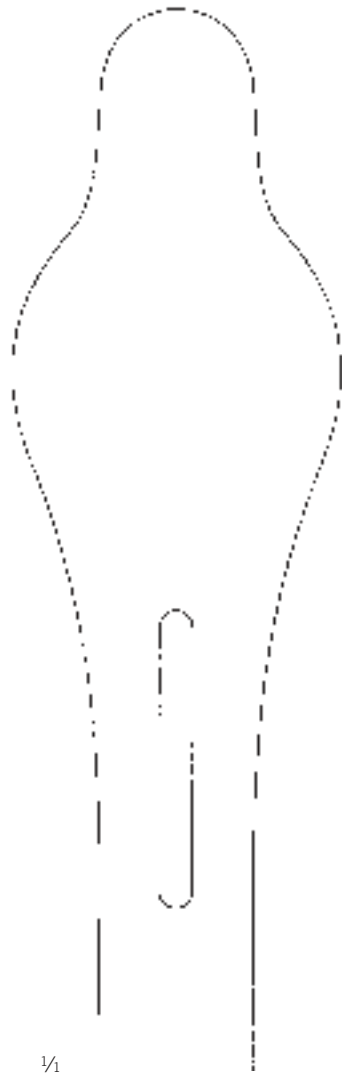

1/1

43 mm
23-559-24-01
24 cm / 9 4/8"

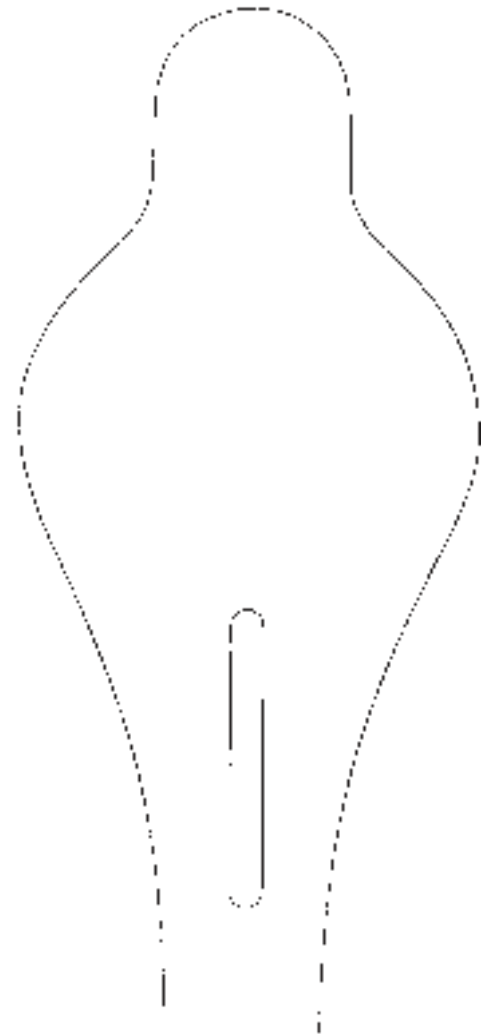

60 mm
23-561-24-01
23,5 cm / 9 2/8"

Kniehaken, Spinalhaken

Knee Retractors, Spinal Retractors

Separadores para rodilla, Separadores espinales

Ecarteurs pour le genou, Ecarteurs spinaux

Divaricatori per il ginocchio, Divaricatori spinali

Knochenchirurgie

Bone Surgery

Cirugía ósea

Chirurgie osseuse

Chirurgia ossea

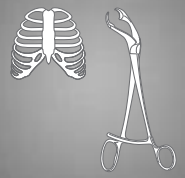

1/3

39 mm

Blount

23-563-26-07

26,5 cm / 10 3/8"

stumpf
blunt
romo
mousse
smusso



1/3

47 mm

Blount

23-565-26-07

26,5 cm / 10 3/8"

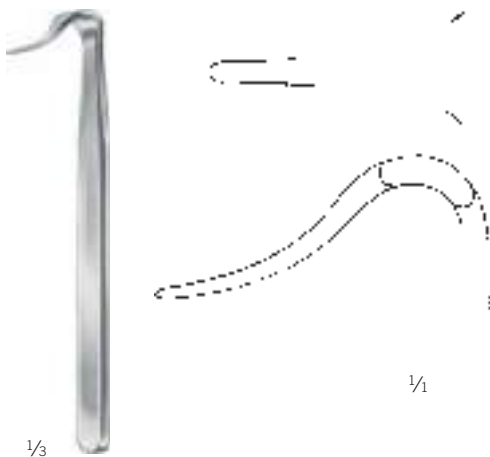

1/3

Blount

23-567-17-07

17,5 cm / 6 7/8"

1/1



1/3

Taylor

23-571-16-07 -
23-573-16-07

16 cm / 6 3/8"

1/1

95 x 30 mm

23-571-16-07

16 cm / 6 3/8"

115 x 30 mm

23-573-16-07

16 cm / 6 3/8"

Meniskotome, Meniskusmesser

Meniscus Knives

Cuchillos para menisco

Bistouris à ménisque

Meniscotomi



1/1

Fig. 1
23-630-17-07

Fig. 2
23-631-17-07

Fig. 3
23-633-17-07

1/2

23-630-17-07 -
23-633-17-07
17,5 cm / 6 7/8"

1/1

Fig. 1
23-643-22-07

Fig. 2
23-645-22-07

1/2

Neff
23-643-22-07 -
23-645-22-07
22 cm / 8 5/8"

1/2

Salenius
23-650-22-07
21,5 cm / 8 4/8"

1/2

Salenius
23-651-22-07
21,5 cm / 8 4/8"

Sehnenstripper

Tendon Strippers

Enucleadores de tendones

Instruments à écorcher les tendons

Scollatendini

Knochenchirurgie

Bone Surgery

Cirurgia ósea

Chirurgie osseuse

Chirurgia ossea

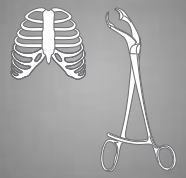

1/1

Fig. 1
23-652-01-07
15 cm / 5 7/8"
Ø 4,5 mm



Fig. 2
23-652-02-07
15 cm / 5 7/8"
Ø 5,5 mm



Fig. 3
23-652-03-07
15 cm / 5 7/8"
Ø 6,5 mm



Fig. 4
23-652-04-07
15 cm / 5 7/8"
Ø 7,5 mm

Fig. 5
23-652-05-07
15 cm / 5 7/8"
Ø 8,5 mm



1/2

Bunnell
23-652-01-07 -
23-652-05-07
15 cm / 5 7/8"

1/1

23-654-40-07
23 cm / 9 "
Ø 4 mm



23-654-45-07
23 cm / 9 "
Ø 4,5 mm



23-654-55-07
23 cm / 9 "
Ø 5,5 mm



1/2

23-654-40-07 -
23-654-55-07
23 cm / 9 "
flexibler Schaft
flexible shaft
vástago flexible
tige flexible
gambo flessibile

1/1

23-656-01-07
Schraube
Screw
Tornillo
Vis
Vite



23-656-00-07



1/2

23-656-00-07 -
23-656-01-07
33,5 cm / 13 2/8"
Sehnedurchzuginstrument
Tendon Passing Instrument
Pasador de tendones
Instrument pour passer les tendons
Scollatendini

Sehnenstripper

Tendon Strippers

Enucleadores de tendones

Instruments à écorcher les tendons

Scollatendini



1/1

1/2

Fischer
23-660-31-07

31 cm / 12 2/8"

stumpf
blunt
romo
mousse
smusso



1/1

1/2

23-662-29-07

28,5 cm / 11 2/8"



1/1

1/2

Bunnell
23-664-23-02

23 cm / 9"

biegsam
malleable
maleable
malléable
malleabili
Sehnen durchzugs sonde
Tendon Passer
Sonda conductora de tendones
Sonde conductrice pour tendons
Sonda conduttrice per tendini

Sehnenfasszangen, Sehnendurchzugzangen

Tendon Holding Forceps, Tendon Tunnelling Forceps
 Pinzas para coger tendones, Pinzas para pasar tendones
 Pincers pour saisir les tendons, Pincers pour passer les tendons
 Pinze per afferrare tendini, Pinze passa-tendini

Knochenchirurgie

Bone Surgery
 Cirugía ósea
 Chirurgie osseuse
 Chirurgia ossea

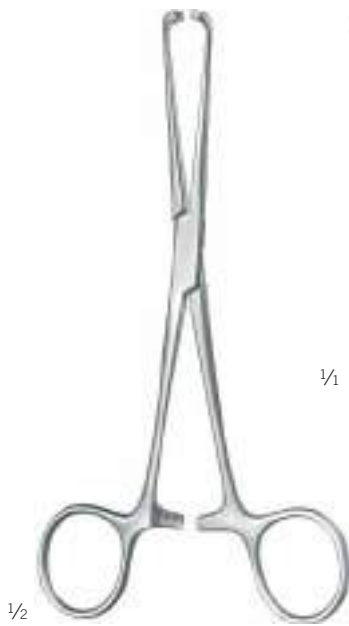
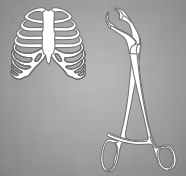

Steinmann
 23-674-16-07
 16 cm / 6 2/8"



Brand
 23-676-15-07 -
 23-676-24-07

1/1			
	23-676-15-07 15 cm / 5 7/8"	23-676-19-07 19 cm / 7 4/8"	23-676-24-07 24,5 cm / 9 5/8"
	2:3	2:3	2:3



23-678-00-07 -
 23-678-01-07

1/1		
	23-678-00-07 21 cm / 8 2/8"	23-678-01-07 20,5 cm / 8 1/8"
	2:3	2:3



Carroll
 23-679-11-07
 11,5 cm / 4 4/8"

Sehnenfazzangen, Sehneneflechtklennen

Tendon Holding Forceps, Tendon Interlacing Forceps

Pinzas para coger tendones, Pinzas para entrelazar tendones

Pinces pour saisir les tendons, Pinces pour entrelacer les tendons

Pinze per afferrare tendini, Pinze per allacciare tendini



1/2

23-680-13-07

11,5 cm / 4 1/8"



1/2

Kleinert-Kutz
23-681-20-07

21 cm / 8 2/8"

Schaftlänge

shaft length

longitud del vástago

longueur de la tige

lunghezza dell'asta

140 mm



1/2

23-682-15-07

15 cm / 5 7/8"



1/2

23-683-15-07

15 cm / 5 7/8"

Knorpelfasszangen, Knochenhaltezangen

Cartilage Seizing Forceps, Bone Holding Forceps

Pinzas para cartílago, Pinzas para hueso

Pinces à cartilage, Daviers porte-os

Pinze per cartilagine, Tenaglie per ossa

Knochenchirurgie

Bone Surgery

Cirugía ósea

Chirurgie osseuse

Chirurgia ossea

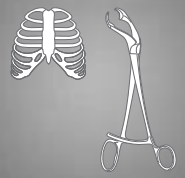

1/1

Knochenhaltezange
Bone Holding Forceps
Pinza para hueso
Daviers porte-os
Tenaglio per ossa

1/2

23-704-14-07

14,5 cm / 5 7/8"



1/1

23-710-20-07

21 cm / 8 2/8"

gerade
straight
recta
droite
diritta

1/2

Bircher-Ganske

23-710-20-07 -

23-711-20-07



23-711-20-07

20,5 cm / 8 1/8"

aufgebogen
curved upwards
curva por arriba
courbée en haut
curva in alto

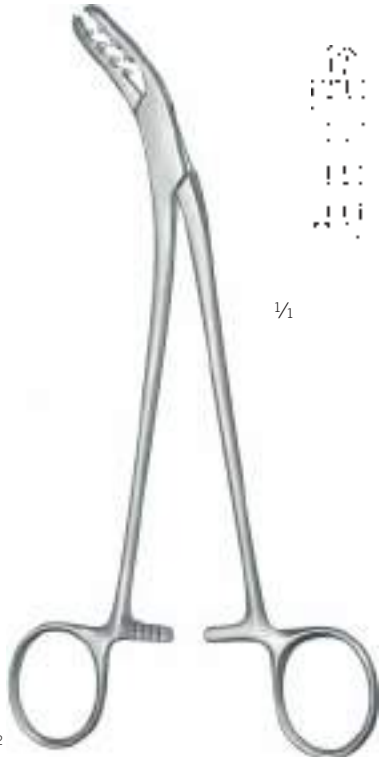

1/1

1/2

Bircher-Ganske

23-713-20-07

20 cm / 7 7/8"

seitwärts gebogen
curved sideways
curva lateralmente
courbée latéralement
curva lateralmente



1/1

1/2

Dingmann

23-715-19-07

18,5 cm / 7 2/8"

Knorpelfasszangen, Repositionszangen, Knochenhaltezangen

Cartilage Seizing Forceps, Reposition Forceps, Bone Holding Forceps

Pinzas para cartilago, Pinzas para reposición, Pinzas para hueso

Pinces à cartilage, Pinces à réduction, Daviers porte-os

Pinze per cartilagine, Pinze per riposizioni, Tenaglie per ossa



Martin
23-716-19-07
18,5 cm / 7 2/8"



23-717-12-07
13,5 cm / 5 3/8"
lange Sperre
long ratchet
cremallera larga
cremallière longue
cremagliera lunga



Lewin
23-718-17-07
18 cm / 7 1/8"



23-720-14-07
14 cm / 5 4/8"
grazil
delicate
delicada
gracile
sottile



23-721-09-07
9 cm / 3 4/8"
lange Sperre
long ratchet
cremallera larga
cremallière longue
cremagliera lunga



23-721-14-07
15 cm / 5 7/8"
lange Sperre
long ratchet
cremallera larga
cremallière longue
cremagliera lunga

Knochenhalte­zangen

Bone Holding Forceps
Pinzas para hueso
Daviers porte-os
Tenaglie per ossa

Knochenchirurgie

Bone Surgery
Cirugía ósea
Chirurgie osseuse
Chirurgia ossea

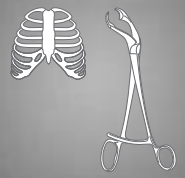

Langenbeck
23-722-21-07
21 cm / 8 2/8"

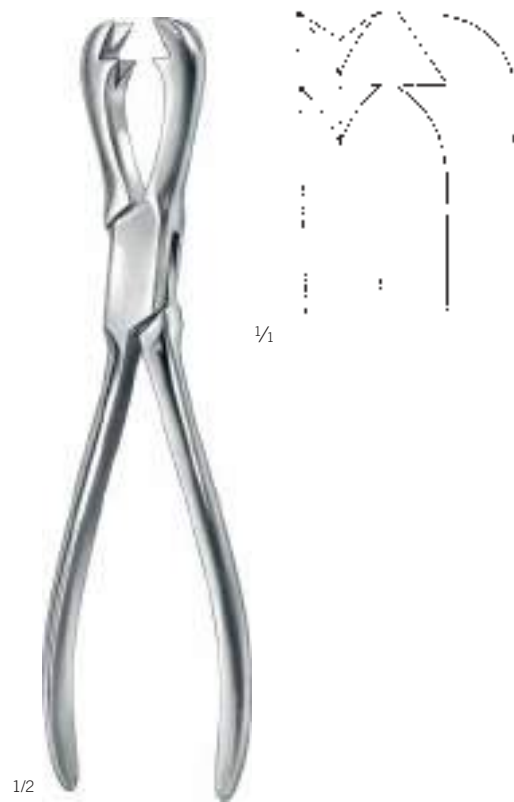

Fergusson
23-724-21-07
21 cm / 8 2/8"
kräftiges Modell
heavy pattern
modelo fuerte
modèle fort
modello forte



Frosch
23-726-18-07
18 cm / 7 1/8"

Knochenhaltezangen

Bone Holding Forceps

Pinzas para hueso

Daviers porte-os

Tenaglie per ossa



23-727-20-07
20 cm / 7 7/8"



23-729-16-07
17,5 cm / 6 7/8"
mit Gewindesperre
with thread fixation
con cremallera de rosca
avec cremallière fileté
con cremagliera a filettatura



23-729-24-07
24 cm / 9 4/8"
mit Gewindesperre
with thread fixation
con cremallera de rosca
avec cremallière fileté
con cremagliera a filettatura

Knochenhaltezangen, Repositionszangen

Bone Holding Forceps, Reposition Forceps

Pinzas para hueso, Pinzas para reposición

Daviers porte-os, Pincas à réduction

Tenaglie per ossa, Pinze per riposizioni

Knochenchirurgie

Bone Surgery

Cirugía ósea

Chirurgie osseuse

Chirurgia ossea

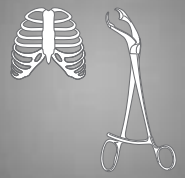

1/2

Kern
23-730-17-07 -
23-730-21-07

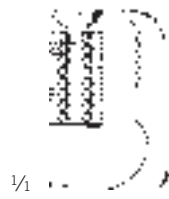

1/1

23-730-17-07
17 cm / 6 5/8"



23-730-21-07
24,5 cm / 9 5/8"



1/2

Semb
23-731-19-07
19,5 cm / 7 5/8"
seitwärts gebogen
curved sideways
curva lateralmente
courbée latéralement
curva lateralmente



1/1

Knochenhaltezangen

Bone Holding Forceps

Pinzas para hueso

Daviers porte-os

Tenaglie per ossa

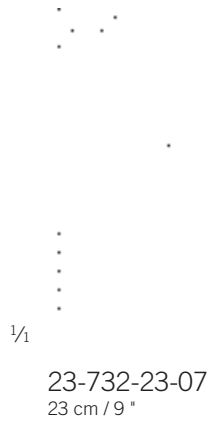

23-732-23-07
23 cm / 9"

23-732-26-07
26 cm / 10 3/8"

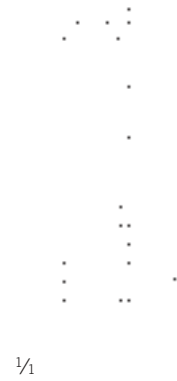

Farabeuf
23-734-26-07
26 cm / 10 3/8"

1/2

1/2

Farabeuf
23-732-23-07 -
23-732-26-07

Knochenhaltezangen

Bone Holding Forceps

Pinzas para hueso

Daviers porte-os

Tenaglia per ossa

Knochenchirurgie

Bone Surgery

Cirugía ósea

Chirurgie osseuse

Chirurgia ossea

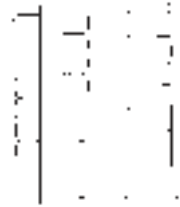
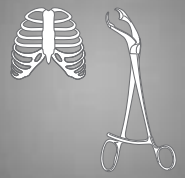

1/1

23-746-23-07
23 cm / 9"

23-746-25-07
25 cm / 9 7/8"

23-746-28-07
28 cm / 11"

1/2

Ulrich
23-746-23-07 -
23-746-28-07

mit Gewindesperre
with thread fixation
con cremallera de rosca
avec cremallière filetée
con cremagliera a filettatura



1/1

23-747-23-07
23 cm / 9"

23-747-25-07
25 cm / 9 7/8"

23-747-28-07
27 cm / 10 5/8"

1/2

Ulrich
23-747-23-07 -
23-747-28-07

mit Gewindesperre
with thread fixation
con cremallera de rosca
avec cremallière filetée
con cremagliera a filettatura

Knochenhaltezangen

Bone Holding Forceps

Pinzas para hueso

Daviers porte-os

Tenaglie per ossa



1/1

23-749-15-07
15 cm / 5 7/8"



23-749-19-07
20 cm / 7 7/8"

23-749-24-07
24 cm / 9 4/8"

23-749-26-07
26 cm / 10 2/8"



1/2

23-749-90-98

Rändelmutter
Knurled nut
Tuerca moleteada
Ecrou moleté
Madrevite zigrinata



23-749-15-07 -
23-749-28-07

23-749-28-07
28 cm / 11"

23-749-15-07 -
23-749-90-07

selbstzentrierend, mit Gewindesperre
self-centering, with thread fixation
autocentrante, con cremallera de rosca
à centrage automatique, avec cremallière fileté
centraggio automatico, con cremagliera a filettatura

Knochenhaltezangen

Bone Holding Forceps

Pinzas para hueso

Daviers porte-os

Tenaglie per ossa

Knochenchirurgie

Bone Surgery

Cirurgia ósea

Chirurgie osseuse

Chirurgia ossea

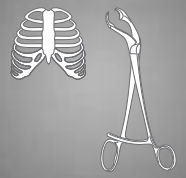

1/2

Lane
23-750-33-07 -
23-752-33-07
33 cm / 13 "

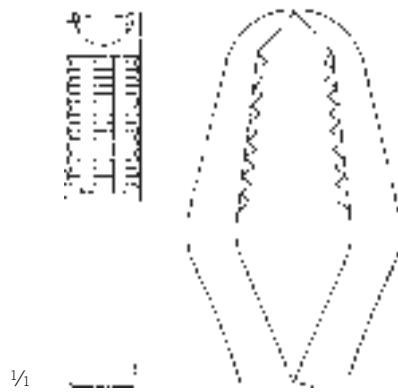

1/4

23-750-33-07

ohne Sperre
without ratchet
sin cremallera
sans cremallière
senza cremagliera

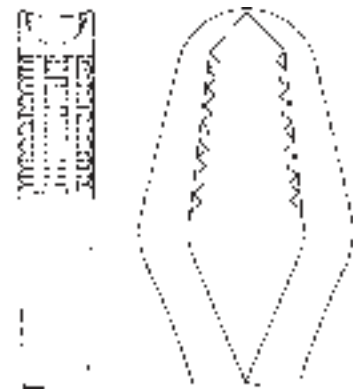

23-752-33-07

mit Sperre
with ratchet
con cremallera
avec cremallière
con cremagliera

Knochenhaltezangen

Bone Holding Forceps

Pinzas para hueso

Daviers porte-os

Tenaglie per ossa



1/1

23-755-01-07

25 cm / 9 7/8"

23-755-02-07

26 cm / 10 2/8"

23-755-03-07

27,5 cm / 10 7/8"

1/2

Verbrugge
23-755-01-07 -
23-755-03-07

Knochenhaltezangen, Amputationsschild

Bone Holding Forceps, Amputation Retractor
Pinzas para hueso, Retractor para amputación
Daviers porte-os, Retracteur pour amputation
Tenaglie per ossa, Retrattore per amputazione

Knochenchirurgie

Bone Surgery
Cirugía ósea
Chirurgie osseuse
Chirurgia ossea

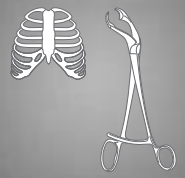

Verbrugge
23-757-01-07
17,5 cm / 6 7/8"



Percy
23-762-30-07
auseinandernehmbar
detachable
desmontable
démontable
smontabile

Hohlmeißelzangen

Bone Rongeurs

Pinzas gubias

Pinces-gouges

Pinze-sgorbie



23-777-01-07
17 cm / 6 5/8"

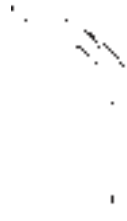

23-777-02-07
16,5 cm / 6 1/2"

1/2

Stellbrink
23-777-01-07 -
23-777-02-07



1/1

1/2

Friedmann
23-799-12-07
12,5 cm / 4 7/8"



1/1

1/2

Friedmann
23-801-14-07
13,5 cm / 5 3/8"



1/1

1/2

Friedmann
23-803-14-07
13,5 cm / 5 3/8"



1/1

1/2

Cleveland
23-805-14-07
13,5 cm / 5 3/8"



1/1

1/2

Cleveland
23-807-17-07
16,5 cm / 6 1/2"

Hohlmeißelzangen

Bone Rongeurs
Pinzas gubias
Pincès-gouges
Pinze-sgorbie

Knochenchirurgie

Bone Surgery
Cirugía ósea
Chirurgie osseuse
Chirurgia ossea

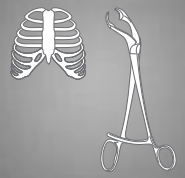

Mead
23-815-16-07
16,5 cm / 6 5/8"

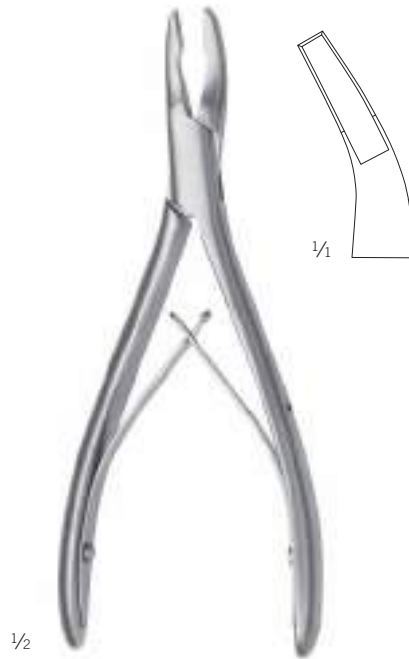

Mead
23-816-16-07
16,5 cm / 6 5/8"



Hartmann
23-819-18-07
17,5 cm / 6 7/8"



Jansen
23-826-18-07 -
23-829-18-07

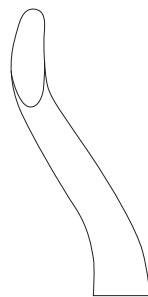

23-826-18-07
18 cm / 7 1/8"

23-828-18-07
18,5 cm / 7 3/8"

23-829-18-07
18 cm / 7 1/8"

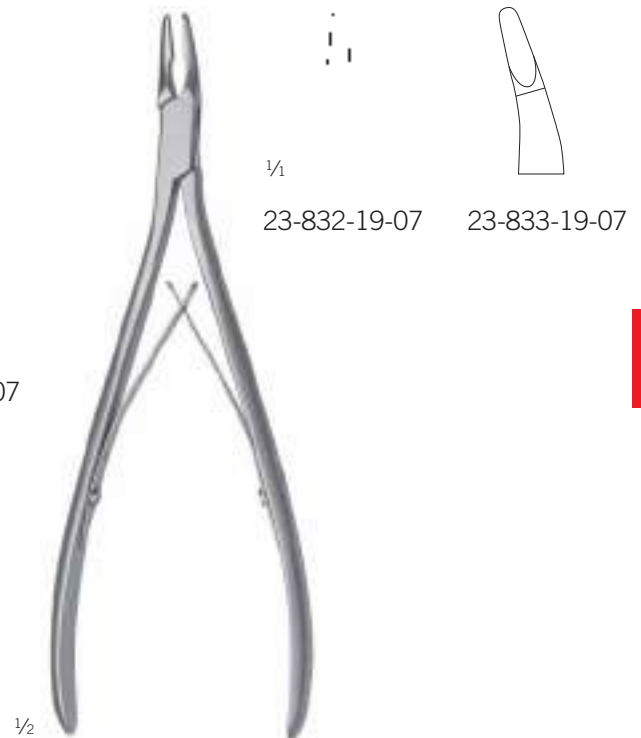

Lempert
23-832-19-07 -
23-833-19-07
19 cm / 7 5/8"

Hohlmeißelzangen

Bone Rongeurs

Pinzas gubias

Pinces-gouges

Pinze-sgorbie



1/1

23-835-15-07
16 cm / 6 2/8"

23-837-15-07
15,5 cm / 6 1/8"

23-839-15-07
15 cm / 5 7/8"

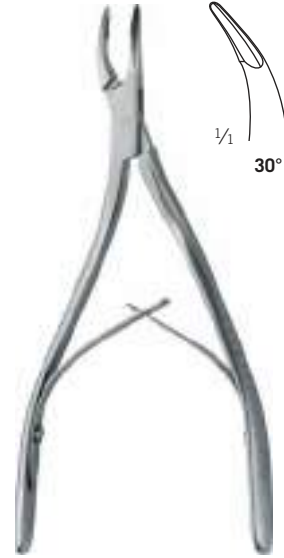

1/1
30°

1/2

1/2

Blumenthal
23-835-15-07 -
23-839-15-07

23-835-30-07
15,5 cm / 6 1/8"
S-Form
S-shape
forma S
courbé en S
curvo in forma S

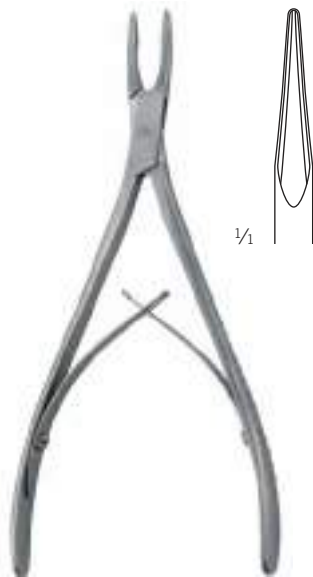

1/1

1/1
30°

1/1

30°

1/2

1/2

23-836-00-07
15,5 cm / 6 1/8"

23-836-30-07
15,5 cm / 6 1/8"



1/1
90°

1/2

23-836-90-07
14,5 cm / 5 6/8"

Hohlmeißelzangen

Bone Rongeurs
Pinzas gubias
Pincès-gouges
Pinze-sgorbie

Knochenchirurgie

Bone Surgery
Cirugía ósea
Chirurgie osseuse
Chirurgia ossea

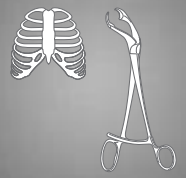

1/1

23-846-17-07
18,5 cm / 7 2/8"

23-847-17-07
18 cm / 7 1/8"

1/2

Luer
23-846-17-07 -
23-847-17-07



1/1

23-853-15-07
14,5 cm / 5 6/8"

23-864-15-07
14,5 cm / 5 6/8"

23-865-15-07
14,5 cm / 5 6/8"

1/2

Luer
23-853-15-07 -
23-865-15-07



1/1

23-876-15-07

23-877-15-07

1/2

Böhler
23-876-15-07 -
23-877-15-07
15 cm / 5 7/8"



1/1

1/2

Beyer
23-879-18-07
18 cm / 7 1/8"



1/1

1/2

Zaufal-Jansen
23-881-18-07
18 cm / 7 1/8"

Hohlmeißelzangen

Bone Rongeurs

Pinzas gubias

Pinces-gouges

Pinze-sgorbie



1/1

1/2

Mayfield
23-883-17-07
18 cm / 7 1/8"



1/1

1/2

Marquard
23-885-20-07
20,5 cm / 8 1/8"



1/1

1/2

Ruskin
23-887-18-07
19 cm / 7 4/8"



1/1

1/2

Ruskin
23-893-23-07
24 cm / 9 4/8"



1/1

1/2

Semb
23-895-22-07
23,5 cm / 9 2/8"



1/1

1/2

Stille
23-897-23-07
22,5 cm / 8 7/8"

Hohlmeißelzangen

Bone Rongeurs
Pinzas gubias
Pinces-gouges
Pinze-sgorbie

Knochenchirurgie

Bone Surgery
Cirugía ósea
Chirurgie osseuse
Chirurgia ossea

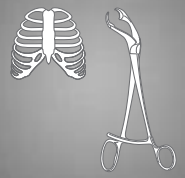

1/2

Echlin
23-899-02-07 -
23-899-04-07
23 cm / 9"

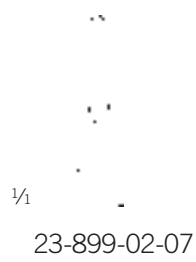

1/4

23-899-02-07

..

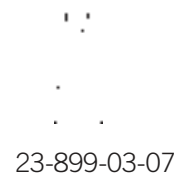

23-899-03-07

..



23-899-04-07



1/2

Stille-Ruskin
23-901-23-07
23,5 cm / 9 2/8"



1/4

Hohlmeißelzangen

Bone Rongeurs

Pinzas gubias

Pinces-gouges

Pinze-sgorbie



1/2

Leksell-Stille
23-905-24-07 -
23-907-24-07
24,5 cm / 9 5/8"



1/4

23-905-24-07

23-907-24-07



1/2

Frykholm
23-909-24-07
24,5 cm / 9 5/8"



1/4

Hohlmeißelzangen

Bone Rongeurs
Pinzas gubias
Pincès-gouges
Pinze-sgorbie

Knochenchirurgie

Bone Surgery
Cirugía ósea
Chirurgie osseuse
Chirurgia ossea

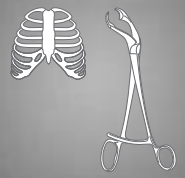

1/2

Stille-Luer
23-910-22-07 -
23-911-22-07
22,5 cm / 8 7/8"



1/4

23-910-22-07

23-911-22-07



1/2

Stille-Luer
23-912-23-07 -
23-913-27-07



1/4

23-912-23-07
23 cm / 9"

23-913-23-07
23 cm / 9"

23-912-27-07
27 cm / 10 5/8"

23-913-27-07
27 cm / 10 5/8"

Hohlmeißelzangen

Bone Rongeurs

Pinzas gubias

Pinces-gouges

Pinze-sgorbie



1/2

Sauerbruch
23-916-30-07 -
23-918-30-07

31 cm / 12 2/8"

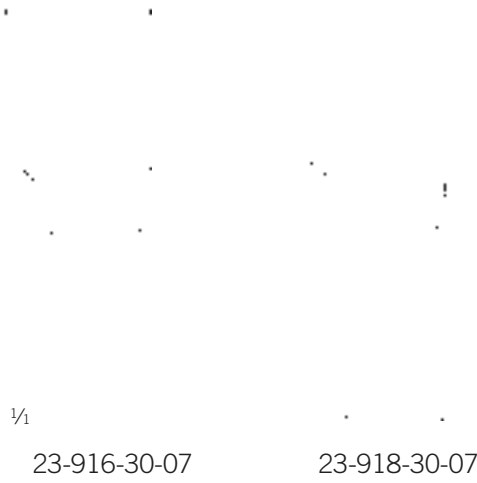

1/1

23-916-30-07

23-918-30-07

Knochensplitterzangen

Bone Cutting Forceps
Pinzas cortantes para hueso
Pincers coupantes à os
Cesoie per ossa

Knochenchirurgie

Bone Surgery
Cirugía ósea
Chirurgie osseuse
Chirurgia ossea

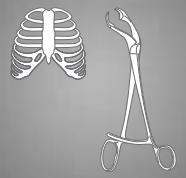

Cottle-Kazanjian
23-930-19-07
19 cm / 7 4/8"



1/2
Liston
23-934-14-07 -
23-934-22-07



1/2
Liston
23-935-14-07 -
23-935-22-07

1/1

23-934-14-07
14 cm / 5 4/8"

23-934-17-07
17 cm / 6 5/8"

23-934-19-07
20 cm / 7 7/8"

23-934-22-07
22 cm / 8 5/8"

1/1

23-935-14-07
14 cm / 5 4/8"

23-935-17-07
17 cm / 6 5/8"

23-935-19-07
20 cm / 7 7/8"

23-935-22-07
22 cm / 8 5/8"

Knochensplitterzangen

Bone Cutting Forceps
Pinzas cortantes para hueso
Pinces coupantes à os
Cesoie per ossa



Cleveland
23-939-17-07
17 cm / 6 5/8"

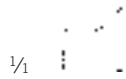

Cleveland
23-941-15-07
14,5 cm / 5 5/8"

1/4

1/2



Böhler
23-944-15-07
14,5 cm / 5 5/8"

1/4



Böhler
23-946-15-07
14,5 cm / 5 5/8"

1/4



1/2



Cleveland
23-947-16-07
17 cm / 6 5/8"

1/4

1/2

Knochensplitterzangen

Bone Cutting Forceps
Pinzas cortantes para hueso
Pincers coupantes à os
Cesoie per ossa

Knochenchirurgie

Bone Surgery
Cirugía ósea
Chirurgie osseuse
Chirurgia ossea

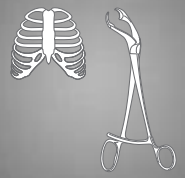

1/2

Ruskin-Liston
23-950-18-07 -
23-951-18-07



1/4

23-950-18-07
19 cm / 7 4/8"



23-951-18-07
18,5 cm / 7 2/8"



1/2

Stille-Liston
23-952-27-07
26 cm / 10 2/8"

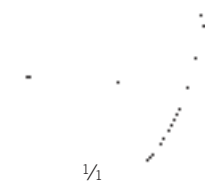

1/4

Knochensplitterzangen

Bone Cutting Forceps
Pinzas cortantes para hueso
Pinces coupantes à os
Cesoie per ossa



1/2
Stille-Liston
23-954-27-07
28 cm / 11 "

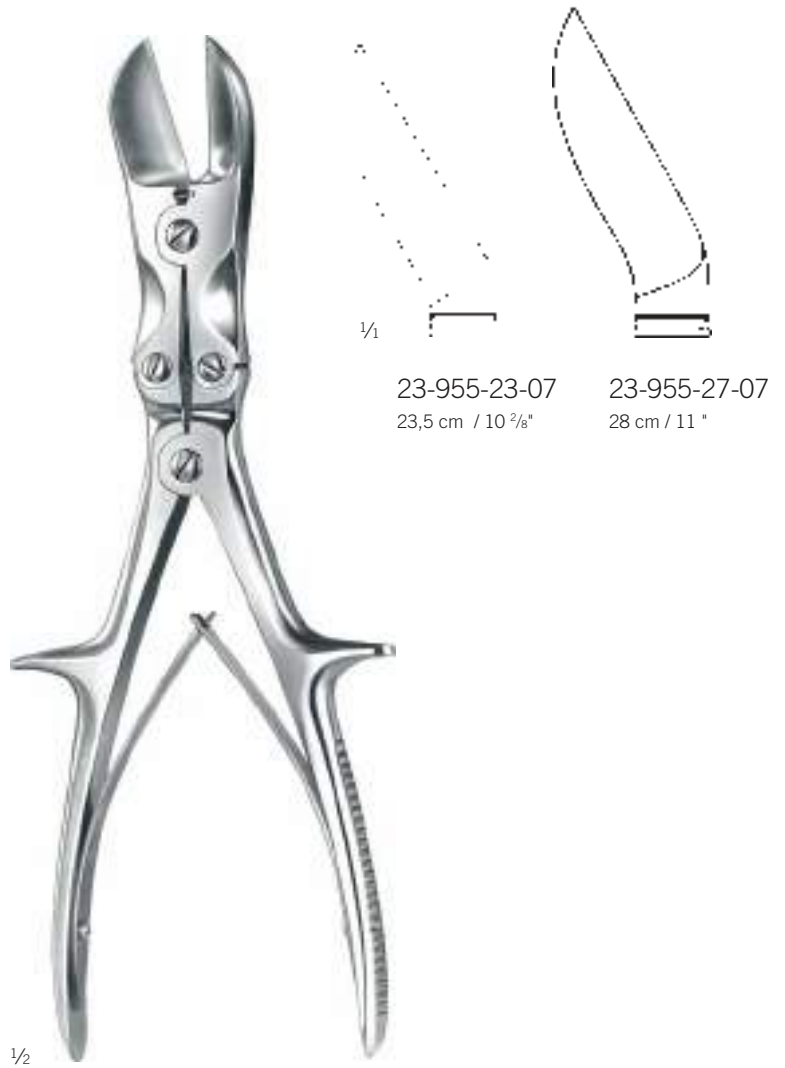

1/4
23-955-23-07
23,5 cm / 10 2/8"

23-955-27-07
28 cm / 11 "

Knochensplitterzangen

Bone Cutting Forceps
Pinzas cortantes para hueso
Pinces coupantes à os
Cesoie per ossa

Knochenchirurgie

Bone Surgery
Cirugía ósea
Chirurgie osseuse
Chirurgia ossea

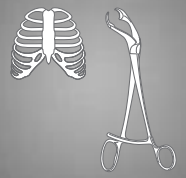

1/2

Liston-Key
23-957-27-07
26 cm / 10 2/8"



1/2

Semb
23-959-24-07
24,5 cm / 9 5/8"

Herz-, Thorax- und Gefäßchirurgie
Cardio Thoracic and Vascular Surgery
Cirugía cardíaca, torácica y vascular
Chirurgie cardiaque, thoracique et vasculaire
Chirurgia cardiaca, toracica e vascolare

24

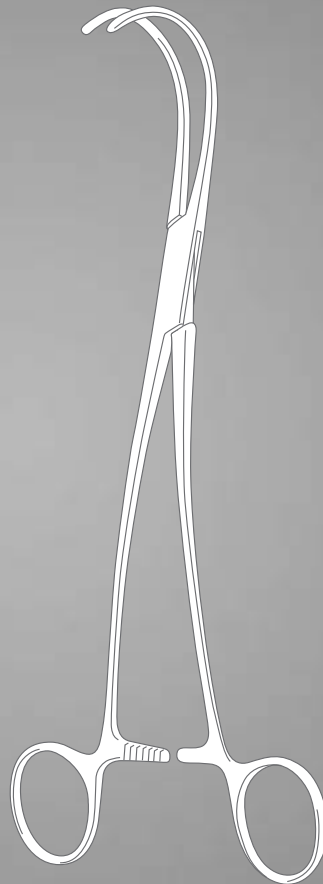
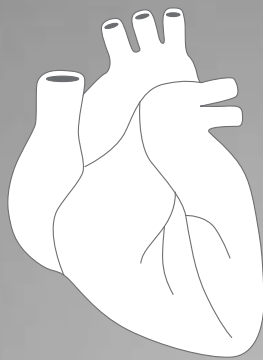

Spezial-Produkte

Special Products

Productos especiales

Produits spéciaux

Prodotti speciali

Unser Ordner-System „Cardiovascular Surgery“ enthält die gesamte Palette der KLS-Martin-Kardiovaskular-Instrumente.

Our folder system “Cardiovascular Surgery” contains the full range of KLS-Martin cardiovascular instruments.

Nuestro sistema de carpetas “Cardiovascular Surgery” incluye la gama completa de instrumentos cardiovasculares de KLS-Martin.

Notre système de dossiers «Cardiovascular Surgery» contient l'ensemble de la palette des instruments cardiovasculaires KLS Martin.

Il nostro sistema di cartelle “Cardiovascular Surgery” contiene tutti gli strumenti per la chirurgia cardiovascolare di KLS Martin.

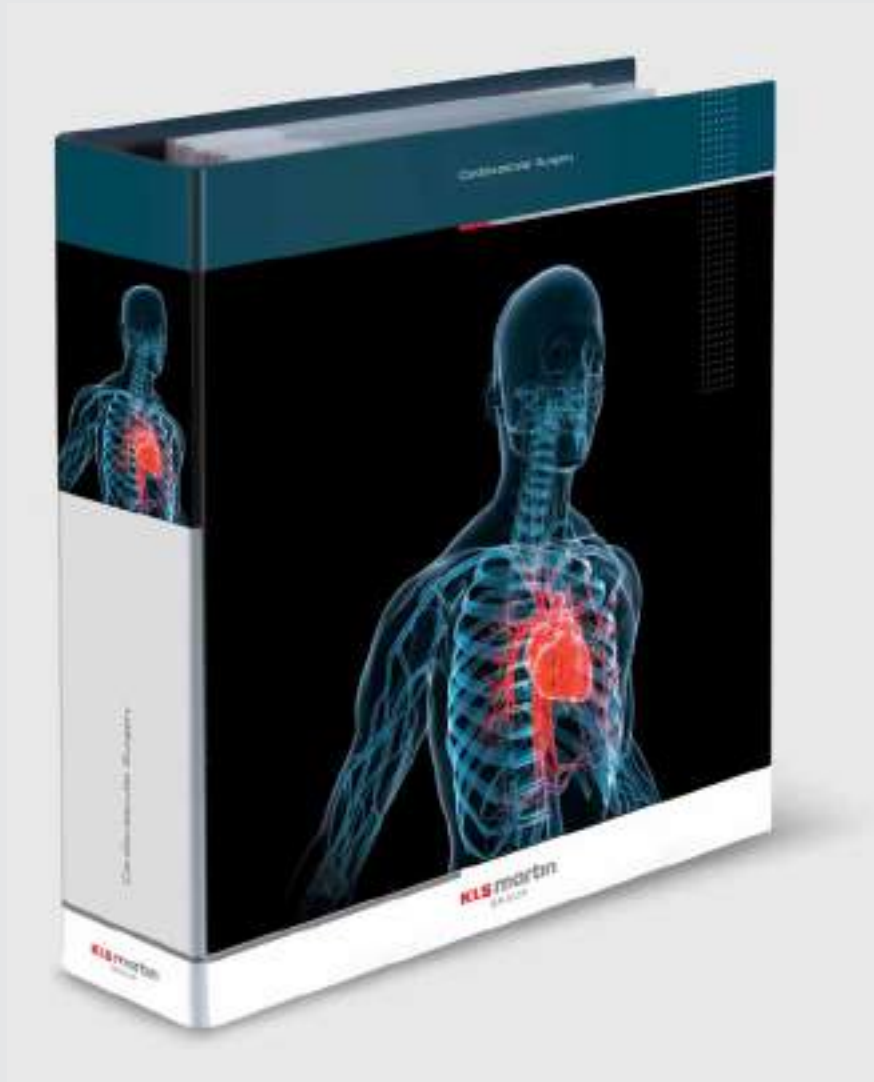
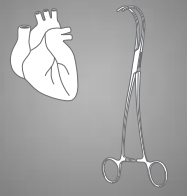

Rippenscheren

Rib Shears
Costótomos
Costotomes
Costotomi



1/2

24-100-23-07

23 cm / 9"

Knochenschere
Bone Shears
Cizallas para hueso
Cisailles à os
Cesoia per ossa



1/2

24-101-22-07

23 cm / 9"



1/2

Gluck
24-107-22-07

21 cm / 8 2/8"

ziehender Schnitt
drawing cut
corte oblicuo
lame glissante
lama di retroazione

Rippenscheren

Rib Shears

Costótomos

Costotomes

Costotomi

Herz-, Thorax- und Gefäßchirurgie

Cardio Thoracic and Vascular Surgery

Cirugía cardíaca, torácica y vascular

Chirurgie cardiaque, thoracique et vasculaire

Chirurgia cardiaca, toracica e vascolare

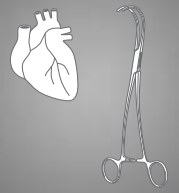

1/2

Bethune
24-126-34-07
34,5 cm / 13 5/8"



1/2

Sauerbruch
24-131-26-07
26 cm / 10 2/8"



1/2

Giertz-Stille
24-137-27-07
24,5 cm / 9 5/8"

Rippenscheren, Sternummeißel

Rib Shears, Sternum Chisel

Costótomos, Cíncel para esternón

Costotomes, Ciseau-burin à sternum

Costotomi, Scalpello per sterno



24-147-28-07

für die rechte Hand
for right hand
para la mano derecha
pour la main droite
per la mano destra

24-149-28-07

für die linke Hand
for left hand
para la mano izquierda
pour la main gauche
per la mano sinistra

1/2

Brunner
24-147-28-07 -
24-149-28-07
32 cm / 12 5/8"

1/2



Lebsche
24-151-24-07
24,5 cm / 9 5/8"

Aortenstanzen, Drainagedurchführzangen

Aortic Punches, Chest Tube Passer
 Perforadores aórticos, Pinza de drenaje
 Rongeurs pour aorte, Pince de drainage
 Pinze taglianti per aorta, Pinze drenaggio

Herz- und Thoraxchirurgie

Cardio Thoracic and Vascular Surgery
 Cirugía cardíaca, torácica y vascular
 Chirurgie cardiaque, thoracique et vasculaire
 Chirurgia cardiaca, toracica e vascolare

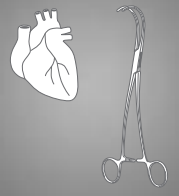

1/2

24-156-01-07 -
 24-156-06-07

15 cm / 5 7/8"

Aortenstanzen
 Aortic punches
 Perforadore aórticos
 Rongeur pour aorte
 Pinza tagliante per aorta



	Ø
24-156-01-07	3,0 mm
24-156-02-07	3,5 mm
24-156-03-07	4,0 mm
24-156-04-07	4,5 mm
24-156-05-07	5,0 mm
24-156-06-07	6,0 mm

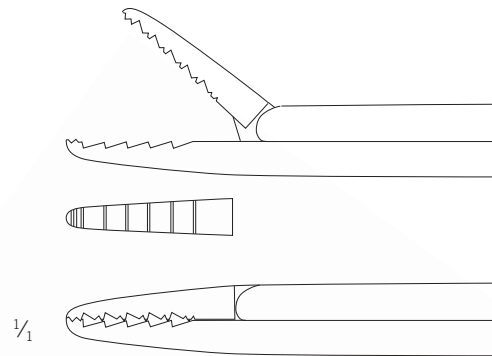

1/2

24-156-24-07 -
 24-157-36-07

	ohne Sperre w/o ratchet sin trinquete sans cran d'arrêt senza arresto	mit Sperre with ratchet con trinquete avec cran d'arrêt con arresto
24 cm / 9 1/8"	24-156-24-07	24-157-24-07
34 cm / 13 3/8"	24-156-36-07	24-157-36-07

Sternum- und Rippensperrer

Sternum and Rib Retractors
 Separadores esternales y costales
 Écarteurs à sternum et des côtes
 Divaricatori per sterno e costali



24-159-02-09
 9 x 20 mm



24-159-03-09
 9 x 10 mm



1/2

24-159-01-09 -
 24-159-03-09

	für Säuglinge for babies para recién nacidos pour nourissons per neonati			
		a x b	c	d
	24-159-02-09	9 x 20 mm	40 mm	52 mm
24-159-03-09	9 x 10 mm			
24-159-01-09 bestehend aus consisting of formado por composé de consistente in		2 Paar Valven (24-159-02-09/-03-09) und Rahmen 2 pairs of blades (24-159-02-09/-03-09) and frame 2 pares de valvas (24-159-02-09/-03-09) y bastidor 2 paires de valves (24-159-02-09/-03-09) et cadre 2 coppie di valve (24-159-02-09/-03-09) e telaio		
		24-159-02-09		
		24-159-03-09		



1/2

Cooley
 24-160-01-04 -
 24-160-02-04

	für Säuglinge for babies para recién nacidos pour nourissons per neonati			
		a x b	c	d
	24-160-01-04	12 x 16 mm	60 mm	95 mm
für Kinder for children para niños pour enfants per bambini				
	a x b	c	d	
24-160-02-04	15 x 30 mm	80 mm	95 mm	

Sternum- und Rippensperrer

Sternum and Rib Retractors
 Separadores esternales y costales
 Écarteurs à sternum et des côtes
 Divaricatori per sterno e costali

Herz-, Thorax- und Gefäßchirurgie

Cardio Thoracic and Vascular Surgery
 Cirugía cardíaca, torácica y vascular
 Chirurgie cardiaque, thoracique et vasculaire
 Chirurgia cardiaca, toracica e vascolare

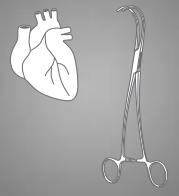

1/2

Cooley
 24-160-03-04 -
 24-160-04-04

AI			
für Kinder for children para niños pour enfants per bambini			
	a x b	c	d
24-160-03-04	20 x 45 mm	100 mm	150 mm
für Erwachsene for adults para adultos pour adultes per adulti			
	a x b	c	d
24-160-04-04	35 x 50 mm	140 mm	180 mm



1/2

Finochietto
 24-161-01-04 -
 24-162-01-04

AI			
für Säuglinge for babies para recién nacidos pour nourissons per neonati			
	a x b	c	d
24-161-01-04	15 x 15 mm	60 mm	75 mm
für Kinder for children para niños pour enfants per bambini			
	a x b	c	d
24-162-01-04	31 x 31 mm	80 mm	100 mm

Sternum- und Rippensperrer

Sternum and Rib Retractors
 Separadores esternales y costales
 Écarteurs à sternum et des côtes
 Divaricatori per sterno e costali

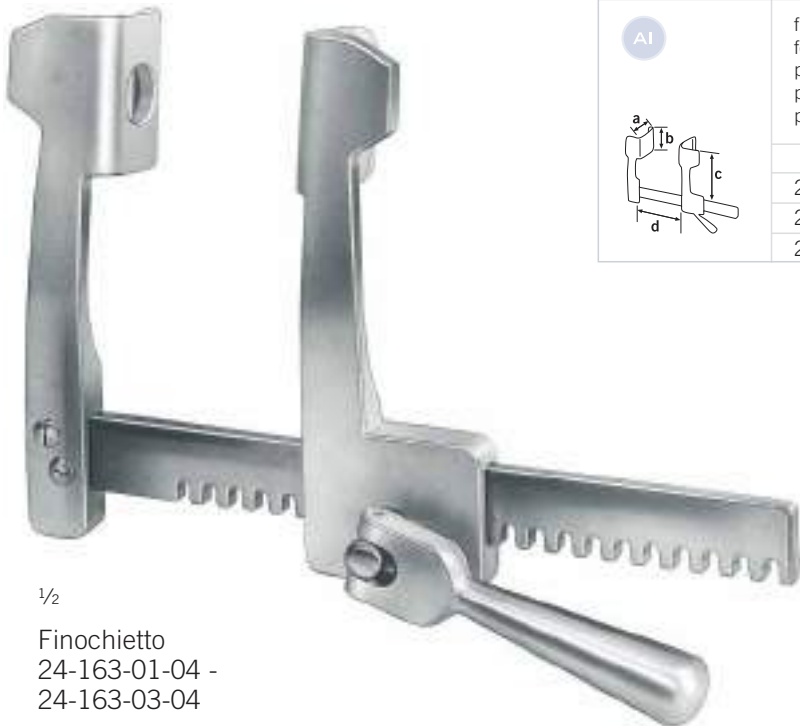

1/2

Finochietto
 24-163-01-04 -
 24-163-03-04

	für Kinder und Erwachsene for children and adults para niños y adultos pour enfants et adultes per bambini e adulti			
		a x b	c	d
	24-163-01-04	40 x 45 mm	105 mm	135 mm
	24-163-02-04	45 x 60 mm	140 mm	175 mm
24-163-03-04	85 x 65 mm	140 mm	175 mm	

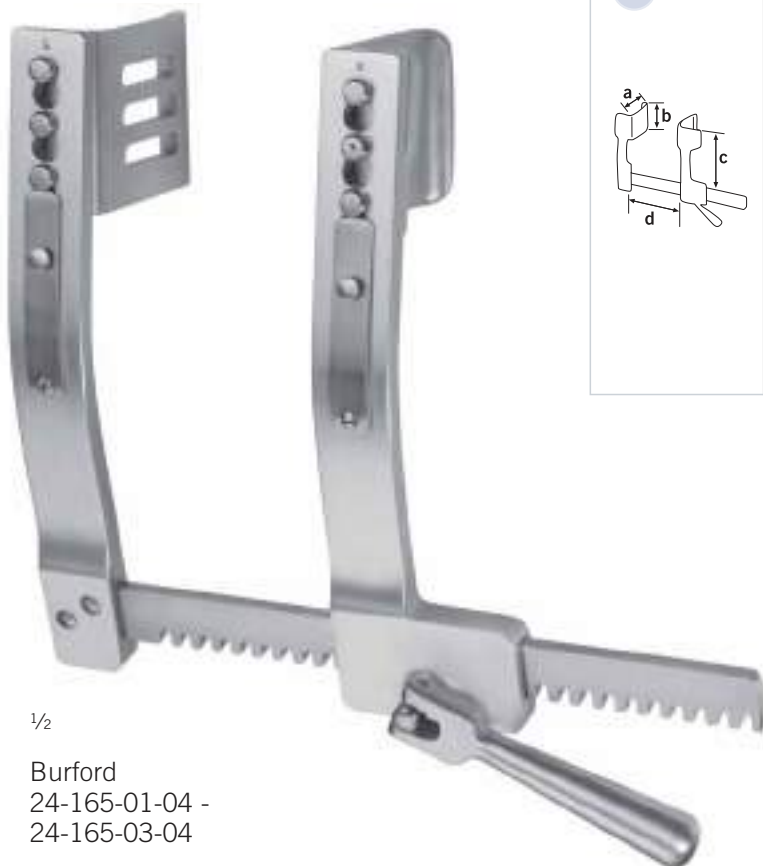

1/2

Burford
 24-165-01-04 -
 24-165-03-04

	für Erwachsene for adults para adultos pour adultes per adulti			
		a x b	c	d
	24-165-01-04	47 x 62 mm	195 mm	165 mm
		62 x 62 mm		
24-165-02-04	47 x 62 mm	195 mm	260 mm	
	62 x 62 mm			
24-165-03-04	47 x 62 mm	195 mm	280 mm	
	62 x 62 mm			



Sternum- und Rippensperrerr

Sternum and Rib Retractors
 Separadores esternales y costales
 Écarteurs à sternum et des côtes
 Divaricatori per sterno e costali

Herz-, Thorax- und Gefäßchirurgie

Cardio Thoracic and Vascular Surgery
 Cirugía cardíaca, torácica y vascular
 Chirurgie cardiaque, thoracique et vasculaire
 Chirurgia cardiaca, toracica e vascolare

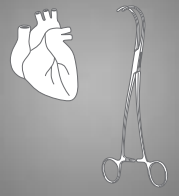

1/2

Castañeda
 24-166-01-04 -
 24-166-03-04

AI			
für Säuglinge for babies para recién nacidos pour nourissons per neonati			
	a x b	c	d
24-166-01-04	10 x 32 mm	60 mm	65 mm
für Säuglinge und Kinder for babies and children para recién nacidos y niños pour nourissons et enfants per neonati e bambini			
	a x b	c	d
24-166-02-04	12 x 45 mm	80 mm	70 mm
für Kinder for children para niños pour enfants per bambini			
	a x b	c	d
24-166-03-04	15 x 60 mm	120 mm	100 mm

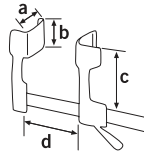

1/2

Finochietto (modif.)
 24-167-01-04

AI			
für Kinder und Erwachsene for children and adults para niños y adultos pour enfants et adultes per bambini e adulti			
	a x b	c	d
24-167-01-04	14 x 15 mm	100 mm	100 mm

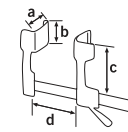

Sternum- und Rippensperrer

Sternum and Rib Retractors

Separadores esternales y costales

Écarteurs à sternum et des côtes

Divaricatori per sterno e costali



1/2

Haight
24-168-90-07

	für Kinder und Erwachsene for children and adults para niños y adultos pour enfants et adultes per bambini e adulti		
	a x b	c	d
24-168-90-07	30 x 30 mm	90 mm	120 mm

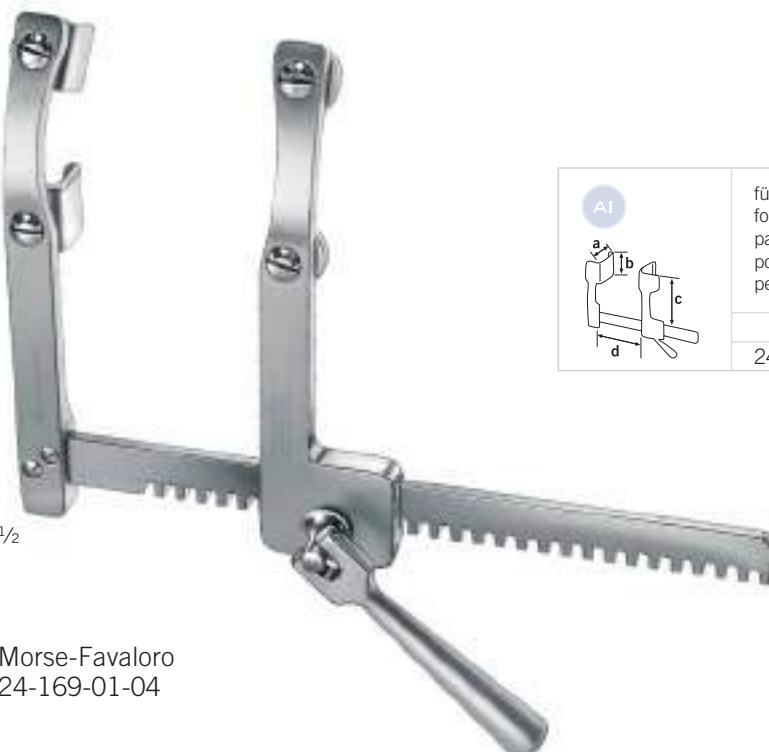

1/2

Morse-Favaloro
24-169-01-04

	für Kinder und Erwachsene for children and adults para niños y adultos pour enfants et adultes per bambini e adulti		
	4 bewegliche Valven 4 adjustable blades 4 valvas móviles 4 valves mobiles 4 valve mobili	a x b	c
24-169-01-04	17 x 22 mm	120 mm	160 mm

Sternum- und Rippensperrerr

Sternum and Rib Retractors
 Separadores esternales y costales
 Écarteurs à sternum et des côtes
 Divaricatori per sterno e costali

Herz-, Thorax- und Gefäßchirurgie

Cardio Thoracic and Vascular Surgery
 Cirugía cardíaca, torácica y vascular
 Chirurgie cardiaque, thoracique et vasculaire
 Chirurgia cardiaca, toracica e vascolare

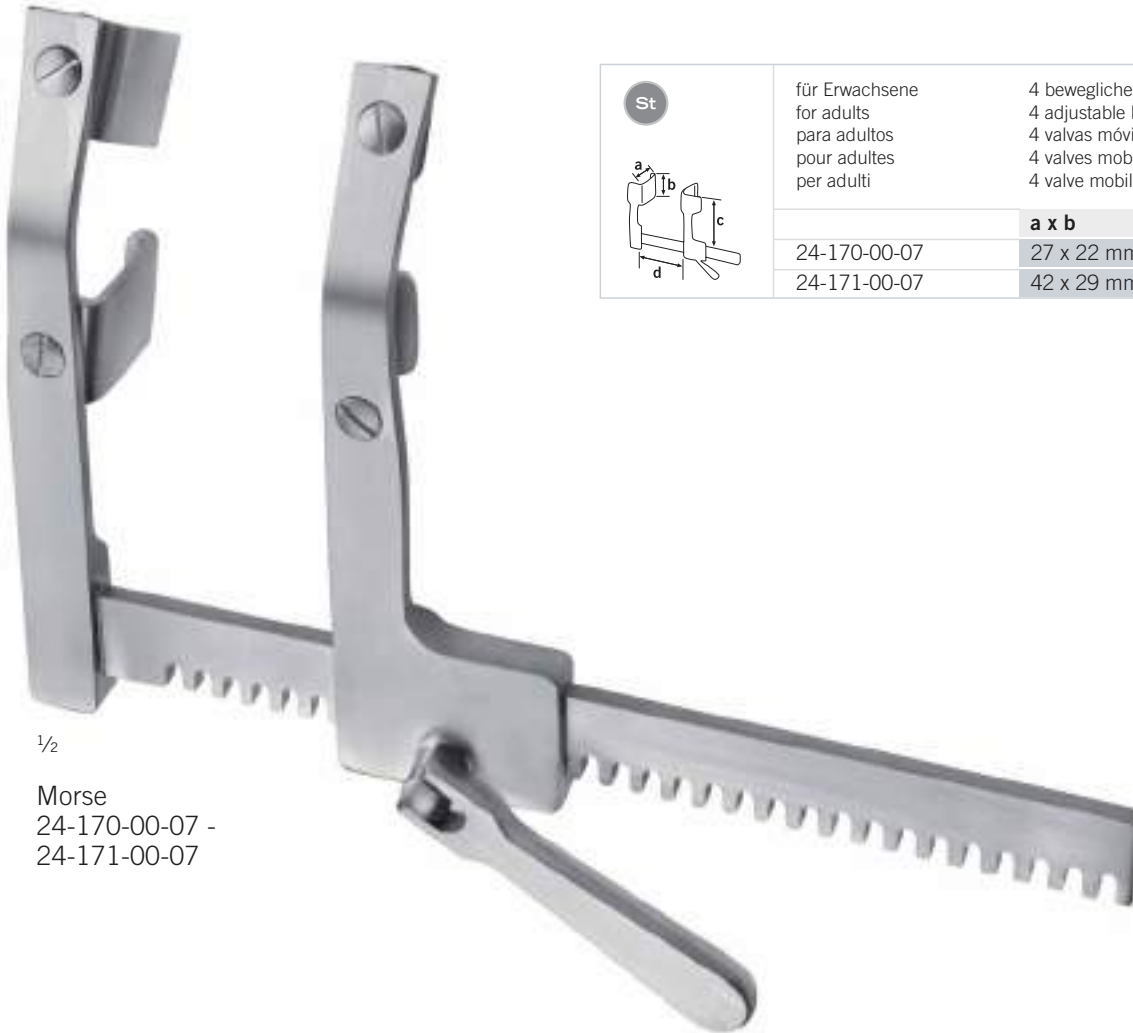
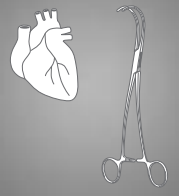

1/2

Morse
 24-170-00-07 -
 24-171-00-07

	für Erwachsene for adults para adultos pour adultes per adulti	4 bewegliche Valven 4 adjustable blades 4 valvas móviles 4 valves mobiles 4 valve mobili		
		a x b	c	d
	24-170-00-07	27 x 22 mm	145 mm	200 mm
24-171-00-07	42 x 29 mm	140 mm	210 mm	



1/2

Tuffier
 24-174-02-07

	für Erwachsene for adults para adultos pour adultes per adulti			
		a x b	c	d
	24-174-02-07	45 x 45 mm	110 mm	170 mm

Sternum- und Rippensperrer

Sternum and Rib Retractors
 Separadores esternales y costales
 Écarteurs à sternum et des côtes
 Divaricatori per sterno e costali



1/2

	für Säuglinge und Kinder for babies and children para recién nacidos y niños pour nourissons et enfants per neonati e bambini		
	a x b	c	d
24-177-75-07	15 x 20 mm	50 mm	75 mm

Finochietto, Baby
24-177-75-07



1/2

	für Erwachsene for adults para adultos pour adultes per adulti		
	a x b	c	d
24-178-01-07	40 x 45 mm	110 mm	150 mm
24-178-02-07	45 x 65 mm	140 mm	165 mm
24-178-03-07	80 x 65 mm	140 mm	190 mm

Finochietto
24-178-01-07 -
24-178-03-07

Sternum- und Rippensperrer

Sternum and Rib Retractors
 Separadores esternales y costales
 Écarteurs à sternum et des côtes
 Divaricatori per sterno e costali

Herz-, Thorax- und Gefäßchirurgie

Cardio Thoracic and Vascular Surgery
 Cirugía cardíaca, torácica y vascular
 Chirurgie cardiaque, thoracique et vasculaire
 Chirurgia cardiaca, toracica e vascolare

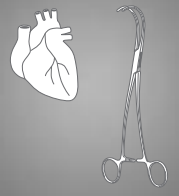

1/3

De Bakey
 24-179-00-07

	für Erwachsene for adults para adultos pour adultes per adulti			
		a x b	c	d
	24-179-00-07	30 x 30 mm 40 x 40 mm 50 x 50 mm	160 mm	150 mm
	bestehend aus consisting of formado por composé de consistente in	3 Paar Valven 3 pairs of blades 3 pares de valvas 3 paires de valves 3 coppie di valve	Rahmen Frame Bastidor Cadre Telaio	
	24-179-02-07 24-179-03-07 24-179-04-07	24-179-01-07		

1/3

De Bakey
 24-179-02-07
30 x 30 mm



De Bakey
 24-179-03-07
40 x 40 mm



De Bakey
 24-179-04-07
50 x 50 mm

Sternum- und Rippensperrer

Sternum and Rib Retractors

Separadores esternales y costales

Écarteurs à sternum et des côtes

Divaricatori per sterno e costali



1/3

De Bakey
24-180-00-07

	für Erwachsene for adults para adultos pour adultes per adulti			
		a x b	c	d
	24-180-00-07	60 x 60 mm 50 x 80 mm 40 x 100 mm	170 mm	200 mm
	bestehend aus consisting of formado por composé de consistente in	3 Paar Valven 3 pairs of blades 3 pares de valvas 3 paires de valves 3 coppie di valve	Rahmen Frame Bastidor Cadre Telaio	
		24-180-02-07	24-180-01-07	
		24-180-03-07		
		24-180-04-07		



1/3

De Bakey
24-180-02-07
60 x 60 mm



De Bakey
24-180-03-07
50 x 80 mm



De Bakey
24-180-04-07
40 x 100 mm



1/3

De Bakey
24-180-05-07
80 x 60 mm



De Bakey
24-180-06-07
50 x 65 mm

Sternum- und Rippensperrer

Sternum and Rib Retractors
 Separadores esternales y costales
 Écarteurs à sternum et des côtes
 Divaricatori per sterno e costali

Herz-, Thorax- und Gefäßchirurgie

Cardio Thoracic and Vascular Surgery
 Cirugía cardíaca, torácica y vascular
 Chirurgie cardiaque, thoracique et vasculaire
 Chirurgia cardiaca, toracica e vascolare

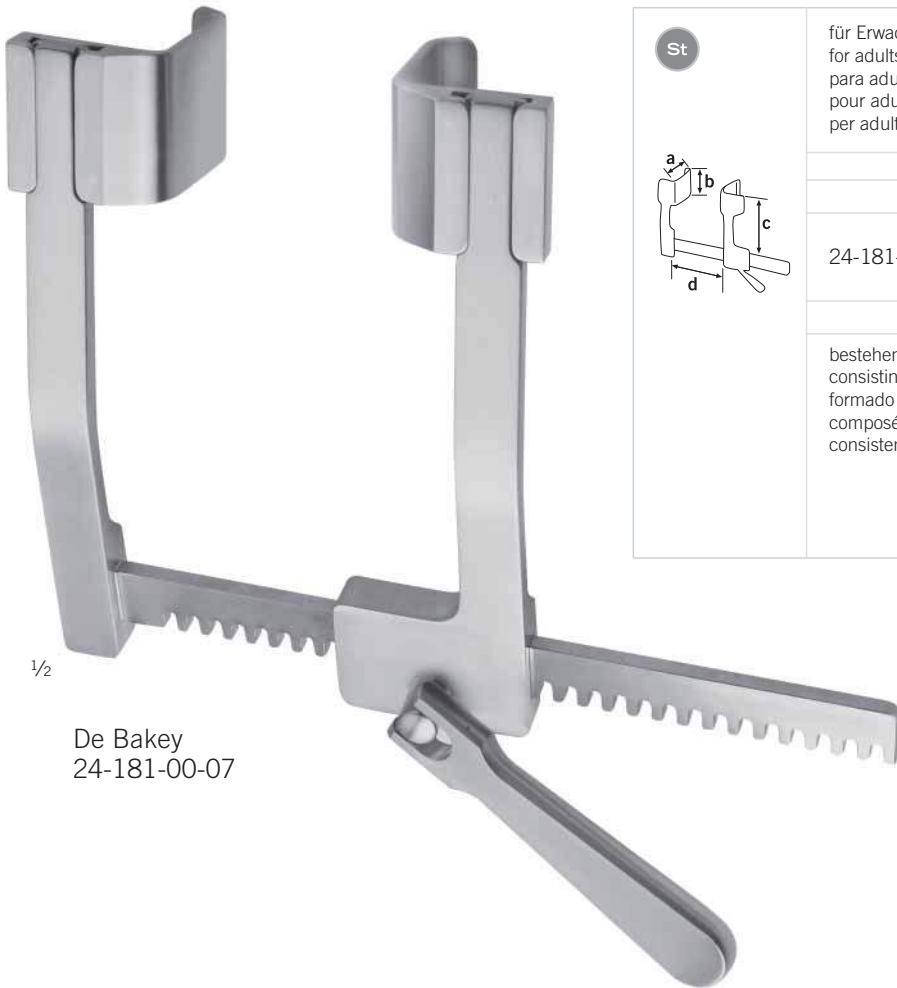
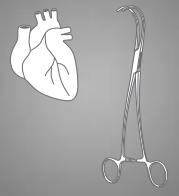

St	für Erwachsene for adults para adultos pour adultes per adulti	Diagram 1		Diagram 2	
		a x b	c	d	
24-181-00-07		30 x 30 mm	145 mm	150 mm	
		40 x 40 mm			
		40 x 40 mm			
bestehend aus consisting of formado por composé de consistente in	3 Paar Valven 3 pairs of blades 3 pares de valvas 3 paires de valves 3 coppie di valve	Rahmen Frame Bastidor Cadre Telaio			
		24-181-02-07			
		24-181-03-07		24-181-01-07	
		24-181-04-07			

1/2

De Bakey
24-181-00-07

1/2

De Bakey
24-181-02-07
30 x 30 mm



De Bakey
24-181-03-07
40 x 40 mm





De Bakey
24-181-04-07
50 x 50 mm

24

Sternum- und Rippensperrer

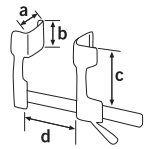
Sternum and Rib Retractors
 Separadores esternales y costales
 Écarteurs à sternum et des côtes
 Divaricatori per sterno e costali

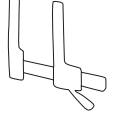
	für Erwachsene for adults para adultos pour adultes per adulti			
		a x b	c	d
	24-182-00-07	60 x 60 mm 50 x 80 mm 40 x 100 mm	190 mm	240 mm
	bestehend aus consisting of formado por composé de consistente in	3 Paar Valven 3 pairs of blades 3 pares de valvas 3 paires de valves 3 coppie di valve	Rahmen Frame Bastidor Cadre Telaio	
		24-182-02-07 24-182-03-07 24-182-04-07	24-182-01-07	



1/2

De Bakey
24-182-00-07

Sternum- und Rippensperrerr

Sternum and Rib Retractors
Separadores esternales y costales
Écarteurs à sternum et des côtes
Divaricatori per sterno e costali

Herz-, Thorax- und Gefäßchirurgie

Cardio Thoracic and Vascular Surgery
Cirugía cardíaca, torácica y vascular
Chirurgie cardiaque, thoracique et vasculaire
Chirurgia cardiaca, toracica e vascolare

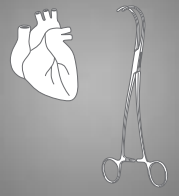

1/2

De Bakey
24-182-02-07
60 x 60 mm



De Bakey
24-182-03-07
50 x 80 mm



1/2

De Bakey
24-182-04-07
40 x 100 mm



De Bakey
24-182-05-07
80 x 60 mm



1/2

De Bakey
24-182-06-07
50 x 65 mm

Sternum- und Rippensperrer

Sternum and Rib Retractors

Separadores esternales y costales

Écarteurs à sternum et des côtes

Divaricatori per sterno e costali

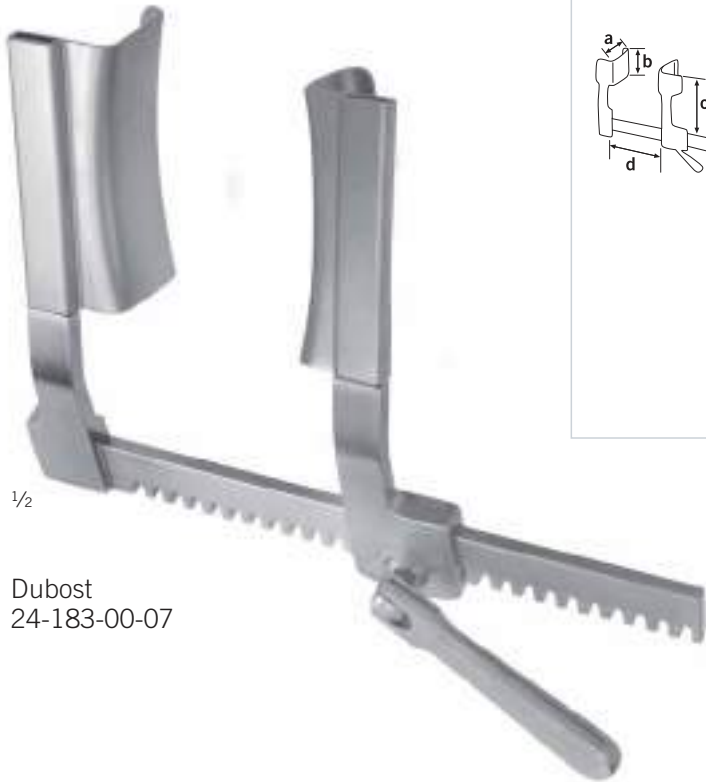

1/2

Dubost
24-183-00-07

	für Erwachsene for adults para adultos pour adultes per adulti			
		a x b	c	d
	24-183-00-07	30 x 100 mm 40 x 100 mm 50 x 100 mm	140 mm	160 mm
	bestehend aus consisting of formado por composé de consistente in	3 Paar Valven 3 pairs of blades 3 pares de valvas 3 paires de valves 3 coppie di valve	Rahmen Frame Bastidor Cadre Telaio	
	24-183-03-07 24-183-04-07 24-183-05-07	24-183-02-07		



1/2

Dubost
24-183-01-07

24-183-01-07			
IMA-Konfiguration IMA configuration Configuración IMA Configuration IMA Configurazione IMA			
bestehend aus consisting of formado por composé de consistente in	3 Paar Valven 3 pairs of blades 3 pares de valvas 3 paires de valves 3 coppie di valve	IMA-Valven IMA blades Valvas IMA Valves IMA Valve IMA	Rahmen Frame Bastidor Cadre Telaio
	24-183-03-07 24-183-04-07 24-183-05-07	24-183-06-07 24-183-07-07	24-183-02-07

Sternum- und Rippensperrer

Sternum and Rib Retractors
Separadores esternales y costales
Écarteurs à sternum et des côtes
Divaricatori per sterno e costali

Herz-, Thorax- und Gefäßchirurgie

Cardio Thoracic and Vascular Surgery
Cirugía cardíaca, torácica y vascular
Chirurgie cardiaque, thoracique et vasculaire
Chirurgia cardiaca, toracica e vascolare

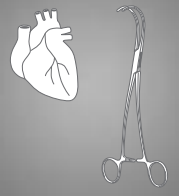

1/2



Dubost
24-183-03-07
30 x 100 mm



Dubost
24-183-04-07
40 x 100 mm



Dubost
24-183-05-07
50 x 100 mm



1/2

Dubost
24-183-06-07
für IMA-Konfiguration
for IMA configuration
para configuración IMA
pour configuration IMA
per configurazione IMA



1/2

Dubost
24-183-07-07
für IMA-Konfiguration
for IMA configuration
para configuración IMA
pour configuration IMA
per configurazione IMA

Sternum- und Rippensperrer

Sternum and Rib Retractors

Separadores esternales y costales

Écarteurs à sternum et des côtes

Divaricatori per sterno e costali

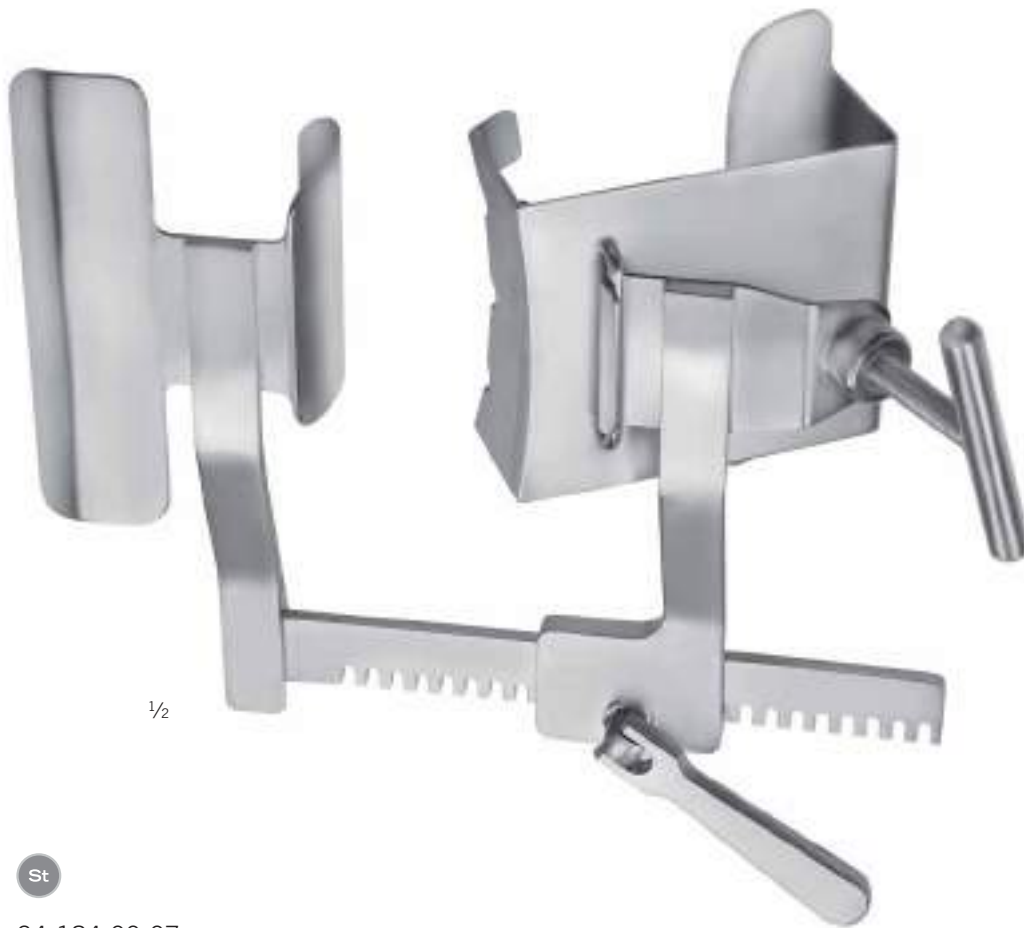

St

24-184-00-07

IMA-Sperrer
IMA retractor
Separador IMA
Rétracteur IMA
Divaricatore IMA

für Erwachsene
for adults
para adultos
pour adultes
per adulti

Sternum- und Rippensperrer

Sternum and Rib Retractors
 Separadores esternales y costales
 Écarteurs à sternum et des côtes
 Divaricatori per sterno e costali

Herz-, Thorax- und Gefäßchirurgie

Cardio Thoracic and Vascular Surgery
 Cirugía cardíaca, torácica y vascular
 Chirurgie cardiaque, thoracique et vasculaire
 Chirurgia cardiaca, toracica e vascolare

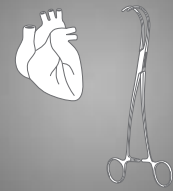

24-185-00-07

Mini-Thorakotomie-Sperrer mit beweglichen Armen und abnehmbarer Querstange
 Mini thoracotomy retractor with adjustable, jointed arms and detachable bar
 Separador mini de toracotomía con brazos articulados y varilla transversal desmontable
 Écarteur mini-thoracotomie à bras mobiles et barre transversale amovible
 Divaricatore mini per toracotomia con bracci mobili e barra trasversale smontabile

	für Erwachsene for adults para adultos pour adultes per adulti			
		a x b	c	d
	24-185-00-07	40 x 36 mm 55 x 36 mm	100 mm	140 mm
	bestehend aus consisting of formado por composé de consistente in	2 Paar Valven 2 pairs of blades 2 pares de valvas 2 paires de valves 2 coppie di valve	Rahmen mit Querstange Frame with bar Bastidor con varilla transversal Cadre avec barre transversale Telaio con barra trasversale	
		24-185-04-07 24-185-05-07	24-185-01-07	



exemplarische Klappenchirurgie-Konfiguration, bestehend aus
 exemplary valve surgery configuration, consisting of
 Configuración ejemplar de cirugía valvular, formado por
 exemple de configuration de chirurgie valvulaire, composé de
 Configurazione esemplare di chirurgia valvolare, composta da

Rahmen mit abnehmbare Querstange Frame with detachable bar Bastidor con varilla transversal desmontable Cadre avec barre transversale amovible Telaio con barra trasversale smontabile	1 Paar Valven 1 pairs of blades 1 pares de valvas 1 paires de valves 1 coppie di valve	Fixierelement Fixation element Elemento de fijación Élément de fixation Elemento di fissaggio	Haken Retractor Retractor Rétracteur Retrattore
24-185-01-07	24-185-04-07	24-187-02-07	24-187-01-07

Sternum- und Rippensperrer

Sternum and Rib Retractors
 Separadores esternales y costales
 Écarteurs à sternum et des côtes
 Divaricatori per sterno e costali

Kein Gewinde, kein Verfangen von Fäden möglich
 No thread, no danger of suture getting caught
 no rosca, no existe peligro de enredo de las suturas
 aucun vis, les fils de suture ne peuvent plus s'emmêler
 no Filettatura, nessun pericolo di impiglio della sutura



24-185-02-07

Mini-Thorakotomie-Sperrer mit beweglichen Armen
 Mini thoracotomy retractor with adjustable, jointed arms
 Separador mini de toracotomía con brazos móviles
 Écarteur mini-thoracotomie à bras mobiles
 Divaricatore mini per toracotomia con bracci mobili

	St für Erwachsene for adults para adultos pour adultes per adulti			
		a x b	c	d
	24-185-02-07	40 x 36 mm 55 x 36 mm	100 mm	140 mm
	bestehend aus consisting of formado por composé de consistente in	2 Paar Valven 2 pairs of blades 2 pares de valvas 2 paires de valves 2 coppie di valve	Rahmen Frame Bastidor Cadre Telaio	
		24-185-04-07 24-185-05-07	24-185-03-07	



1/2

24-185-04-07

40 x 36 mm

➔ 24-185-00-07,
24-185-01-07,
24-185-02-07,
24-185-03-07



1/2

24-185-05-07

55 x 36 mm

➔ 24-185-00-07,
24-185-01-07,
24-185-02-07,
24-185-03-07

Sternum- und Rippensperrer

Sternum and Rib Retractors
 Separadores esternales y costales
 Écarteurs à sternum et des côtes
 Divaricatori per sterno e costali

Herz-, Thorax- und Gefäßchirurgie

Cardio Thoracic and Vascular Surgery
 Cirugía cardíaca, torácica y vascular
 Chirurgie cardiaque, thoracique et vasculaire
 Chirurgia cardiaca, toracica e vascolare

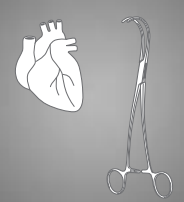

abnehmbarer Griff für ein freies OP-Feld

detachable handle for unobstructed view of the surgical site

mango desmontable para una visión sin obstáculos del campo operatorio

poignée amovible pour un champ opératoire libre

impugnatura smontabile per una visione senza ostruzioni del campo operatorio



kein Verfangen von Fäden möglich durch versunkenes Gewinde für Querstange (24-186-06-07)

no danger of suture getting caught, thanks to recessed threads for cross-bar (24-186-06-07)

no existe peligro de enredo de las suturas gracias a la rosca sumergida para varilla transversal (24-186-06-07)

les fils de suture ne peuvent plus s'emmêler grâce aux vis encastrées pour barre transversale(24-186-06-07)

nessun pericolo di impiglio della sutura grazie a filettatura incassata per barra trasversale (24-186-06-07)

24-186-03-07 -
 24-186-05-07

Mini-Thorakotomie-Sperrer
 Mini thoracotomy retractor
 Separador mini de toracotomía
 Écarteur mini-thoracotomie
 Divaricatore mini per toracotomia

St	a x b	c	d
24-186-03-07	45 x 36 mm	76 mm	85 mm
24-186-04-07	60 x 36 mm	76 mm	85 mm
24-186-05-07	80 x 36 mm	76 mm	85 mm

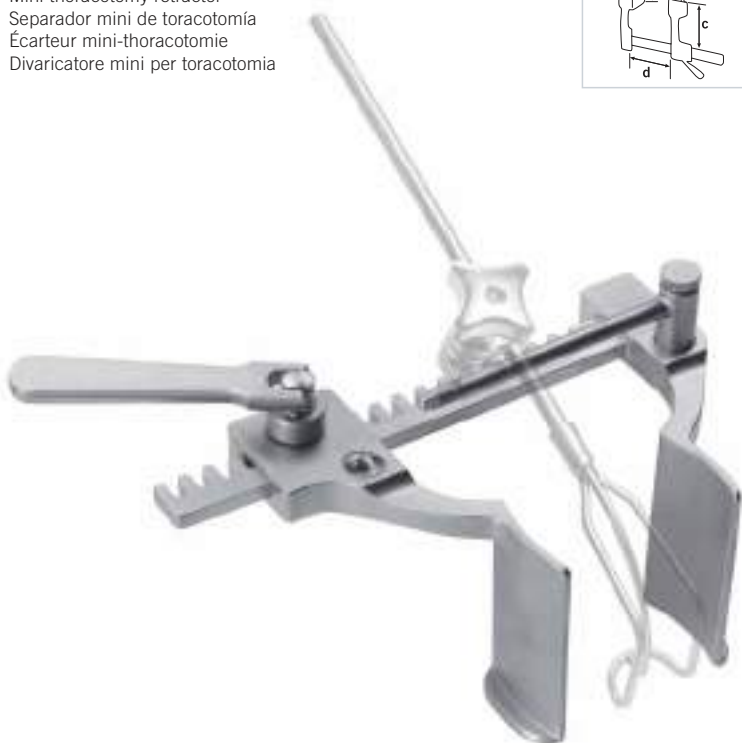
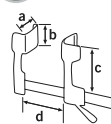

24-186-00-07 -
 24-186-02-07

Mini-Thorakotomie-Sperrer mit abnehmbarer Querstange
 Mini thoracotomy retractor with detachable cross-bar
 Separador mini de toracotomía con varilla transversal desmontable
 Écarteur mini-thoracotomie ave barre transversale amovible
 Mini-divaricatore per toracotomia con barra trasversale asportabile

St	a x b	c	d
24-186-00-07	45 x 36 mm	76 mm	85 mm
24-186-01-07	60 x 36 mm	76 mm	85 mm
24-186-02-07	80 x 36 mm	76 mm	85 mm

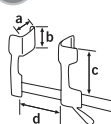

Sternum- und Rippensperrer

Sternum and Rib Retractors

Separadores esternales y costales

Écarteurs à sternum et des côtes

Divaricatori per sterno e costali

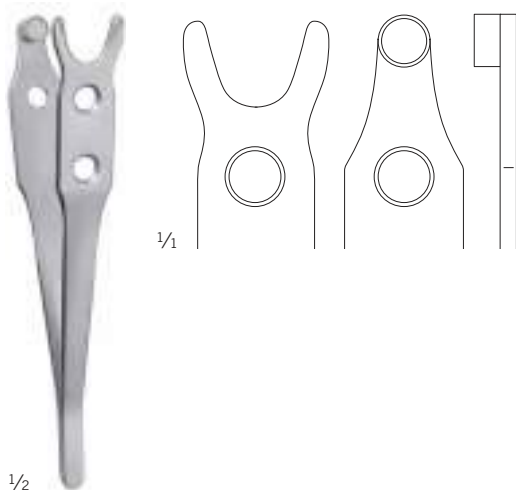

1/2

15-814-99-07

Pinzette zum Austauschen von Valven
Forceps for blade replacement
Pinza para cambiar las valvas
Pince pour remplacer les valves
Pinza per la sostituzione delle valve

→ 24-185-00-07,
24-185-01-07,
24-185-02-07,
24-185-03-07

1/2

24-186-06-07

Querstange
Cross-bar
Varilla transversal
Barre transversale
Barra trasversale

→ 24-185-00-07,
24-185-01-07,
24-186-03-07,
24-186-04-07,
24-186-05-07

Sternum- und Rippensperrer

Sternum and Rib Retractors
Separadores esternales y costales
Écarteurs à sternum et des côtes
Divaricatori per sterno e costali

Herz-, Thorax- und Gefäßchirurgie

Cardio Thoracic and Vascular Surgery
Cirugía cardíaca, torácica y vascular
Chirurgie cardiaque, thoracique et vasculaire
Chirurgia cardiaca, toracica e vascolare

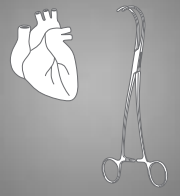

24-187-02-07

Fixierelement
Fixation element
Elemento de fijación
Élément de fixation
Elemento di fissaggio

➔ 24-184-10-07,
24-184-13-07,
24-185-00-07,
24-185-01-07,
24-186-03-07,
24-186-04-07,
24-186-05-07,
24-186-06-07



24-187-05-07

Haken, biegsam
Retractor, malleable
Retractor, maleable
Rétracteur, flexible
Re trattore, flessibile

➔ 24-184-10-07,
24-184-13-07,
24-185-00-07,
24-185-01-07,
24-186-03-07,
24-186-04-07,
24-186-05-07,
24-186-06-07

Sternum- und Rippensperrer

Sternum and Rib Retractors

Separadores esternales y costales

Écarteurs à sternum et des côtes

Divaricatori per sterno e costali



1/2

Cooley
24-187-01-07 -
24-187-04-07

Haken
Retractor
Retractor
Rétracteur
Reattore



24-184-10-07,
24-184-13-07,
24-185-00-07,
24-185-01-07,
24-186-00-07,
24-186-01-07,
24-186-02-07,
24-186-03-07,
24-186-04-07,
24-186-05-07,
24-186-06-07

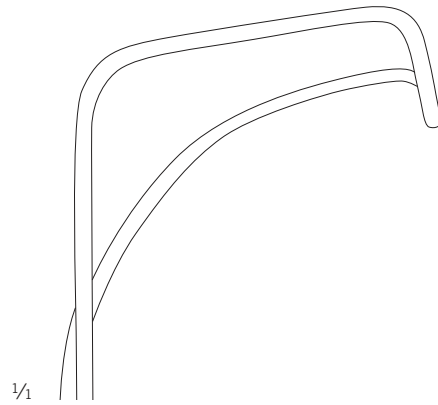

1/4

24-187-01-07

35 x 25 mm

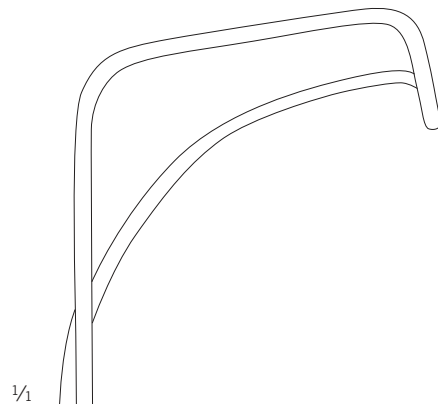
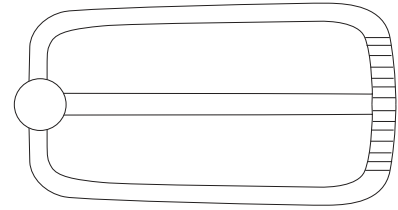

1/4

24-187-03-07

40 x 36 mm

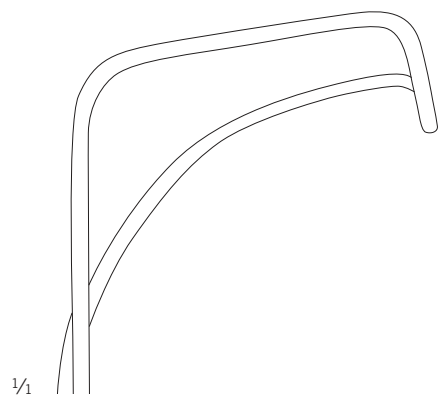
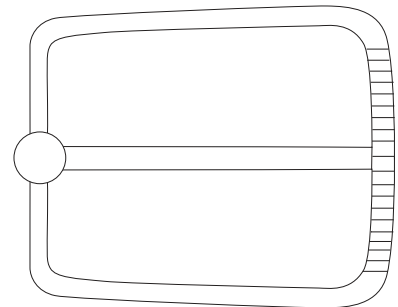

1/4

24-187-04-07

50 x 36 mm

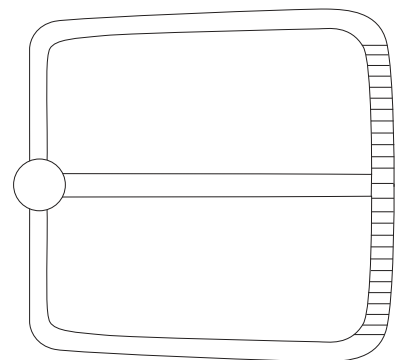

Sternum- und Rippensperrer

Sternum and Rib Retractors
 Separadores esternales y costales
 Écarteurs à sternum et des côtes
 Divaricatori per sterno e costali

Herz-, Thorax- und Gefäßchirurgie

Cardio Thoracic and Vascular Surgery
 Cirugía cardíaca, torácica y vascular
 Chirurgie cardiaque, thoracique et vasculaire
 Chirurgia cardiaca, toracica e vascolare

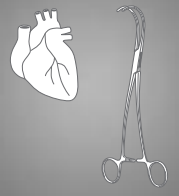

French IMA
 24-188-00-07



24-188-02-07

IMA-Valve, french
 IMA blade, french
 Valva IMA, francesa
 Valve IMA, française
 Valva IMA, francese

30 x 100 mm

24-188-00-07

St

French-IMA-Konfiguration
 French IMA configuration
 Configuración IMA francesa
 Configuration IMA française
 Configurazione IMA francese

bestehend aus
 consisting of
 formado por
 composé de
 consistente in

3 Valven
 3 blades
 3 valvas
 3 valves
 3 alve

Rahmen
 Frame
 Bastidor
 Cadre
 Telaio

24-188-02-07

24-188-03-07

24-188-04-07

24-188-01-07



24-188-03-07

IMA-Valve, french
 IMA blade, french
 Valva IMA, francesa
 Valve IMA, française
 Valva IMA, francese

50 x 22 mm



24-188-04-07

IMA-Valve, french
 IMA blade, french
 Valva IMA, francesa
 Valve IMA, française
 Valva IMA, francese

40 x 22 mm

Sternumsperrer marGate

Sternum Retractors marGate
 Separadores esternales marGate
 Écarteurs à sternum marGate
 Divaricatori per sterno marGate

Exposure, stability and flexibility *Perfection for valve and bypass surgery*



Features marGate

- Ausgezeichnete Exposition des OP-Feldes
- Schneller Valvenwechsel mit nur einem Handgriff
- Kompatibel für Nahthalterschübe
- Besonders flaches Design für mehr Übersicht
- Einfaches und schnelles Rastprinzip über das Fixierelement

marGate features

- Outstanding exposure of the surgical field
- Fast valve replacement with just a single movement
- Compatible with suture holding inserts
- Particularly flat design for more overview
- Simple and fast locking via the attachment element

Características marGate

- Excelente exposición del campo quirúrgico
- Cambio rápido de las valvas con una sola maniobra
- Compatible con insertos de sujeción para suturas
- Diseño particularmente plano para mayor vista general
- Enclavamiento sencillo y rápido a través del elementode fijación

Caractéristiques marGate

- Exposition exceptionnelle du champ opératoire
- Changement rapide de valve avec un geste seulement
- Compatible avec les inserts pour dispositifs de rétention des sutures
- Design particulièrement plat pour davantage de visibilité
- Principe de serrage simple et rapide sur l'élément de fixation

Caratteristiche di marGate

- Esposizione straordinaria del campo operatorio
- Rapida sostituzione delle valvole con una sola presa
- Compatibile per inserti di tenuta della sutura
- Design particolarmente piatto per una maggiore visibilità
- Principio d'arresto semplice e rapido tramite l'elemento di fissaggio

	St 24-189-00-07			
		a x b	c	d
		30 x 100 mm	225 mm	200 mm
	bestehend aus consisting of formado por composé de consistente in	1 Paar Valven 1 pairs of blades 1 pares de valvas 1 paires de valves 1 coppie di valve	Rahmen Frame Bastidor Cadre Telaio	
		24-189-02-07	24-189-01-07	

Sternumsperrer marGate

Sternum Retractors marGate
Separadores esternales marGate
Écarteurs à sternum marGate
Divaricatori per sterno marGate

Herz-, Thorax- und Gefäßchirurgie

Cardio Thoracic and Vascular Surgery
Cirugía cardíaca, torácica y vascular
Chirurgie cardiaque, thoracique et vasculaire
Chirurgia cardiaca, toracica e vascolare

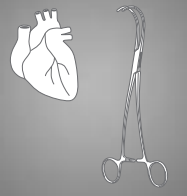

24-189-01-07

Rahmen allein
Frame only
Bastidor suelto
Cadre seul
Telaio solo



1/2

24-189-02-07
30 x 100 mm



24-189-03-07
40 x 100 mm



1/2

24-189-04-07
30 x 28 mm



24-189-05-07
40 x 28 mm

➔ 24-189-00-07,
24-189-01-07

Zubehör für Sternumsperrer marGate

Accessories for Sternum Retractors marGate

Accesorios para separadores esternales marGate

Accessoires pour écarteurs à sternum marGate

Accessori per sterno marGate



1/1

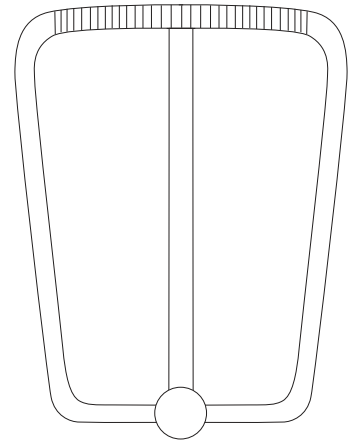
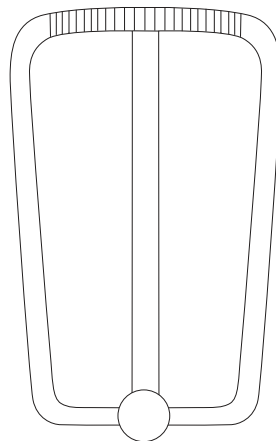
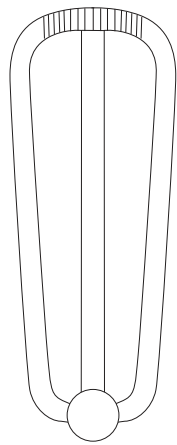

	60 x 20 mm	60 x 35 mm	60 x 45 mm
St	24-189-10-07	24-189-11-07	24-189-12-07
Nit	24-189-10-04	24-189-11-04	24-189-12-04



1/2

Cooley
24-189-10-04 -
24-189-12-07

Atriumhaken, biegsam
Atrium retractor, malleable
Retractor auricular, maleable
Rétracteur atrium, flexible
Retratore atrio, flessibile

➔ 24-189-00-07,
24-189-01-07

24-189-09-07

Fixierelement
Fixation element
Elemento de fijación
Élément de fixation
Elemento di fissaggio

➔ 24-189-00-07,
24-189-01-07

Zubehör für Sternumsperrer marGate Herz-, Thorax- und Gefäßchirurgie

Accessories for Sternum Retractors marGate

Accesorios para separadores esternales marGate

Accessoires pour écarteurs à sternum marGate

Accessori per sterno marGate

Cardio Thoracic and Vascular Surgery

Cirugía cardíaca, torácica y vascular

Chirurgie cardiaque, thoracique et vasculaire

Chirurgia cardiaca, toracica e vascolare

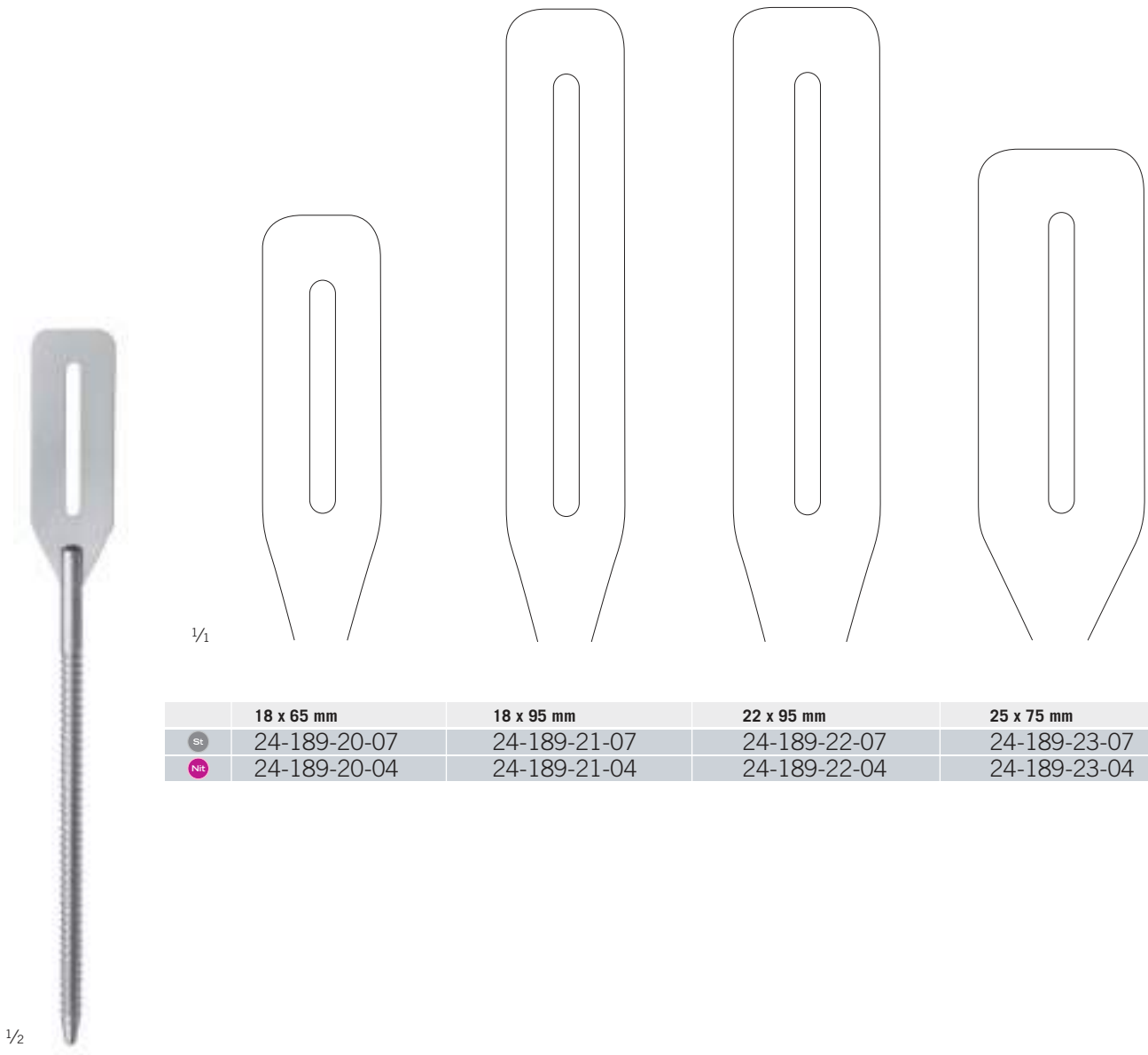
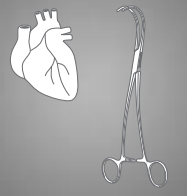

	18 x 65 mm	18 x 95 mm	22 x 95 mm	25 x 75 mm
St	24-189-20-07	24-189-21-07	24-189-22-07	24-189-23-07
NiTi	24-189-20-04	24-189-21-04	24-189-22-04	24-189-23-04

24-189-20-04 -
24-189-23-07

Klappenhaken, biegsam
Valve retractor, malleable
Retractor valvular, maleable
Rétracteur valves, flexible
Retrattore valvola, flessibile

➔ 24-189-00-07,
24-189-01-07

Rippenkontraktoren

Rib Contractors

Aproximadores para costillas

Rapprocheurs des côtes

Approssimatori costali



Sellers
24-218-19-07
20 cm / 7 7/8"

bewegliche Valven
adjustable blades
valvas móviles
valves mobiles
valve mobili



Bailey-Baby
24-220-14-07
15,5 cm / 6 1/8"



Bailey
24-224-16-07
20 cm / 7 7/8"

kurze Klauen
short claws
garras cortas
bras courts
pinze corte



Bailey-Gibbon
24-226-16-07
20 cm / 7 7/8"

lange Klauen
long claws
garras largas
bras longs
pinze lunghe

Wundspreizer

Wound Spreaders, self-retaining

Retradores autoestáticos

Écarteurs autostatiques

Reattori autostatici

Herz-, Thorax- und Gefäßchirurgie

Cardio Thoracic and Vascular Surgery

Cirugía cardíaca, torácica y vascular

Chirurgie cardiaque, thoracique et vasculaire

Chirurgia cardiaca, toracica e vascolare

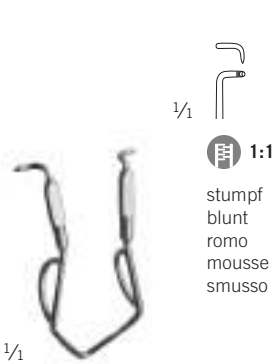
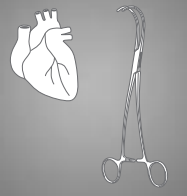

24-230-02-07

2,5 cm / 1"

Koronarfettspreizer

Epicardial spring retractor

Retractor de grasa para cirugía coronaria

Écarteur pour graisse

Reattore di grasso per chirurgia coronarica

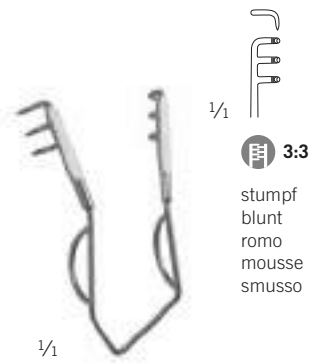

24-230-03-07

3,5 cm / 1 3/8"

Koronarfettspreizer

Epicardial spring retractor

Retractor de grasa para cirugía coronaria

Écarteur pour graisse

Reattore di grasso per chirurgia coronarica

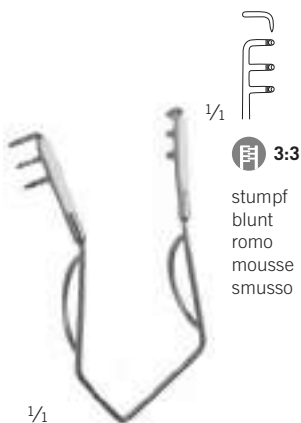

24-230-04-07

4 cm / 1 5/8"

Koronarfettspreizer

Epicardial spring retractor

Retractor de grasa para cirugía coronaria

Écarteur pour graisse

Reattore di grasso per chirurgia coronarica

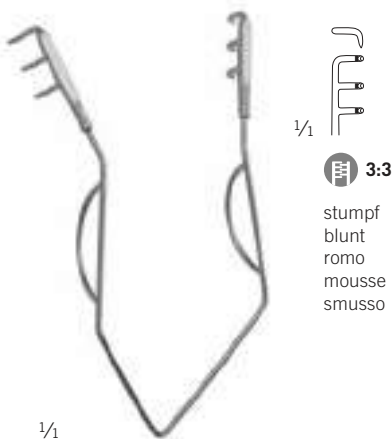

24-230-05-07

5,5 cm / 2 3/8"

Koronarfettspreizer

Epicardial spring retractor

Retractor de grasa para cirugía coronaria

Écarteur pour graisse

Reattore di grasso per chirurgia coronarica

Lungenspatel

Lung Spatulas

Espátulas pulmonares

Spatules pulmonaires

Spatole per pulmone



24-231-30-01

29,5 cm / 11 5/8"

Arbeitsteil schmal

Working part, narrow

Elemento de trabajo, estrecha

Élément de travail, étroit

Elemento di lavoro, stretto

24-231-32-01

33 cm / 13"

Arbeitsteil breit

Working part, wide

Elemento de trabajo, ancha

Élément de travail, large

Elemento di lavoro, largo

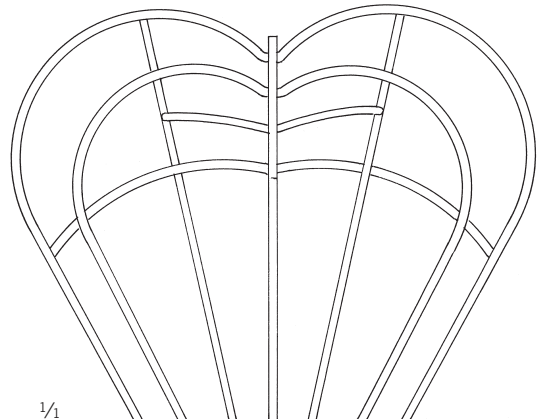

1/2

1/2

Allison
24-231-30-01 -
24-231-32-01

24-233-30-07
29,5 cm / 11 5/8"

Bronchusklemmen

Bronchus Clamps
Pinzas bronquiales
Pince-clamps à bronches
Pinze per bronchi

Herz-, Thorax- und Gefäßchirurgie

Cardio Thoracic and Vascular Surgery
Cirugía cardíaca, torácica y vascular
Chirurgie cardiaque, thoracique et vasculaire
Chirurgia cardiaca, toracica e vascolare

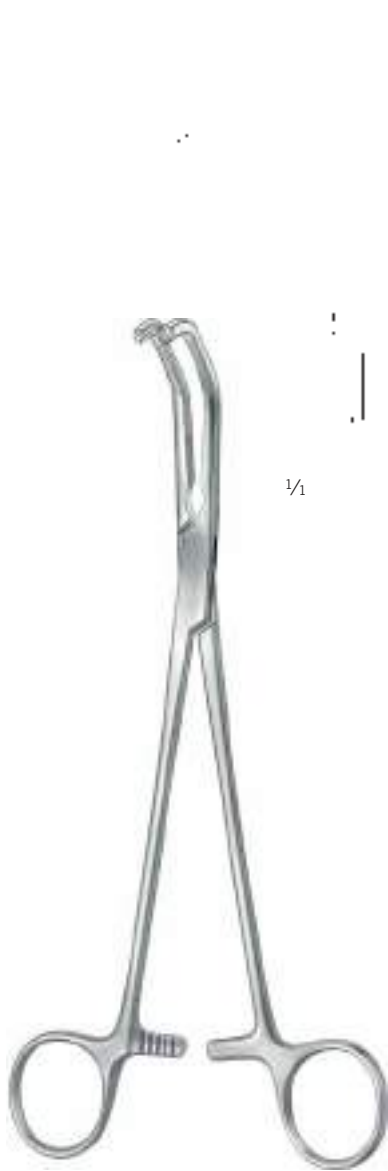
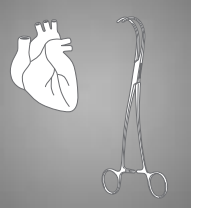

Price-Thomas
24-241-22-07
22 cm / 8 5/8"



Price-Thomas
24-245-22-07 -
24-247-22-07
22 cm / 8 5/8"

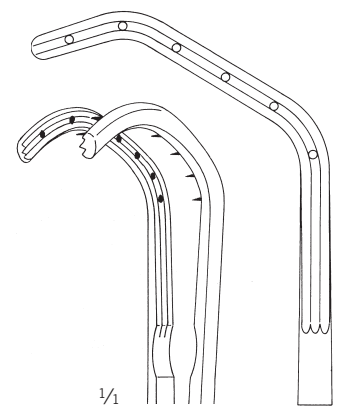

Fig. 2
24-247-22-07

Bronchusklemmen

Bronchus Clamps

Pinzas bronquiales

Pince-clamps à bronches

Pinze per bronchi

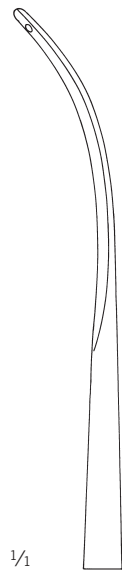

1/1

24-265-24-07

25 cm / 9 7/8"

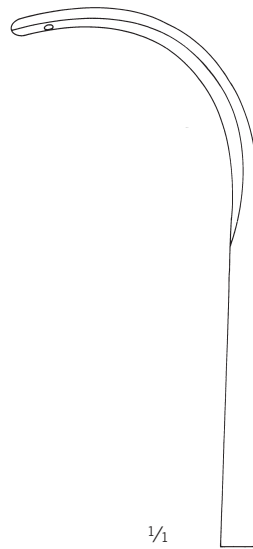

1/1

24-267-24-07

24,5 cm / 9 5/8"

1/2

Semb
24-265-24-07 -
24-267-24-07

Shunt-Bulldogklemmen

Shunt Bulldog Clamps
 Pinzas Bulldog para shunt
 Pincas Bulldog pour carotide
 Pinze Bulldog per shunt

Herz-, Thorax- und Gefäßchirurgie

Cardio Thoracic and Vascular Surgery
 Cirugía cardíaca, torácica y vascular
 Chirurgie cardiaque, thoracique et vasculaire
 Chirurgia cardiaca, toracica e vascolare

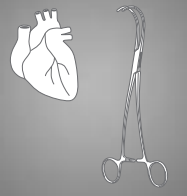

Ti

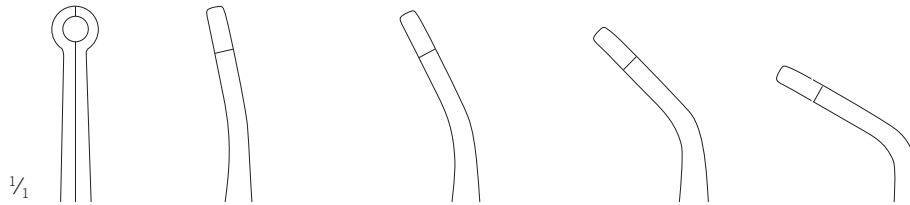

Ø 10 Fr.	24-280-10-09	24-280-25-09	24-280-45-09	24-280-60-09
	10°	25°	45°	60°
	7,5 cm / 3"	7,5 cm / 3"	7 cm / 2 5/8"	6,5 cm / 2 1/8"

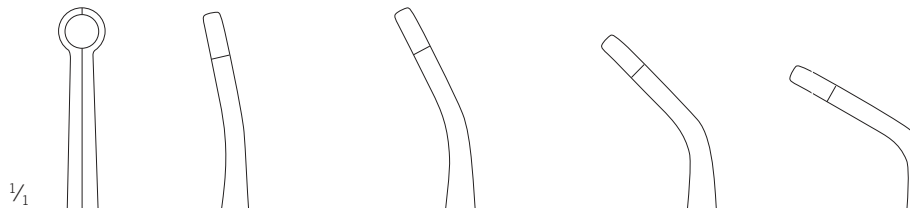

Ø 12 Fr.	24-281-10-09	24-281-25-09	24-281-45-09	24-281-60-09
	10°	25°	45°	60°
	7,5 cm / 3"	7,5 cm / 3"	7 cm / 2 5/8"	6,5 cm / 2 1/8"



1/2

24-280-10-09 -
24-282-60-09

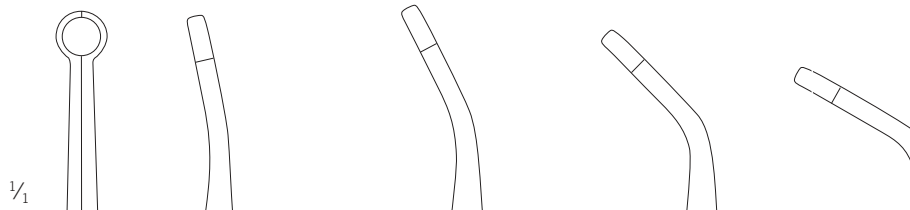

Ø 14 Fr.	24-282-10-09	24-282-25-09	24-282-45-09	24-282-60-09
	10°	25°	45°	60°
	7,5 cm / 3"	7,5 cm / 3"	7 cm / 2 5/8"	6,5 cm / 2 1/8"

24

Lungenfasszangen

Lung Grasping Forceps
Pinzas para coger el pulmón
Pince-clamps à poumons
Pinze per afferrare polmone

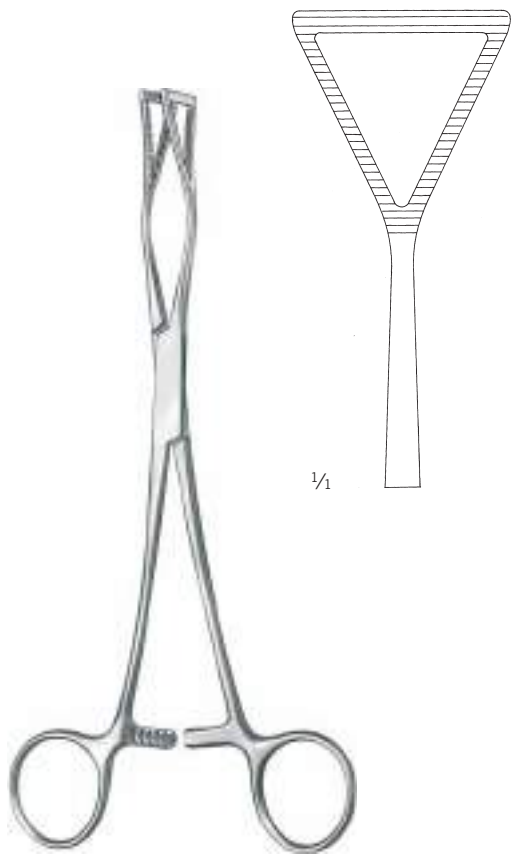

Lovelace
24-286-20-07
20,5 cm / 8 1/8"

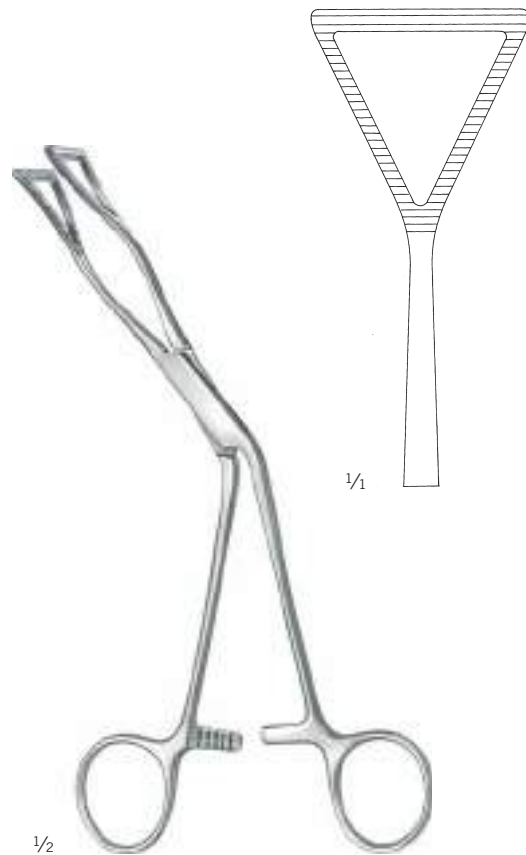

Lovelace
24-287-20-07
19 cm / 7 4/8"

Bulldogklemmen

Bulldog Clamps
Clamps Bulldog
Clamps Bulldog
Pinze Bulldog

Herz-, Thorax- und Gefäßchirurgie

Cardio Thoracic and Vascular Surgery
Cirugía cardíaca, torácica y vascular
Chirurgie cardiaque, thoracique et vasculaire
Chirurgia cardiaca, toracica e vascolare

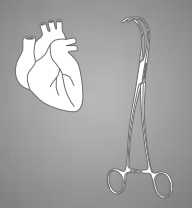

Atrauma



1/2

De Bakey
24-392-07-07 -
24-392-12-07



1/2

De Bakey
24-288-07-09 -
24-288-10-09

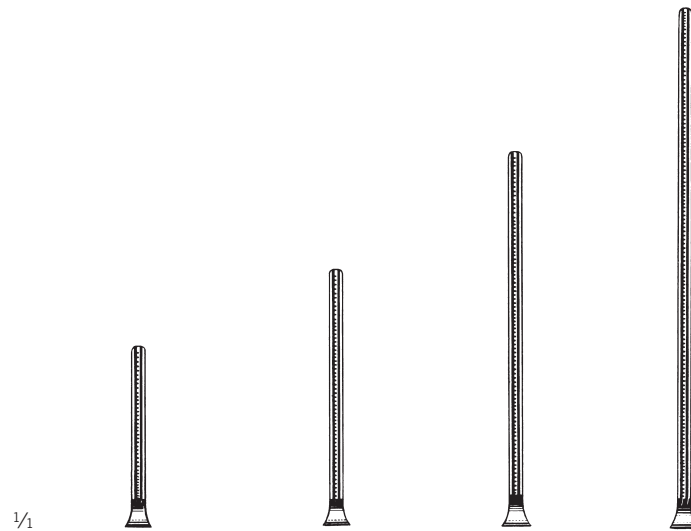

1/4

St	24-392-07-07	24-392-08-07	24-392-10-07	24-392-12-07
Length	8 cm / 3 1/8"	9 cm / 3 4/8"	10,5 cm / 4 1/8"	12,5 cm / 4 7/8"
Width	30 mm	40 mm	55 mm	75 mm

Ti	24-288-07-09	24-288-08-09	24-288-09-09	24-288-10-09
Length	8 cm / 3 1/8"	9 cm / 3 4/8"	11 cm / 4 3/8"	13 cm / 5 1/8"
Width	25 mm	35 mm	55 mm	75 mm



1/2

De Bakey
24-393-07-07 -
24-393-12-07



1/2

De Bakey
24-289-07-09 -
24-289-10-09

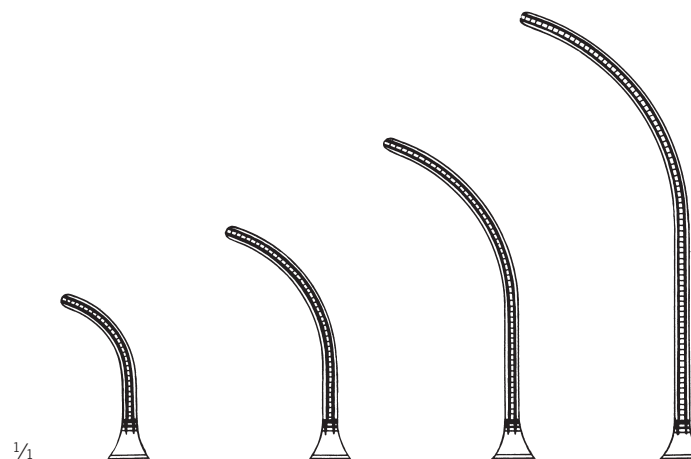

1/4

St	24-393-07-07	24-393-08-07	24-393-10-07	24-393-12-07
Length	8 cm / 3 1/8"	8,5 cm / 3 3/8"	9,5 cm / 3 5/8"	11,5 cm / 4 4/8"
Width	25 mm	35 mm	50 mm	65 mm

Ti	24-289-07-09	24-289-08-09	24-289-09-09	24-289-10-09
Length	8 cm / 3 1/8"	9 cm / 3 4/8"	10 cm / 3 7/8"	11,5 cm / 4 4/8"
Width	25 mm	30 mm	45 mm	60 mm

Bulldogklemmen

Bulldog Clamps

Clamps Bulldog

Clamps Bulldog

Pinze Bulldog

Atrauma

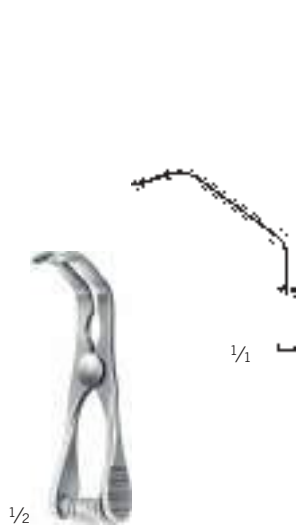

De Bakey-Satinsky
24-291-07-07
7 cm / 2 5/8"

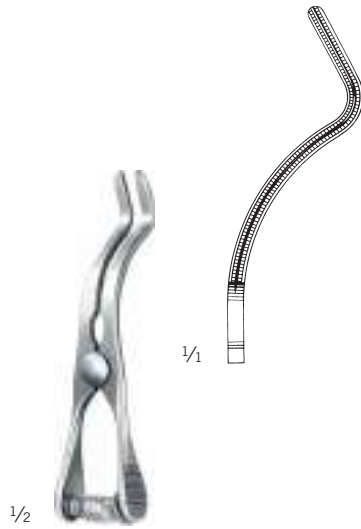

De Bakey-Satinsky
24-291-09-07
9 cm / 3 4/8"



De Bakey-Satinsky
24-291-10-07
10 cm / 3 7/8"



Glover
24-293-06-07
6,5 cm / 2 4/8"



Santulli
24-295-07-07
7 cm / 2 5/8"

Bulldogklemmen

Bulldog Clamps
Clamps Bulldog
Clamps Bulldog
Pinze Bulldog

Herz-, Thorax- und Gefäßchirurgie

Cardio Thoracic and Vascular Surgery
Cirugía cardíaca, torácica y vascular
Chirurgie cardiaque, thoracique et vasculaire
Chirurgia cardiaca, toracica e vascolare

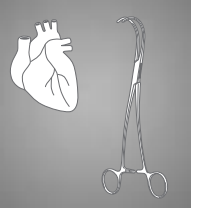

Atrauma



1/2

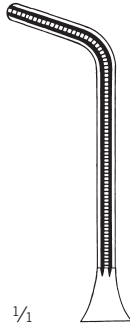

1/1

24-297-09-07

9 cm / 3 4/8"

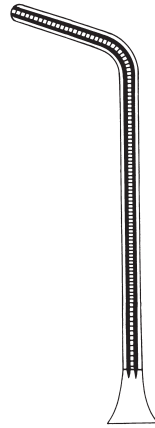

24-297-11-07

11 cm / 4 3/8"

Gregory, soft

24-297-09-07 -
24-297-11-07

Carotis-Bulldogklemme
Carotid clamp
Clamp para carotis
Pince pour carotide
Pinza carotis



1/2

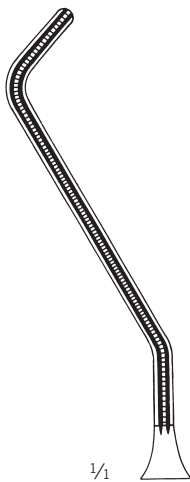

1/1

24-299-01-07

11 cm / 4 3/8"

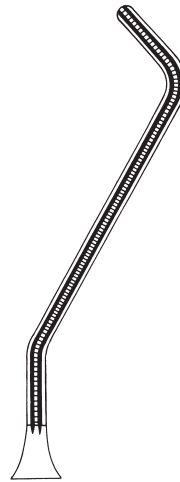

24-299-02-07

11 cm / 4 3/8"

Gregory

24-299-01-07 -
24-299-02-07

Carotis-Bulldogklemme
Carotid clamp
Clamp para carotis
Pince pour carotide
Pinza carotis

Arterienklemmen

Haemostatic Forceps
Pinzas hemostáticas
Pincas hémostatiques
Pinze emostatiche

Atrauma



1/2

De Bakey-Rankin
24-300-16-07 -
24-301-16-07
16 cm / 6 2/8"

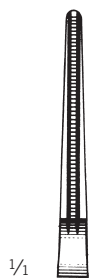

1/1

24-300-16-07



24-301-16-07



1/2

De Bakey-Mosquito
24-302-15-07 -
24-303-15-07
15 cm / 5 7/8"

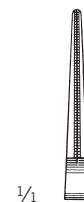

1/1

24-302-15-07

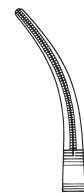

24-303-15-07

Aortaklemmen

Aortic Clamps
Pinzas aórticas
Pincers-clamps pour aorte
Pinze per aorta

Herz-, Thorax- und Gefäßchirurgie

Cardio Thoracic and Vascular Surgery
Cirugía cardíaca, torácica y vascular
Chirurgie cardiaque, thoracique et vasculaire
Chirurgia cardiaca, toracica e vascolare

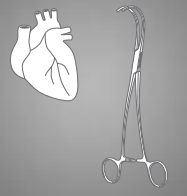

Atrauma



Ochsner
24-317-23-07
22 cm / 8 5/8"



Diethrich
24-319-21-07
21 cm / 8 2/8"

Mehrzweck-Gefäßklemmen

Multi purpose Vascular Clamps
 Pinzas vasculares de usos múltiples
 Pincas vasculaires universelles
 Pinze vascolari universali

Atrauma



1/1

24-336-00-07	15° 24-336-15-07	30° 24-336-30-07	45° 24-336-45-07	90° 24-336-90-07
16 cm / 6 2/8"	15,5 cm / 6 1/8"	15,5 cm / 6 1/8"	15 cm / 5 7/8"	13,5 cm / 5 3/8"



1/1

24-338-00-07	15° 24-338-15-07	30° 24-338-30-07	45° 24-338-45-07	90° 24-338-90-07
17 cm / 6 6/8"	16,5 cm / 6 4/8"	16 cm / 6 2/8"	16 cm / 6 2/8"	14 cm / 5 4/8"



1/2

Dardik
 24-336-00-07 -
 24-338-90-07

Peripheral-Gefäßklemmen

Peripheral Vascular Clamps
 Pinzas para vasos periféricos
 Pincers-clamps vasculaires périphériques
 Pinze vascolari periferali

Herz-, Thorax- und Gefäßchirurgie

Cardio Thoracic and Vascular Surgery
 Cirugía cardíaca, torácica y vascular
 Chirurgie cardiaque, thoracique et vasculaire
 Chirurgia cardiaca, toracica e vascolare

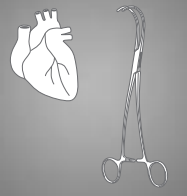

Atrauma



1/1

1/2

Dale
 24-340-18-07
 18 cm / 7 1/8"



1/1

24-341-17-07
 17,5 cm / 6 7/8"

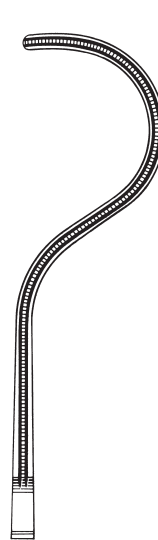

24-341-18-07
 18 cm / 7 1/8"

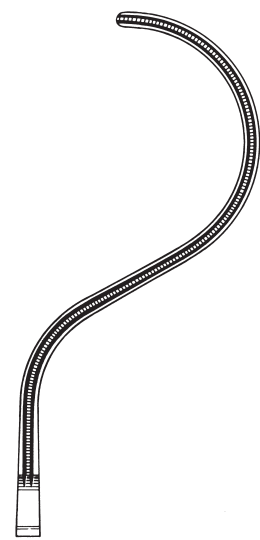

24-341-19-07
 18,5 cm / 7 2/8"

1/2

Dale
 24-341-17-07 -
 24-341-19-07

Profundaklemmen

Profunda Clamps

Pinzas para la profunda

Pinces fémorale

Pinze profunda

Atrauma



1/2

Gregory
24-342-14-07 -
24-342-18-07

1/1

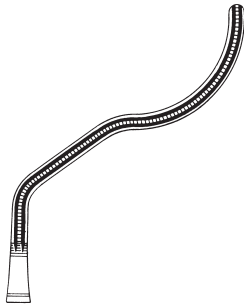

24-342-14-07
13,5 cm / 5 3/8"

1/1

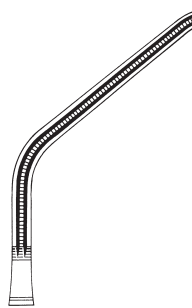

24-342-16-07
16 cm / 6 2/8"

1/1

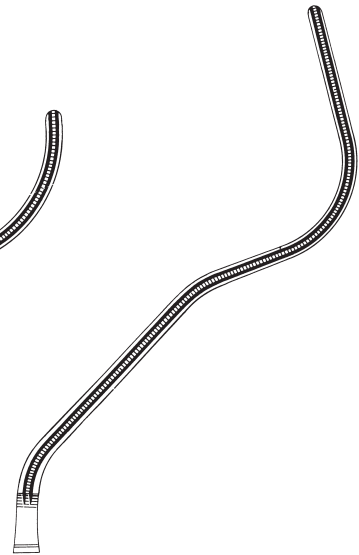

24-342-18-07
18 cm / 7 1/8"

Carotis-Shuntklemmen

Carotid Shunt Clamps
Pinzas para shunt carótido
Pincés pour carotide
Pinze carotis

Herz-, Thorax- und Gefäßchirurgie

Cardio Thoracic and Vascular Surgery
Cirugía cardíaca, torácica y vascular
Chirurgie cardiaque, thoracique et vasculaire
Chirurgia cardiaca, toracica e vascolare

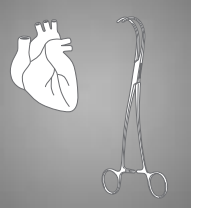

Javid
24-343-18-07
17,5 cm / 6 $\frac{7}{8}$ "



Javid
24-343-19-07
18,5 cm / 7 $\frac{3}{8}$ "

Peripheral-Gefäßklemmen

Peripheral Vascular Clamps

Pinzas para vasos periféricos

Pinces-clamps vasculaires périphériques

Pinze vascolari periferali

Atrauma



1/2

Martin
24-344-16-07 -
24-344-18-07

1/1

24-344-16-07
16 cm / 6 2/8"

24-344-18-07
18 cm / 7 1/8"



1/2

Martin
24-344-17-07 -
24-344-20-07

1/1

24-344-17-07
17 cm / 6 6/8"

24-344-20-07
19,5 cm / 7 5/8"

Aortaklemmen

Aortic Clamps
Pinzas aórticas
Pincers-clamps pour aorte
Pinze per aorta

Herz-, Thorax- und Gefäßchirurgie

Cardio Thoracic and Vascular Surgery
Cirugía cardíaca, torácica y vascular
Chirurgie cardiaque, thoracique et vasculaire
Chirurgia cardiaca, toracica e vascolare

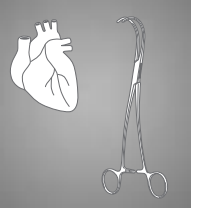

Atrauma



Wylie
24-344-24-07
24 cm / 9 4/8"



Wylie
24-344-27-07
27 cm / 10 5/8"

Aortaklemmen

Aortic Clamps

Pinzas aórticas

Pinces-clamps pour aorte

Pinze per aorta

Atrauma

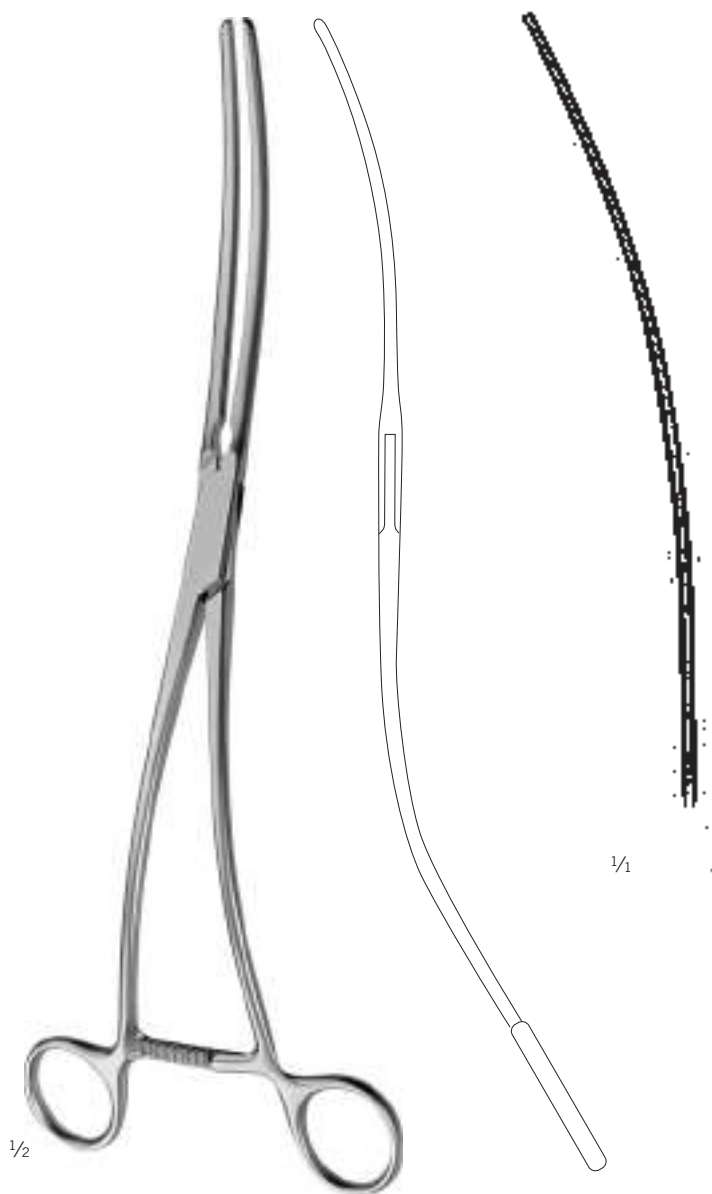

De Bakey
24-344-30-07
30 cm / 11 ⁶/₈"

Peripheral-Gefäßklemmen

Peripheral Vascular Clamps

Pinzas para vasos periféricos

Pinces-clamps vasculaires périphériques

Pinze vascolari periferali

Herz-, Thorax- und Gefäßchirurgie

Cardio Thoracic and Vascular Surgery

Cirurgía cardíaca, torácica y vascular

Chirurgie cardiaque, thoracique et vasculaire

Chirurgia cardiaca, toracica e vascolare

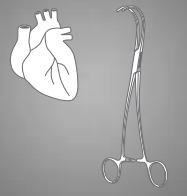

Atrauma

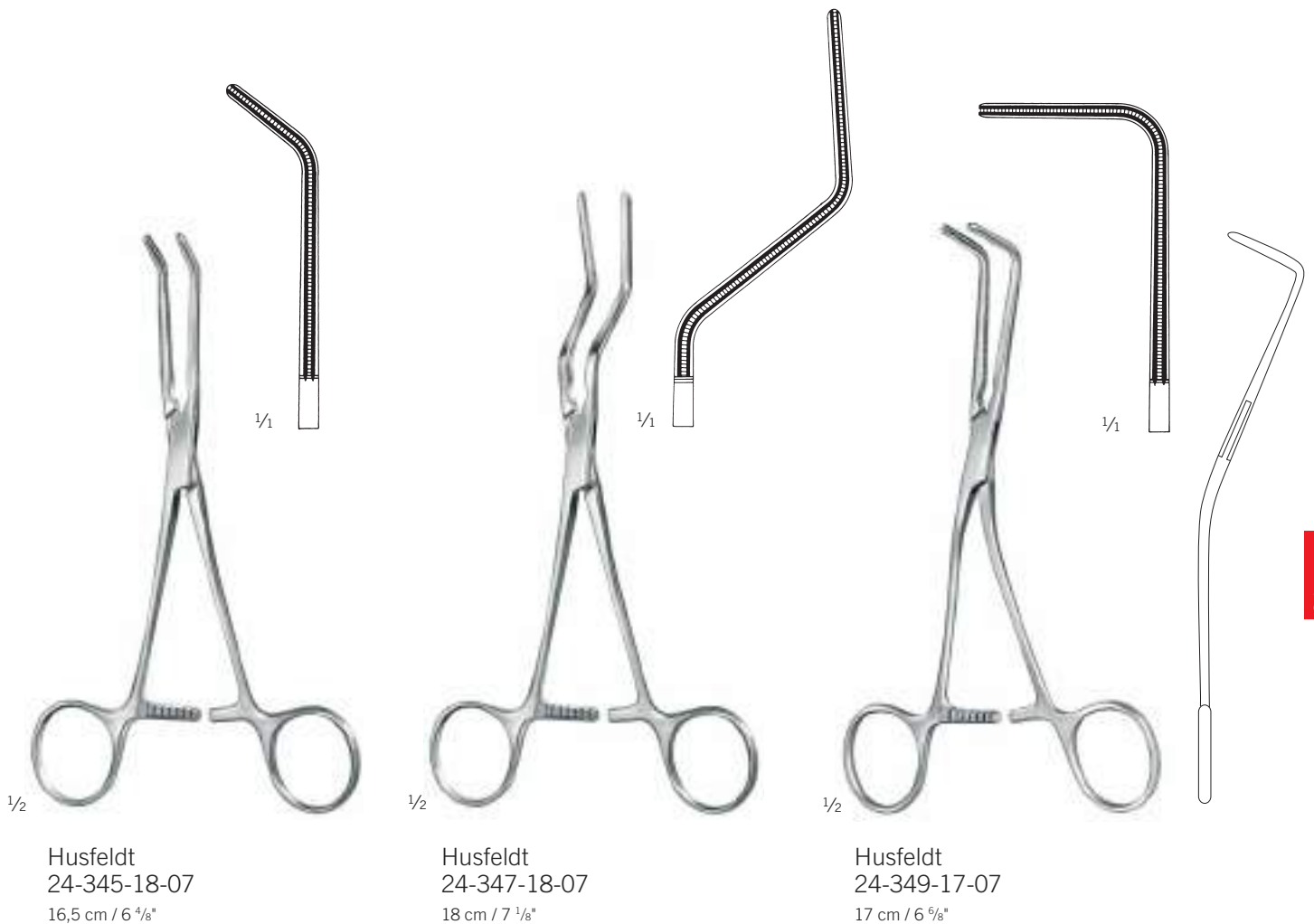

24

Gefäß-Messzirkel, Peripheral-Gefäßklemmen

Vascular Measuring Device, Peripheral Vascular Clamps

Compas para medir vasos, Pinzas para vasos periféricos

Compas pour mesurer la longueur des vaisseaux, Pincés-clamps vasculaires périphériques

Pinza vascolare compasso, Pinze vascolari periferali

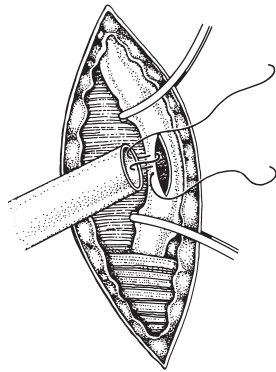
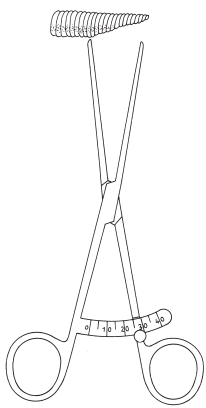

Atrauma



1/4



1/4

1/2

1/2

Martin
24-349-18-07

18 cm / 7 1/8"

Gefäß-Messzirkel

Vascular Measuring Device

Compas para medir vasos

Compas pour mesurer la longueur des vaisseaux

Pinza vascolare compasso

Henly
24-349-20-07

20 cm / 7 7/8"

Katheterklemmen

Catheter Clamps
 Pinzas para catéteres
 Pincès pour sondes
 Pinze per cateteri

Herz-, Thorax- und Gefäßchirurgie

Cardio Thoracic and Vascular Surgery
 Cirugía cardíaca, torácica y vascular
 Chirurgie cardiaque, thoracique et vasculaire
 Chirurgia cardiaca, toracica e vascolare

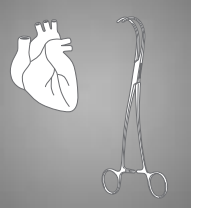

Atrauma

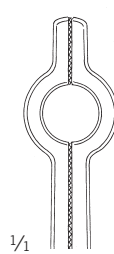

1/1

24-350-00-07

17 cm / 6 5/8"
 20 Charr.

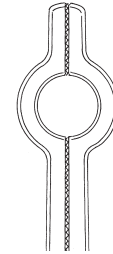

24-350-01-07

17 cm / 6 5/8"
 24 Charr.

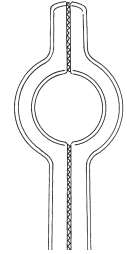

24-350-02-07

17 cm / 6 5/8"
 26 Charr.

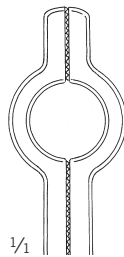

1/1

24-350-03-07

20 cm / 7 7/8"
 28 Charr.

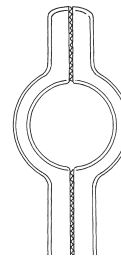

24-350-04-07

20 cm / 7 7/8"
 30 Charr.

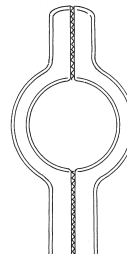

24-350-05-07

20 cm / 7 7/8"
 32 Charr.

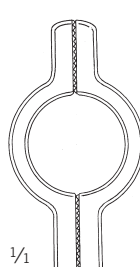

1/1

24-350-07-07

20 cm / 7 7/8"
 36 Charr.

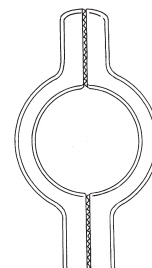

24-350-08-07

20 cm / 7 7/8"
 38 Charr.

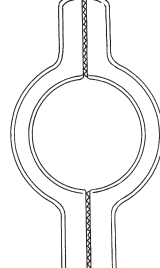

24-350-09-07

20 cm / 7 7/8"
 40 Charr.

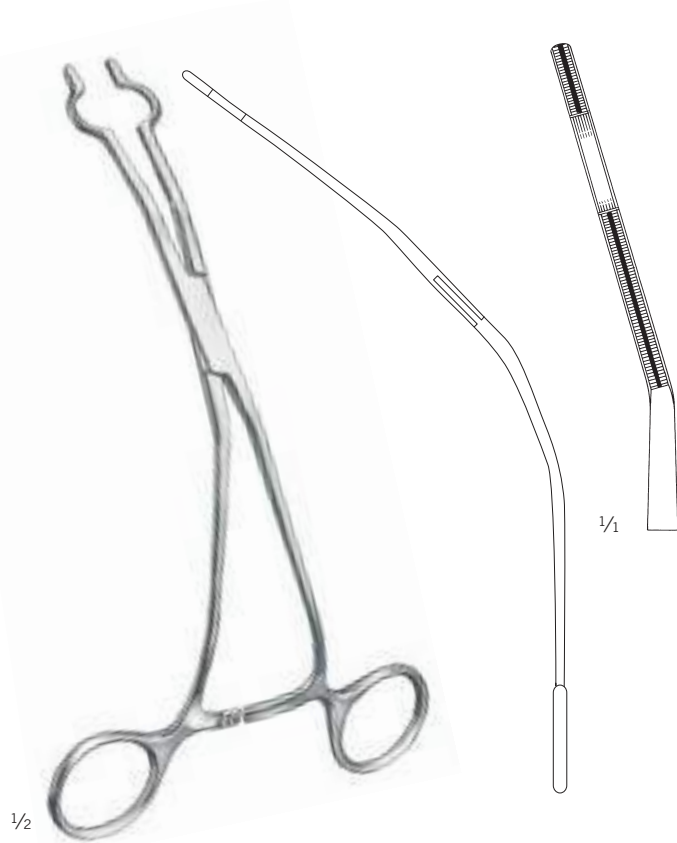

1/2

1/1

Cooley
 24-350-00-07 -
 24-350-09-07

24

Abdominale Aortaklemmen

Abdominal Aortic Clamps

Pinzas aórticas abdominales

Pinces-clamps pour aorte abdominaux

Pinze per aorta addominali

Atrauma

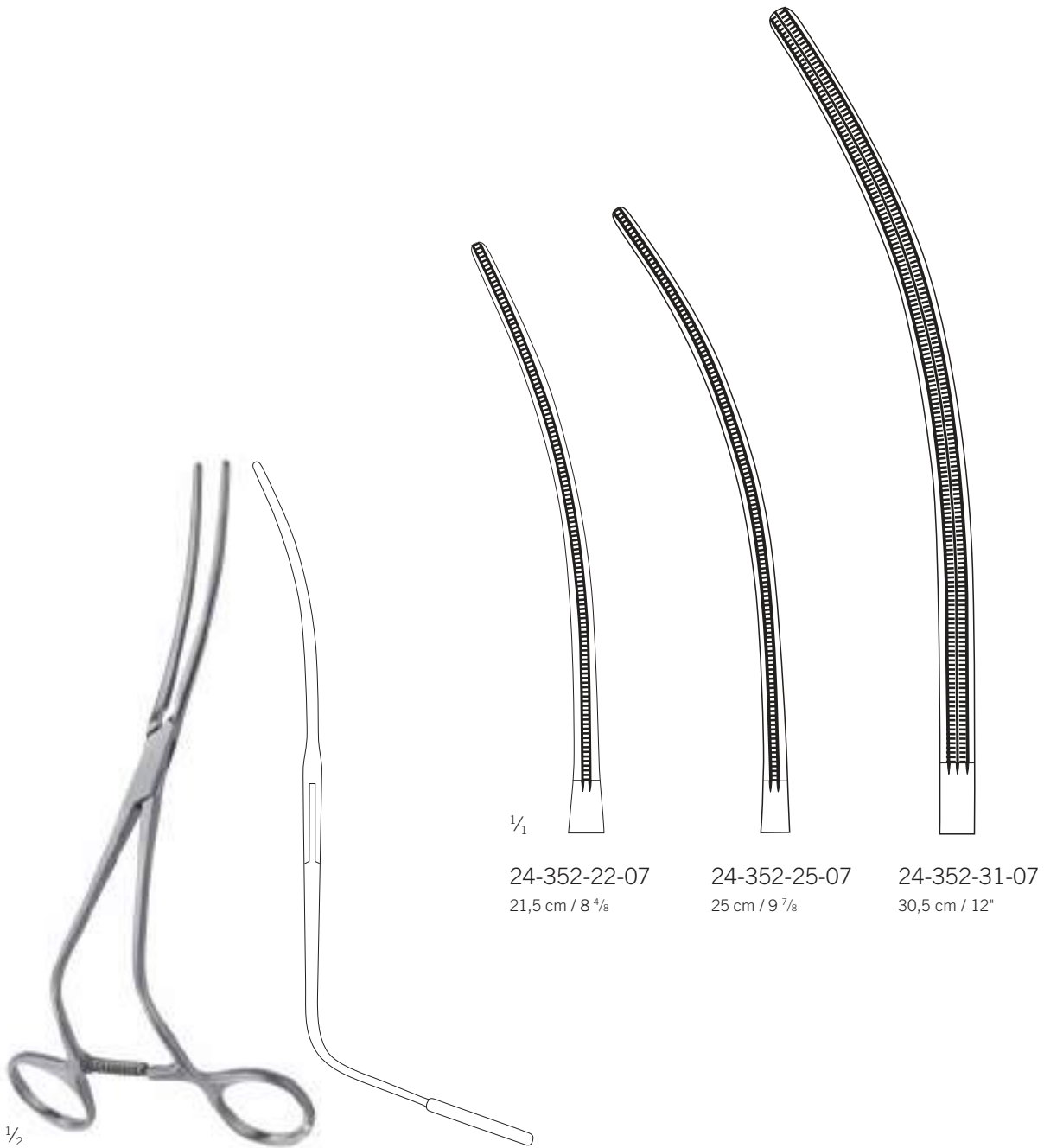

Zanger
24-352-22-07 -
24-352-31-07

Abdominale Aortaklemmen

Abdominal Aortic Clamps

Pinzas aórticas abdominales

Pinces-clamps pour aorte abdominaux

Pinze per aorta addominali

Herz-, Thorax- und Gefäßchirurgie

Cardio Thoracic and Vascular Surgery

Cirugía cardíaca, torácica y vascular

Chirurgie cardiaque, thoracique et vasculaire

Chirurgia cardiaca, toracica e vascolare

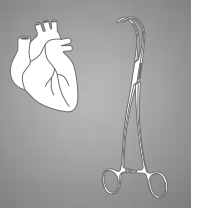

Atrauma

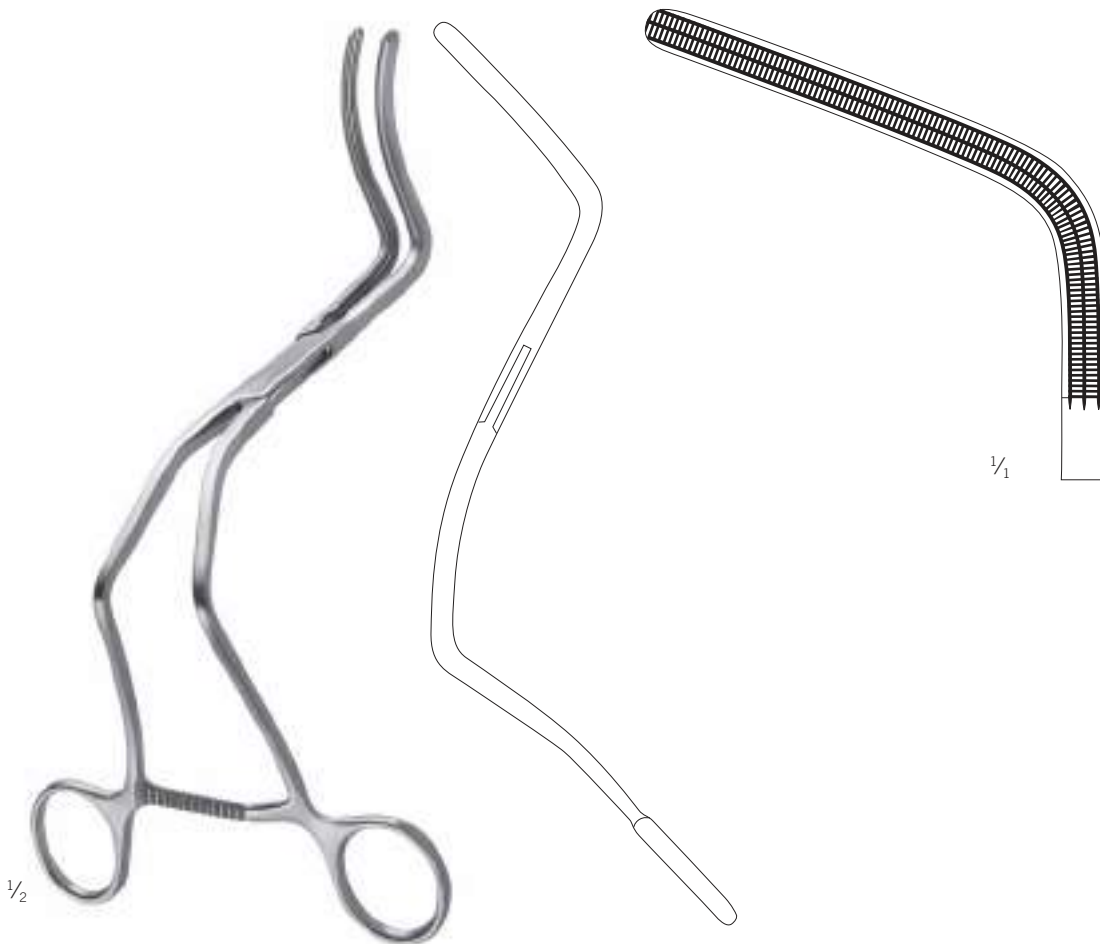

Grant
24-353-25-07
24,5 cm / 9 5/8

Abdominale Aortaklemmen

Abdominal Aortic Clamps

Pinzas aórticas abdominales

Pinces-clamps pour aorte abdominaux

Pinze per aorta addominali

Atrauma

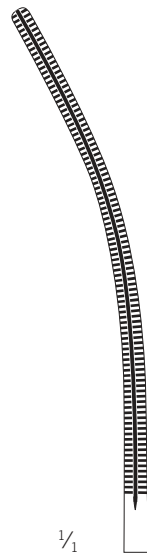

24-354-19-07
19 cm / 7 ⁴/₈"

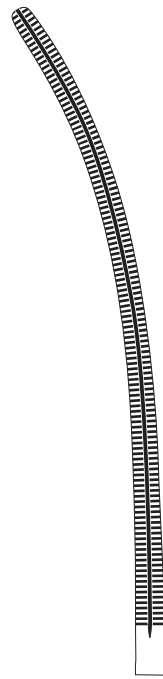

24-354-27-07
26,5 cm / 10 ⁴/₈"

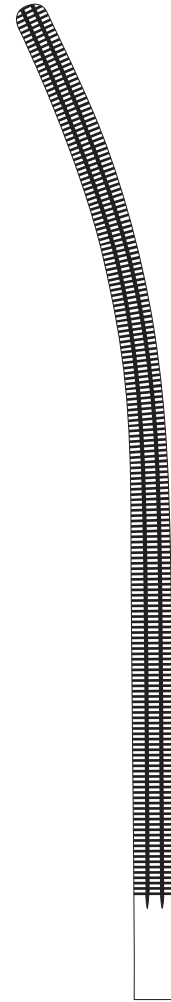

24-354-34-07
33,5 cm / 13 ⁴/₈"

Cooley
24-354-19-07 -
24-354-34-07

Abdominale Aortaklemmen

Abdominal Aortic Clamps
Pinzas aórticas abdominales
Pincers-clamps pour aorte abdominaux
Pinze per aorta addominali

Herz-, Thorax- und Gefäßchirurgie

Cardio Thoracic and Vascular Surgery
Cirugía cardíaca, torácica y vascular
Chirurgie cardiaque, thoracique et vasculaire
Chirurgia cardiaca, toracica e vascolare

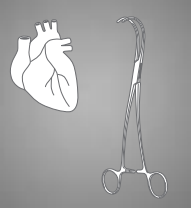

Atrauma

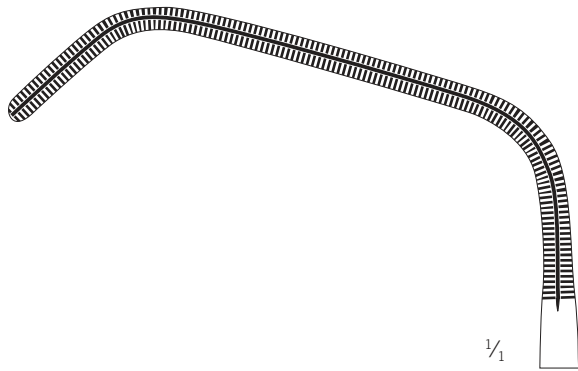

1/2



1/2

Cooley
24-354-26-07
26 cm / 10 2/8"

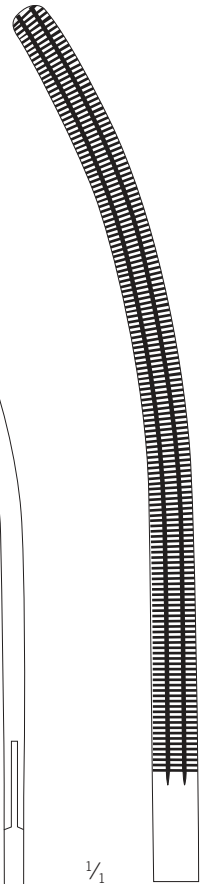

1/2

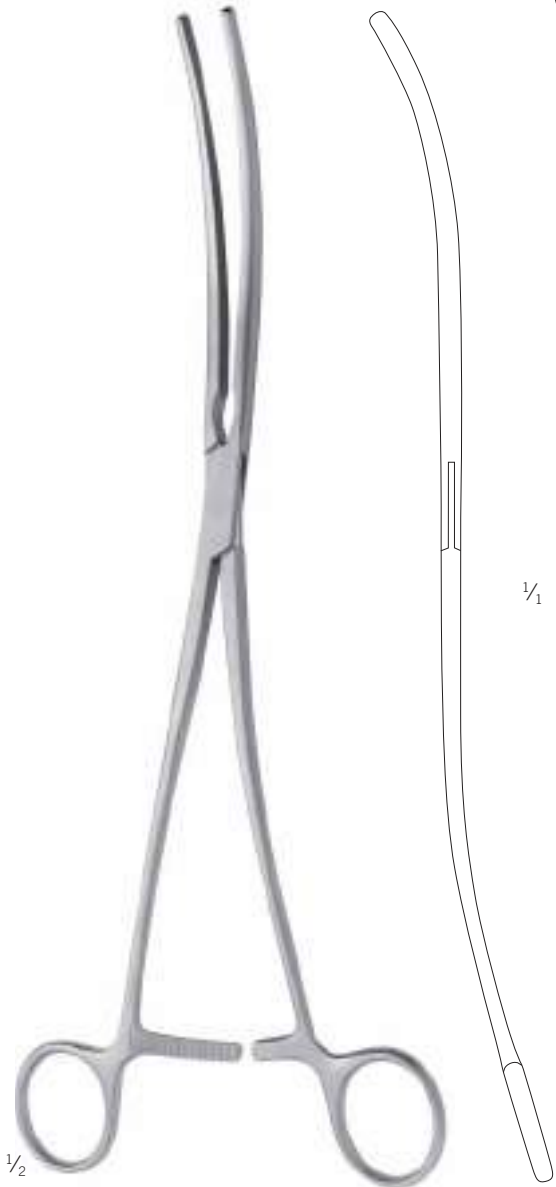

1/2

Cooley
24-354-32-07
31,5 cm / 12 2/8"

Gefäßpinzetten

Vascular Forceps

Pinzas de disección vascular

Pinces à dissection vasculaires

Pinze per dissezione vascolari

Atrauma



1/1

1,5 mm	1,5 mm	1,5 mm
24-386-16-07	24-386-20-07	24-386-24-07
16 cm / 6 2/8"	20 cm / 7 7/8"	25 cm / 9 7/8"



1/1

2,0 mm	2,0 mm	2,0 mm	2,0 mm
24-388-16-07	24-388-20-07	24-388-24-07	24-388-30-07
16 cm / 6 2/8"	20 cm / 7 7/8"	25 cm / 9 7/8"	30 cm / 11 6/8"



1/1

2,7 mm	2,7 mm	2,7 mm	2,7 mm
24-384-16-07	24-384-20-07	24-384-24-07	24-384-30-07
16 cm / 6 2/8"	20 cm / 7 7/8"	25 cm / 9 7/8"	30 cm / 11 6/8"



1/2

De Bakey
24-384-16-07 -
24-390-30-07



1/1

3,5 mm	3,5 mm	3,5 mm	3,5 mm
24-390-16-07	24-390-20-07	24-390-24-07	24-390-30-07
16 cm / 6 2/8"	20 cm / 7 7/8"	25 cm / 9 7/8"	30 cm / 11 6/8"

Gefäßpinzetten, Bulldogklemmen

Vascular Forceps, Bulldog Clamps

Pinzas de disección vascular, Clamps Bulldog

Pinces à dissection vasculaires, Clamps Bulldog

Pinze per dissezione vascolari, Pinze Bulldog

Herz-, Thorax- und Gefäßchirurgie

Cardio Thoracic and Vascular Surgery

Cirugía cardíaca, torácica y vascular

Chirurgie cardiaque, thoracique et vasculaire

Chirurgia cardiaca, toracica e vascolare

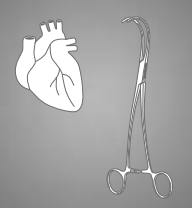

Atrauma



1/2

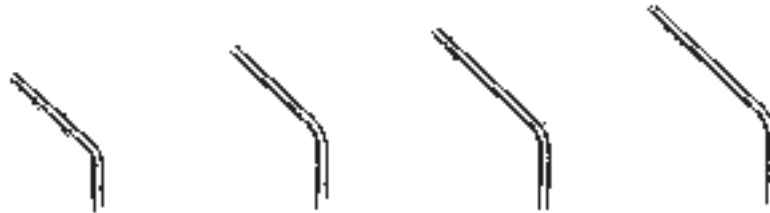

1/1

2,0 mm	2,0 mm	2,0 mm	2,0 mm
24-389-16-07	24-389-20-07	24-389-24-07	24-389-30-07
16 cm / 6 2/8"	20 cm / 7 7/8"	25 cm / 9 7/8"	30 cm / 11 5/8"

De Bakey
24-389-16-07 -
24-389-30-07

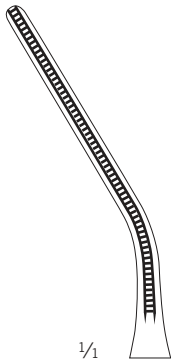

1/1



1/2

24-394-01-07
9,5 cm / 3 5/8"
Gregory-Style
rechts
right
derecho
droit
destra



1/2

24-394-02-07
9,5 cm / 3 5/8"
Gregory-Style
links
left
izquierdo
gauche
sinistra

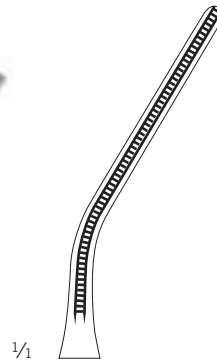

1/1

Bulldogklemmen

Bulldog Clamps
Clamps Bulldog
Clamps Bulldog
Pinze Bulldog

Atrauma 



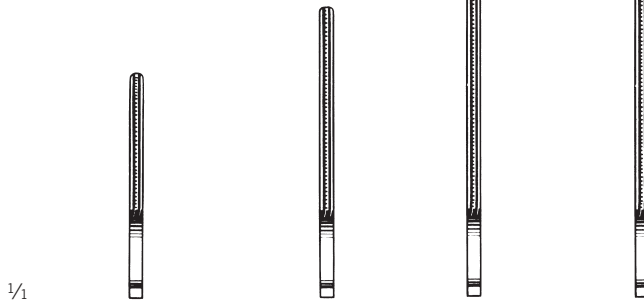

1/2

Glover
24-398-06-07 -
24-398-11-07



1/1

	24-398-06-07	24-398-07-07	24-398-09-07	24-398-11-07
	7 cm / 2 5/8"	8 cm / 3 1/8"	9,5 cm / 3 5/8"	11 cm / 4 2/8"
	30 mm	40 mm	50 mm	70 mm



1/2

24-395-23-07
24 cm / 9 4/8"

Anlegezange für Bulldogklemmen
Applying Forceps for Bulldog clamps
Pinza aplicadora para clamps bulldog
Pince pour poser les clamps Bulldog
Pinza per posizionare le pinze Bulldog



1/2

Glover
24-399-06-07 -
24-399-11-07

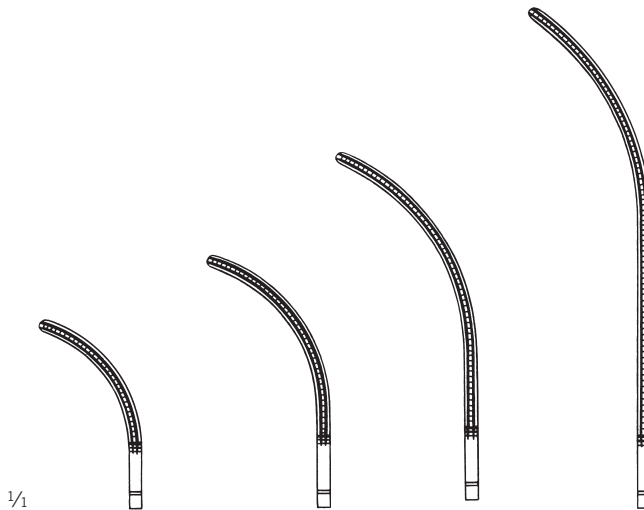

1/1

	24-399-06-07	24-399-07-07	24-399-09-07	24-399-11-07
	6,5 cm / 2 4/8"	7,5 cm / 3"	9,0 cm / 3 4/8"	10,5 cm / 4"
	25 mm	35 mm	45 mm	65 mm

Coarctationsklemmen

Coarctation Clamps
Pinzas para coarctación
Pincers-clamps pour coarctation
Pinze per coartazione

Herz-, Thorax- und Gefäßchirurgie

Cardio Thoracic and Vascular Surgery
Cirugía cardíaca, torácica y vascular
Chirurgie cardiaque, thoracique et vasculaire
Chirurgia cardiaca, toracica e vascolare

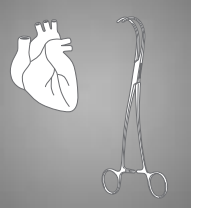

Atrauma

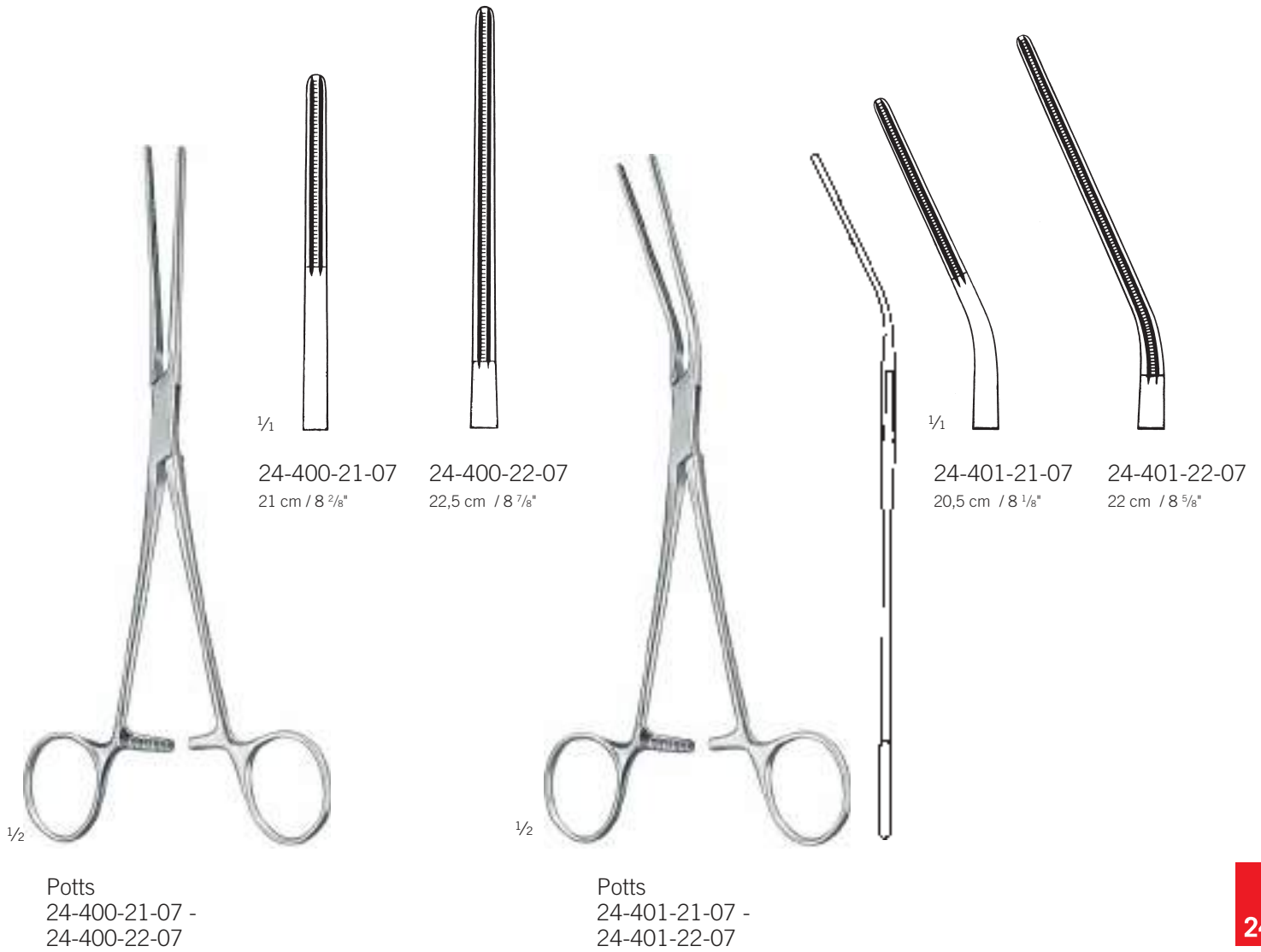

Coarctationsklemmen

Coarctation Clamps
Pinzas para coarctación
Pincers-clamps pour coarctation
Pinze per coartazione

Atrauma



1/2

Potts
24-403-21-07 -
24-403-22-07



1/1

24-403-21-07
20,5 cm / 8"

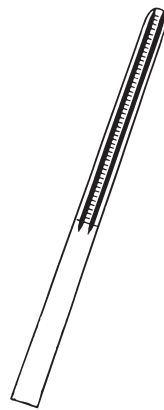

24-403-22-07
22 cm / 8 5/8"

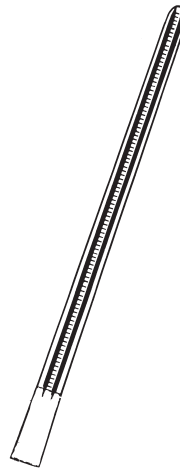

Anastomosenklemmen, Ligaturklemmen

Anastomosis Clamps, Ligature Forceps
Pinzas para anastomosis, Pinzas para ligaduras
Pinces-clamps à anastomose, Pinces à ligatures
Pinze per anastomosi, Pinze per legature

Herz- und Gefäßchirurgie

Cardio Thoracic and Vascular Surgery
Cirugía cardíaca, torácica y vascular
Chirurgie cardiaque, thoracique et vasculaire
Chirurgia cardiaca, toracica e vascolare

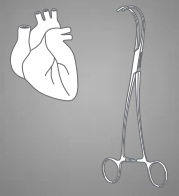

Atrauma



1/1

24-405-22-07
21,5 cm / 8 4/8"



24-407-22-07
22 cm / 8 5/8"



1/1

24-408-19-07
19 cm / 7 4/8"

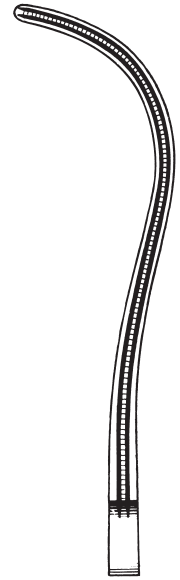

24-408-23-07
24 cm / 9 4/8"

Potts
24-405-22-07 -
24-407-22-07

De Bakey
24-408-19-07 -
24-408-23-07

Peripheral-Gefäßklemmen

Peripheral Vascular Clamps

Pinzas para vasos periféricos

Pinces-clamps vasculaires périphériques

Pinze vascolari periferali

Atrauma



De Bakey
24-409-16-07
16 cm / 6 2/8"



De Bakey
24-411-19-07
19 cm / 7 4/8"



De Bakey
24-411-20-07
20 cm / 7 7/8"

Peripheral-Gefäßklemmen

Peripheral Vascular Clamps

Pinzas para vasos periféricos

Pinces-clamps vasculaires périphériques

Pinze vascolari periferali

Herz-, Thorax- und Gefäßchirurgie

Cardio Thoracic and Vascular Surgery

Cirugía cardíaca, torácica y vascular

Chirurgie cardiaque, thoracique et vasculaire

Chirurgia cardiaca, toracica e vascolare

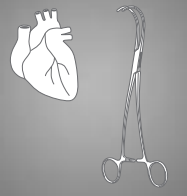

Atrauma



1/2

Leland-Jones
24-413-18-07 -
24-413-20-07

1/1

24-413-18-07
18 cm / 7 1/8"

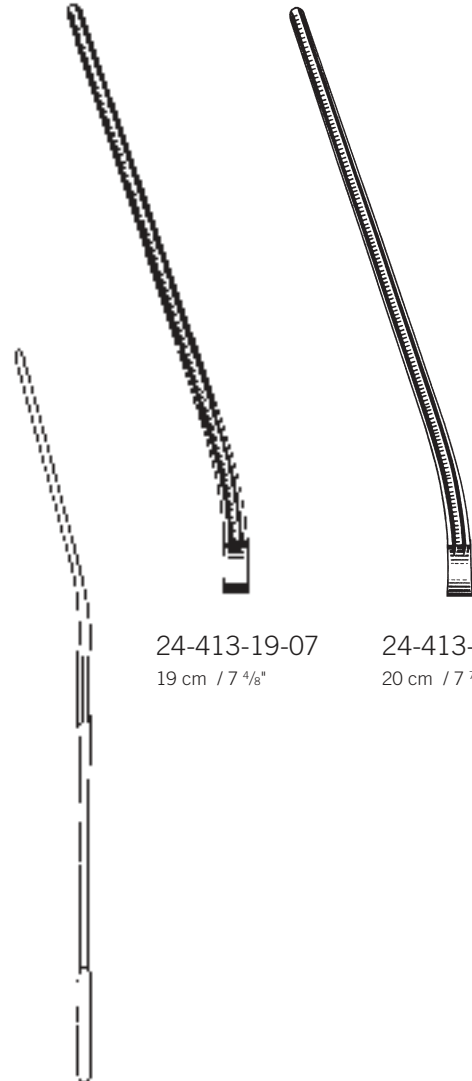

24-413-19-07
19 cm / 7 4/8"

24-413-20-07
20 cm / 7 7/8"

Mehrzweck-Gefäßklemmen

Multi purpose Vascular Clamps
 Pinzas vasculares de usos múltiples
 Pinces vasculaires universelles
 Pinze vascolari universali

Atrauma



1/2

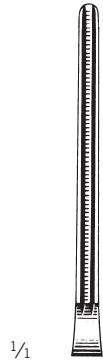

1/1

24-414-15-07
 15 cm / 5 7/8"



24-414-18-07
 18,5 cm / 7 2/8"

Bainbridge
 24-414-15-07 -
 24-414-18-07



1/2

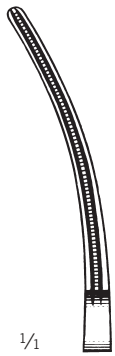

1/1

24-415-15-07
 15 cm / 5 7/8"



24-415-18-07
 18,5 cm / 7 2/8"

Bainbridge
 24-415-15-07 -
 24-415-18-07

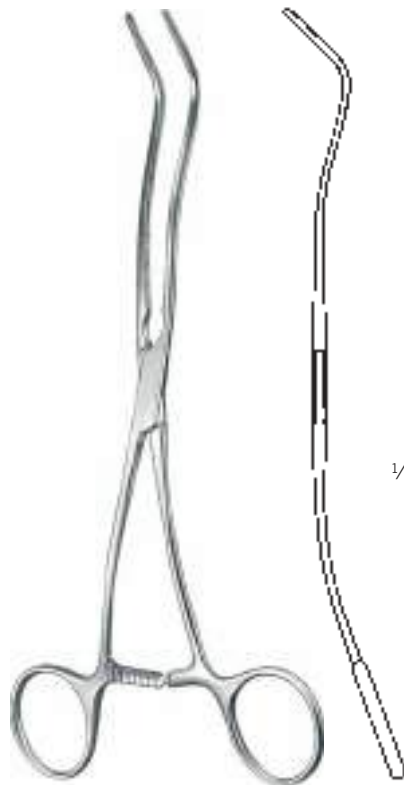

1/2

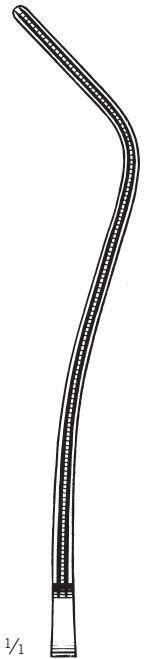

1/1

De Bakey
 24-416-20-07
 20 cm / 7 7/8"

Aorta-Aneurysmaklemmen

Aortic Aneurysm Clamps

Pinzas para aneurisma de aórtica

Pinces-clamps pour anévrisme de l'aorte

Pinze per aneurisma della aorta

Herz-, Thorax- und Gefäßchirurgie

Cardio Thoracic and Vascular Surgery

Cirugía cardíaca, torácica y vascular

Chirurgie cardiaque, thoracique et vasculaire

Chirurgia cardiaca, toracica e vascolare

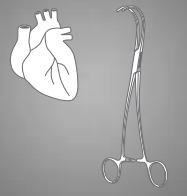

Atrauma



1/2



1/4

24-417-26-07
26 cm / 10 2/8"

24-417-27-07
27 cm / 10 5/8"

24-417-31-07
31 cm / 12 2/8"

24-417-33-07
33 cm / 13"

24

De Bakey
24-417-26-07 -
24-417-33-07

Aorta-Aneurysmaklemmen

Aortic Aneurysm Clamps

Pinzas para aneurisma de aórtica

Pinces-clamps pour anévrisme de l'aorte

Pinze per aneurisma della aorta

Atrauma



1/2

1/1

De Bakey
24-418-28-07
28 cm / 11"



1/2

1/1

De Bakey
24-419-30-07
30 cm / 11 6/8"

Ligaturklemmen

Ligature Forceps
Pinzas para ligaduras
Pincès à ligatures
Pinze per legature

Herz-, Thorax- und Gefäßchirurgie

Cardio Thoracic and Vascular Surgery
Cirugía cardíaca, torácica y vascular
Chirurgie cardiaque, thoracique et vasculaire
Chirurgia cardiaca, toracica e vascolare

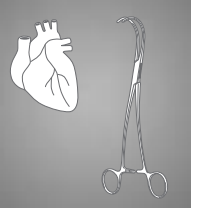

Atrauma



1/2

1/4

Cooley
24-420-25-07
25 cm / 9 7/8"



1/2

1/4

De Bakey
24-420-27-07
27 cm / 10 5/8"

Ligaturklemmen, Aortaklemmen

Ligature Forceps, Aortic Clamps

Pinzas para ligaduras, Pinzas aórticas

Pinces à ligatures, Pinces-clamps pour aorte

Pinze per legature, Pinze per aorta

Atrauma

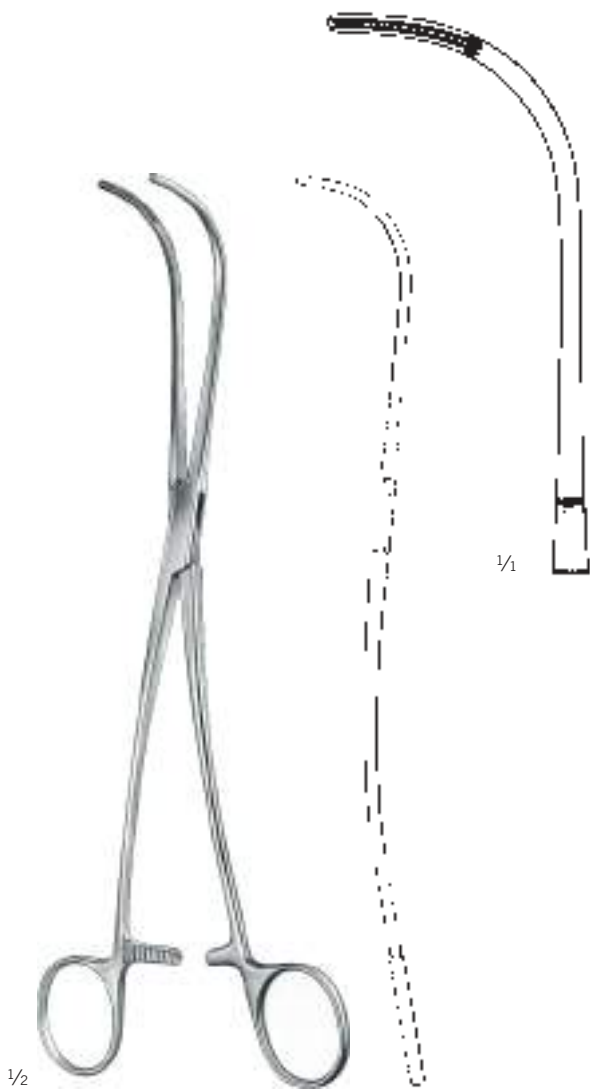

1/2

De Bakey
24-421-24-07
24,5 cm / 9 5/8"

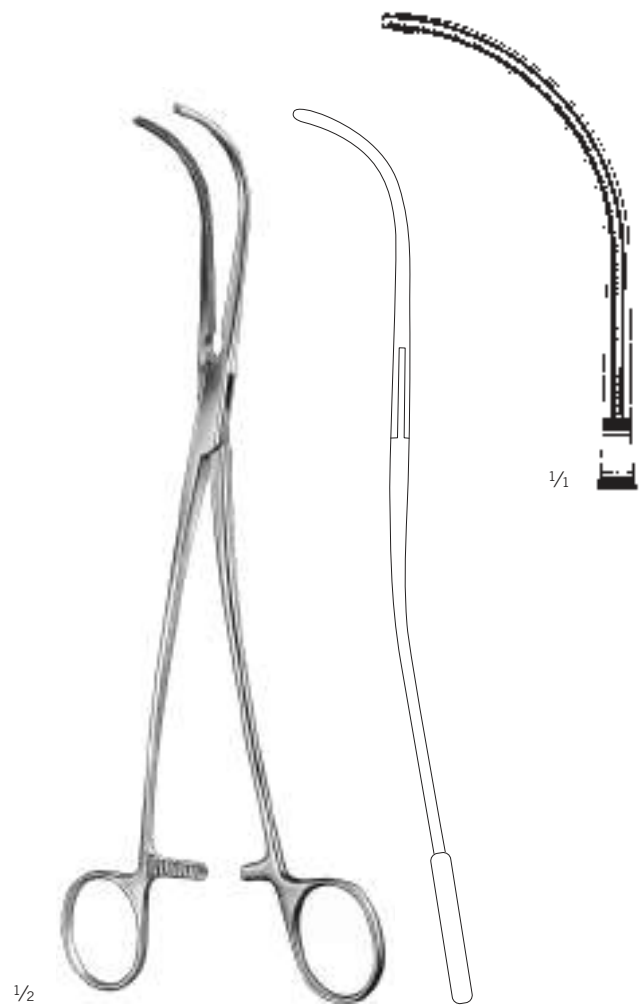

1/2

De Bakey
24-422-24-07
24,5 cm / 9 5/8"

Aortaklemmen

Aortic Clamps
Pinzas aórticas
Pinces-clamps pour aorte
Pinze per aorta

Herz-, Thorax- und Gefäßchirurgie

Cardio Thoracic and Vascular Surgery
Cirugía cardíaca, torácica y vascular
Chirurgie cardiaque, thoracique et vasculaire
Chirurgia cardiaca, toracica e vascolare

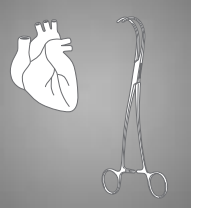

Atrauma



1/2

De Bakey
24-423-25-07 -
24-423-26-07
27 cm / 10 5/8"



1/4

24-423-25-07

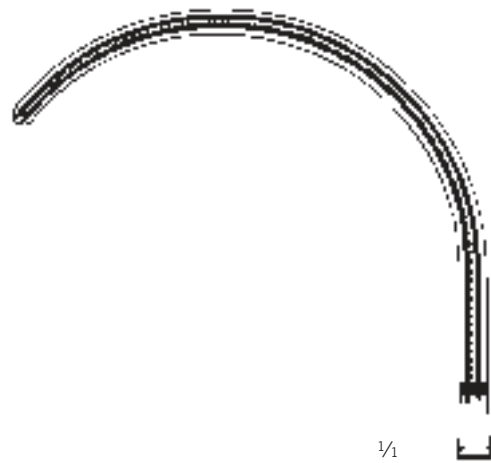

1/4

24-423-26-07

Aortaklemmen

Aortic Clamps

Pinzas aórticas

Pinces-clamps pour aorte

Pinze per aorta

Atrauma

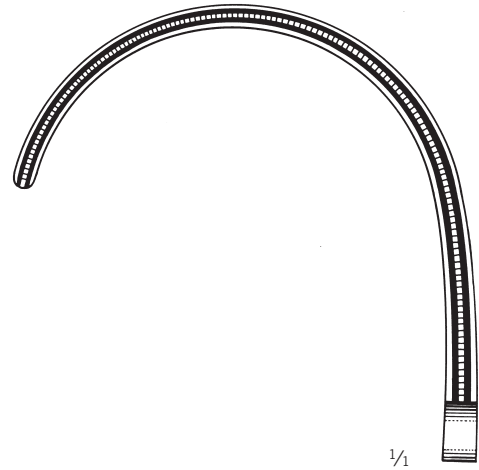
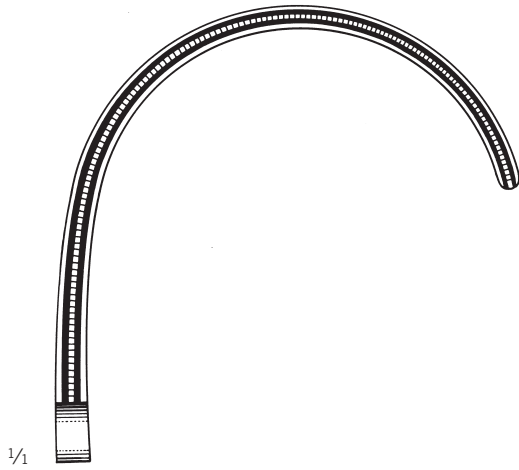

Weber
24-424-01-07
24 cm / 9 4/8"



Weber
24-424-02-07
24 cm / 9 4/8"

Aorta-, Anastomosen-, Vena-Cava-Klemmen

Aortic Clamps, Anastomosis Clamps, Vena Cava Clamps

Pinzas aórticas, Pinzas para anastomosis, Pinzas para vena cava

Pinces-clamps pour aorte, Pinces-clamps pour anastomos, Pinzas pour vena cava

Pinze per aorta, Pinze per anastomosi, Pinze per vena cava

Herz- und Gefäßchirurgie

Cardio Thoracic and Vascular Surgery

Cirugía cardíaca, torácica y vascular

Chirurgie cardiaque, thoracique et vasculaire

Chirurgia cardiaca, toracica e vascolare

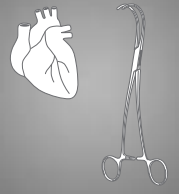

Atrauma



1/1

24-424-03-07

22,5 cm / 8 7/8"

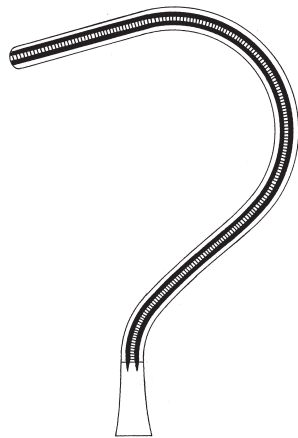

24-424-04-07

23 cm / 9"

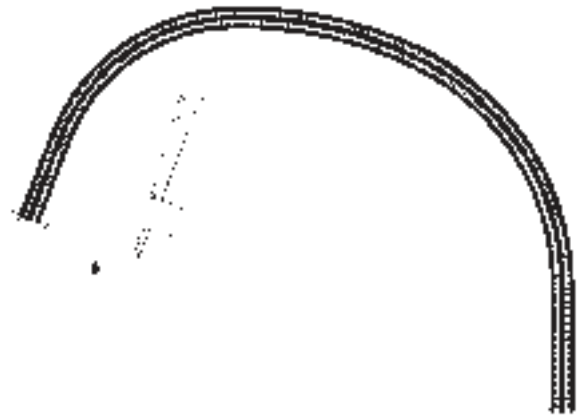

1/1



1/2

Wylie
24-424-03-07 -
24-424-04-07

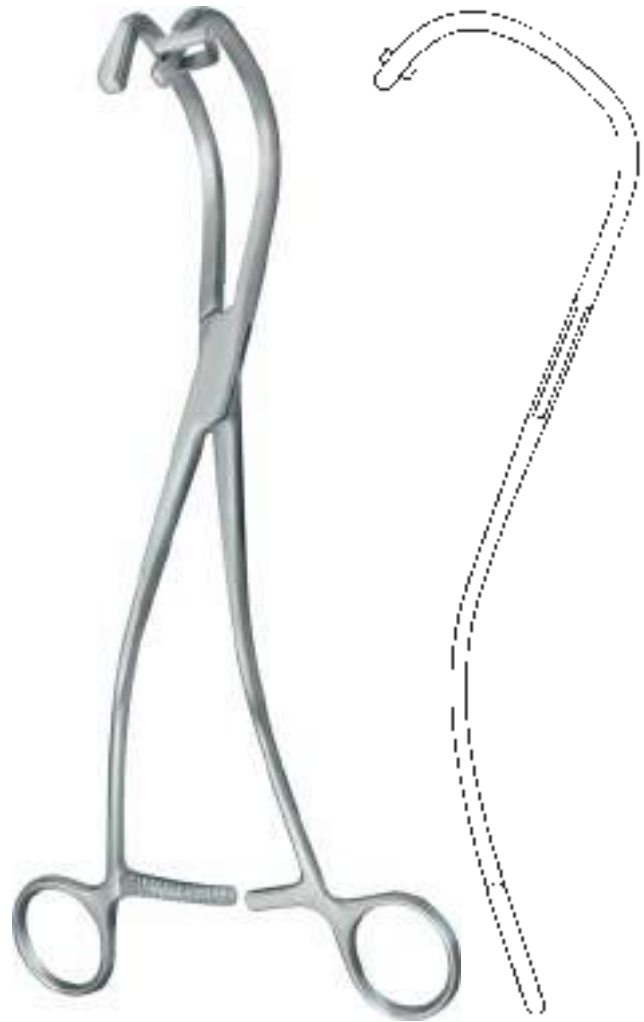

1/2

Calne
24-425-00-07
27 cm / 10 5/8"

Leberklemmen

Liver Forceps

Pinzas para hígado

Pinces pour le foie

Pinze per il fegato

Atrauma



1/1

24-425-01-07
25 cm / 9 7/8"

24-425-02-07
26 cm / 10 2/8"

24-425-03-07
27 cm / 10 5/8"

1/2

Pittsburgh
24-425-01-07 -
24-425-03-07

Nieren u.- Pankreas-Klemmen

Forceps for kidney and pancreas

Pinzas para riñón y páncreas

Pinces pour le rein et pancréas

Pinze per il rene e pancreas

Herz-, Thorax- und Gefäßchirurgie

Cardio Thoracic and Vascular Surgery

Cirugía cardíaca, torácica y vascular

Chirurgie cardiaque, thoracique et vasculaire

Chirurgia cardiaca, toracica e vascolare

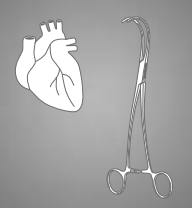

Atrauma

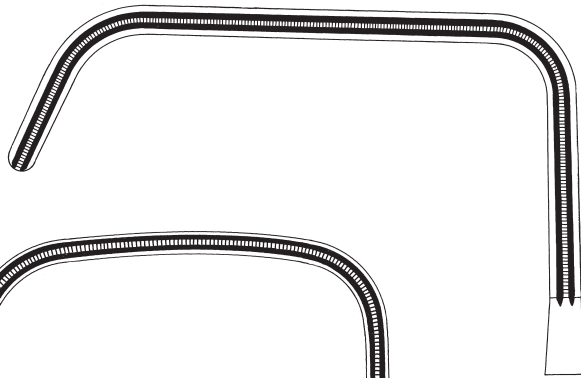

24-425-09-07

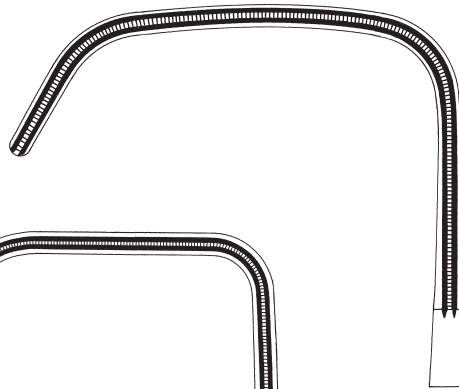

24-425-08-07

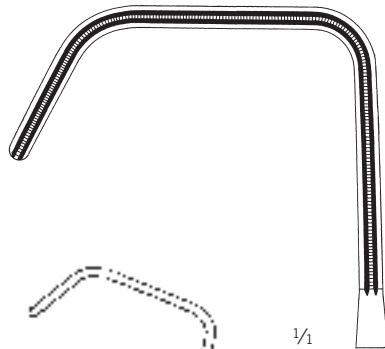

1/1

24-425-07-07

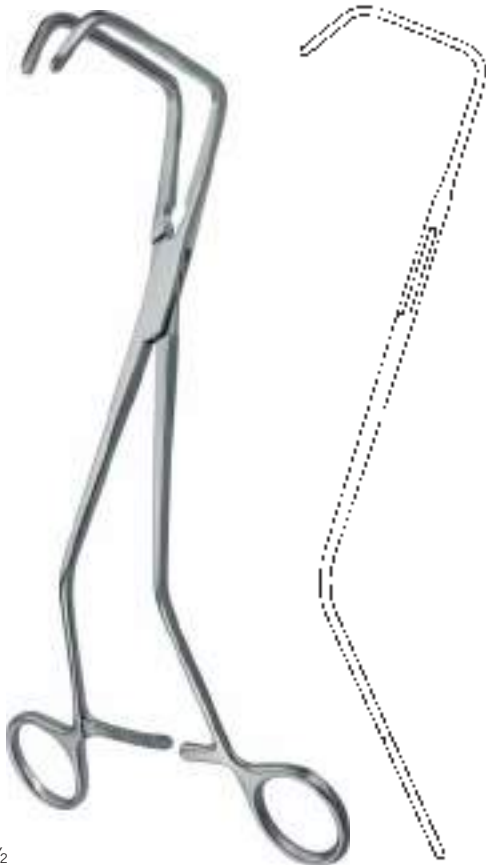

1/2



1/2

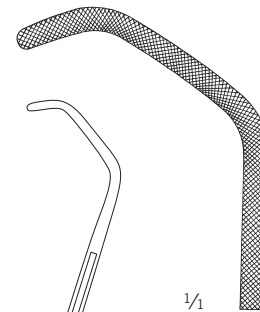

1/1

kreuzgeriffes Maul
cross serrated jaw
boca estriada en forma de cruz
mors à rainures croisées
morso con striatura cruciforme

24-425-07-07 -
24-425-09-07
20 cm / 7 7/8"

Satinsky
24-425-15-07
15,5 cm / 6"

24

Tangentialklemmen

Tangential Occlusion Clamps

Pinzas para oclusión tangencial

Pinces-clamps pour occlusion tangentielle

Pinze per occlusione tangenziale

Atrauma

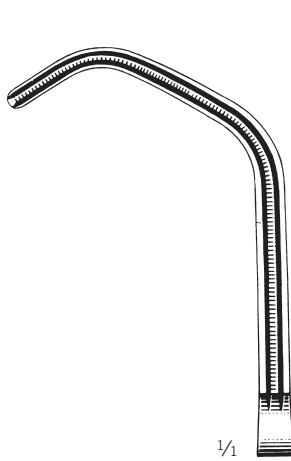

1/1

24-425-20-07
22 cm / 8 5/8"



24-425-24-07
26 cm / 10 2/8"

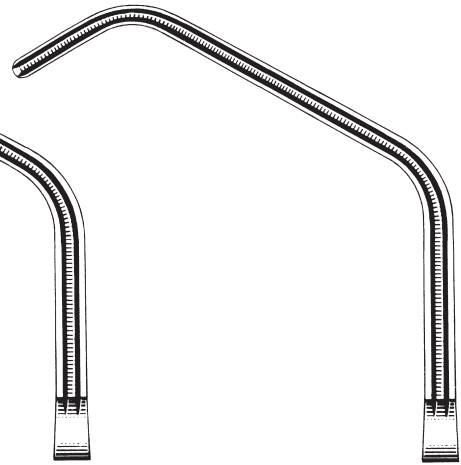

24-425-25-07
26,5 cm / 10 4/8"

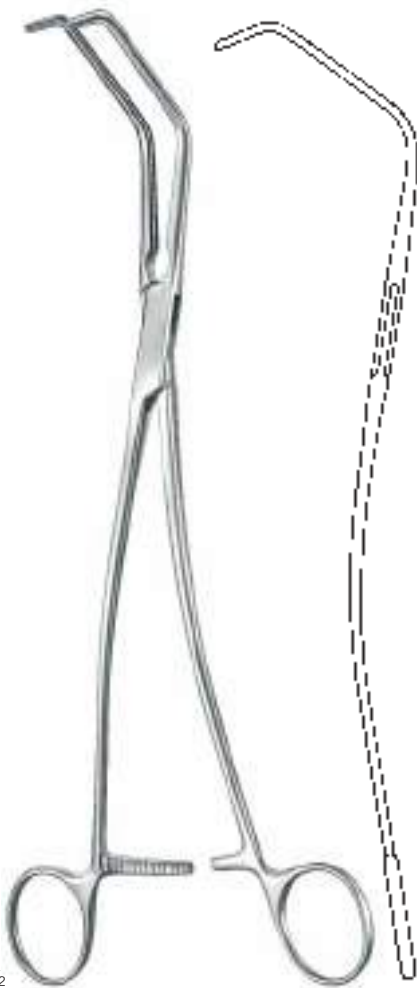

1/2

Satinsky
24-425-20-07 -
24-425-27-07



1/1

24-425-26-07
27,5 cm / 10 5/8"



24-425-27-07
28,5 cm / 11 2/8"

Aurikelklemmen

Auricle Clamps
Pinzas para aurícula
Pincès auriculaires
Pinze ventricolari

Herz-, Thorax- und Gefäßchirurgie

Cardio Thoracic and Vascular Surgery
Cirugía cardíaca, torácica y vascular
Chirurgie cardiaque, thoracique et vasculaire
Chirurgia cardiaca, toracica e vascolare

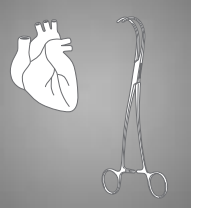

Atrauma

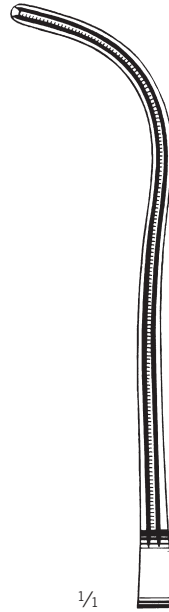

1/1

24-426-01-07
24,5 cm / 9 5/8"

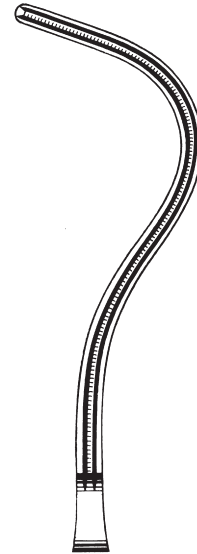

24-426-02-07
24 cm / 9 4/8"



1/2

Harken
24-426-01-07 -
24-426-04-07

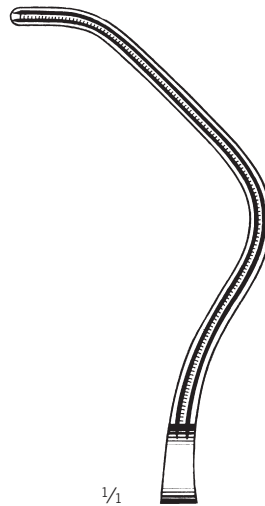

1/1

24-426-03-07
23 cm / 9"



24-426-04-07
23,5 cm / 9 2/8"

24

Bronchusklemmen

Bronchus Clamps

Pinzas bronquiales

Pinces-clamps à bronches

Pinze per bronchi

Atrauma

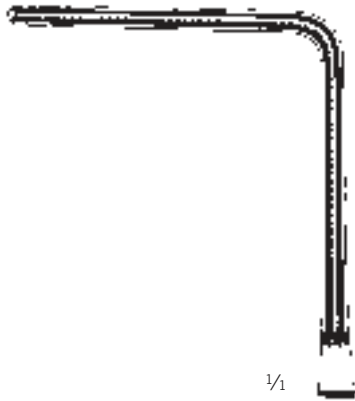

1/1

24-427-23-07
23 cm / 9"

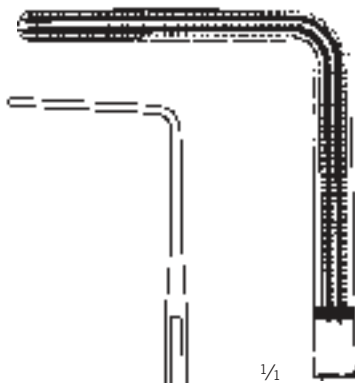

1/1

24-427-25-07
25,5 cm / 10"



1/2

Lees
24-427-23-07 -
24-427-25-07



1/2

Lees
24-429-25-07
26 cm / 10 2/8"

Anastomosenklemmen

Anastomosis Clamps
Pinzas para anastomosis
Pinces-clamps pour anastomose
Pinze per anastomosi

Herz-, Thorax- und Gefäßchirurgie

Cardio Thoracic and Vascular Surgery
Cirugía cardíaca, torácica y vascular
Chirurgie cardiaque, thoracique et vasculaire
Chirurgia cardiaca, toracica e vascolare

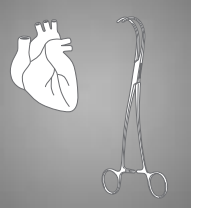

Atrauma

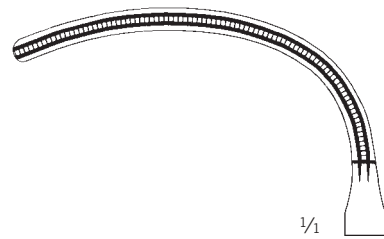

1/1

24-430-00-07
18 cm / 7 1/8"

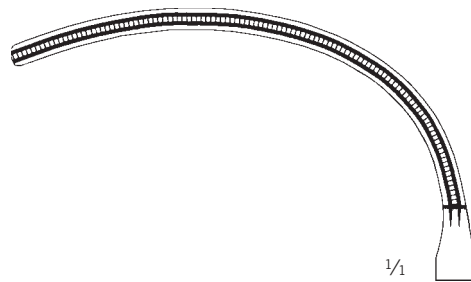

1/1

24-430-01-07
22 cm / 8 5/8"



1/2

Glover
24-430-00-07 -
24-430-01-07

Aortaklemmen, Anastomosenklemmen

Aortic Clamps, Anastomosis Clamps

Pinzas aórticas, Pinzas para anastomosis

Pinces-clamps pour aorte, Pinces-clamps pour anastomose

Pinze per aorta, Pinze per anastomosi

Atrauma



1/2

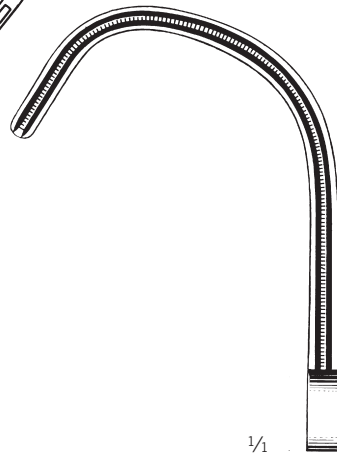
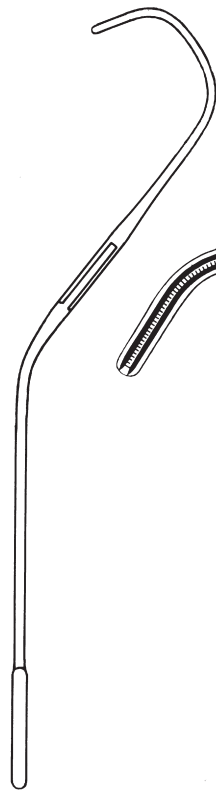

1/1

24-430-21-07
22,5 cm / 8 7/8"



24-430-22-07
20,5 cm / 8 1/8"

Lambert-Kay
24-430-21-07 -
24-430-22-07



1/2

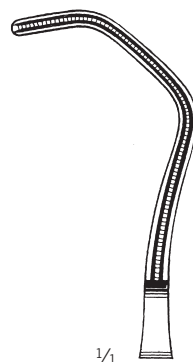

1/1

De Bakey
24-431-17-07
16,5 cm / 6 4/8"

Aortaklemmen

Aortic Clamps
Pinzas aórticas
Pinces-clamps pour aorte
Pinze per aorta

Herz-, Thorax- und Gefäßchirurgie

Cardio Thoracic and Vascular Surgery
Cirugía cardíaca, torácica y vascular
Chirurgie cardiaque, thoracique et vasculaire
Chirurgia cardiaca, toracica e vascolare

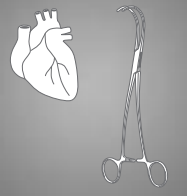

Atrauma

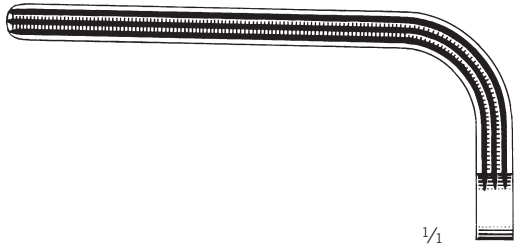

24-432-18-07
18,5 cm / 7 3/8"

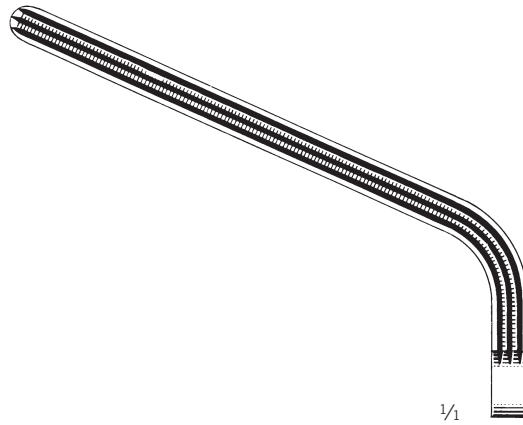

24-432-20-07
20 cm / 8"

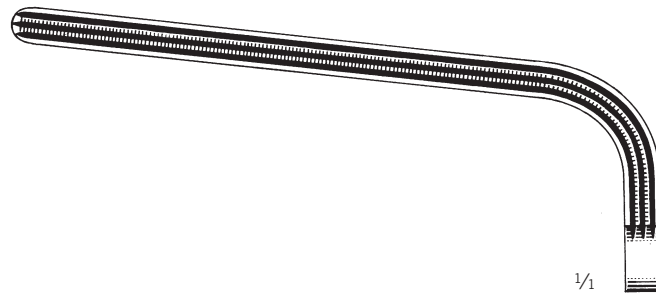

24-432-23-07
26 cm / 10 2/8"



Morris-De Bakey
24-432-18-07 -
24-432-25-07

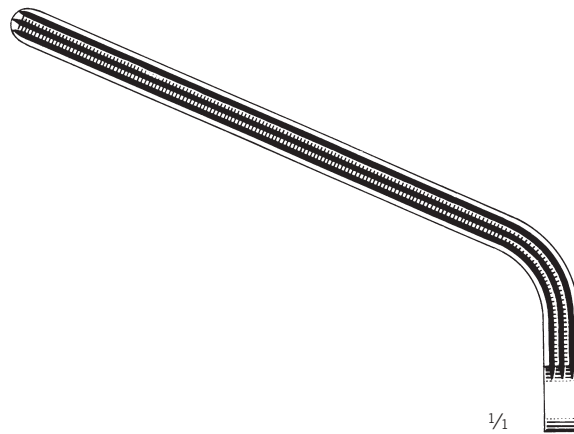

24-432-25-07
27,5 cm / 10 7/8"

Aneurysmaklemmen

Aneurysm Clamps

Pinzas para aneurisma

Pinces-clamps pour anévrisme

Pinze per aneurisma

Atrauma



1/2

De Bakey-Bahnson
24-433-23-07 -
24-433-26-07

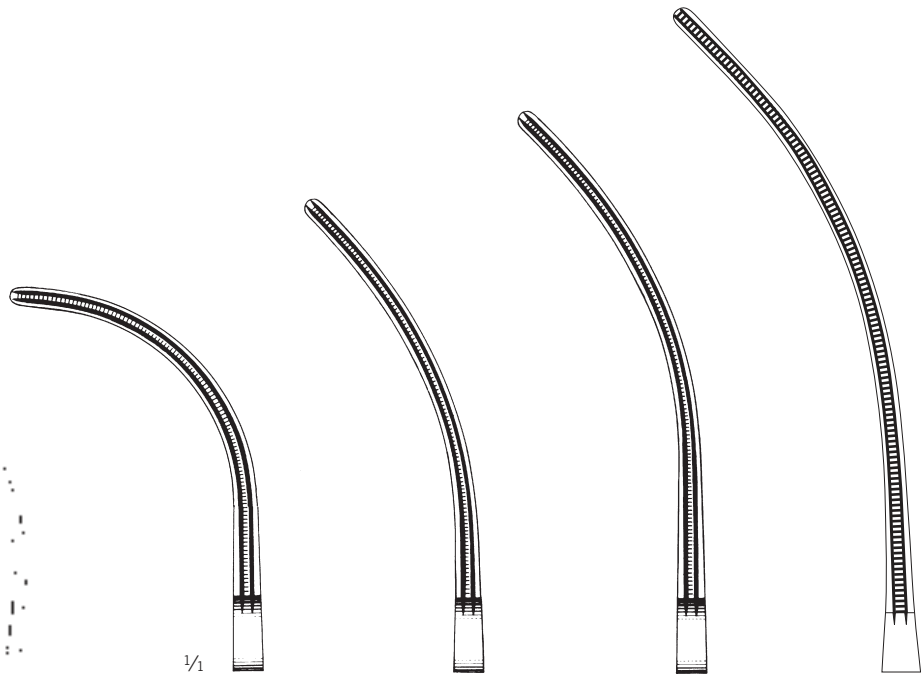

1/1

24-433-23-07
23,5 cm / 9 2/8"

24-433-24-07
24,5 cm / 9 5/8"

24-433-25-07
25,5 cm / 10"

24-433-26-07
26,5 cm / 10 4/8"

Mehrzweck-Gefäßklemmen

Multi purpose Vascular Clamps
 Pinzas vasculares de usos múltiples
 Pincas vasculaires universelles
 Pinze vascolari universali

Herz-, Thorax- und Gefäßchirurgie

Cardio Thoracic and Vascular Surgery
 Cirugía cardíaca, torácica y vascular
 Chirurgie cardiaque, thoracique et vasculaire
 Chirurgia cardiaca, toracica e vascolare

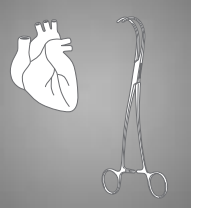

Atrauma



1/2

Potts
 24-434-21-07 -
 24-434-31-07

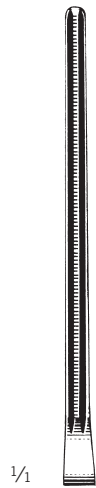

1/1

24-434-21-07
 21,5 cm / 8 4/8"



24-434-23-07
 23,5 cm / 9 2/8"



24-434-27-07
 27 cm / 10 5/8"



24-434-31-07
 31,5 cm / 12 3/8"



1/2

Potts
 24-435-21-07 -
 24-435-31-07



1/1

24-435-21-07
 21 cm / 8 2/8"

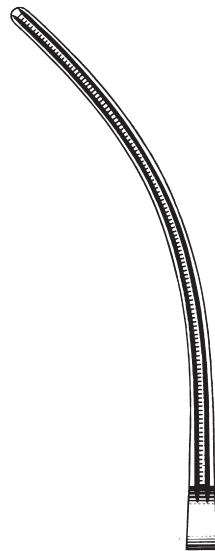

24-435-23-07
 23 cm / 9"

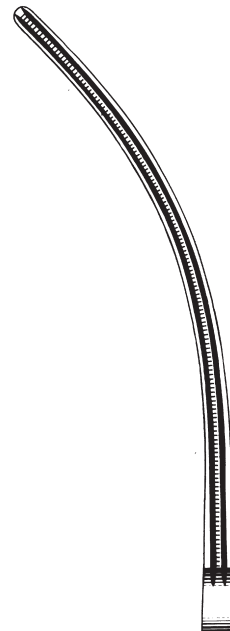

24-435-27-07
 26 cm / 10 2/8"

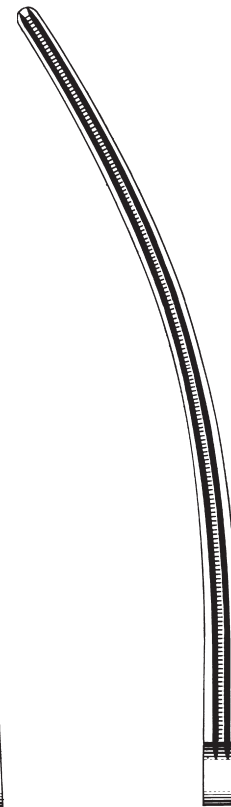

24-435-31-07
 31 cm / 12 2/8"

Mehrzweck-Gefäßklemmen

Multi purpose Vascular Clamps
Pinzas vasculares de usos múltiples
Pinces vasculaires universelles
Pinze vascolari universali

Atrauma

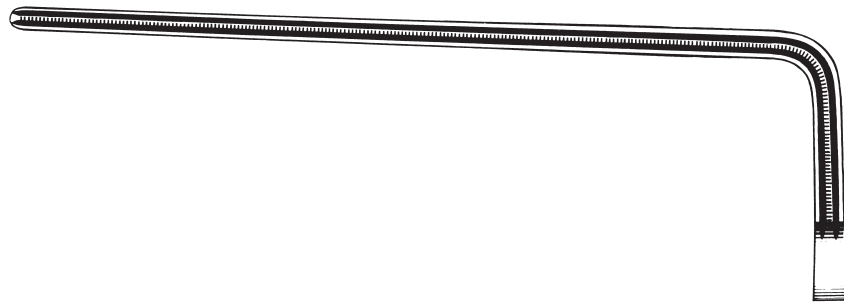

24-436-27-07
27,5 cm / 10 ⁵/₈"



24-436-23-07
23 cm / 9"



1/2

De Bakey
24-436-18-07 -
24-436-27-07

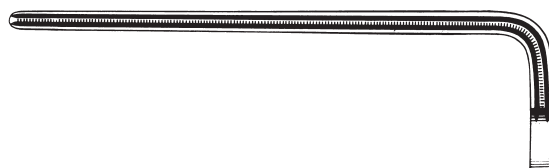

24-436-19-07
20 cm / 7 ⁷/₈"

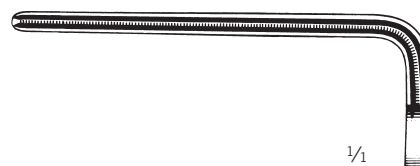

1/1

24-436-18-07
19 cm / 7 ⁴/₈"

Mehrzweck-Gefäßklemmen

Multi purpose Vascular Clamps
Pinzas vasculares de usos múltiples
Pincas vasculaires universelles
Pinze vascolari universali

Herz-, Thorax- und Gefäßchirurgie

Cardio Thoracic and Vascular Surgery
Cirugía cardíaca, torácica y vascular
Chirurgie cardiaque, thoracique et vasculaire
Chirurgia cardiaca, toracica e vascolare

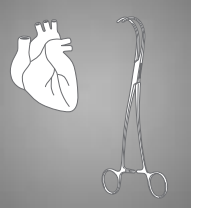

Atrauma

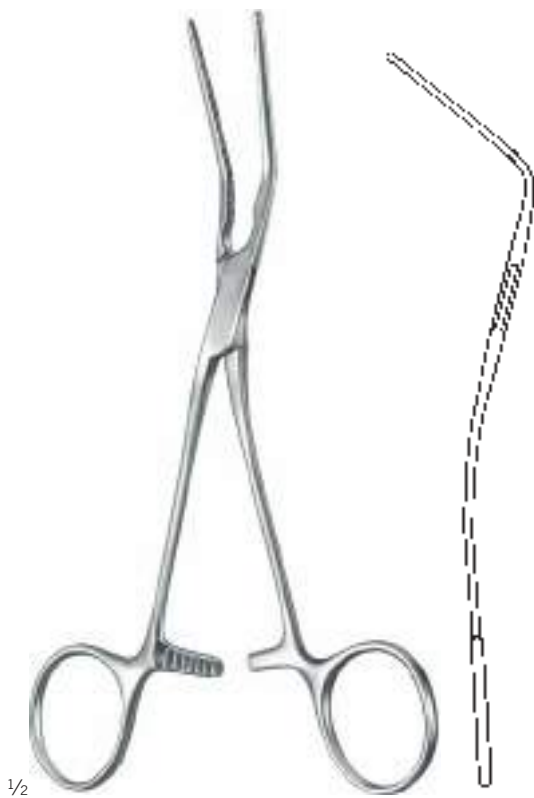
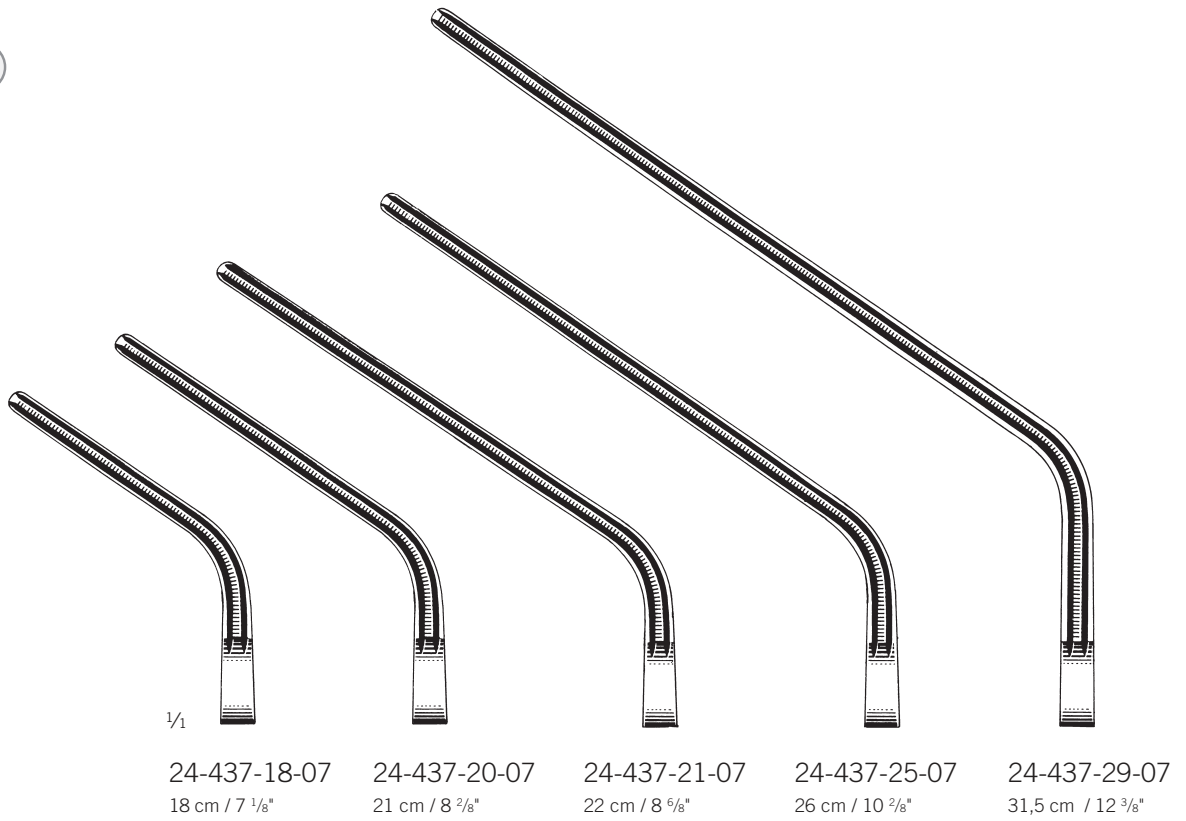

De Bakey
24-437-18-07 -
24-437-29-07

Arterienklemmen

Haemostatic Forceps
Pinzas hemostáticas
Pincas hémostatiques
Pinze emostatiche

Atrauma



De Bakey-Mosquito
24-438-12-07 -
24-439-12-07
12,5 cm / 4 7/8"



1/1

24-438-12-07



24-439-12-07

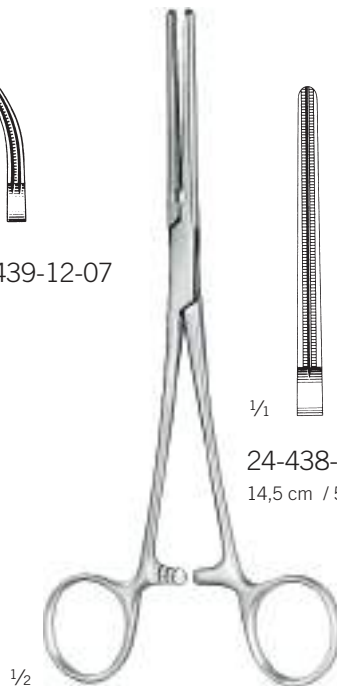

De Bakey-Pean
24-438-14-07 -
24-438-20-07

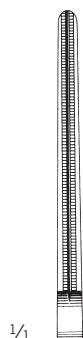

1/1

24-438-14-07
14,5 cm / 5 6/8"

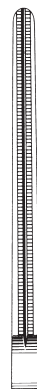

24-438-16-07
16,5 cm / 6 4/8"

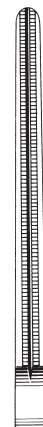

24-438-18-07
18,5 cm / 7 2/8"

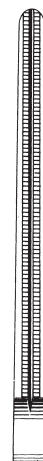

24-438-20-07
20,5 cm / 8 1/8"



De Bakey-Pean
24-439-14-07 -
24-439-20-07

1/1

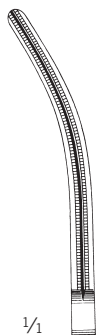

1/1

24-439-14-07
14,5 cm / 5 6/8"

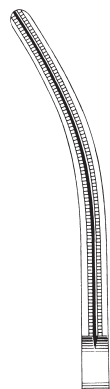

24-439-16-07
16,5 cm / 6 4/8"

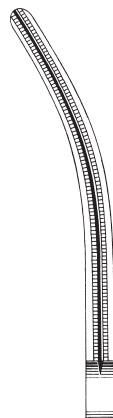

24-439-18-07
18,5 cm / 7 2/8"

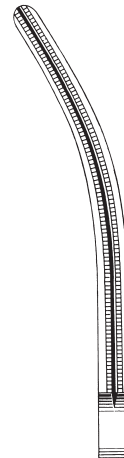

24-439-20-07
20 cm / 7 7/8"

Mehrzweck-Gefäßklemmen

Multi purpose Vascular Clamps
Pinzas vasculares de usos múltiples
Pinces vasculaires universelles
Pinze vascolari universali

Herz-, Thorax- und Gefäßchirurgie

Cardio Thoracic and Vascular Surgery
Cirugía cardíaca, torácica y vascular
Chirurgie cardiaque, thoracique et vasculaire
Chirurgia cardiaca, toracica e vascolare

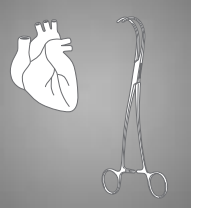

Atrauma



1/1

1/2

De Bakey
24-440-17-07
17,5 cm / 6 7/8"



1/2

De Bakey
24-441-16-07 -
24-445-15-07

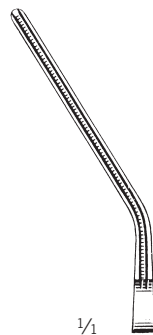

1/1

24-441-16-07
16,5 cm / 6 4/8"

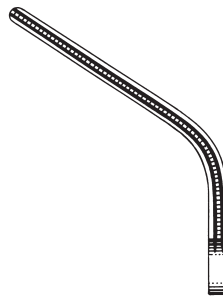

24-443-15-07
16 cm / 6 2/8"

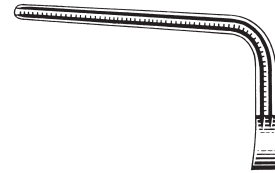

24-445-15-07
15 cm / 5 7/8"

Mehrzweck-Gefäßklemmen

Multi purpose Vascular Clamps
 Pinzas vasculares de usos múltiples
 Pinces vasculaires universelles
 Pinze vascolari universali

Atrauma



De Bakey
 24-447-17-07
 16,5 cm / 6 1/8"



1/1



Glover
 24-449-17-07
 17 cm / 6 5/8"



1/1



Glover
 24-451-17-07 -
 24-451-26-07

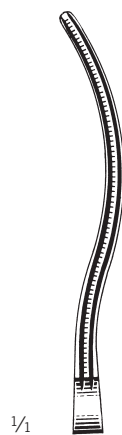

1/1

24-451-17-07
 17,5 cm / 6 7/8"



24-451-21-07
 21 cm / 8 2/8"



24-451-26-07
 26 cm / 10 2/8"

Anastomosenklemmen

Anastomosis Clamps
Pinzas para anastomosis
Pincas pour anastomose
Pinze per anastomosi

Herz-, Thorax- und Gefäßchirurgie

Cardio Thoracic and Vascular Surgery
Cirugía cardíaca, torácica y vascular
Chirurgie cardiaque, thoracique et vasculaire
Chirurgia cardiaca, toracica e vascolare

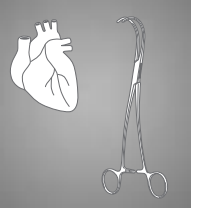

Atrauma

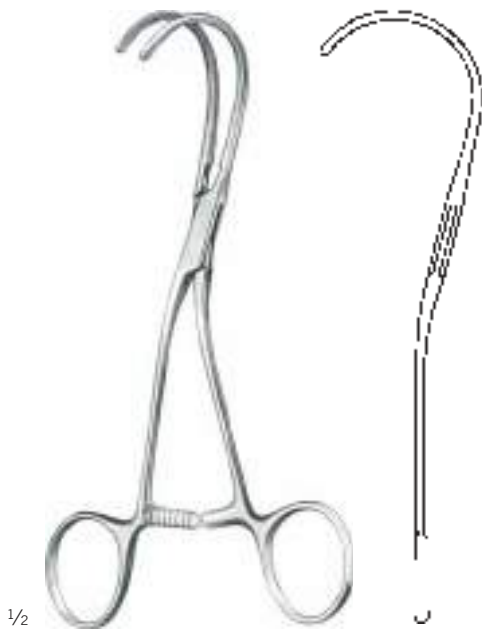

1/2

De Bakey
24-453-16-07 -
24-455-17-07
16,5 cm / 6 4/8"

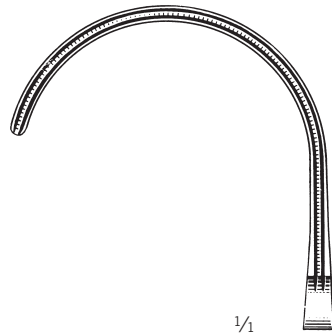

1/1

24-453-16-07

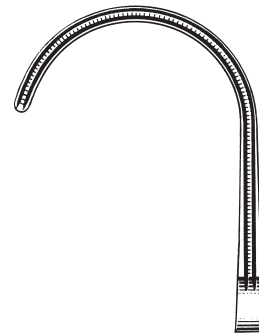

24-455-17-07

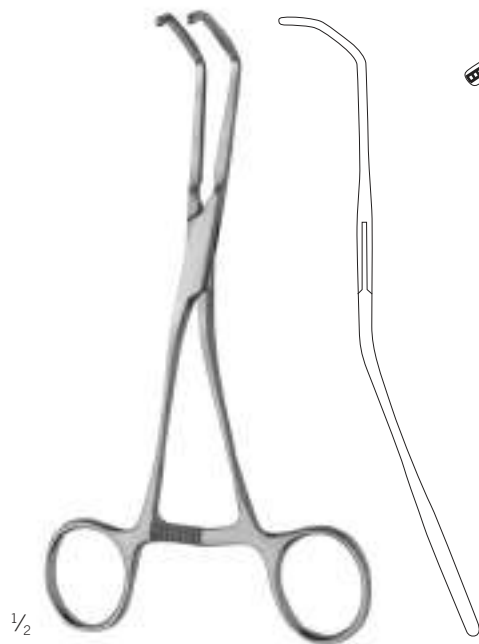

1/2

De Bakey-Reynolds
24-454-16-07 -
24-454-17-07

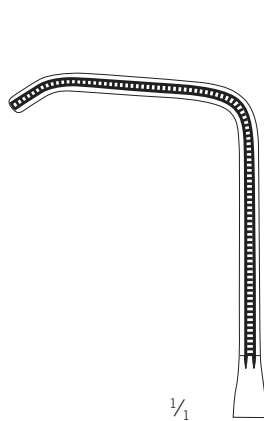

1/1

24-454-16-07
16,5 cm / 6 4/8"

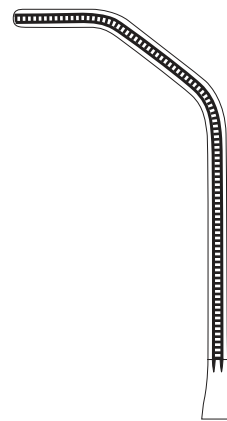

24-454-17-07
17,5 cm / 6 5/8"

Anastomosenklemmen

Anastomosis Clamps
 Pinzas para anastomosis
 Pinces pour anastomose
 Pinze per anastomosi

Atrauma



1/2



1/1

Fig. 1
 24-456-16-07
 16,5 cm / 6 4/8"



Fig. 2
 24-456-17-07
 17 cm / 6 6/8"

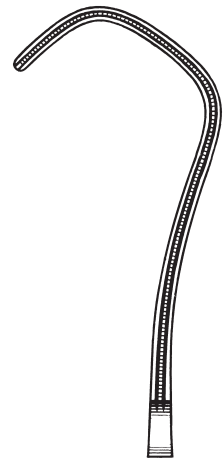

Fig. 3
 24-456-18-07
 17,5 cm / 6 5/8"

Derra

24-456-16-07 -
 24-456-18-07



1/2

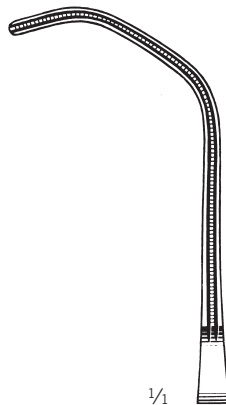

1/1

24-457-17-07
 17 cm / 6 6/8"

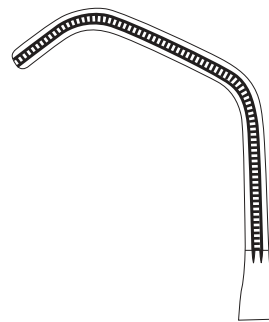

24-457-19-07
 19 cm / 7 4/8"

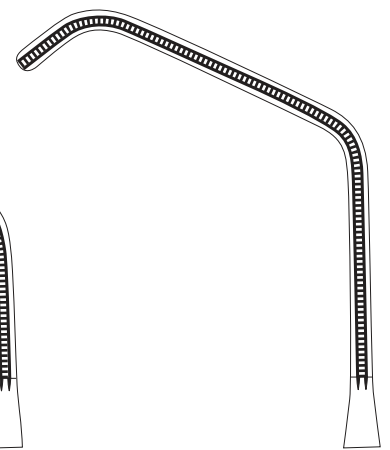

24-457-21-07
 21 cm / 8 2/8"

De Bakey-Beck
 24-457-17-07 -
 24-457-21-07

Kinder-Gefäßklemmen

Pediatric Vascular Clamps
Pinzas vasculares pediátricas
Pincers vasculaires pédiatriques
Pinze vascolari pediatriche

Herz-, Thorax- und Gefäßchirurgie

Cardio Thoracic and Vascular Surgery
Cirugía cardíaca, torácica y vascular
Chirurgie cardiaque, thoracique et vasculaire
Chirurgia cardiaca, toracica e vascolare

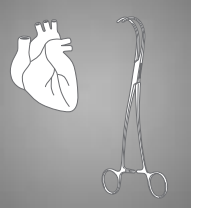

Atrauma



24-458-12-07
13 cm / 5 1/8"

24-458-11-07
13 cm / 5 1/8"

1/1
24-458-10-07
10 cm / 3 7/8"



1/2
De Bakey
24-458-10-07 -
24-458-12-07

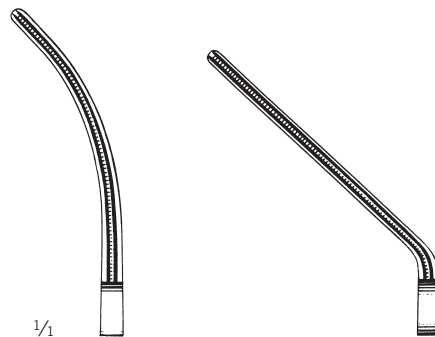

24-459-13-07

1/1
24-459-12-07



1/2
De Bakey
24-459-12-07 -
24-459-13-07
12,5 cm / 4 7/8"

Kinder-Gefäßklemmen

Pediatric Vascular Clamps

Pinzas vasculares pediátricas

Pinces vasculaires pédiatriques

Pinze vascolari pediatriche

Ti

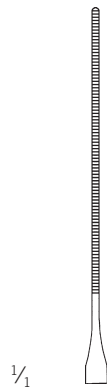

24-460-01-09
13 cm / 5 1/8"

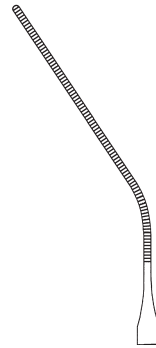

24-460-02-09
12,5 cm / 4 7/8"

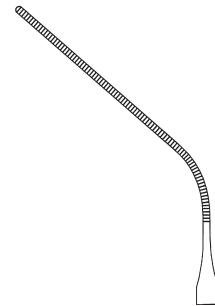

24-460-03-09
12 cm / 4 6/8"



Castañeda
24-460-01-09 -
24-460-08-09

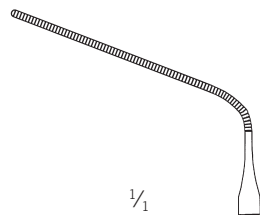

24-460-04-09
12 cm / 4 6/8"



24-460-05-09
11 cm / 4 3/8"

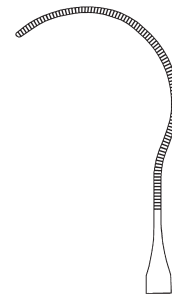

24-460-08-09
12 cm / 4 6/8"

Kinder-Gefäßklemmen

Pediatric Vascular Clamps
Pinzas vasculares pediátricas
Pincas vasculaires pédiatriques
Pinze vascolari pediatriche

Herz-, Thorax- und Gefäßchirurgie

Cardio Thoracic and Vascular Surgery
Cirugía cardíaca, torácica y vascular
Chirurgie cardiaque, thoracique et vasculaire
Chirurgia cardiaca, toracica e vascolare

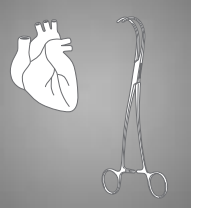

Ti

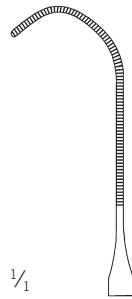

$\frac{1}{1}$

24-460-06-09

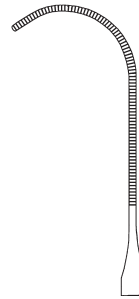

24-460-07-09

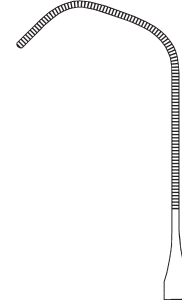

24-460-09-09



$\frac{1}{2}$

Castañeda
24-460-06-09 -
24-460-11-09
15 cm / 5 $\frac{7}{8}$ "

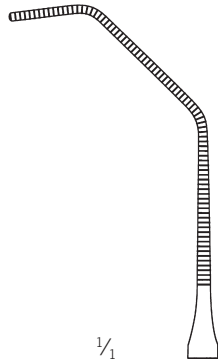

$\frac{1}{1}$

24-460-10-09

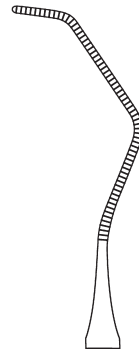

24-460-11-09

Kinder-Gefäßklemmen

Pediatric Vascular Clamps

Pinzas vasculares pediátricas

Pinces vasculaires pédiatriques

Pinze vascolari pediatriche

Atrauma

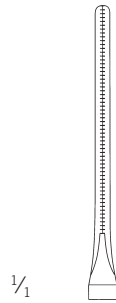

1/1

24-461-01-09
13,5 cm / 5 3/8"

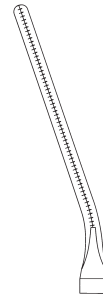

24-461-02-09
13,5 cm / 5 3/8"

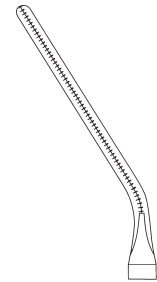

24-461-03-09
13 cm / 5 1/8"

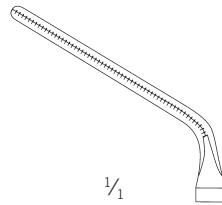

1/1

24-461-04-09
12,5 cm / 4 7/8"

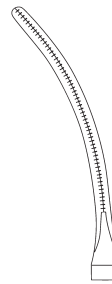

24-461-05-09
13,5 cm / 5 3/8"

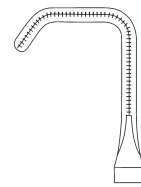

24-461-06-09
12 cm / 4 6/8"

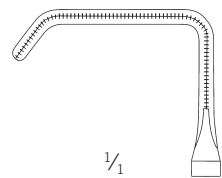

1/1

24-461-07-09
12 cm / 4 6/8"

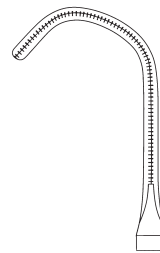

24-461-08-09
12,5 cm / 4 7/8"

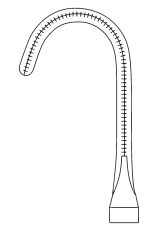

24-461-09-09
13 cm / 5 1/8"



1/2

De Bakey baby
24-461-01-09 -
24-461-11-09

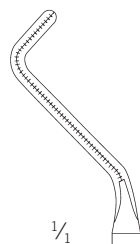

1/1

24-461-10-09
14 cm / 5 4/8"

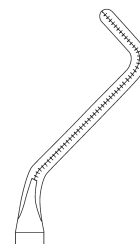

24-461-11-09
14 cm / 5 4/8"

Kinder-Gefäßklemmen

Pediatric Vascular Clamps
Pinzas vasculares pediátricas
Pincas vasculaires pédiatriques
Pinze vascolari pediatriche

Herz-, Thorax- und Gefäßchirurgie

Cardio Thoracic and Vascular Surgery
Cirugía cardíaca, torácica y vascular
Chirurgie cardiaque, thoracique et vasculaire
Chirurgia cardiaca, toracica e vascolare

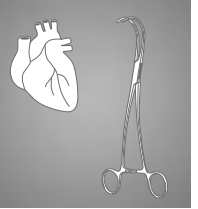

Atrauma



1/2

Cooley
24-461-30-09 -
24-461-31-09
14 cm / 5 4/8"

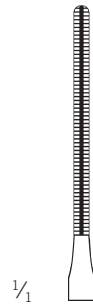

1/1

24-461-30-09

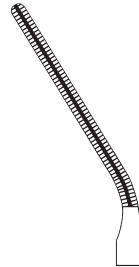

24-461-31-09



1/2

Cooley
24-461-32-09
14 cm / 5 4/8"

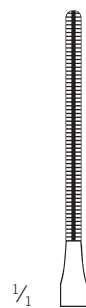

1/1

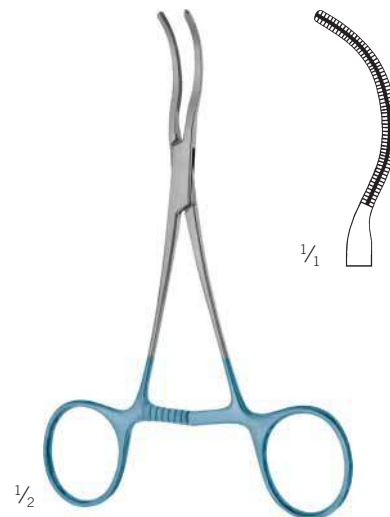

1/2

Cooley
24-461-33-09
13,5 cm / 5 3/8"



1/1

Kinder-Gefäßklemmen

Pediatric Vascular Clamps

Pinzas vasculares pediátricas

Pinces vasculaires pédiatriques

Pinze vascolari pediatriche

Atrauma

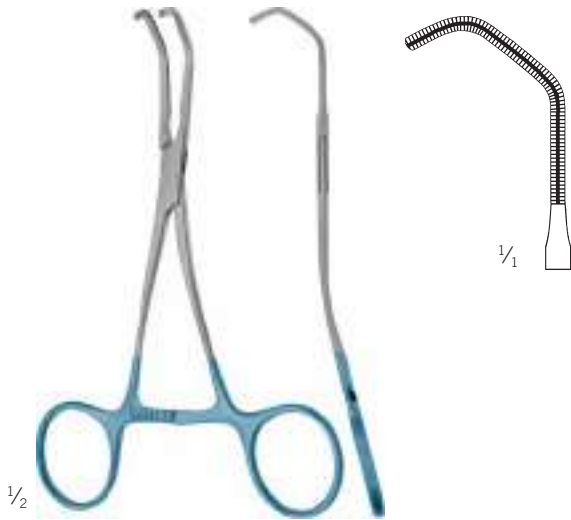

Cooley
24-461-34-09
13,5 cm / 5 3/8"



Cooley
24-461-35-09 -
24-461-37-09
11,5 cm / 4 4/8"

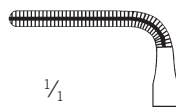

24-461-35-09



24-461-36-09



24-461-37-09

Kinder-Gefäßklemmen

Pediatric Vascular Clamps
 Pinzas vasculares pediátricas
 Pincas vasculaires pédiatriques
 Pinze vascolari pediatriche

Herz-, Thorax- und Gefäßchirurgie

Cardio Thoracic and Vascular Surgery
 Cirugía cardíaca, torácica y vascular
 Chirurgie cardiaque, thoracique et vasculaire
 Chirurgia cardiaca, toracica e vascolare

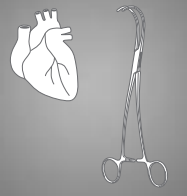

Atrauma

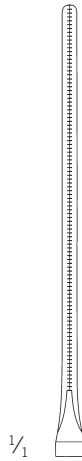

1/2

De Bakey baby
 24-461-50-09
 16,5 cm / 6 4/8"

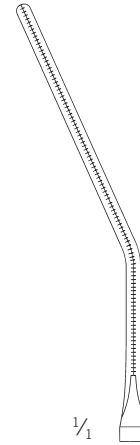

1/2

De Bakey baby
 24-461-51-09
 16 cm / 6 2/8"

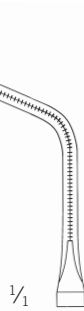
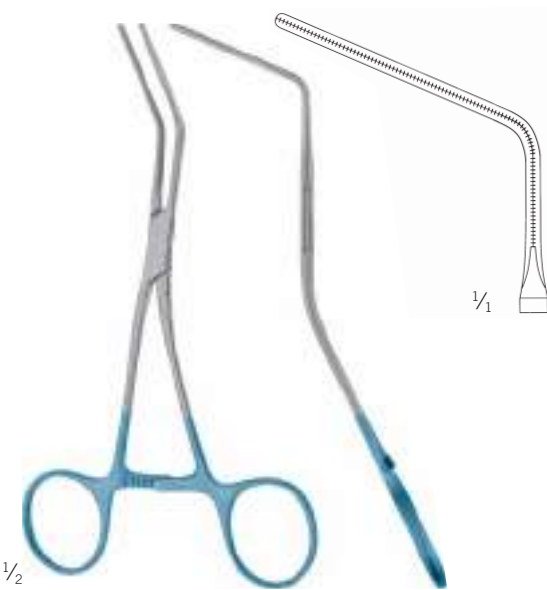

1/2

De Bakey baby
 24-461-52-09
 15 cm / 5 7/8"

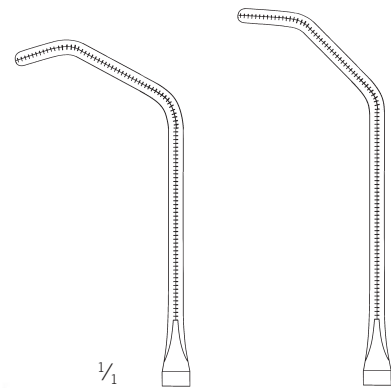

1/2

De Bakey baby
 24-461-53-09 -
 24-461-54-09
 15 cm / 5 7/8"

1/2

24-461-53-09

24-461-54-09

24

Kinder-Gefäßklemmen

Pediatric Vascular Clamps

Pinzas vasculares pediátricas

Pinces vasculaires pédiatriques

Pinze vascolari pediatriche

Atrauma



1/2

De Bakey
24-462-01-09 -
24-462-03-09

1/1

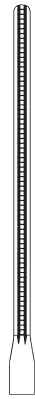

24-462-01-09
13 cm / 5 1/8"

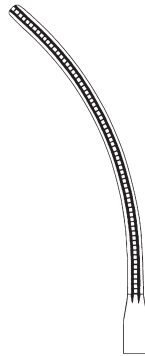

24-462-02-09
12,5 cm / 4 7/8"

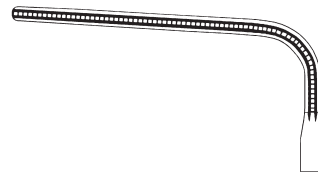

24-462-03-09
10 cm / 3 7/8"



1/2

De Bakey
24-462-04-09 -
24-462-05-09
12,5 cm / 4 7/8"

1/1

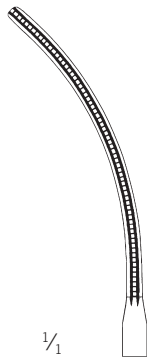

24-462-04-09

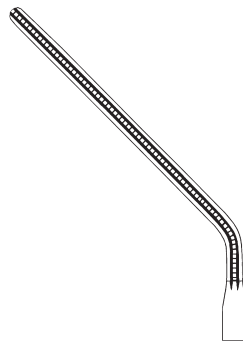

24-462-05-09

Aortaklemmen

Aortic Clamps
Pinzas aórticas
Pinces-clamps pour aorte
Pinze per aorta

Herz-, Thorax- und Gefäßchirurgie

Cardio Thoracic and Vascular Surgery
Cirugía cardíaca, torácica y vascular
Chirurgie cardiaque, thoracique et vasculaire
Chirurgia cardiaca, toracica e vascolare

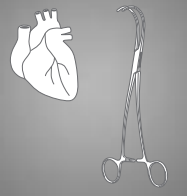

Atrauma

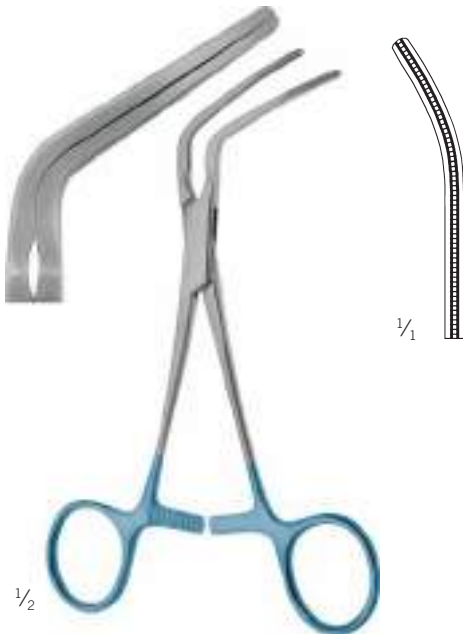

Subramanian
24-462-20-09
15,5 cm / 6 1/8"

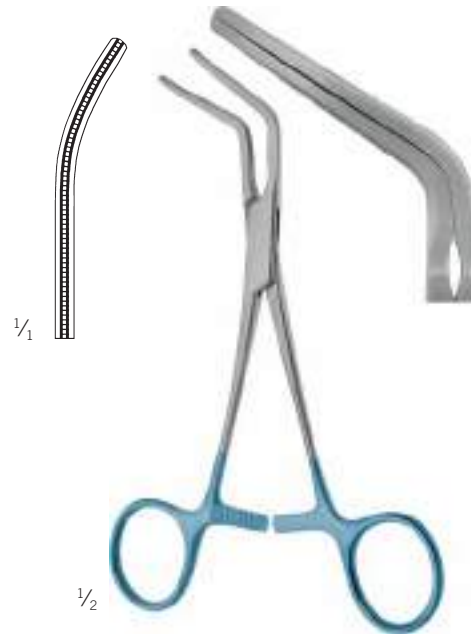

Subramanian
24-462-21-09
15,5 cm / 6 1/8"

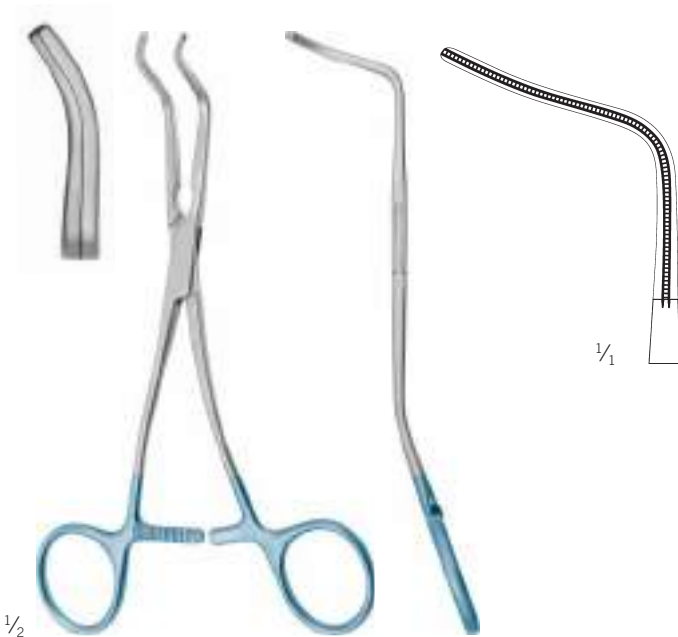

Subramanian
24-462-22-09
16,5 cm / 6 5/8"



De Bakey-Beck
24-462-23-09
16 cm / 6 3/8"

Anastomosenklemmen

Anastomosis Clamps
Pinzas para anastomosis
Pinces-clamps pour anastomose
Pinze per anastomosi

Atrauma



1/2

De Bakey-Derra
24-462-40-09 -
24-462-42-09
16,5 cm / 6 1/8"

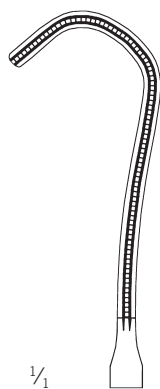

1/1

24-462-40-09

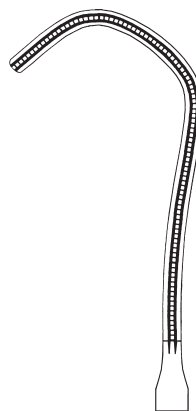

24-462-41-09

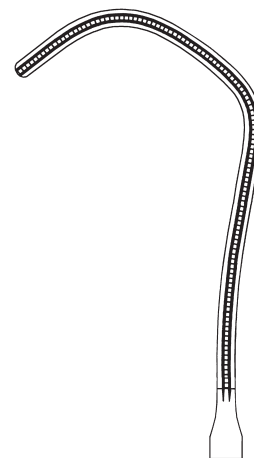

24-462-42-09

Tangentialklammern

Tangential Occlusion Clamps

Pinzas para oclusión tangencial

Pinces-clamps pour occlusion tangentielle

Pinze per occlusione tangenziale

Herz-, Thorax- und Gefäßchirurgie

Cardio Thoracic and Vascular Surgery

Cirugía cardíaca, torácica y vascular

Chirurgie cardiaque, thoracique et vasculaire

Chirurgia cardiaca, toracica e vascolare

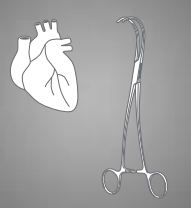

Atrauma

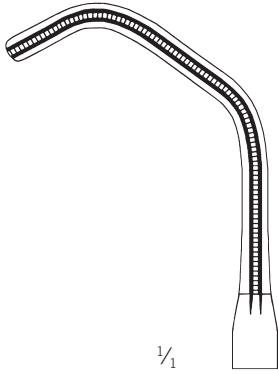

1/1

24-462-43-09

23,5 cm / 9 2/8"

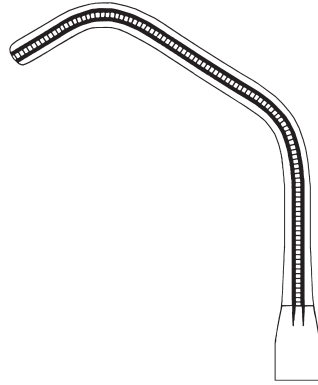

24-462-44-09

24 cm / 9 4/8"

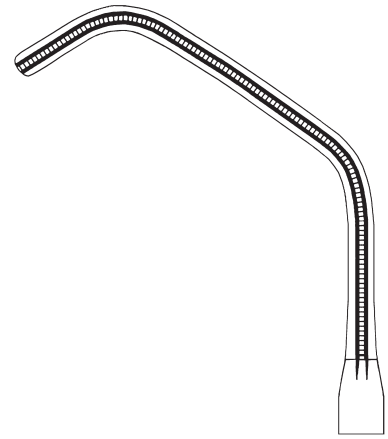

24-462-45-09

24,5 cm / 9 5/8"

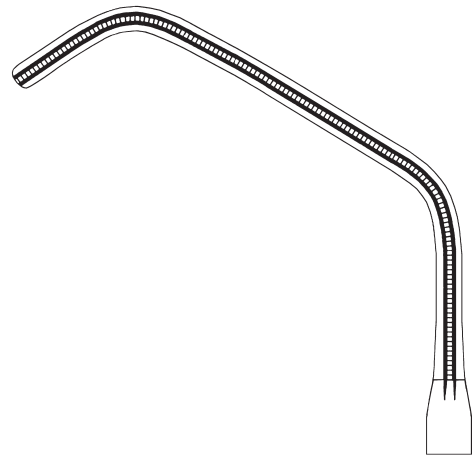

24-462-46-09

25 cm / 9 7/8"

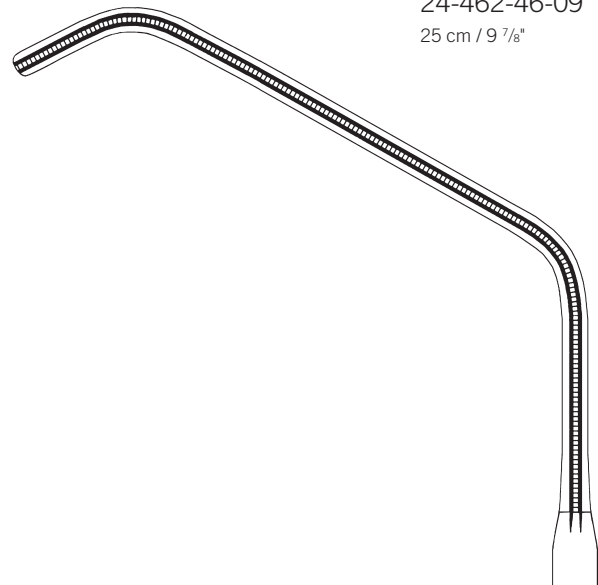

24-462-47-09

28,5 cm / 11 2/8"



1/2

De Bakey-Satinsky

24-462-43-09 -

24-462-47-09

Anastomosenklemmen

Anastomosis Clamps
Pinzas para anastomosis
Pinces-clamps pour anastomose
Pinze per anastomosi

Atrauma

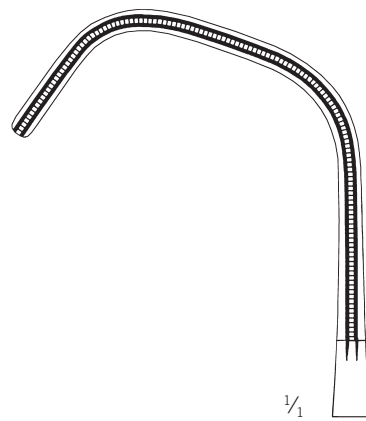

$\frac{1}{2}$

$\frac{1}{1}$

Lambert-Kay
24-462-48-09
19,5 cm / 7 $\frac{5}{8}$ "

Aortaklemmen

Aortic Clamps
Pinzas aórticas
Pinces-clamps pour aorte
Pinze per aorta

Herz-, Thorax- und Gefäßchirurgie

Cardio Thoracic and Vascular Surgery
Cirugía cardíaca, torácica y vascular
Chirurgie cardiaque, thoracique et vasculaire
Chirurgia cardiaca, toracica e vascolare

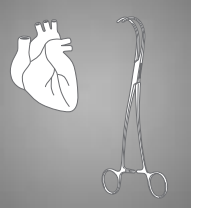

Atrauma



1/2

De Bakey
24-462-60-09 -
24-462-63-09

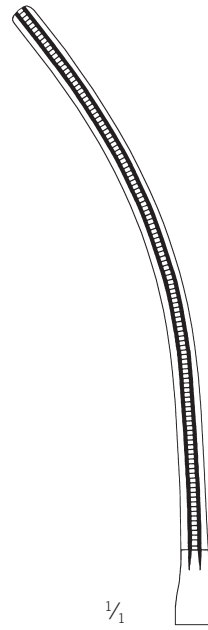

1/1

24-462-60-09
26 cm / 10 3/8"

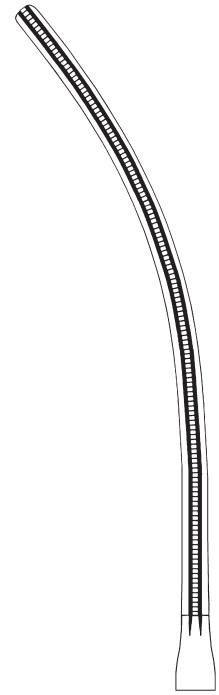

24-462-61-09
26,5 cm / 10 4/8"

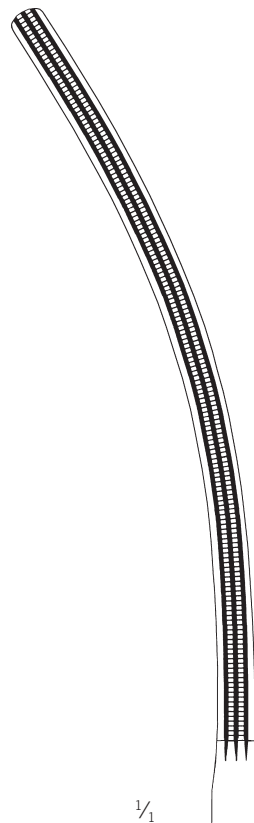

1/1

24-462-62-09
31 cm / 12 3/8"

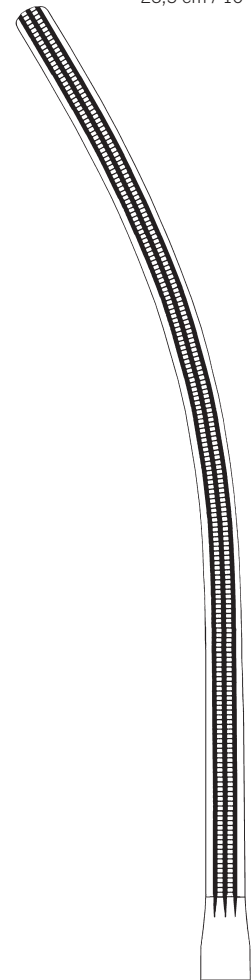

24-462-63-09
33 cm / 13"

Gefäßpinzetten

Vascular Forceps

Pinzas de disección vascular

Pinces à dissection vasculaires

Pinze per dissezione vascolari

Atrauma



1/2

Cooley
24-464-16-07 -
24-464-20-07

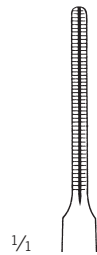

1/1

2,0 mm
24-464-16-07
16 cm / 6 2/8"

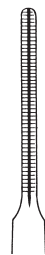

2,0 mm
24-464-20-07
20 cm / 7 7/8"

Kinder-Gefäßklemmen

Pediatric Vascular Clamps
 Pinzas vasculares pediátricas
 Pincas vasculaires pédiatriques
 Pinze vascolari pediatriche

Herz-, Thorax- und Gefäßchirurgie

Cardio Thoracic and Vascular Surgery
 Cirugía cardíaca, torácica y vascular
 Chirurgie cardiaque, thoracique et vasculaire
 Chirurgia cardiaca, toracica e vascolare

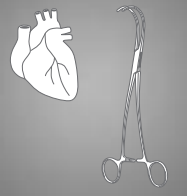

Atrauma

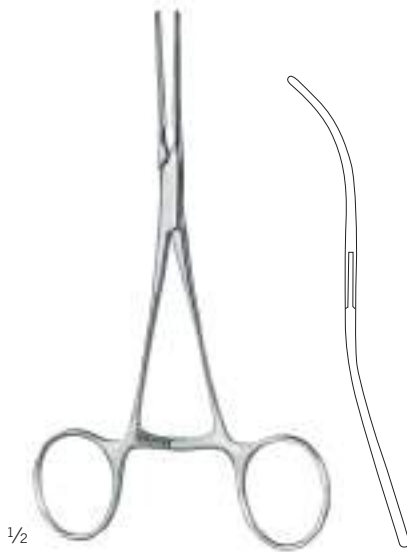

Cooley
 24-466-01-07 -
 24-466-06-07

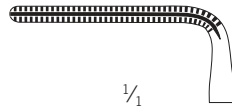

$\frac{1}{1}$
 24-466-00-07
 11,5 cm / 4 $\frac{4}{8}$ "



24-466-01-07
 14,5 cm / 5 $\frac{6}{8}$ "

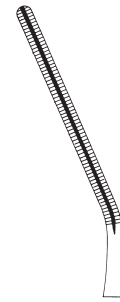

24-466-02-07
 14,5 cm / 5 $\frac{6}{8}$ "

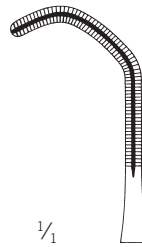

$\frac{1}{1}$
 24-466-04-07
 14 cm / 5 $\frac{4}{8}$ "



24-466-05-07
 14,5 cm / 5 $\frac{6}{8}$ "

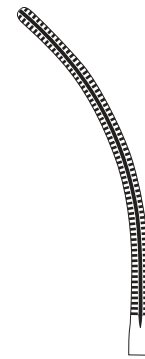

24-466-06-07
 12,5 cm / 4 $\frac{7}{8}$ "



Cooley
 24-466-03-07
 14,5 cm / 5 $\frac{6}{8}$ "

Anastomosenklemmen, Mehrzweck-Gefäßklemmen

Anastomosis Clamps, Multi purpose Vascular Clamps

Pinzas para anastomosis, Pinzas vasculares de usos múltiples

Pinces-clamps pour anastomose, Pinces vasculaires universelles

Pinze per anastomosi, Pinze vascolari universali

Atrauma

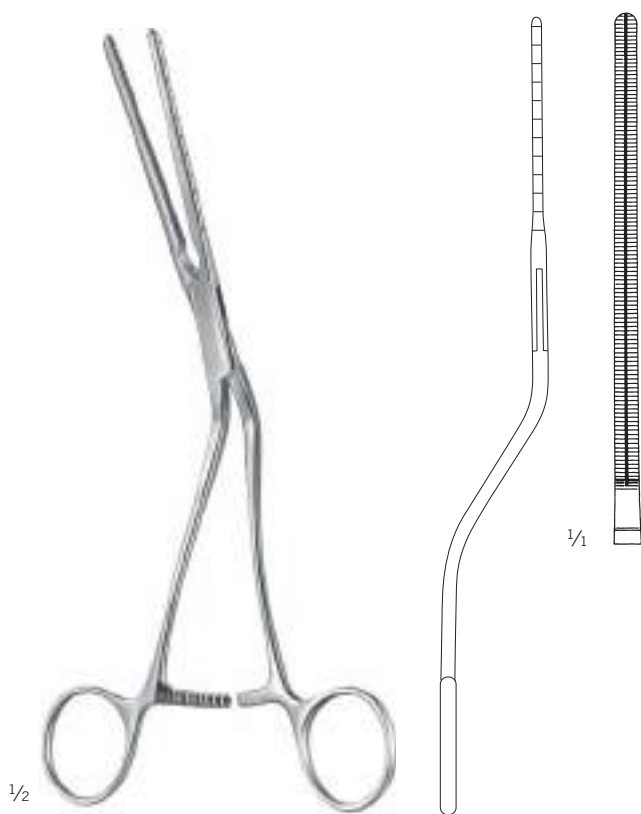

1/2

1/1

Cooley
24-467-21-07
22 cm / 8 5/8"

Iliacaklemme
Iliac Clamp
Pinza para iliaca
Pince-clamps iliaque
Pinza iliaca



1/2

1/1

Cooley
24-468-17-07
17 cm / 6 5/8"

Anastomosenklemmen, Mehrzweck-Gefäßklemmen

Anastomosis Clamps, Multi purpose Vascular Clamps

Pinzas para anastomosis, Pinzas vasculares de usos múltiples

Pinces-clamps pour anastomose, Pinces vasculaires universelles

Pinze per anastomosi, Pinze vascolari universali

Herzchirurgie

Cardio Thoracic and Vascular Surgery

Cirugía cardíaca, torácica y vascular

Chirurgie cardiaque, thoracique et vasculaire

Chirurgia cardiaca, toracica e vascolare

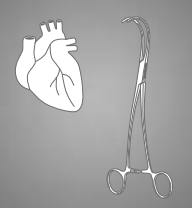

Atrauma



Cooley
24-469-20-07
20 cm / 7 7/8"

Carotisklemme
Carotid Clamp
Pinza para carótida
Pince-clamps pour carotide
Pinza per carotis

Cooley-Parry
24-469-18-07 -
24-469-26-07

24-469-18-07
18 cm / 7 1/8"

24-469-26-07
26 cm / 10 2/8"

24

Anastomosenklemmen, Mehrzweck-Gefäßklemmen

Anastomosis Clamps, Multi purpose Vascular Clamps

Pinzas para anastomosis, Pinzas vasculares de usos múltiples

Pinces-clamps pour anastomose, Pinces vasculaires universelles

Pinze per anastomosi, Pinze vascolari universali

Atrauma



1/2

Cooley
24-470-17-07
17 cm / 6 5/8"



1/2

Cooley
24-471-16-07
16 cm / 6 2/8"



1/2

Cooley
24-472-15-07 -
24-472-17-07

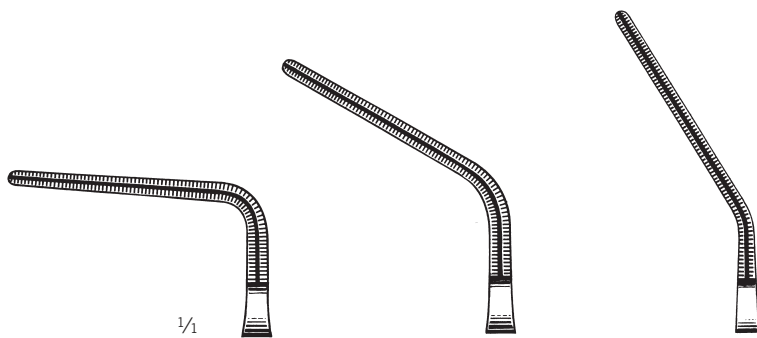

1/1

24-472-15-07
14,5 cm / 5 5/8"

24-472-16-07
16 cm / 6 2/8"

24-472-17-07
16,5 cm / 6 4/8"

Anastomosenklemmen

Anastomosis Clamps
Pinzas para anastomosis
Pinces-clamps pour anastomose
Pinze per anastomosi

Herz-, Thorax- und Gefäßchirurgie

Cardio Thoracic and Vascular Surgery
Cirugía cardíaca, torácica y vascular
Chirurgie cardiaque, thoracique et vasculaire
Chirurgia cardiaca, toracica e vascolare

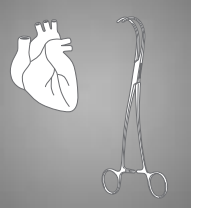

Atrauma



Cooley
24-473-17-07
17 cm / 6 5/8"

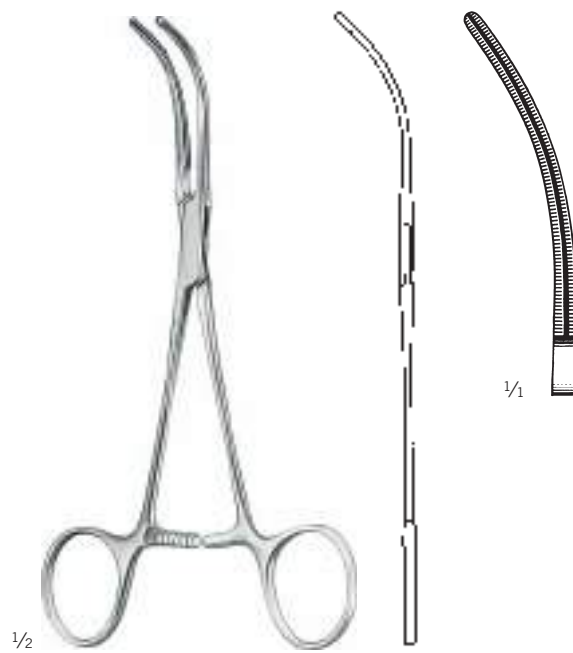

Cooley
24-474-17-07
17 cm / 6 5/8"

Anastomosenklemmen

Anastomosis Clamps
Pinzas para anastomosis
Pinces-clamps pour anastomose
Pinze per anastomosi

Atrauma

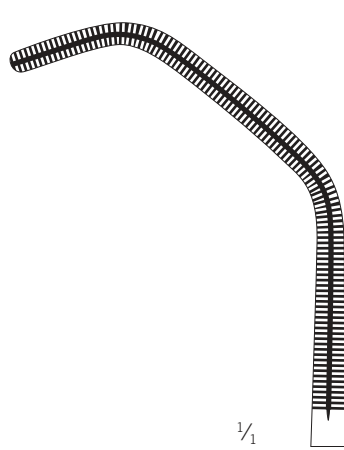

$\frac{1}{1}$

24-475-26-07
26,5 cm / 10 $\frac{4}{8}$ "

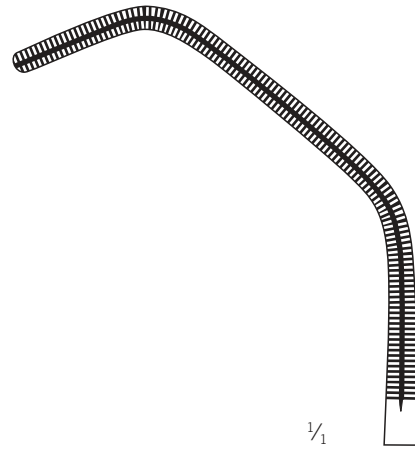

$\frac{1}{1}$

24-475-27-07
26,5 cm / 10 $\frac{4}{8}$ "

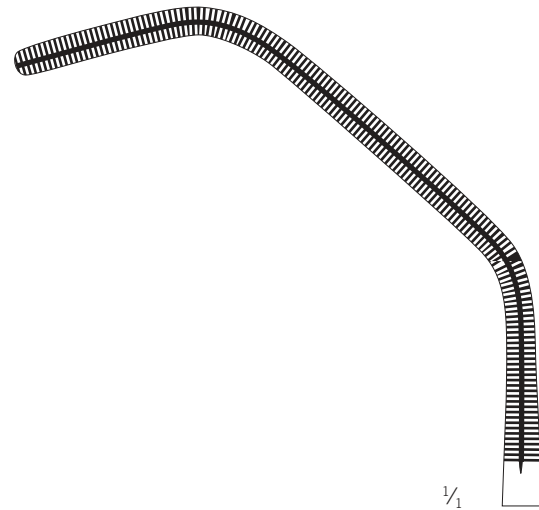

$\frac{1}{1}$

24-475-28-07
27,5 cm / 10 $\frac{6}{8}$ "



$\frac{1}{2}$

Cooley
24-475-26-07 -
24-475-28-07

Anastomosenklemmen

Anastomosis Clamps
Pinzas para anastomosis
Pinces-clamps pour anastomose
Pinze per anastomosi

Herz-, Thorax- und Gefäßchirurgie

Cardio Thoracic and Vascular Surgery
Cirugía cardíaca, torácica y vascular
Chirurgie cardiaque, thoracique et vasculaire
Chirurgia cardiaca, toracica e vascolare

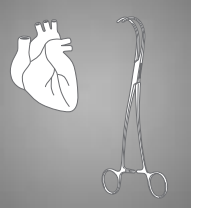

Atrauma



1/2

Cooley
24-476-17-07
17,5 cm / 6 7/8"

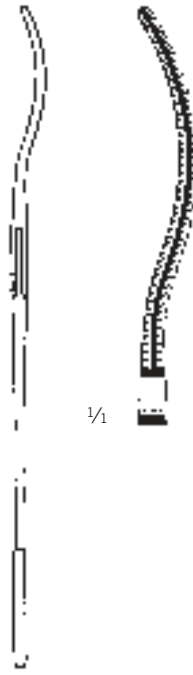

1/1



1/2

Cooley
24-477-16-07 -
24-477-17-07
16,5 cm / 6 4/8"

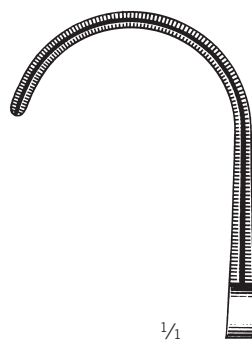

1/1

24-477-16-07



24-477-17-07

Anastomosenklemmen

Anastomosis Clamps
 Pinzas para anastomosis
 Pincers-clamps pour anastomose
 Pinze per anastomosi

Atrauma



1/2

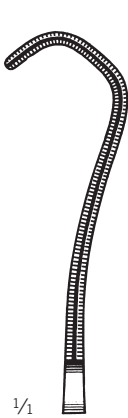

1/1

24-478-16-07
 16,5 cm / 6 4/8"

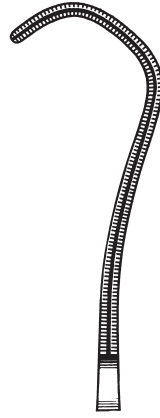

24-478-17-07
 17 cm / 6 6/8"

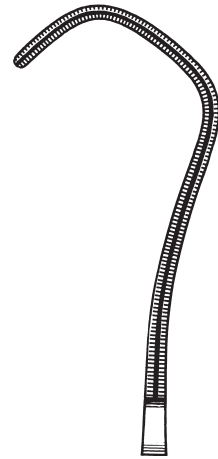

24-478-18-07
 17,5 cm / 6 7/8"

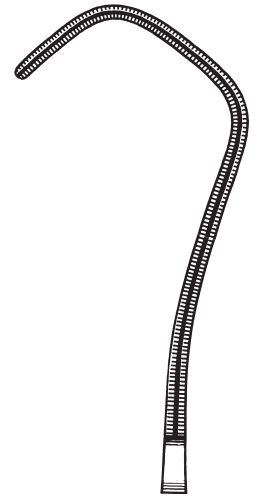

24-478-21-07
 21 cm / 8 2/8"

Cooley-Derra
 24-478-16-07 -
 24-478-21-07

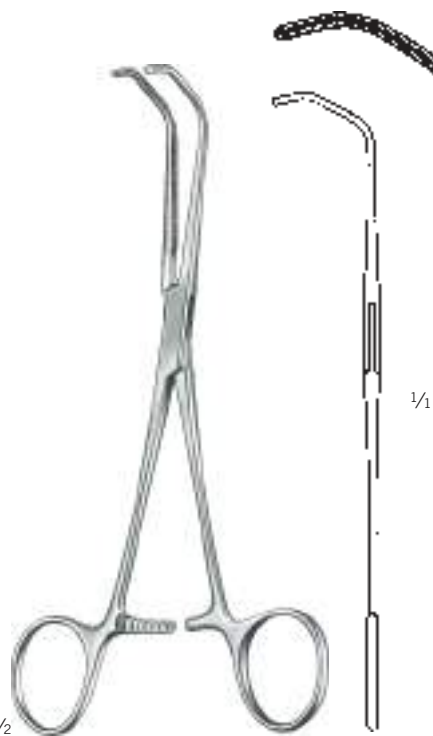

1/2

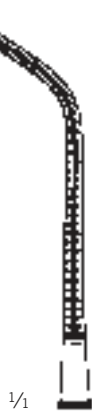

1/1

Cooley-Beck
 24-479-17-07
 17 cm / 6 6/8"



1/2

Allenberg Cobra
 24-480-23-07 -
 24-480-25-07

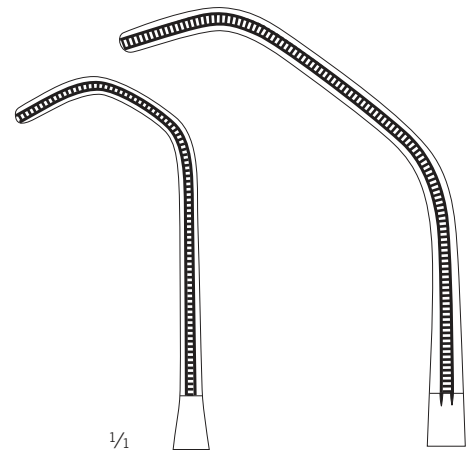

1/1

24-480-23-07
 23,5 cm / 9 2/8"

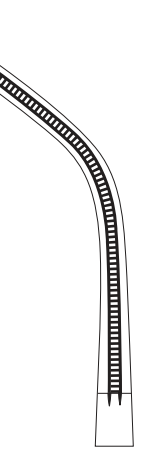

24-480-25-07
 26,5 cm / 10 3/8"

Aorta-Dilatatoren

Aortic Dilators
Dilatadores aórticos
Dilateurs pour aorte
Dilatatori per aorta

Herz-, Thorax- und Gefäßchirurgie

Cardio Thoracic and Vascular Surgery
Cirugía cardíaca, torácica y vascular
Chirurgie cardiaque, thoracique et vasculaire
Chirurgia cardiaca, toracica e vascolare

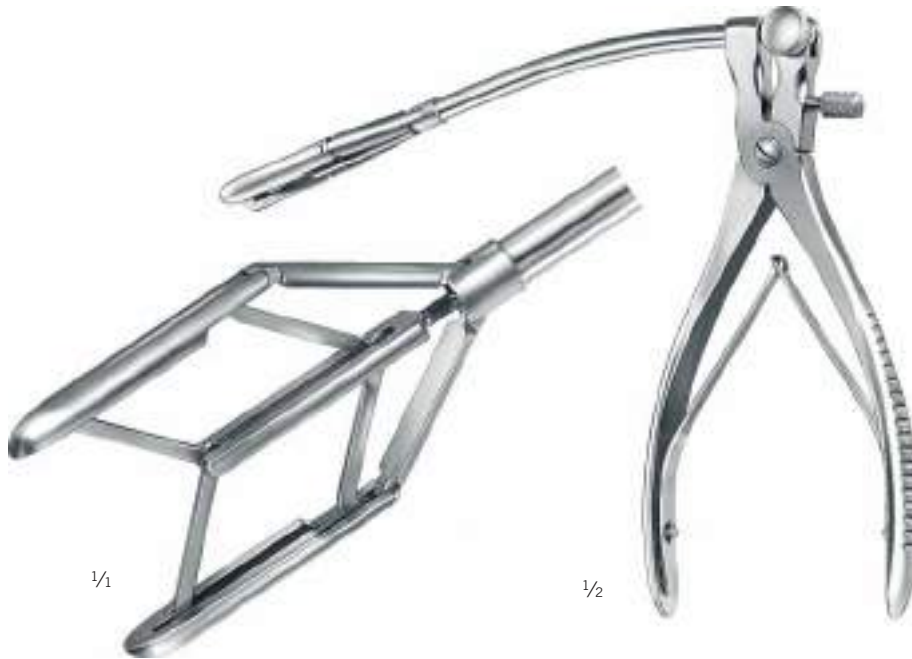
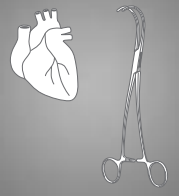

Tubbs 24-482-00-07

Spreizweite 8 - 42 mm, mit Feststellschraube
spreading 8 - 42 mm, with fixation screw
abertura 8 - 42 mm, con tornillo de ajuste
ouverture 8 - 42 mm, avec vis de fixation
apertura totale 8 - 42 mm, con vite di fissazione

für Mitralkstenosen
for mitral stenosis
para estenosis mitral
pour sténoses mitrales
per stenosi mitrali

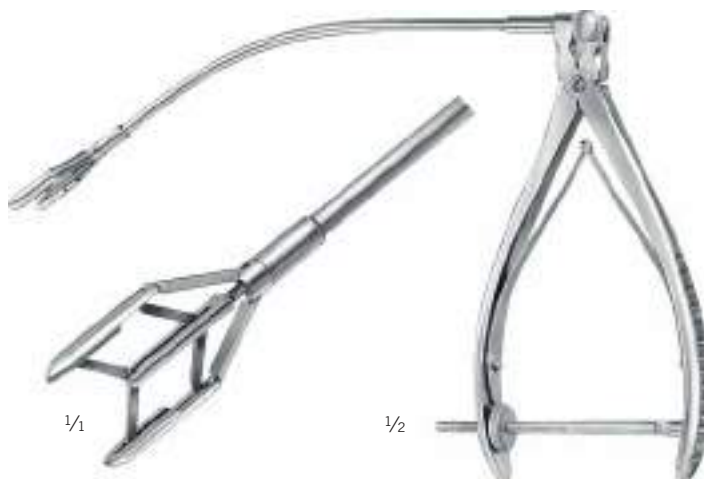

Cooley 24-484-00-07

Spreizweite 5 - 20 mm, mit Gewindesperre
spreading 5 - 20 mm, with thread fixation
abertura 5 - 20 mm, con fijación de rosca
ouverture 5 - 20 mm, avec fixation filetée
apertura totale 5 - 20 mm, con fissazione a filettatura

für Mitralkstenosen
for mitral stenosis
para estenosis mitral
pour sténoses mitrales
per stenosi mitrali

Gefäßdilatoren

Vascular Dilators

Dilatadores vasculares

Dilatateurs vasculaires

Dilatatori vascolari

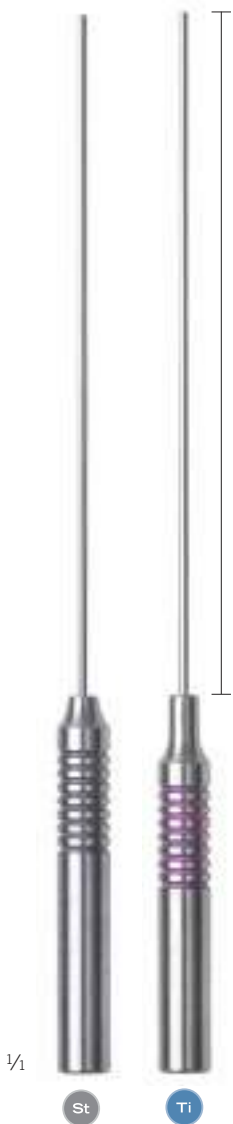

Nit

biegsam
malleable
maleable
malléable
malleabili

1/1



	Ø	0.5 mm	1.0 mm	1.5 mm
14 cm / 5 1/8"	St	24-506-05-01	24-506-10-01	24-506-15-01
	Ti	24-515-05-04	24-515-10-04	24-515-15-04
19 cm / 7 1/2"	St	24-507-05-01	24-507-10-01	24-507-15-01
	Ti	24-516-05-04	24-516-10-04	24-516-15-04

1/1

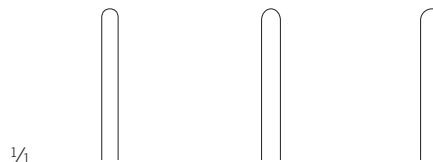

	Ø	2.0 mm	2.5 mm	3.0 mm
14 cm / 5 1/8"	St	24-506-20-01	24-506-25-01	24-506-30-01
	Ti	24-515-20-04	24-515-25-04	24-515-30-04
19 cm / 7 1/2"	St	24-507-20-01	24-507-25-01	24-507-30-01
	Ti	24-516-20-04	24-516-25-04	24-516-30-04

1/1

Cooley
24-506-05-01 -
24-516-30-04

Gefäßdilatoren

Vascular Dilators
Dilatadores vasculares
Dilateurs vasculaires
Dilatatori vascolari

Herz-, Thorax- und Gefäßchirurgie

Cardio Thoracic and Vascular Surgery
Cirugía cardíaca, torácica y vascular
Chirurgie cardiaque, thoracique et vasculaire
Chirurgia cardiaca, toracica e vascolare

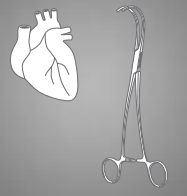

	Ø	0.5 mm	1.0 mm	1.5 mm	2.0 mm
14 cm / 5 1/8"	St	24-493-05-01	24-493-10-01	24-493-15-01	24-493-20-01
	Ti	24-509-05-04	24-509-10-04	24-509-15-04	24-509-20-04
19 cm / 7 1/2"	St	24-492-05-01	24-492-10-01	24-492-15-01	24-492-20-01
	Ti	24-510-05-04	24-510-10-04	24-510-15-04	24-510-20-04

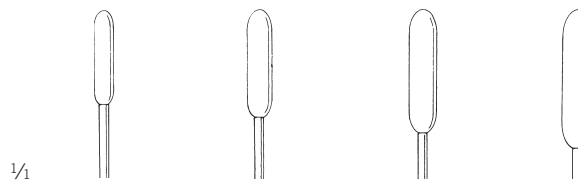

	Ø	2.5 mm	3.0 mm	3.5 mm	4.0 mm
14 cm / 5 1/8"	St	24-493-25-01	24-493-30-01	24-493-35-01	24-493-40-01
	Ti	24-509-25-04	24-509-30-04	24-509-35-04	24-509-40-04
19 cm / 7 1/2"	St	24-492-25-01	24-492-30-01	24-492-35-01	24-492-40-01
	Ti	24-510-25-04	24-510-30-04	24-510-35-04	24-510-40-04

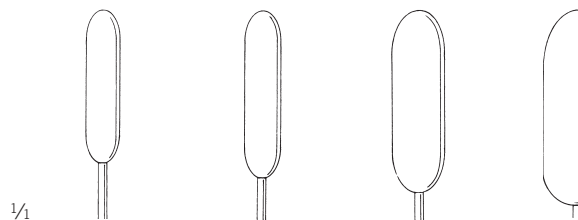

	Ø	4.5 mm	5.0 mm	7.0 mm	9.0 mm
14 cm / 5 1/8"	St	24-493-45-01	24-493-50-01		
	Ti	24-509-45-04	24-509-50-04		
19 cm / 7 1/2"	St	24-492-45-01	24-492-50-01	24-492-70-01	24-492-90-01
	Ti	24-510-45-04	24-510-50-04	24-510-70-04	24-510-90-04

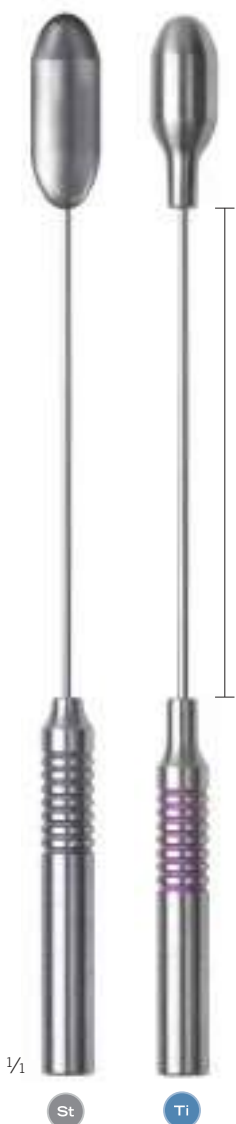

Nit

biegsam
malleable
maleable
malléable
malleabili

DeBakey
24-492-05-01 -
24-510-90-04

Tunnelier-Set

Tunneling Set

Juego para tunelar

Jeu pour tunneler

Set per tunnelare



1/4

Martin

24-502-00-01

Satz komplett mit 3 Schäften, 2 Griffen und 12 Aufsätzen im Lagerungsbehälter

complete set with 3 shafts, 2 handles and 12 tips in storage case

juego completo con 3 vástagos, 2 mangos y 12 cabezas en caja metálica

jeu complet avec 3 tiges, 2 manches et 12 embouts en boîte métal

Set completo, con 3 gambi, 2 manici con 12 raccordi in contenitore metallico

1/2



1/3



24-502-65-01

Schraubaufsatz für Venen

Vein Tip

Cabeza para venas

Embout pour veines

Tata adattatore veni

mit Knopf, Luer-Lock Ansatz
with button, Luer-Lock cone
con botón, cono Luer-Lock
avec bouton, cône Luer-Lock
con bottone, cono Luer-Lock

24-502-70-01

Luer-Schraubadapter

Luer Adaptor

Adaptador Luer

Adaptateur Luer

Adattatore Luer

Luer-Lock Ansatz
Luer-Lock cone
cono Luer-Lock
cône Luer-Lock
cono Luer-Lock

24-502-99-07

10 cm / 4"

Schrauben-schlüssel

Wrench

Llave horquilla

Tournevis

Giravite

24-502-01-01

12,5 cm / 5"

Universalgriff

Universal Handle

Mango universal

Manche universelle

Manico universale

24-502-05-01

24,5 cm

Tunnelierschaft

Tunneling Shaft

Vástago para tunelar

Tige pour tunneler

Gambo per tunnelare

gebogen

curved

curvo

courbée

curvo

24-502-06-01

24,5 cm

Tunnelierschaft

Tunneling Shaft

Vástago para tunelar

Tige pour tunneler

Gambo per tunnelare

gerade

straight

recto

droite

diritto

24-502-11-01

55,5 cm

Tunnelierschaft

Tunneling Shaft

Vástago para tunelar

Tige pour tunneler

Gambo per tunnelare

gebogen

curved

curvo

courbée

curvo

1/2



24-502-55-01

Ø 5 mm

Schraubolive

Screw Olive

Oliva

Oliva

Oliva

24-502-56-01

Ø 6 mm

Schraubolive

Screw Olive

Oliva

Oliva

Oliva

24-502-57-01

Ø 7 mm

Schraubolive

Screw Olive

Oliva

Oliva

Oliva

24-502-58-01

Ø 8 mm

Schraubolive

Screw Olive

Oliva

Oliva

Oliva

24-502-60-01

Ø 10 mm

Schraubolive

Screw Olive

Oliva

Oliva

Oliva

24-502-62-01

Ø 12 mm

Schraubolive

Screw Olive

Oliva

Oliva

Oliva

56-425-05-07

Halteplatte für Aufsätze

Plate for Tips

Soporte para cabezas

Supporto per punte

56-425-55-07

Metallbehälter

Metal Case

Caja metálica

Boîte métal

Contenitore metallico

55 x 11,5 x 3,5 cm

Fasziotomiemesser, Fasziotomiespatel

Fasciotomy Knife, Fasciotomy Spatulas
Cuchillo para fasciotomía, Espátulas para fasciotomía
Couteau pour fasciotomie, Spatule pour fasciotomie
Bisturi per fasciotomia, Spatole per fasciotomia

Herz- und Gefäßchirurgie

Cardio Thoracic and Vascular Surgery
Cirugía cardíaca, torácica y vascular
Chirurgie cardiaque, thoracique et vasculaire
Chirurgia cardiaca, toracica e vascolare

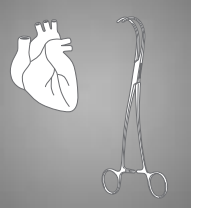

1/2

Hach
24-521-01-04
30 cm / 11 5/8"



1/2

Hach
24-526-25-07 -
24-526-52-07
30 cm / 11 5/8"

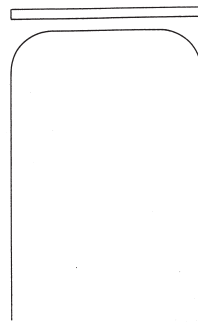

25 mm
24-526-25-07

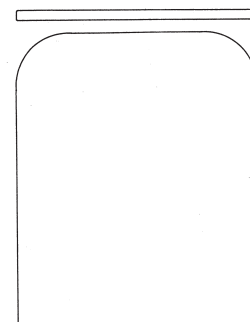

32 mm
24-526-32-07

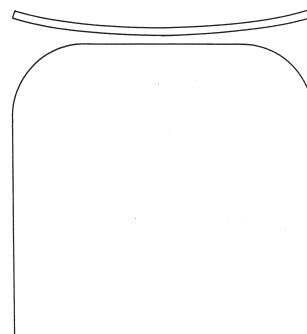

1/1

40 mm
24-526-40-07

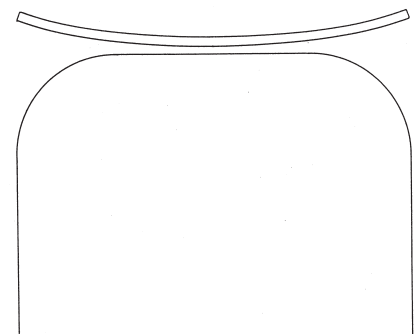

52 mm
24-526-52-07

Intimaspatel, Gefäßdissektoren

Intima Spatulas, Vascular Dissectors

Espátulas para la íntima, Disecadores vasculares

Spatules pour la tunique interne, Dissecteurs vasculaires

Spatole per intima, Dissettori vascolari

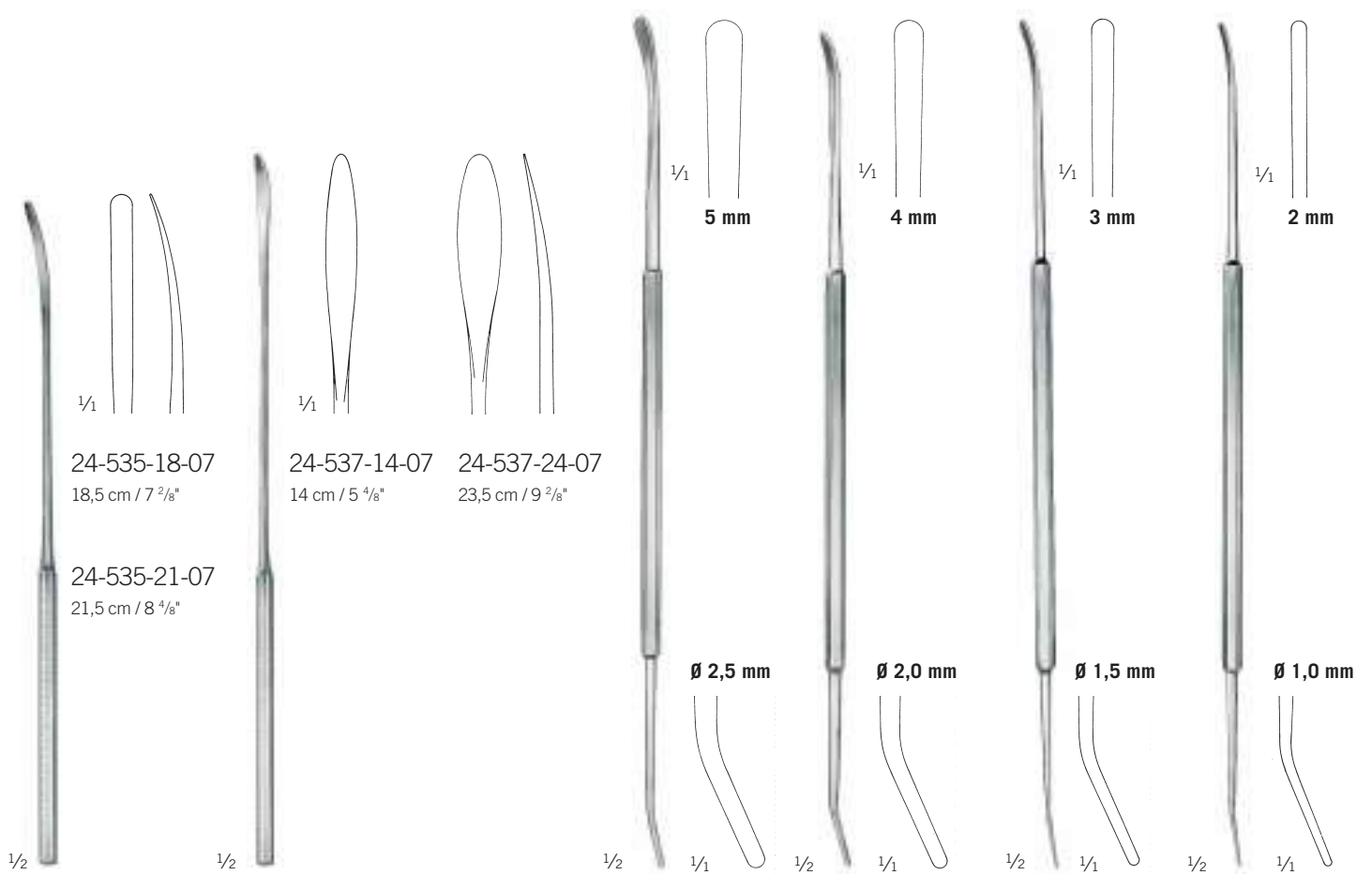

24-535-18-07 - 24-537-14-07 -
24-535-21-07 24-537-24-07

Robb
24-539-01-07
Fig. 1
24 cm / 9 4/8"

Robb
24-539-02-07
Fig. 2
24 cm / 9 4/8"

Robb
24-539-03-07
Fig. 3
24 cm / 9 4/8"

Robb
24-539-04-07
Fig. 4
24 cm / 9 4/8"

Nervhäkchen, Fadenfänger, Tourniquets

Nerve Hooklets, Tourniquets
 Ganchitos para nervios, Tourniquetes
 Crochets pour les nerfs, Tourniquets
 Uncini per nervi, Tornichetti

Herz- und Gefäßchirurgie

Cardio Thoracic and Vascular Surgery
 Cirugía cardíaca, torácica y vascular
 Chirurgie cardiaque, thoracique et vasculaire
 Chirurgia cardiaca, toracica e vascolare

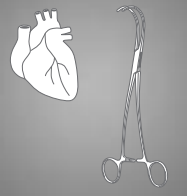

Crile
 24-541-20-07
 20 cm / 7 7/8"

Crile
 24-543-20-07
 20,5 cm / 8 1/8"

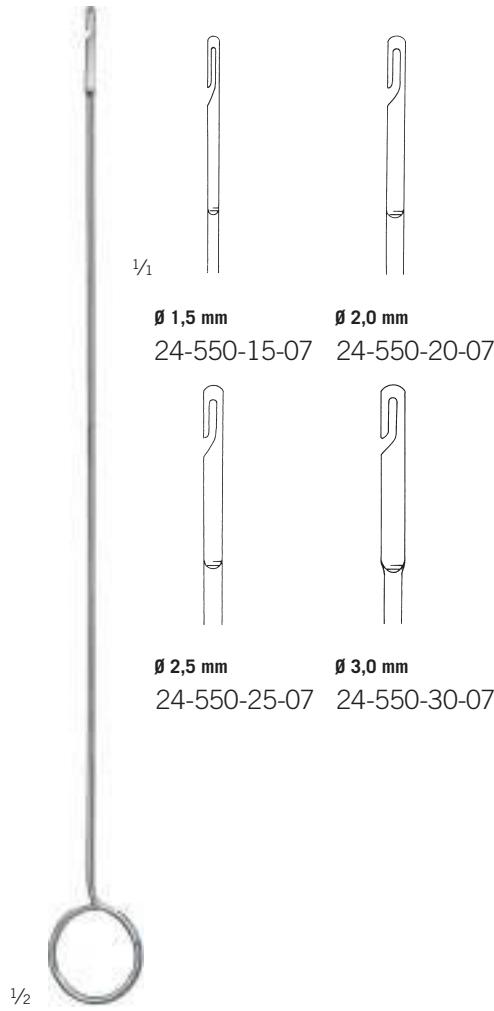

24-550-15-07 -
 24-550-30-07
 26 cm / 10 2/8"



Rumel-Belmont
 24-556-33-07 -
 24-558-33-07

Ø 4,2 mm
 24-556-33-07
 27 cm / 10 5/8"
 Ø 8,8 mm
 24-558-33-07
 30,5 cm / 12"

Kinder-Aortaklemmen, Kinder-Gefäßklemmen

Pediatric Aortic Clamps, Pediatric Vascular Clamps

Pinzas aórticas pediátricas, Pinzas vasculares pediátricas

Pinces-clamps pour aorte pédiatriques, Pinces vasculaires pédiatriques

Pinze per aorta pediatriche, Pinze vascolari pediatriche

Atrauma



Subramanian-Miniature
24-559-15-07

16 cm / 6 2/8"

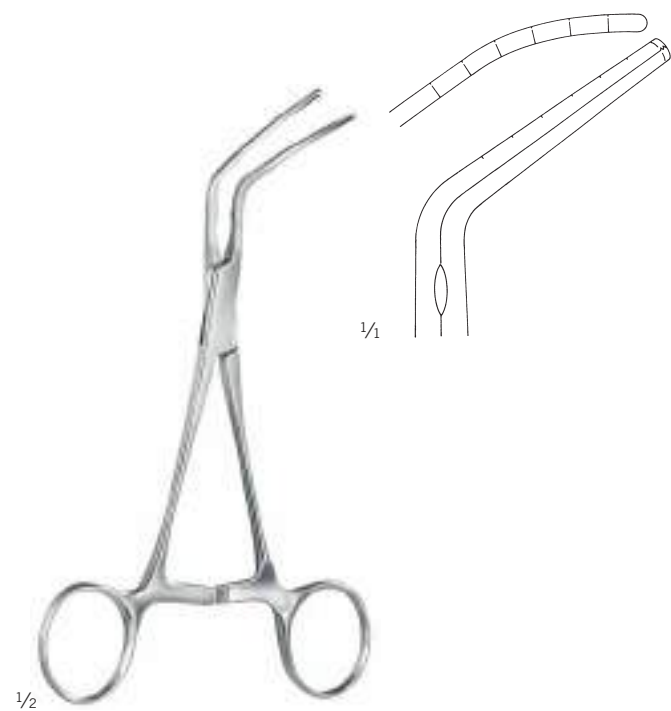

Subramanian
24-561-16-07

16 cm / 6 2/8"



Subramanian
24-563-16-07

16 cm / 6 2/8"

Kinder-Gefäßklemmen

Pediatric Vascular Clamps
 Pinzas vasculares pediátricas
 Pincas vasculaires pédiatriques
 Pinze vascolari pediatriche

Herz-, Thorax- und Gefäßchirurgie

Cardio Thoracic and Vascular Surgery
 Cirugía cardíaca, torácica y vascular
 Chirurgie cardiaque, thoracique et vasculaire
 Chirurgia cardiaca, toracica e vascolare

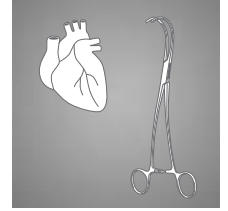

Atrauma

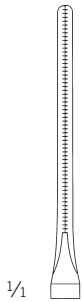

1/1

Fig. 1
 24-573-01-07
 14 cm / 5 4/8"

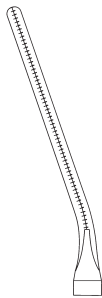

Fig. 2
 24-573-02-07
 14 cm / 5 4/8"

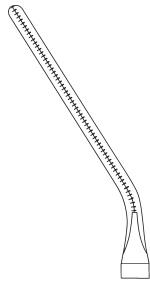

Fig. 3
 24-573-03-07
 14 cm / 5 4/8"

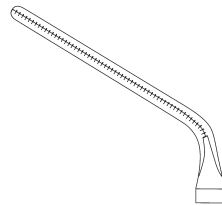

Fig. 4
 24-573-04-07
 14 cm / 5 4/8"

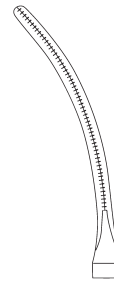

Fig. 5
 24-573-05-07
 14 cm / 5 4/8"

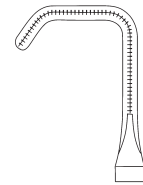
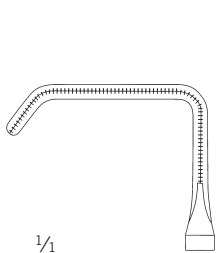

Fig. 6
 24-573-06-07
 13 cm / 5"



1/1

Fig. 7
 24-573-07-07
 13 cm / 5"

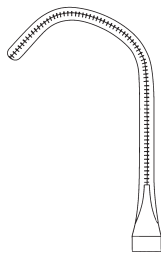

Fig. 8
 24-573-08-07
 14 cm / 5 4/8"

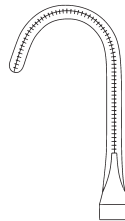

Fig. 9
 24-573-09-07
 13 cm / 5"

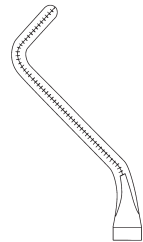

Fig. 10
 24-573-10-07
 14 cm / 5 4/8"

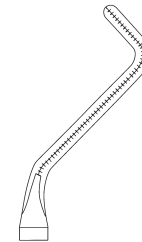

Fig. 11
 24-573-11-07
 14 cm / 5 4/8"

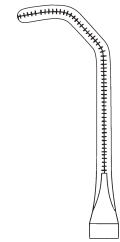
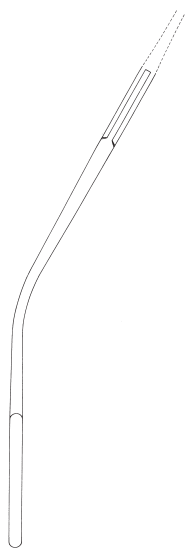

Fig. 12
 24-573-12-07
 14 cm / 5 4/8"



1/2

De Bakey baby
 24-573-01-07 -
 24-573-15-07



1/1

Fig. 13
 24-573-13-07
 14 cm / 5 4/8"

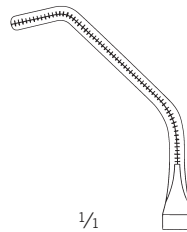

Fig. 14
 24-573-14-07
 14 cm / 5 4/8"



Fig. 15
 24-573-15-07
 14 cm / 5 4/8"

Kinder-Gefäßklemmen

Pediatric Vascular Clamps
 Pinzas vasculares pediátricas
 Pincas vasculaires pédiatriques
 Pinze vascolari pediatriche

Atrauma

finoLine



1/2



1/1

24-580-01-07
 24-580-01-09
 13,5 cm / 5 3/8"

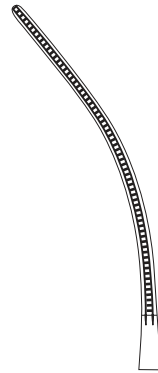

24-580-02-07
 24-580-02-09
 13 cm / 5 1/8"

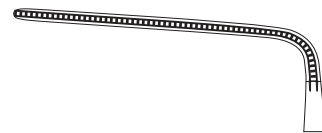

24-580-03-07
 24-580-03-09
 10,5 cm / 4 1/8"

De Bakey
 24-580-01-07 -
 24-580-03-09

feine Zahnung
 delicate serration
 dentado fina
 denture fine
 dentatura delicata

1/2

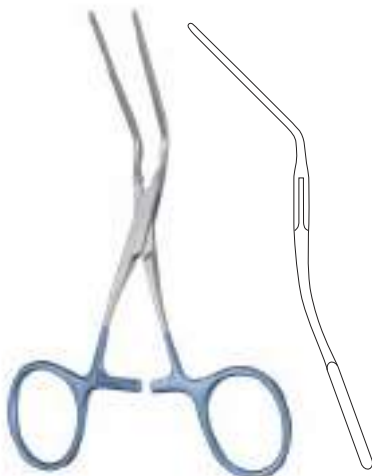

1/1

24-580-04-07
 24-580-04-09
 12 cm / 4 6/8"

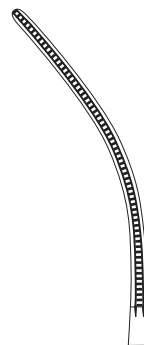

24-580-05-07
 24-580-05-09
 13 cm / 5 1/8"

De Bakey
 24-580-04-07 -
 24-580-05-09

feine Zahnung
 delicate serration
 dentado fina
 denture fine
 dentatura delicata

Neonatal-Gefäßklemmen

Neonatal Vascular Clamps

Pinzas vasculares para recién nacidos

Pinces vasculaires pour nouveaux nés

Pinze vascolari per neonati

Herz-, Thorax- und Gefäßchirurgie

Cardio Thoracic and Vascular Surgery

Cirugía cardíaca, torácica y vascular

Chirurgie cardiaque, thoracique et vasculaire

Chirurgia cardiaca, toracica e vascolare

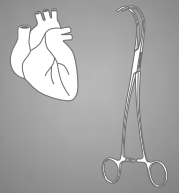

Atrauma

finoLine



De Bakey
24-581-01-09

10,5 cm / 4 1/8"

sehr feine Zahnung
very delicate serration
dentado muy fina
denture très fine
dentatura molto delicata



De Bakey
24-581-02-09 -
24-581-03-09

10,5 cm / 4 1/8"

sehr feine Zahnung
very delicate serration
dentado muy fina
denture très fine
dentatura molto delicata



De Bakey
24-581-04-09 -
24-581-05-09

10,5 cm / 4 1/8"

sehr feine Zahnung
very delicate serration
dentado muy fina
denture très fine
dentatura molto delicata

Kinder-Gefäßklemmen

Pediatric Vascular Clamps

Pinzas vasculares pediátricas

Pinces vasculaires pédiatriques

Pinze vascolari pediatriche

Atrauma

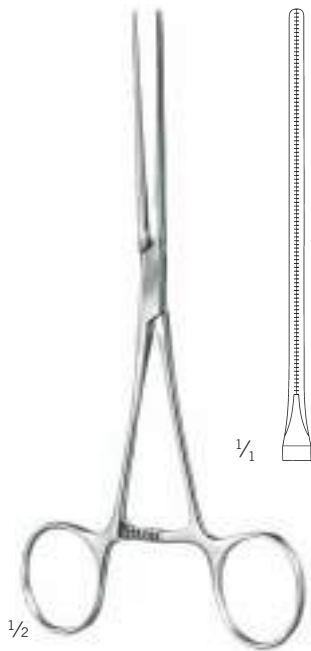

De Bakey baby
24-588-16-07
16,5 cm / 6 4/8"

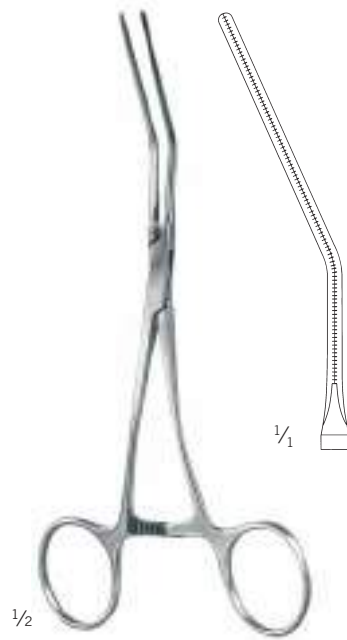

De Bakey baby
24-589-16-07
16,5 cm / 6 4/8"

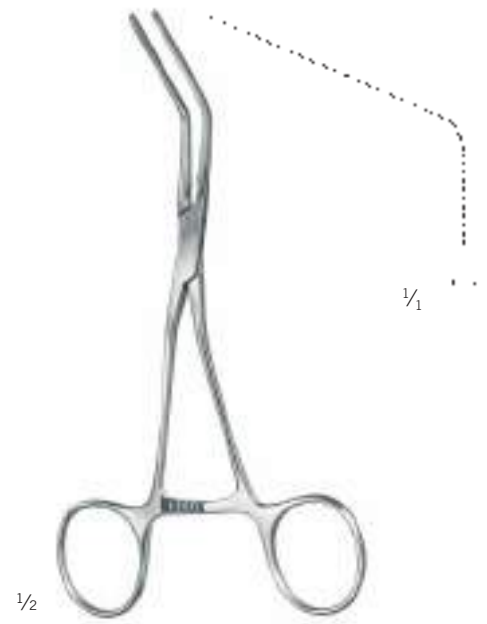

De Bakey baby
24-590-16-07
15,5 cm / 6"

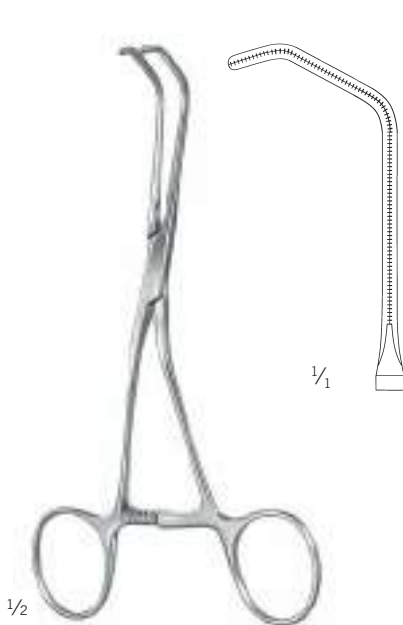

De Bakey baby
24-591-15-07
15,5 cm / 6"

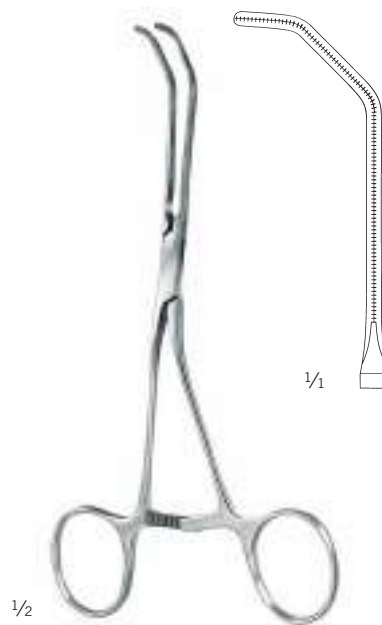

De Bakey baby
24-592-16-07
16 cm / 6 2/8"

Kinder-Gefäßklemmen

Pediatric Vascular Clamps
 Pinzas vasculares pediátricas
 Pincas vasculaires pédiatriques
 Pinze vascolari pediatriche

Herz-, Thorax- und Gefäßchirurgie

Cardio Thoracic and Vascular Surgery
 Cirugía cardíaca, torácica y vascular
 Chirurgie cardiaque, thoracique et vasculaire
 Chirurgia cardiaca, toracica e vascolare

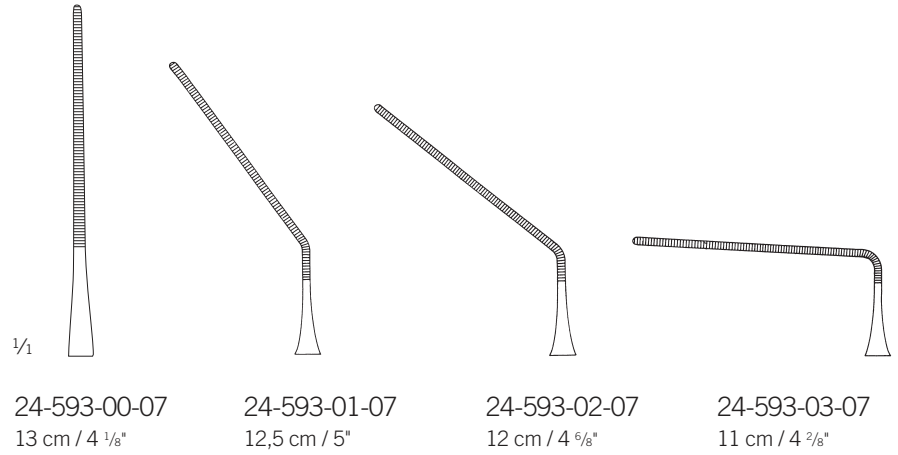
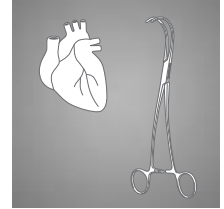

Castañeda
 24-593-00-07 -
 24-597-12-07

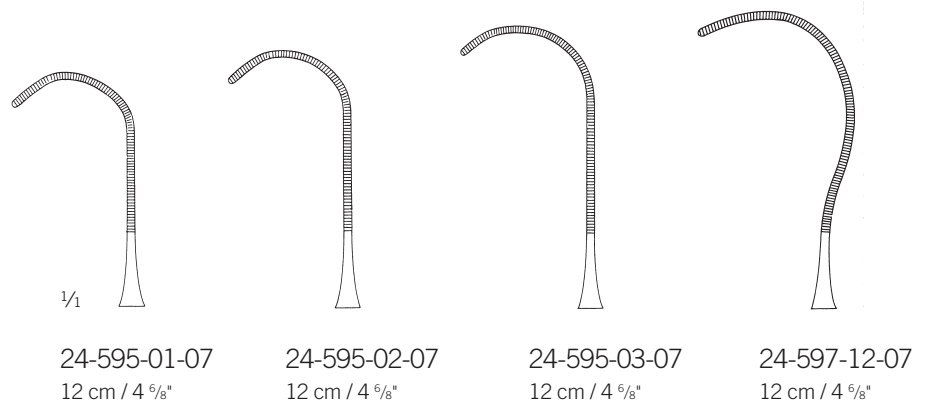

Neurochirurgie
Neurosurgery
Neurocirurgia
Neurochirurgie
Neurochirurgia

24

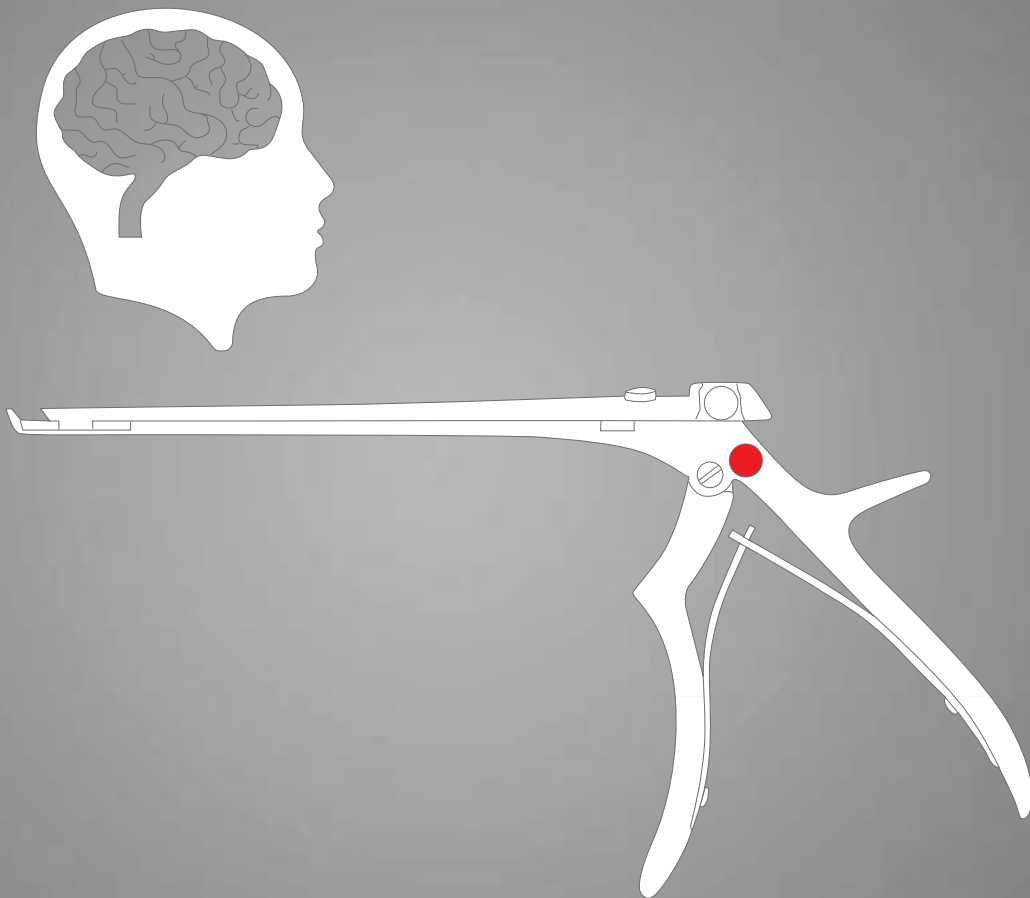

Spezial-Produkte

Special Products

Productos especiales

Produits spéciaux

Prodotti speciali

Unser Ordner-System „Neurosurgery“ enthält die gesamte Palette der KLS-Martin-Neuro-Instrumente.

Our folder system “Neurosurgery” contains the full range of KLS-Martin neurosurgical instruments.

Nuestro sistema de carpetas “Neurosurgery” incluye la gama completa de instrumentos de KLS-Martin para neurocirugía.

Notre système de dossiers «Neurosurgery» contient l'ensemble de la palette des instruments de neurochirurgie KLS Martin.

Il nostro sistema di cartelle “Neurosurgery” contiene tutti gli strumenti per la neurochirurgia di KLS Martin.

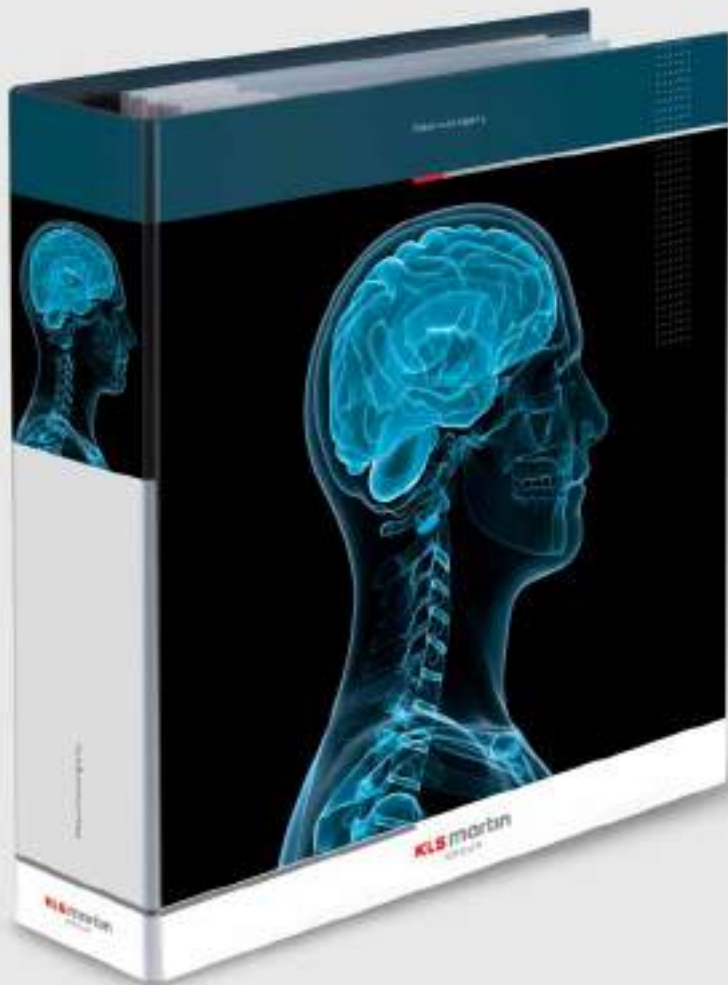
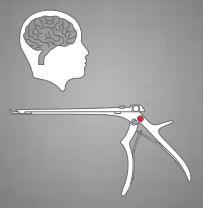

Drahtsägen

Wire Saws
Sierras de hilo
Fils-scies
Fili sega

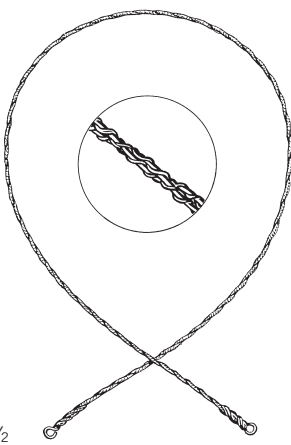

24-600-30-07
30 cm / 11 5/8"

24-600-40-07
40 cm / 15 5/8"

24-600-50-07
50 cm / 19 5/8"

24-600-60-07
60 cm / 23 5/8"

24-600-70-07
70 cm / 27 4/8"

Gigli
24-600-30-07 -
24-600-70-07



Gigli
24-602-01-01

Drahtsägen-Handgriff
Wire saw handle
Mango de gancho
Manche à crochet
Manico con uncino



De Martel
24-618-33-07

33 cm / 13"
Einführinstrument
Wire saw guide
Conductor para sierras de hilo
Conducteur pour fils-scies
Introduttore

Schädelhalter

Skull Traction Tongs
Estribos de tracción craneal
Pincas de traction crânienne
Pinze per trazione craniale

Neurochirurgie

Neurosurgery
Neurocirurgia
Neurochirurgie
Neurochirurgia

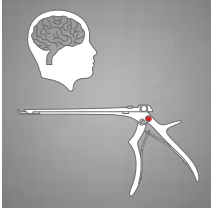

1/2

Crutchfield
24-641-01-07

kleines Modell
small pattern
modelo pequeño
modèle petit
modello piccolo



1/2

Crutchfield
24-641-02-07

mittleres Modell
medium pattern
modelo mediano
modèle moyen
modello medio



1/2

Ø 3,5 mm
24-641-04-07

7 cm / 2 5/8"
Vorböhrer
Drill Point
Perforador
Alésoir
Alesatore

Ø 5 mm
24-641-05-07

7 cm / 2 5/8"
Vorböhrer
Drill Point
Perforador
Alésoir
Alesatore



24-641-02-07

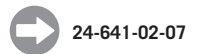

24-641-02-07



1/2

24-643-01-07

großes Modell
large pattern
modelo grande
modèle grand
modello grande

24-643-10-07

Ersatzdorn
Spare Pin
Espina de repuesto
Pointe de rechange
Punta di ricambio

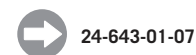

24-643-01-07

Schädelzangen

Cranial Rongeurs

Pinzas sacabocados craneales

Pinces emporte-pièces crâniennes

Pinze per craniectomia



Dahlgren
24-654-20-07

19,5 cm / 7 5/8"

mit 3 Haken
with 3 hooks
con 3 ganchos
avec 3 crochets
con 3 ganci



De Vilbiss
24-658-21-07

21 cm / 8 2/8"

mit 2 Haken
with 2 hooks
con 2 ganchos
avec 2 crochets
con 2 ganci



Cone
24-659-22-07

22,5 cm / 8 7/8"

Schädelstanze
Cranial Punch
Pinza sacabocado craneal
Pince emporte-pièces crânienne
Pinza per craniectomia

Clips und Anlegezangen

Clips and Applying Forceps
 Grapas y pinzas aplicadoras
 Clips et pincers pour appliquer
 Agrafes e pinze per applicare

Neurochirurgie

Neurosurgery
 Neurocirurgia
 Neurochirurgie
 Neurochirurgia

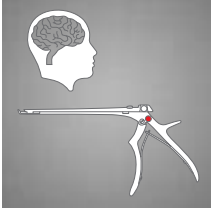

Olivecrona-Toennis
 24-661-14-07

Klammerzange
 Clip Applying Forceps
 Pinza para colocar grapas
 Pince pour poser les agrafes en argent
 Pinza per applicare le agrafe di argento



McKenzie
 24-663-19-07

18,5 cm / 7 2/8"
 Klammerzange
 Clip Applying Forceps
 Pinza clipadora
 Pince pour poser les agrafes
 Pinza per applicare le agrafe



Kölner
 24-674-00-07

Kopfhautklammer
 Scalp Clip
 Grapa para cuero cabelludo
 Agrafes pour cuir chevelu
 Pinze per il cuoio capelluto
 VE = 50 Stück
 SU = 50/pack
 UV = 50 piezas
 UC = 50 unités
 UV = 50 pezzi



Raney
 24-675-00-07

Kopfhautklammer
 Scalp Clip
 Grapa para cuero cabelludo
 Agrafes pour cuir chevelu
 Pinze per il cuoio capelluto



Raney
 24-676-00-07

15,5 cm / 6"
 Anlege- und Abnehmzange
 Applying/Removal Forceps
 Pinza para aplicar y quitar agrafes
 Pince pour appliquer et enlever les
 clips hémostatiques du cuir
 Pinza per applicare e togliere le agrafe
 emostatiche al cuoio capelluto

➔ 24-675-00-07

Dissektoren

Dissectors
Disecadores
Dissecteurs
Dissettori



Yasargil
24-678-01-07 -
24-678-02-07

Galeahaken
Galea hook
Gancho Galea
Ecarteur Galea
Divaricatore Galea



Toennis
24-680-25-07
24 cm / 9 4/8"

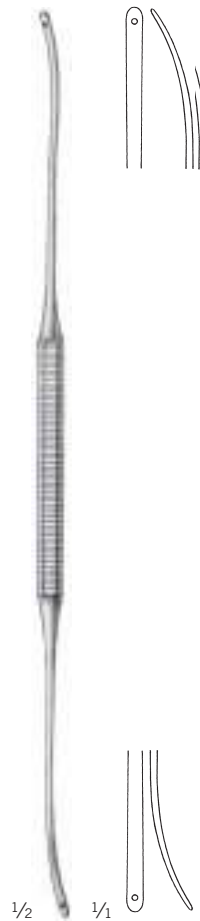

Olivecrona
24-681-24-07
24 cm / 9 4/8"

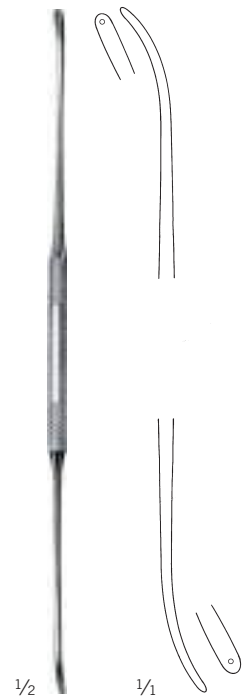

Olivecrona
24-682-18-07
18 cm / 7 1/8"

Dissektoren

Dissectors
Disecadores
Dissecteurs
Dissettori

Neurochirurgie

Neurosurgery
Neurocirurgia
Neurochirurgie
Neurochirurgia

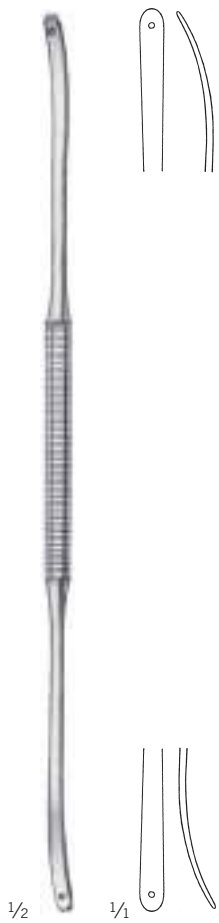
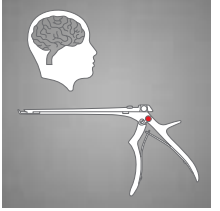

Olivecrona
24-683-24-07
24 cm / 9 $\frac{4}{8}$ "

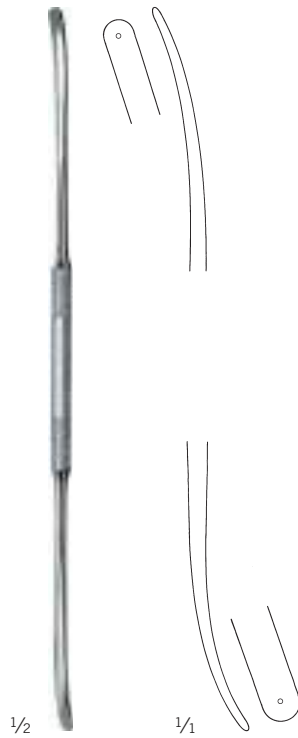

Olivecrona
24-684-19-07
20 cm / 7 $\frac{7}{8}$ "



Sachs
24-685-21-07
20,5 cm / 8 $\frac{1}{8}$ "

Dissektoren

Dissectors
Disecadores
Dissecteurs
Dissettori



Milligan
24-686-21-07
22 cm / 8 5/8"



Davis
24-687-21-07
21,5 cm / 8 4/8"



24-688-22-07
22 cm / 8 5/8"



Davis
24-691-24-07
24,5 cm / 9 5/8"

Dissektoren

Dissectors
Disecadores
Dissecteurs
Dissettori

Neurochirurgie

Neurosurgery
Neurocirurgia
Neurochirurgie
Neurochirurgia

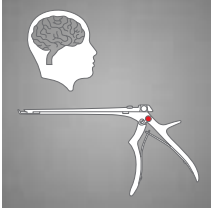

Penfield
24-690-01-07 -
24-690-05-07

Retraktoren zur Fixation am Schädel

Self-Retaining Retractors, for Skull Mounting

Separadores para la fijación del cráneo

Ecarteurs autofixant au crâne

Autofissatore per retrattori, per il supporto del cranio



Leyla 24-702-01-07	Selbsthaltender Hirnspatel mit 1 Spannarm, komplett, bestehend aus:	Self-retaining brain retractor with 1 flexible arm, complete, consisting of:	Separador automático para el cerebro con 1 brazo, completo, compuesto de:	Ecarteur autofixant au crâne avec 1 bras complet, composé de:	Autofissatore per retrattore cervicale con 1 braccio, completo, composto da:
24-702-03-07	1 Spannarm, flexibel	Flexible arm	Brazo, flexible	Bras flexible	Braccio flessibile
24-702-04-07	1 Fixiervorrichtung für 1 Spannarm	Fixation base for 1 arm	Fijador para 1 brazo	Base de fixation pour 1 bras	Base di fissaggio per 1 braccio
24-702-08-07	1 Spatelhalter für flache Spatel	Support for flat brain spatulas	Porta-espátula para espátulas planas	Support pour spatules plats	Supporto per spatole cervicali piatte

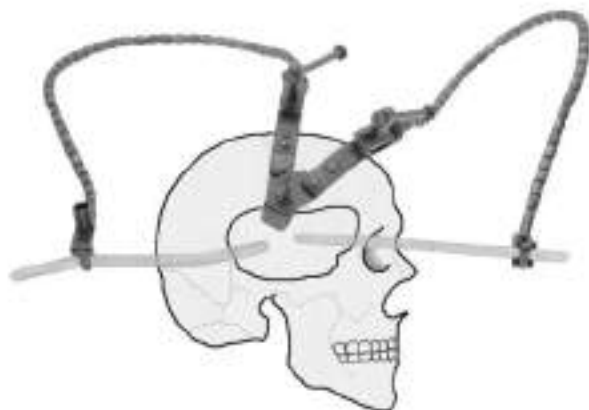

Leyla 24-702-02-07	Selbsthaltender Hirnspatel mit 2 Spannarmen, komplett, bestehend aus:	Self-retaining brain retractor with 2 arms, complete, consisting of:	Separador automático para el cerebro con 2 brazos, completo, compuesto de:	Ecarteur autofixant au crâne avec 2 bras complet, composé de:	Autofissatore per retrattore cervicale con 2 bracci, completo, composto da:
24-702-03-07	2 Spannarme, flexibel	Flexible arms	Brazos, flexibles	Bras, flexibles	Bracci, flessibili
24-702-05-07	1 Fixiervorrichtung für 2 Spannarme	Fixation base for 2 arms	Fijador para 2 brazos	Base de fixation pour 2 bras	Base di fissaggio per 2 bracci
24-702-08-07	2 Spatelhalter für flache Spatel	Supports for flat brain spatulas	Porta-espátulas para espátulas planas	Supports pour spatules plats	Supporti per spatole cervicali piatte

Zubehör zu Leyla-Retraktoren

Accessories for Leyla Self Retaining Retractors
Accesorios para separadores automáticos de Leyla
Accessoires pour écarteurs autofixants de Leyla
Accessori per autofissatori per retrattori di Leyla

Neurochirurgie

Neurosurgery
Neurocirugía
Neurochirurgie
Neurochirurgia

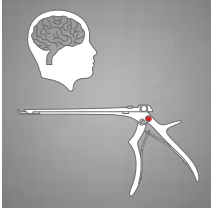

Leyla
24-702-03-07

Spannarm zum Aufstecken auf Kupplungsköpfe 24-702-15-07 / 24-702-16-07 und Fixiervorrichtungen 24-702-04-07 / 24-702-05-07 / 24-702-06-07

Flexible arm for attaching coupling heads 24-702-15-07 / 24-702-16-07 and fixation bases 24-702-04-07 / 24-702-05-07 / 24-702-06-07

Brazo para colocar sobre el acoplamiento 24-702-15-07 / 24-702-16-07 y los fijadores 24-702-04-07 / 24-702-05-07 / 24-702-06-07

Bras flexible pour fixation aux têtes d'accouplement 24-702-15-07 / 24-702-16-07 et base de fixation 24-702-04-07 / 24-702-05-07 / 24-702-06-07

Braccio flessibile per il fissaggio delle teste di accoppiamento 24-702-15-07 / 24-702-16-07 e le basi di fissaggio 24-702-04-07 / 24-702-05-07 / 24-702-06-07



Leyla
24-702-04-07

Fixiervorrichtung für 1 Spannarm 24-702-03-07, zum Festschrauben am Schädel

Fixation base for 1 flexible arm 24-702-03-07, for skull mounting

Fijador para 1 brazo 24-702-03-07, para atornillar al cráneo

Base de fixation pour 1 bras 24-702-03-07, pour fixer au crâne

Base di fissaggio per 1 braccio flessibile 24-702-03-07, per il supporto del cranio



Leyla
24-702-05-07

Fixiervorrichtung für 2 Spannarme 24-702-03-07, zum Festschrauben am Schädel

Fixation base for 2 flexible arms 24-702-03-07, for skull mounting

Fijador para 2 brazos 24-702-03-07, para atornillar al cráneo

Base de fixation pour 2 bras 24-702-03-07, pour fixer au crâne

Base di fissaggio per 2 bracci flessibili 24-702-03-07, per il supporto del cranio



Leyla
24-702-06-07

Fixiervorrichtung für 1 Spannarm 24-702-03-07, zum Festschrauben an Rohrteilen bis Ø 16 mm

Fixation base for 1 flexible arm 24-702-03-07, for mounting to bars up to Ø 16 mm

Fijador para 1 brazo 24-702-03-07, para atornillar a tubos hasta Ø 16 mm

Base de fixation pour 1 bras 24-702-03-07, pour fixer aux tubes jusqu'à Ø 16 mm

Base di fissaggio per 1 braccio flessibile 24-702-03-07, per il supporto di asta di raccordo da Ø 16 mm



Leyla
24-702-07-07

Spatelhalter mit Rundschaft bis Ø 5,5 mm, zur Befestigung am Spannarm 24-702-03-07

Support for brain spatulas with round shaft up to Ø 5.5 mm, fixation to flexible arm 24-702-03-07

Porta-espátula con vástago redondo hasta Ø 5,5 mm, para sujetarlo al brazo 24-702-03-07

Support pour spatules avec tiges ronds jusqu'à Ø 5,5 mm, pour fixation au bras 24-702-03-07

Supporto per spatole craniali con diametro asse Ø 5,5 mm, fissato al braccio flessibile 24-702-03-07



Leyla
24-702-08-07

Spatelhalter für flache Spatel, zur Befestigung am Spannarm 24-702-03-07

Support for flat brain spatulas, fixation to flexible arm 24-702-03-07

Porta-espátula para espátulas planas, para sujetarlo al brazo 24-702-03-07

Support pour tiges plats, pour fixation au bras 24-702-03-07

Supporto per spatole cervicali piate, fissato al braccio flessibile 24-702-03-07

Retraktoren zur Fixation am OP-Tisch

Self-Retaining Retractors, Fixation to Operating Table

Separadores para la fijación a la mesa de operaciones

Ecarteurs pour fixation à la table d'opération

Autofissatori per retrattori, da fissare alla tavola operatoria



Leyla 24-702-11-07	Selbsthaltender Hirnspatel mit 1 Spannarm, komplett, bestehend aus:	Self-retaining brain retractor with 1 flexible arm, complete, consisting of:	Separador automático para el cerebro con 1 brazo, completo, compuesto de:	Ecarteur du cerveau auto-fixant avec 1 bras complet, composé de:	Autofissatore per retrattori cervicali con 1 braccio flessibile, composto da:
24-702-13-07	1 Kugelgelenkkloben	Ball and socket joint	Articulación esférica	Articulation sphérique	Giunto a sfera ad incastro
24-702-14-07	1 Haltearm	Holding rod	Brazo de apoyo	Bras de fixation	Porta-asta
24-702-15-07	1 Kupplungskopf	Coupling head	Acoplamiento	Tête d'accouplement	Testa accoppiamento
24-702-03-07	1 Spannarm	Flexible arm	Brazo	Bras flexible	Braccio flessibile
24-702-07-07	1 Spatelhalterung für Spatel mit rundem Griff	Support, for brain spatulas with round shaft	Porta-espátula para espátulas con mangos redondos	Support pour spatules avec manches ronds	Supporto per spatole craniali con albero rotondo



Leyla 24-702-12-07	Selbsthaltender Hirnspatel mit 2 Spannarmen, komplett, bestehend aus:	Self-retaining brain retractor with 2 flexible arms, complete, consisting of:	Separador automático para el cerebro con 2 brazos, completo, compuesto de:	Ecarteur du cerveau auto-fixant avec 2 bras complet, composé de:	Autofissatore per retrattori cervicali con 2 bracci flessibili, composto da:
24-702-13-07	1 Kugelgelenkkloben	Ball and socket joint	Articulación esférica	Articulation sphérique	Giunto a sfera ad incastro
24-702-14-07	1 Haltearm	Holding rod	Brazo de apoyo	Bras de fixation	Porta-asta
24-702-16-07	2 Kupplungsköpfe	Coupling heads	Acoplamientos	Têtes d'accouplement	Teste accoppiamento
24-702-03-07	2 Spannarme	Flexible arms	Brazos	Bras flexibles	Bracci flessibili
24-702-08-07	1 Spatelhalterung, für flache Spatel	Support, for flat brain spatulas	Porta-espátula, para espátulas planas	Support pour spatules plats	Supporto per spatole craniali piatte
24-702-07-07	1 Spatelhalterung, für Spatel mit rundem Griff	Support, for brain spatulas with round shaft	Porta-espátula para espátulas con mangos redondos	Support pour spatules avec manches ronds	Supporto per spatole craniali con albero rotondo

Zubehör zu Leyla-Retraktoren

Accessories for Leyla Retractors

Accesorios para separadores automáticos de for Leyla

Accessoires pour écarteurs Leyla

Accessori per autofissatori per retrattori di Leyla

Neurochirurgie

Neurosurgery

Neurocirurgia

Neurochirurgie

Neurochirurgia

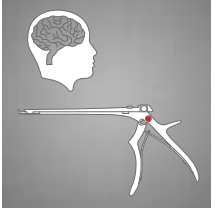

Leyla 24-702-13-07

Kugelgelenkkloben, zur Befestigung des Haltearms 24-702-14-07 an OP-Tisch-Schienen

Ball and socket joint, for fixation of holding rod 24-702-14-07 to pole of operating table

Articulación esférica, para sujetar el brazo de apoyo 24-702-14-07 sobre la mesa de operaciones

Articulation sphérique pour fixation du bras 24-702-14-07 aux bandes de la table d'opération

Giunto a sfera ad incastro, per il fissaggio dell'asta 24-702-14-07 all'estremità del tavolo operatorio



Leyla 24-702-14-07

Haltearm zur Fixation im Kugelgelenkkloben 24-702-13-07 und zur Aufnahme der Kupplungsköpfe 24-702-15-07 / 24-702-16-07

Holding rod for fixation in ball and socket joint 24-702-13-07 and to take coupling heads 24-702-15-07 / 24-702-16-07

Brazo de apoyo para fijar en la articulación esférica 24-702-13-07 y para recoger los acoplamientos 24-702-15-07 / 24-702-16-07

Bras d'appui pour fixer dans l'articulation sphérique 24-702-13-07 pour prendre les têtes d'accouplement 24-702-15-07 / 24-702-16-07

Porta asta per il fissaggio al giunto a sfera 24-702-13-07 e per prendere le teste di accoppiamento 24-702-15-07 / 24-702-16-07



Leyla 24-702-15-07

Kupplungskopf zur Aufnahme von 1-5 Spannarmen 24-702-03-07

Coupling head to take 1-5 flexible arms 24-702-03-07

Acoplamiento para sujetar 1-5 brazos 24-702-03-07

Tête d'accouplement pour prendre 1-5 bras flexibles 24-702-03-07

Testa accoppiamento per prendere 1-5 bracci flessibili 24-702-03-07



Leyla 24-702-16-07

Kupplungskopf, drehbar, in allen Ebenen fixierbar, zur Aufnahme von 1 Spannarm 24-702-03-07

Coupling head, turnable, can be fixed in any position, to take 1 flexible arm 24-702-03-07

Acoplamiento, girable y se puede fijar en todas las posturas para sujetar un brazo 24-702-03-07

Tête d'accouplement, rotative, peut être fixée en toute position, pour tenir 1 bras flexible 24-702-03-07

Testa accoppiamento, girevole, può essere fissata in qualsiasi posizione, supporta 1 braccio flessibile 24-702-03-07

Spatel

Spatulas
Espátulas
Spatules
Spatole



24-720-08-01	155 x 8 mm
24-720-11-01	155 x 11 mm
24-720-14-01	155 x 14 mm
24-720-17-01	155 x 17 mm

Heifetz
24-720-08-01 -
24-720-17-01

biegsam
malleable
maleable
malléable
malleabile



24-721-14-01	200 x 14 mm
24-721-17-01	200 x 17 mm
24-721-20-01	200 x 20 mm

Heifetz
24-721-14-01 -
24-721-20-01

biegsam
malleable
maleable
malléable
malleabile

Haken

Hooks
Ganchos
Crochets
Uncini

Neurochirurgie

Neurosurgery
Neurocirurgia
Neurochirurgie
Neurochirurgia

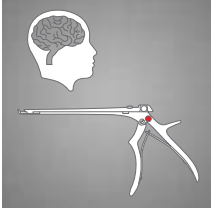

Groningen
24-738-26-07
26,5 cm / 10 ³/₈"



Groningen
24-740-26-07
26,5 cm / 10 ³/₈"

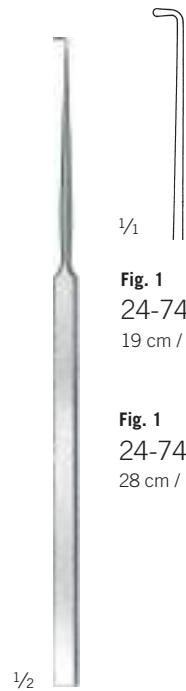

Fig. 1
24-742-19-07
19 cm / 7 ⁴/₈"

Fig. 1
24-742-28-07
28 cm / 11"



Fig. 2
24-744-19-07
19 cm / 7 ⁴/₈"

Fig. 2
24-744-28-07
28 cm / 11"

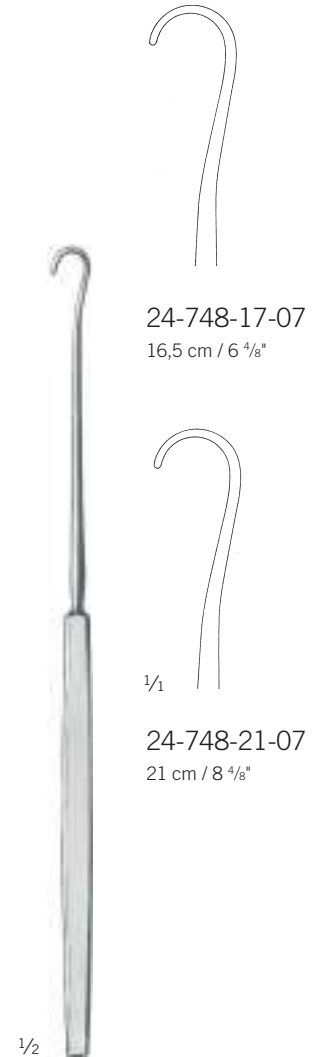

24-748-17-07
16,5 cm / 6 ⁴/₈"

24-748-21-07
21 cm / 8 ⁴/₈"

Haken

Hooks
Ganchos
Crochets
Uncini

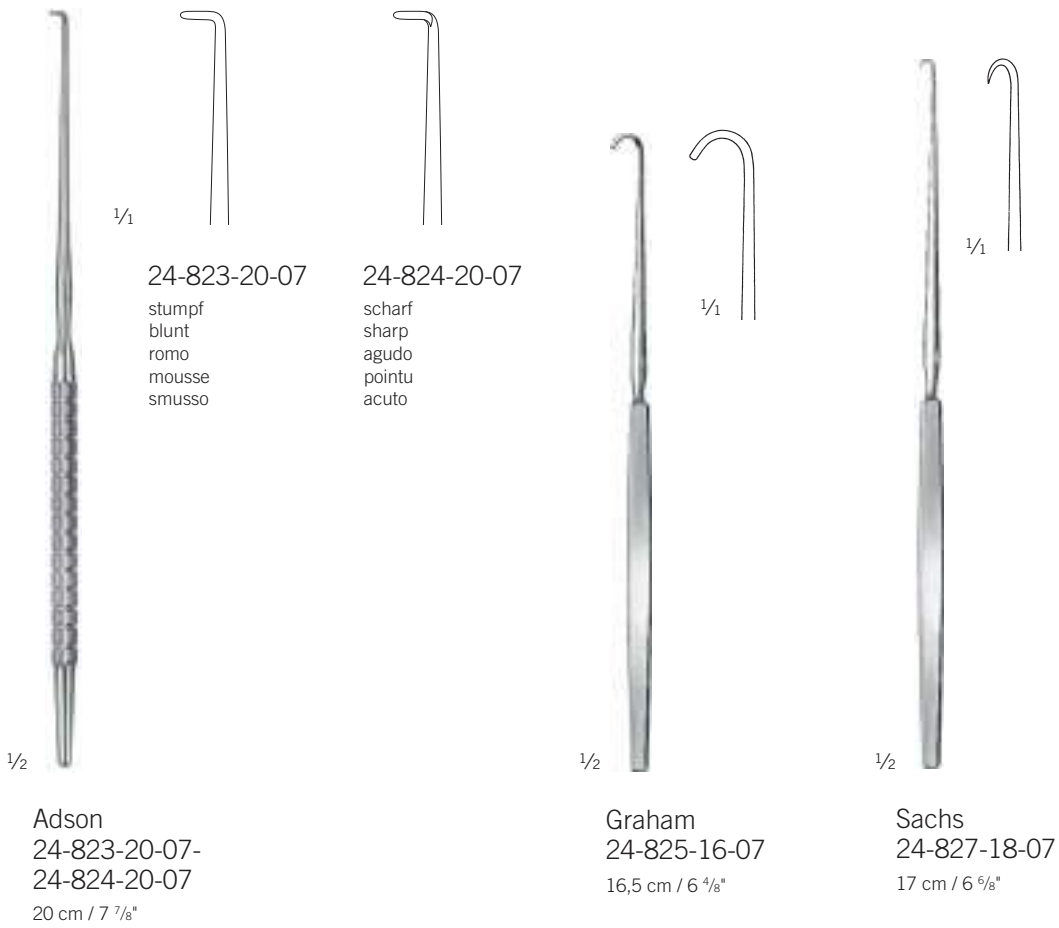

Haken

Hooks
Ganchos
Crochets
Uncini

Neurochirurgie

Neurosurgery
Neurocirurgia
Neurochirurgie
Neurochirurgia

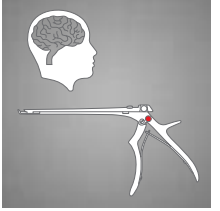

24-830-19-07 -
24-831-19-07
19 cm / 7 4/8"
Mikro-Häkchen
Micro hooklet
Micro-gancho
Micro-crochet
Micro-uncino

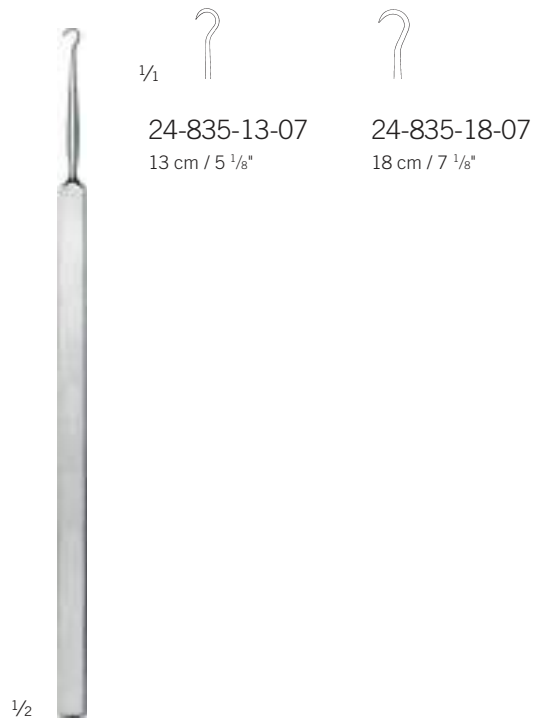

Frazier
24-835-13-07 -
24-835-18-07

Mikro-Scheren

Micro Scissors

Micro-Tijeras

Micro-Ciseaux

Micro-Forbici



1/2

Vannas
24-850-01-07 -
24-850-03-07
12 cm / 4 5/8"

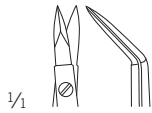

1/4

24-850-01-07

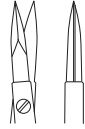

24-850-02-07

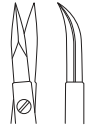

24-850-03-07

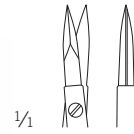

1/4

24-850-04-07

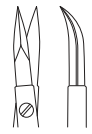

24-850-05-07



1/2

Vannas
24-850-04-07 -
24-850-05-07
16 cm / 6 2/8"



1/2

Millesi
24-850-10-07 -
24-850-11-07
16 cm / 6 2/8"

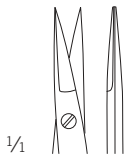

1/4

24-850-10-07



24-850-11-07



1/2

Jacobson
24-850-15-07
18,5 cm / 7 2/8"

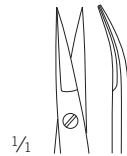

1/4

Mikro-Scheren

Micro Scissors
Micro-Tijeras
Micro-Ciseaux
Micro-Forbici

Neurochirurgie

Neurosurgery
Neurocirurgia
Neurochirurgie
Neurochirurgia

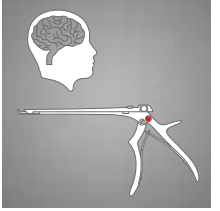

1/2

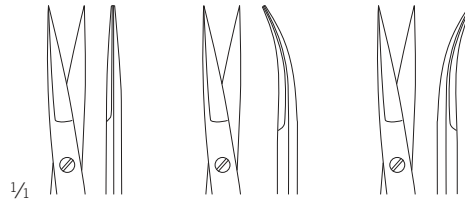



	15 mm	15 mm	15 mm
16,5 cm / 6 5/8"	24-850-20-07	24-850-21-07	
20 cm / 7 7/8"	24-850-22-07	24-850-23-07	24-850-24-07

Yasargil
24-850-20-07 -
24-850-24-07

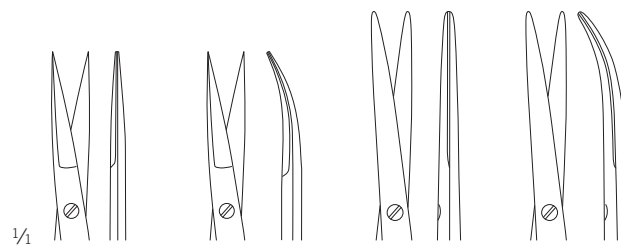

1/2



	A	A	D	D
	15 mm	15 mm		
20 cm / 7 7/8"			24-850-30-07	24-850-31-07
22,5 cm / 8 7/8"	24-850-25-07	24-850-26-07	24-850-33-07	24-850-32-07
24,5 cm / 9 5/8"		24-850-28-07		

Yasargil
24-850-25-07 -
24-850-33-07

Mikro-Scheren

Micro Scissors

Micro-Tijeras

Micro-Ciseaux

Micro-Forbici



1/2

Nagel
24-850-40-07 -
24-850-42-07
20 cm / 7 7/8"

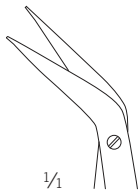

1/1

24-850-40-07

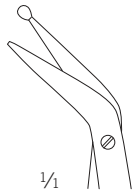

1/1

24-850-41-07

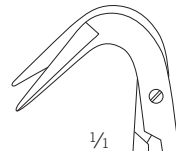

1/1

24-850-42-07

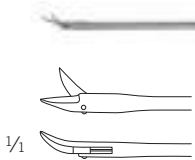

1/1



1/2

Fahlbusch
24-850-50-07
16,5 cm / 6 4/8"

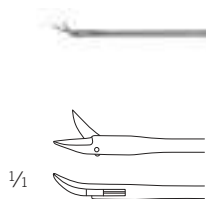

1/1



1/2

Caspar
24-850-60-07
11,5 cm / 4 4/8"

Mikro-Pinzetten

Micro Forceps
Micro-Pinzas
Micro-Pinces
Micro-Pinze

Neurochirurgie

Neurosurgery
Neurocirurgia
Neurochirurgie
Neurochirurgia

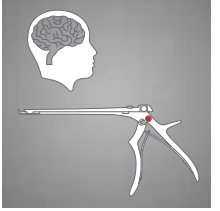

 1/2	 1/1	 1/2	 1/1	 1/2	 1/1	 1/1	 1/1	 1/1
Jacobson 24-851-01-07 18 cm / 7 1/8" ohne Sperre w/o ratchet sin trinquete sans cran d'arrêt senza arresto		Jacobson 24-851-02-07 18 cm / 7 1/8" mit Sperre with ratchet con trinquete avec cran d'arrêt con arresto		Yasargil 24-851-10-07 - 24-851-13-07	24-851-10-07 20 cm / 7 7/8"	24-851-11-07 20 cm / 7 7/8"	24-851-12-07 22,5 cm / 8 7/8"	24-851-13-07 22,5 cm / 8 7/8"

Mikro-Pinzetten

Micro Forceps

Micro-Pinzas

Micro-Pinces

Micro-Pinze

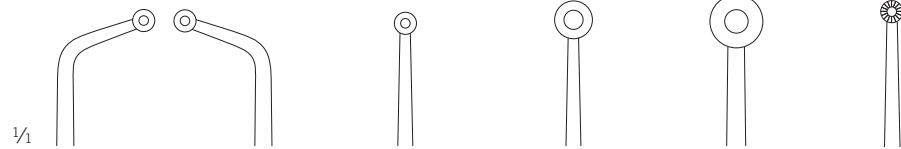

Ø	Samii	Samii	Yasargil-Samii	Yasargil-Samii	Yasargil-Samii	Yasargil
	3.0 mm	3.0 mm	3.0 mm	5.0 mm	7.0 mm	3.0 mm
16,5 cm / 6 5/8"						24-852-20-07
23 cm / 9"	24-852-01-07	24-852-02-07				
24 cm / 9 5/8"			24-852-10-07	24-852-11-07	24-852-12-07	

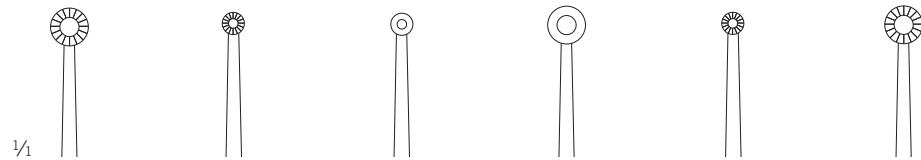

Ø	Yasargil	Yasargil	Yasargil	Yasargil	Yasargil	Yasargil
	5.0 mm	3.0 mm	3.0 mm	5.0 mm	3.0 mm	5.0 mm
16,5 cm / 6 5/8"	24-852-21-07					
20 cm / 7 7/8"		24-852-22-07				
22 cm / 8 5/8"			24-852-23-07	24-852-24-07	24-852-25-07	24-852-26-07

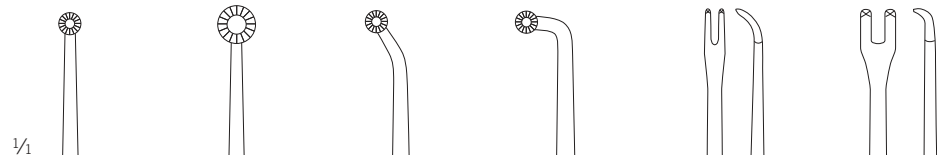

	Heifetz	Heifetz	Yasargil	Yasargil	Yasargil	Yasargil
				45°	90°	
	Ø 3.0 mm	Ø 5.0 mm	Ø 3.0 mm	Ø 3.0 mm	3.0 mm	5.0 mm
22 cm / 8 5/8"	24-852-30-07	24-852-31-07	24-852-40-07	24-852-41-07	24-852-50-07	24-852-51-07



24-852-01-07 -
24-852-78-07

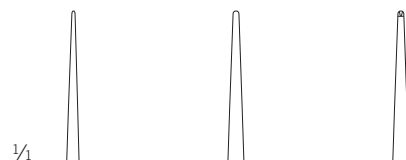

Ø	Yasargil	Yasargil	Yasargil
	0.6 mm	0.9 mm	
			1:2
18 cm / 7 1/8"	24-852-70-07	24-852-71-07	24-852-72-07
20 cm / 7 7/8"	24-852-73-07	24-852-74-07	
22 cm / 8 5/8"	24-852-75-07	24-852-76-07	
24 cm / 9 5/8"	24-852-77-07	24-852-78-07	

Mikro-Pinzetten

Micro Forceps
Micro-Pinzas
Micro-Pinces
Micro-Pinze

Neurochirurgie

Neurosurgery
Neurocirurgia
Neurochirurgie
Neurochirurgia

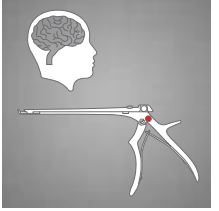

Hunt
24-852-60-07 -
24-852-61-07
20 cm / 7 $\frac{7}{8}$ "



5 mm
24-852-60-07
abgewinkelt
angled
acodado
coudé
angolato



5 mm
24-852-61-07
bajonett
bayonet
bayoneta
baïonnette
baionetta

Mikro-Instrumente

Micro instruments
Micro-instrumentos
Micro instruments
Micro-strumenti

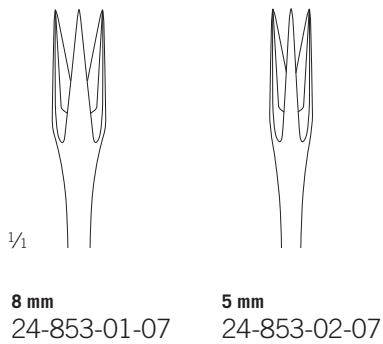

8 mm
24-853-01-07

5 mm
24-853-02-07

Yasargil
24-853-01-07 -
24-853-02-07
20 cm / 7 7/8"
Tumorgabel
Tumor fork
Horquilla para tumor
Fourche à tumeurs
Forchetta per tumore



mit Schutzhülse
with protection sleeve
con tapa de protección
avec écrou-chapeau
con copericho di protezione

24-853-03-07
18,5 cm / 7 3/8"
Gewebekralle
Tissue forceps
Pinza para tejido
Pince à tissus
Pinze per tessuto

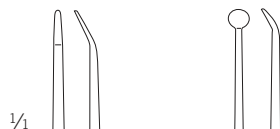

∅	Samii	Samii
1,0 mm	24-854-01-07	
1,5 mm	24-854-02-07	24-854-09-07
2,0 mm	24-854-03-07	
2,5 mm	24-854-04-07	
3,0 mm	24-854-05-07	24-854-10-07
3,5 mm	24-854-06-07	
4,0 mm	24-854-07-07	
4,5 mm		24-854-11-07
5,0 mm	24-854-08-07	
6,0 mm		24-854-12-07

Samii
24-854-01-07 -
24-854-12-07
23 cm / 9"
Tumormesser
Tumor knife
Bisturí para tumor
Couteau à tumeurs
Coltello per tumore

1/2

Mikro-Instrumente

Micro instruments
Micro-instrumentos
Micro instruments
Micro-strumenti

Neurochirurgie

Neurosurgery
Neurocirurgia
Neurochirurgie
Neurochirurgia

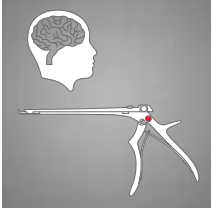

Caspar
24-856-01-07 -
24-856-10-07

Mikro-Dissektor
Micro dissector
Micro-dissector
Micro-dissecteur
Micro-dissetto

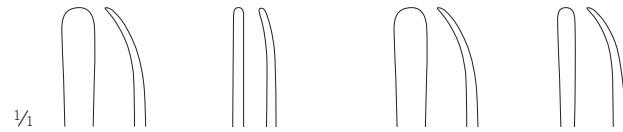

	gerade straight recto droit diritto	gerade straight recto droit diritto	bajonett bayonet bayoneta baïonnette baionetta	bajonett bayonet bayoneta baïonnette baionetta
∅	4,5 mm	1,0 mm	4,5 mm	2,0 mm
20 cm / 7 7/8"		24-856-04-07		
23 cm / 9"	24-856-01-07		24-856-02-07	24-856-03-07

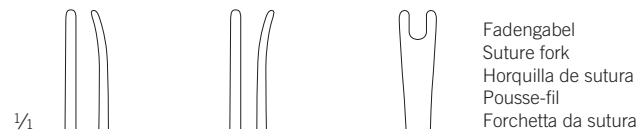

	bajonett bayonet bayoneta baïonnette baionetta	bajonett bayonet bayoneta baïonnette baionetta	bajonett bayonet bayoneta baïonnette baionetta	
∅	1,0 mm	1,0 mm		
20 cm / 7 7/8"	24-856-05-07	24-856-06-07		
23 cm / 9"			24-856-10-07	

Fadengabel
Suture fork
Horquilla de sutura
Pousse-fil
Forchetta da sutura



Samii
24-858-01-07

Lanzettenmesser
Lancet knife
Cuchillo de lanceta
Couteau lancéolaire
Coltello lanceolato

24-858-10-07 -
24-858-30-07

Mikrogefäßmesser
Micro vascular knife
Micro-cuchillo vascular
Micro-couteau vasculaire
Micro-coltello vascolare



	gerade straight recto droit diritto	bajonett bayonet bayoneta baïonnette baionetta	bajonett bayonet bayoneta baïonnette baionetta	bajonett bayonet bayoneta baïonnette baionetta
∅	Samii 1,8 mm	Koos	Koos	Koos
18,5 cm / 7 3/8"		24-858-10-07	24-858-11-07	24-858-12-07
23 cm / 9"	24-858-01-07			

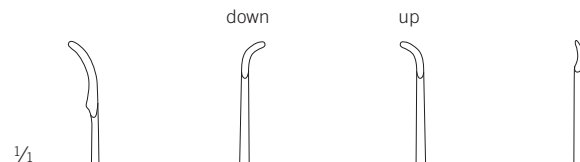

	bajonett bayonet bayoneta baïonnette baionetta	bajonett bayonet bayoneta baïonnette baionetta	bajonett bayonet bayoneta baïonnette baionetta	gerade straight recto droit diritto
∅	Koos	Yasargil	Yasargil	Jacobson
18,5 cm / 7 3/8"	24-858-13-07	24-858-20-07	24-858-21-07	24-858-30-07

Mikro-Instrumente

Micro instruments
Micro-instrumentos
Micro instruments
Micro-strumenti

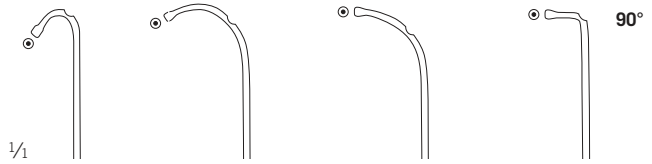

	gebogen curved curvo courbé curvo	gebogen curved curvo courbé curvo	gebogen curved curvo courbé curvo	gebogen curved curvo courbé curvo
18,5 cm / 7 3/8"	24-860-01-07	24-860-02-07	24-860-03-07	24-860-04-07

Yasargil
24-860-01-07 -
24-860-04-07

Fadenführer
Suture guide
Pinza porta-suturas
Pinze guide-fil
Pinze porta-filo

1/2

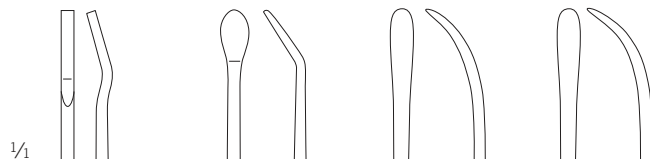

	gerade straight recto droit diritto	gerade straight recto droit diritto	gerade straight recto droit diritto	gerade straight recto droit diritto
18,5 cm / 7 3/8"	24-862-01-07	24-862-02-07	24-862-03-07	24-862-04-07

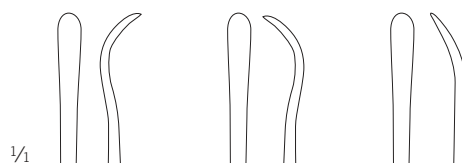

	bajonett bayonet bayoneta baïonnette baionetta	bajonett bayonet bayoneta baïonnette baionetta	bajonett bayonet bayoneta baïonnette baionetta	
18,5 cm / 7 3/8"	24-862-05-07	24-862-06-07	24-862-07-07	

Yasargil
24-862-01-07 -
24-862-20-07

Mikro-Raspatorium
Micro raspatory
Micro-raspador
Micro-raspatoire
Micro-raspatore

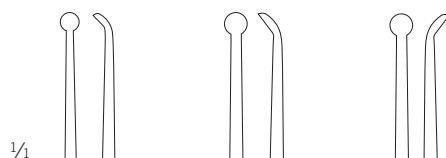

	gerade straight recto droit diritto	gerade straight recto droit diritto	bajonett bayonet bayoneta baïonnette baionetta	
23 cm / 9"	24-862-10-07	24-862-11-07	24-862-20-07	

1/2

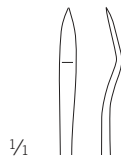
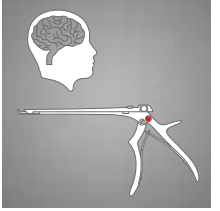

	gerade straight recto droit diritto
18,5 cm / 7 2/8"	24-863-01-07

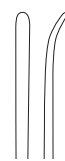

	gerade straight recto droit diritto	gerade straight recto droit diritto	bajonett bayonet bayoneta baïonnette baionetta	bajonett bayonet bayoneta baïonnette baionetta
23 cm / 9"	24-863-10-07	24-863-12-07	24-863-11-07	24-863-13-07







1/2

Yasargil
24-863-01-07 -
24-863-13-07

Mikro-Dissektor
Micro dissector
Micro-dissector
Micro-dissecteur
Micro-dissettore

Mikro-Instrumente, Haken

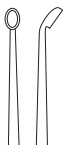
Micro instruments, Hooks
 Micro-instrumentos, Ganchos
 Micro instruments, Crochets
 Micro-strumenti, Uncini

						
$\frac{1}{2}$	$\frac{1}{2}$	$\frac{1}{2}$	$\frac{1}{2}$	$\frac{1}{2}$		
Jacobson 24-864-01-07 18,5 cm / 7 ² / ₈ " Knopfsonde Button probe Sonda abotonada Sonde bouton Sonda bottonuta	Jacobson 24-864-02-07 18,5 cm / 7 ² / ₈ " Doppelsonde Probe, double Sonda doble Sonde double Sonda doppia	Yasargil 24-865-01-07 18,5 cm / 7 ² / ₈ " Mikro-Löffel Micro curette Micro-cucharilla Micro-curette Micro-curetta	24-865-10-07 - 24-865-11-07 23 cm / 9" Mikro-Löffel Micro curette Micro-cucharilla Micro-curette Micro-curetta	24-865-11-07	24-866-01-07 - 24-866-02-07 23 cm / 9" Durahaken Dura Hook Gancho para duramadre Crochet pour dure-mère Uncino per dura-madre	24-866-02-07 stumpf blunt romo mousse smusso

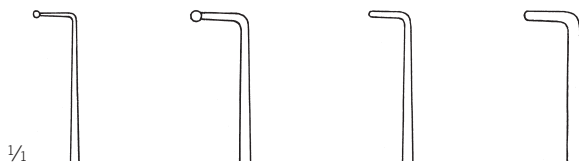
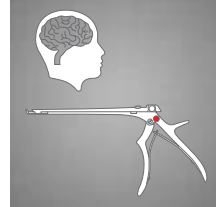

	Krayenbühl	Krayenbühl	Krayenbühl	Krayenbühl
	Fig. 1	Fig. 2	Fig. 3	Fig. 4
19 cm / 7 5/8"	24-940-01-07	24-940-02-07	24-940-03-07	24-940-04-07

24-940-01-07 -
24-940-04-07

Mikro-Häkchen
Micro hooklet
Micro-gancho
Micro-crochet
Micro-uncino

1/2



isoliert
insulated
aislado
isolée
isolato

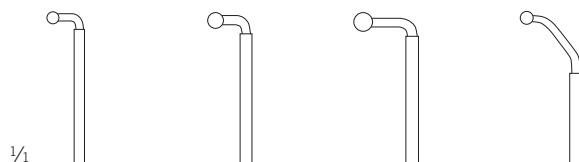

	Caspar	Caspar	Caspar	Caspar
	90°	90°	90°	45°
	5 mm	7 mm	9 mm	11 mm
24,5 cm / 9 5/8"	24-942-05-07	24-942-07-07	24-942-09-07	24-942-11-07

24-942-05-07 -
24-942-11-07

Mikro-Häkchen
Micro hooklet
Micro-gancho
Micro-crochet
Micro-uncino

1/2

Wirbelkörperspreizer

Lamina Spreaders

Separadores para cuerpos vertebrales

Ecarteurs pour corps vertébraux

Separatori per vertebre



1/2

Cloward
24-973-16-07
16 cm / 6 2/8"

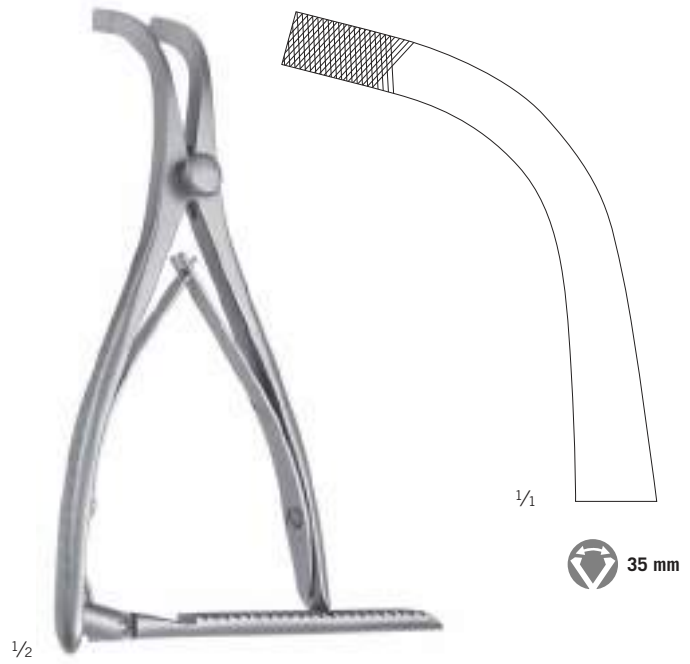

1/2

Cloward
24-974-17-07
16 cm / 6 2/8"

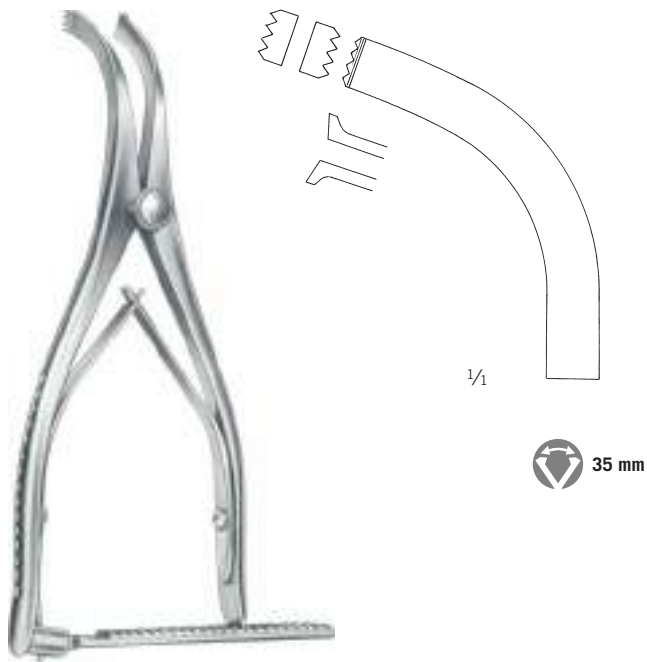

1/1

35 mm

Inge
24-975-17-07
16 cm / 6 2/8"

Wirbelkörperspreizer

Lamina Spreaders

Separadores para cuerpos vertebrales

Ecarteurs pour corps vertébraux

Separatori per vertebre

Neurochirurgie

Neurosurgery

Neurocirurgia

Neurochirurgie

Neurochirurgia

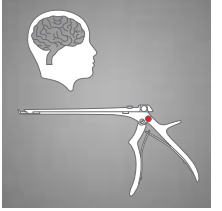

Inge
24-977-27-07
25,5 cm / 10 "

Laminectomiestanzen

Laminectomy Punches

Pinzas cortantes para laminectomía

Pinces emporte-pièces à laminectomie

Pinze taglienti per laminectomia



Ferris-Smith-Kerrison

24-978-01-07 -

24-978-48-14

Stanze mit Auswerfer, zerlegbar

Punch, with ejector, detachable

Perforador con eyector, desmontable

Perforateur avec éjecteur, démontable

Pinze taglienti con espulsore, smontabile

Maulbreite Jaw width Anchura de la boca Largeur de mors Larghezza della bocca		40° aufwärts schneidend cutting upward corte arriba tranchant vers le haut tagliante verso l'alto				90° aufwärts schneidend cutting upward corte arriba tranchant vers le haut tagliante verso l'alto				
		L	18 cm	20 cm	23 cm	28 cm	18 cm	20 cm	23 cm	28 cm
1 mm	○	St	24-978-01-07	24-978-03-07	24-978-05-07	24-978-07-07	24-978-02-07	24-978-04-07	24-978-06-07	24-978-08-07
		SB	24-978-01-14	24-978-03-14	24-978-05-14	24-978-07-14	24-978-02-14	24-978-04-14	24-978-06-14	24-978-08-14
2 mm	◐	St	24-978-09-07	24-978-11-07	24-978-13-07	24-978-15-07	24-978-10-07	24-978-12-07	24-978-14-07	24-978-16-07
		SB	24-978-09-14	24-978-11-14	24-978-13-14	24-978-15-14	24-978-10-14	24-978-12-14	24-978-14-14	24-978-16-14
3 mm	◑	St	24-978-17-07	24-978-19-07	24-978-21-07	24-978-23-07	24-978-18-07	24-978-20-07	24-978-22-07	24-978-24-07
		SB	24-978-17-14	24-978-19-14	24-978-21-14	24-978-23-14	24-978-18-14	24-978-20-14	24-978-22-14	24-978-24-14
4 mm	◒	St	24-978-25-07	24-978-27-07	24-978-29-07	24-978-31-07	24-978-26-07	24-978-28-07	24-978-30-07	24-978-32-07
		SB	24-978-25-14	24-978-27-14	24-978-29-14	24-978-31-14	24-978-26-14	24-978-28-14	24-978-30-14	24-978-32-14
5 mm	◓	St	24-978-33-07	24-978-35-07	24-978-37-07	24-978-39-07	24-978-34-07	24-978-36-07	24-978-38-07	24-978-40-07
		SB	24-978-33-14	24-978-35-14	24-978-37-14	24-978-39-14	24-978-34-14	24-978-36-14	24-978-38-14	24-978-40-14
6 mm	◔	St	24-978-41-07	24-978-43-07	24-978-45-07	24-978-47-07	24-978-42-07	24-978-44-07	24-978-46-07	24-978-48-07
		SB	24-978-41-14	24-978-43-14	24-978-45-14	24-978-47-14	24-978-42-14	24-978-44-14	24-978-46-14	24-978-48-14

Laminektomiestanzen

Laminectomy Punches

Pinzas cortantes para laminectomía

Pinces emporte-pièces à laminectomie

Pinze taglianti per laminectomia

Neurochirurgie

Neurosurgery

Neurocirugía

Neurochirurgie

Neurochirurgia

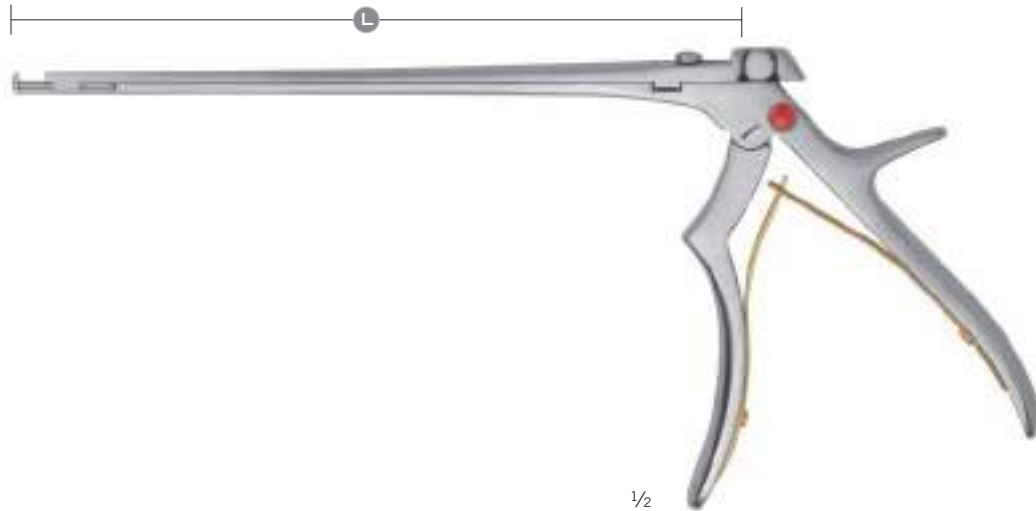
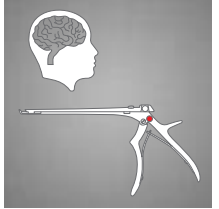

Ferris-Smith-Kerrison

24-979-01-07 -

24-979-48-14

Stanze mit Auswerfer, zerlegbar, **dünne Platte**

Punch, with ejector, detachable, **thin plate**

Perforador con eyector, desmontable, **placa delgada**

Perforateur avec éjecteur, démontable, **plaque mince**

Pinze taglianti con espulsore, smontabile, **piastra sottile**

Maulbreite Jaw width Anchura de la boca Largeur de mors Larghezza della bocca		40° aufwärts schneidend cutting upward corte arriba tranchant vers le haut tagliante verso l'alto				90° aufwärts schneidend cutting upward corte arriba tranchant vers le haut tagliante verso l'alto				
		L	18 cm	20 cm	23 cm	28 cm	18 cm	20 cm	23 cm	28 cm
1 mm	○	St	24-979-01-07	24-979-03-07	24-979-05-07	24-979-07-07	24-979-02-07	24-979-04-07	24-979-06-07	24-979-08-07
		SB	24-979-01-14	24-979-03-14	24-979-05-14	24-979-07-14	24-979-02-14	24-979-04-14	24-979-06-14	24-979-08-14
2 mm	◐	St	24-979-09-07	24-979-11-07	24-979-13-07	24-979-15-07	24-979-10-07	24-979-12-07	24-979-14-07	24-979-16-07
		SB	24-979-09-14	24-979-11-14	24-979-13-14	24-979-15-14	24-979-10-14	24-979-12-14	24-979-14-14	24-979-16-14
3 mm	◑	St	24-979-17-07	24-979-19-07	24-979-21-07	24-979-23-07	24-979-18-07	24-979-20-07	24-979-22-07	24-979-24-07
		SB	24-979-17-14	24-979-19-14	24-979-21-14	24-979-23-14	24-979-18-14	24-979-20-14	24-979-22-14	24-979-24-14
4 mm	◒	St	24-979-25-07	24-979-27-07	24-979-29-07	24-979-31-07	24-979-26-07	24-979-28-07	24-979-30-07	24-979-32-07
		SB	24-979-25-14	24-979-27-14	24-979-29-14	24-979-31-14	24-979-26-14	24-979-28-14	24-979-30-14	24-979-32-14
5 mm	◓	St	24-979-33-07	24-979-35-07	24-979-37-07	24-979-39-07	24-979-34-07	24-979-36-07	24-979-38-07	24-979-40-07
		SB	24-979-33-14	24-979-35-14	24-979-37-14	24-979-39-14	24-979-34-14	24-979-36-14	24-979-38-14	24-979-40-14
6 mm	◔	St	24-979-41-07	24-979-43-07	24-979-45-07	24-979-47-07	24-979-42-07	24-979-44-07	24-979-46-07	24-979-48-07
		SB	24-979-41-14	24-979-43-14	24-979-45-14	24-979-47-14	24-979-42-14	24-979-44-14	24-979-46-14	24-979-48-14

Laminectomiestanzen

Laminectomy Punches

Pinzas cortantes para laminectomía

Pinces emporte-pièces à laminectomie

Pinze taglienti per laminectomia



Ferris-Smith-Kerrison

24-978-90-07 -

24-978-95-14







Stanze mit Auswerfer, zerlegbar, **Langhub**

Punch, with ejector, detachable, **long stroke**

Perforador con eyector, desmontable, **carrera larga**

Perforateur avec éjecteur, démontable, **course longue**

Pinze taglienti con espulsore, smontabile, **corsa lunga**

Maulbreite Jaw width Anchura de la boca Largeur de mors Larghezza della bocca	40° aufwärts schneidend cutting upward corte arriba tranchant vers le haut tagliente verso l'alto	
1 mm 	L 18 cm	
	St 24-978-90-07	
	SB 24-978-90-14	
2 mm 	St 24-978-91-07	
	SB 24-978-91-14	
3 mm 	St 24-978-92-07	
	SB 24-978-92-14	
4 mm 	St 24-978-93-07	
	SB 24-978-93-14	
5 mm 	St 24-978-94-07	
	SB 24-978-94-14	
6 mm 	St 24-978-95-07	
	SB 24-978-95-14	

Laminektomiestanzen

Laminectomy Punches

Pinzas cortantes para laminectomía

Pinces emporte-pièces à laminectomie

Pinze taglianti per laminectomia

Neurochirurgie

Neurosurgery

Neurocirugía

Neurochirurgie

Neurochirurgia

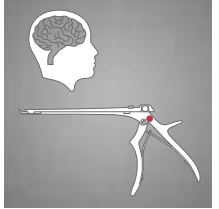

Ferris-Smith-Kerrison

24-979-70-07 -

24-979-75-14







Stanze mit Auswerfer, zerlegbar, **dünne Platte, Langhub,**

Punch, with ejector, detachable, **thin plate, long stroke**

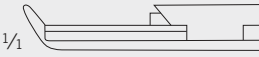
Perforador con eyector, desmontable, **placa delgada, carrera larga**

Perforateur avec éjecteur, démontable, **plaque mince, course longue**

Pinze taglianti con espulsore, smontabile, **piastra sottile, corsa lunga**

Maulbreite Jaw width Anchura de la boca Largeur de mors Larghezza della bocca	40° aufwärts schneidend cutting upward corte arriba tranchant vers le haut tagliante verso l'alto	
1 mm 	L 18 cm	
	St 24-979-70-07	
	SB 24-979-70-14	
2 mm 	St 24-979-71-07	
	SB 24-979-71-14	
3 mm 	St 24-979-72-07	
	SB 24-979-72-14	
4 mm 	St 24-979-73-07	
	SB 24-979-73-14	
5 mm 	St 24-979-74-07	
	SB 24-979-74-14	
6 mm 	St 24-979-75-07	
	SB 24-979-75-14	

Laminectomiestanzen

Laminectomy Punches

Pinzas cortantes para laminectomía

Pinces emporte-pièces à laminectomie

Pinze taglianti per laminectomia

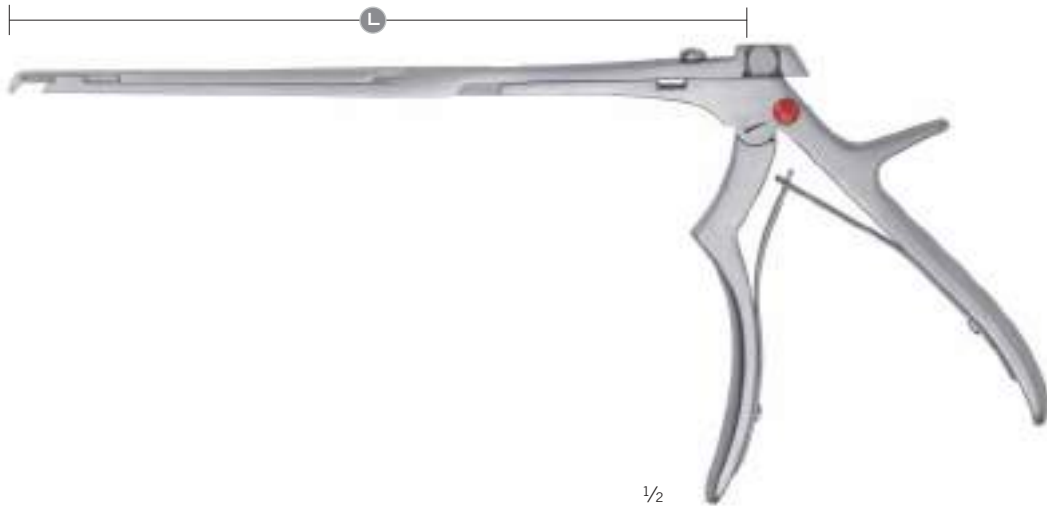

Ferris-Smith-Kerrison

24-978-50-07 -

24-978-85-14

Stanze mit Auswerfer, zerlegbar

Punch, with ejector, detachable

Perforador con eyector, desmontable

Perforateur avec éjecteur, démontable

Pinze taglianti con espulsore, smontabile

Maulbreite Jaw width Anchura de la boca Largeur de mors Larghezza della bocca	40° abwärts schneidend cutting downward desmontable, corte abajo tranchant vers le bas tagliante verso il basso			90° abwärts schneidend cutting downward desmontable, corte abajo tranchant vers le bas tagliante verso il basso			
	L	18 cm	20 cm	23 cm	18 cm	20 cm	23 cm
1 mm	St	24-978-50-07	24-978-52-07	24-978-54-07	24-978-51-07	24-978-53-07	24-978-55-07
	SB	24-978-50-14	24-978-52-14	24-978-54-14	24-978-51-14	24-978-53-14	24-978-55-14
2 mm	St	24-978-56-07	24-978-58-07	24-978-60-07	24-978-57-07	24-978-59-07	24-978-61-07
	SB	24-978-56-14	24-978-58-14	24-978-60-14	24-978-57-14	24-978-59-14	24-978-61-14
3 mm	St	24-978-62-07	24-978-64-07	24-978-66-07	24-978-63-07	24-978-65-07	24-978-67-07
	SB	24-978-62-14	24-978-64-14	24-978-66-14	24-978-63-14	24-978-65-14	24-978-67-14
4 mm	St	24-978-68-07	24-978-70-07	24-978-72-07	24-978-69-07	24-978-71-07	24-978-73-07
	SB	24-978-68-14	24-978-70-14	24-978-72-14	24-978-69-14	24-978-71-14	24-978-73-14
5 mm	St	24-978-74-07	24-978-76-07	24-978-78-07	24-978-75-07	24-978-77-07	24-978-79-07
	SB	24-978-74-14	24-978-76-14	24-978-78-14	24-978-75-14	24-978-77-14	24-978-79-14
6 mm	St	24-978-80-07	24-978-82-07	24-978-84-07	24-978-81-07	24-978-83-07	24-978-85-07
	SB	24-978-80-14	24-978-82-14	24-978-84-14	24-978-81-14	24-978-83-14	24-978-85-14

Laminektomiestanzen

Laminectomy Punches

Pinzas cortantes para laminectomía

Pinces emporte-pièces à laminectomie

Pinze taglianti per laminectomia

Neurochirurgie

Neurosurgery

Neurocirugía

Neurochirurgie

Neurochirurgia

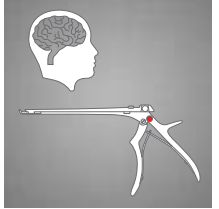

Ferris-Smith-Kerrison

24-979-85-07 -

24-979-96-14







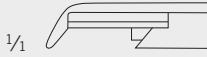

Stanze mit Auswerfer, zerlegbar, **dünne Platte**

Punch, with ejector, detachable, **thin plate**

Perforador con eyector, desmontable, **placa delgada**

Perforateur avec éjecteur, démontable, **plaque mince**

Pinze taglianti con espulsore, smontabile, **piastra sottile**

Maulbreite Jaw width Anchura de la boca Largeur de mors Larghezza della bocca		40° abwärts schneidend cutting downward desmontable, corte abajo tranchant vers le bas tagliante verso il basso		90° abwärts schneidend cutting downward desmontable, corte abajo tranchant vers le bas tagliante verso il basso	
					
1 mm 	L	20 cm	20 cm		
	St	24-979-85-07	24-979-91-07		
	SB	24-979-85-14	24-979-91-14		
2 mm 	St	24-979-86-07	24-979-92-07		
	SB	24-979-86-14	24-979-92-14		
3 mm 	St	24-979-87-07	24-979-93-07		
	SB	24-979-87-14	24-979-93-14		
4 mm 	St	24-979-88-07	24-979-94-07		
	SB	24-979-88-14	24-979-94-14		
5 mm 	St	24-979-89-07	24-979-95-07		
	SB	24-979-89-14	24-979-95-14		
6 mm 	St	24-979-90-07	24-979-96-07		
	SB	24-979-90-14	24-979-96-14		

Laminektomiestanzen

Laminectomy Punches

Pinzas cortantes para laminectomía

Pinces emporte-pièces à laminectomie

Pinze taglienti per laminectomia

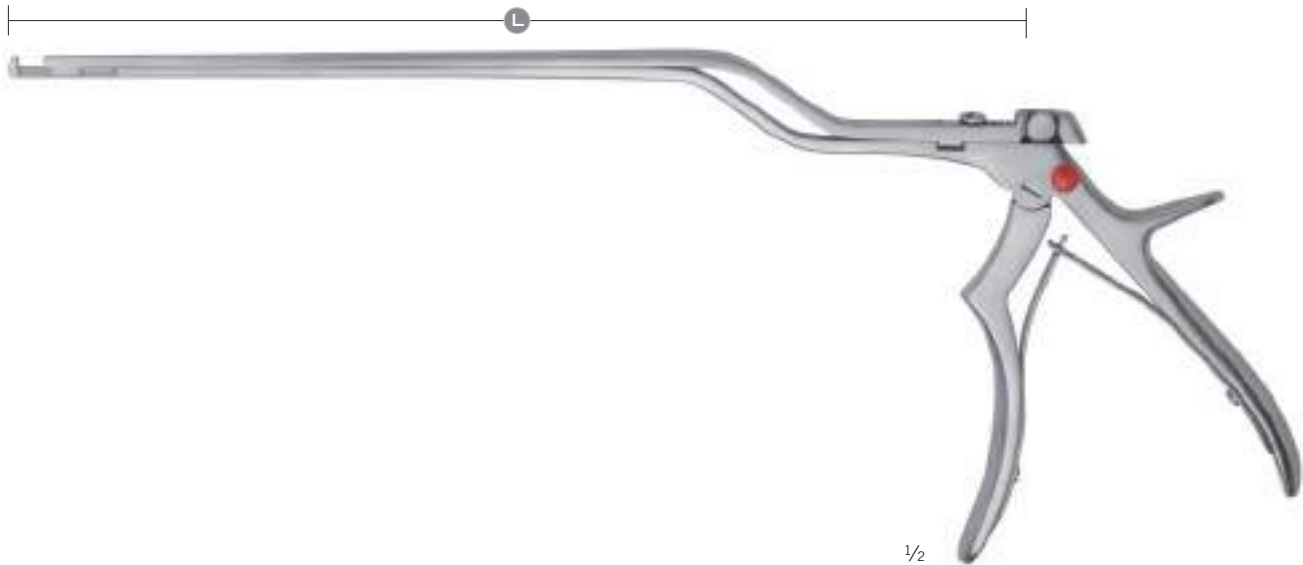

Ferris-Smith-Kerrison

24-980-01-07 -

24-980-20-14

Stanze mit Auswerfer, zerlegbar

Punch, with ejector, detachable

Perforador con eyector, desmontable

Perforateur avec éjecteur, démontable

Pinze taglienti con espulsore, smontabile

Maulbreite Jaw width Anchura de la boca Largeur de mors Larghezza della bocca	40° aufwärts schneidend, bajonett cutting upward, bayonet corte arriba, bayoneta tranchant vers le haut, baïonnette tagliente verso l'alto, baionetta		90° aufwärts schneidend, bajonett cutting upward, bayonet corte arriba, bayoneta tranchant vers le haut, baïonnette tagliente verso l'alto, baionetta		
	L	15 cm	18 cm	15 cm	18 cm
1 mm	St	24-980-01-07	24-980-03-07	24-980-02-07	24-980-04-07
	SB	24-980-01-14	24-980-03-14	24-980-02-14	24-980-04-14
2 mm	St	24-980-05-07	24-980-07-07	24-980-06-07	24-980-08-07
	SB	24-980-05-14	24-980-07-14	24-980-06-14	24-980-08-14
3 mm	St	24-980-09-07	24-980-11-07	24-980-10-07	24-980-12-07
	SB	24-980-09-14	24-980-11-14	24-980-10-14	24-980-12-14
4 mm	St	24-980-13-07	24-980-15-07	24-980-14-07	24-980-16-07
	SB	24-980-13-14	24-980-15-14	24-980-14-14	24-980-16-14
5 mm	St	24-980-17-07	24-980-19-07	24-980-18-07	24-980-20-07
	SB	24-980-17-14	24-980-19-14	24-980-18-14	24-980-20-14

Laminektomiestanzen

Laminectomy Punches

Pinzas cortantes para laminectomía

Pinces emporte-pièces à laminectomie

Pinze taglianti per laminectomia

Neurochirurgie

Neurosurgery

Neurocirugía

Neurochirurgie

Neurochirurgia

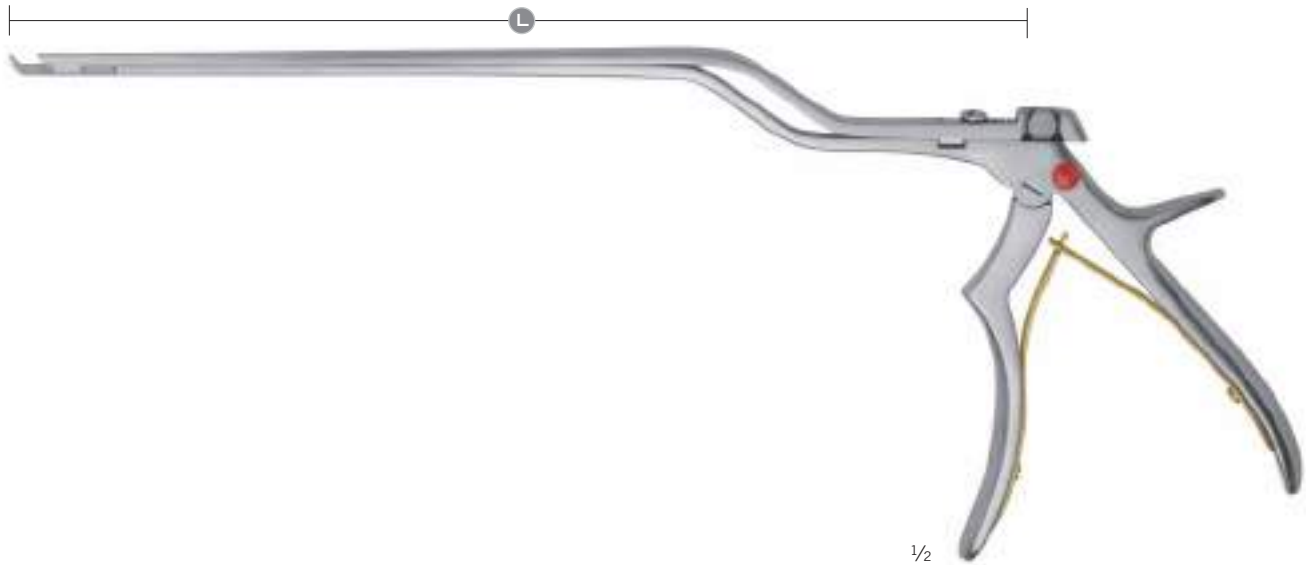
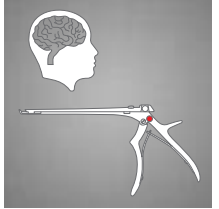

Ferris-Smith-Kerrison

24-979-50-07 -

24-979-69-14

Stanze mit Auswerfer, zerlegbar, **dünne Platte**

Punch, with ejector, detachable, **thin plate**

Perforador con eyector, desmontable, **placa delgada**

Perforateur avec éjecteur, démontable, **plaque mince**

Pinze taglianti con espulsore, smontabile, **piastra sottile**

Maulbreite Jaw width Anchura de la boca Largeur de mors Larghezza della bocca		40° aufwärts schneidend, bajonett cutting upward, bayonet corte arriba, bayoneta tranchant vers le haut, baïonnette tagliante verso l'alto, baionetta		90° aufwärts schneidend, bajonett cutting upward, bayonet corte arriba, bayoneta tranchant vers le haut, baïonnette tagliante verso l'alto, baionetta		
		L	15 cm	18 cm	15 cm	18 cm
1 mm	○	St	24-979-50-07	24-979-52-07	24-979-51-07	24-979-53-07
		SB	24-979-50-14	24-979-52-14	24-979-51-14	24-979-53-14
2 mm	◐	St	24-979-54-07	24-979-56-07	24-979-55-07	24-979-57-07
		SB	24-979-54-14	24-979-56-14	24-979-55-14	24-979-57-14
3 mm	◑	St	24-979-58-07	24-979-60-07	24-979-59-07	24-979-61-07
		SB	24-979-58-14	24-979-60-14	24-979-59-14	24-979-61-14
4 mm	◒	St	24-979-62-07	24-979-64-07	24-979-63-07	24-979-65-07
		SB	24-979-62-14	24-979-64-14	24-979-63-14	24-979-65-14
5 mm	◓	St	24-979-66-07	24-979-68-07	24-979-67-07	24-979-69-07
		SB	24-979-66-14	24-979-68-14	24-979-67-14	24-979-69-14

Laminektomiestanzen

Laminectomy Punches

Pinzas cortantes para laminectomía

Pinces emporte-pièces à laminectomie

Pinze taglianti per laminectomia

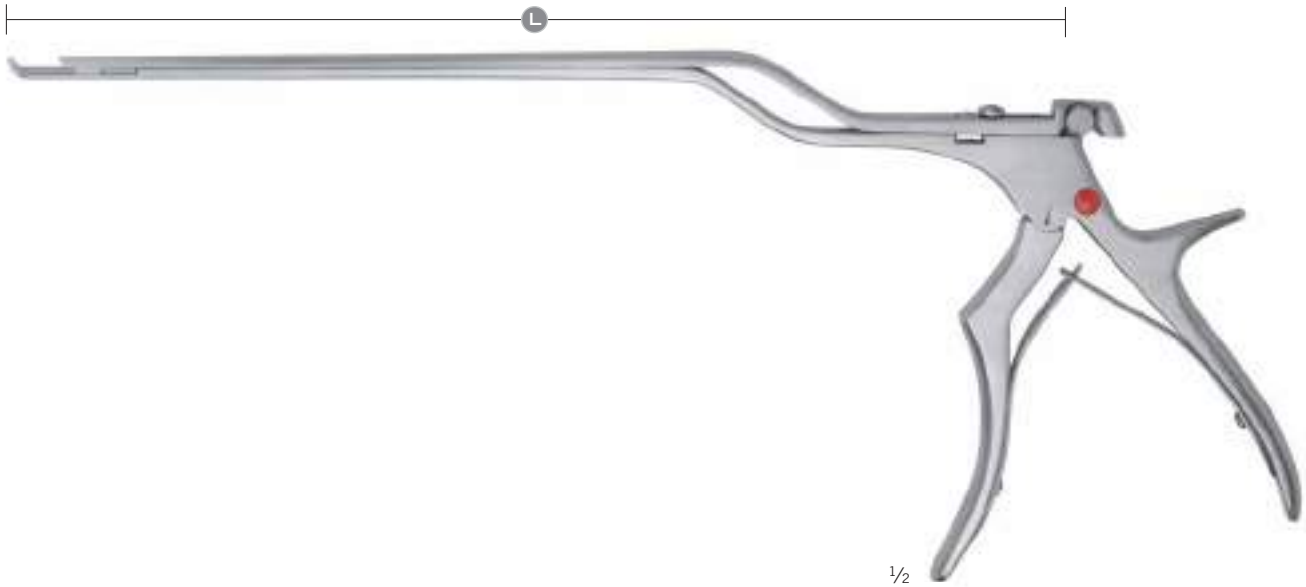

Ferris-Smith-Kerrison

24-980-21-07 -

24-980-25-14







Stanze mit Auswerfer, zerlegbar, **Langhub**

Punch, with ejector, detachable, **long stroke**

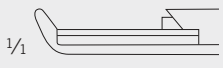
Perforador con eyector, desmontable, **carrera larga**

Perforateur avec éjecteur, démontable, **course longue**

Pinze taglianti con espulsore, smontabile, **corsa lunga**

Maulbreite Jaw width Anchura de la boca Largeur de mors Larghezza della bocca	40° aufwärts schneidend, bajonett cutting upward, bayonet corte arriba, bayoneta tranchant vers le haut, baïonnette tagliante verso l'alto, baionetta	
	L 18 cm	
1 mm 	St 24-980-21-07	
	SB 24-980-21-14	
2 mm 	St 24-980-22-07	
	SB 24-980-22-14	
3 mm 	St 24-980-23-07	
	SB 24-980-23-14	
4 mm 	St 24-980-24-07	
	SB 24-980-24-14	
5 mm 	St 24-980-25-07	
	SB 24-980-25-14	

Laminektomiestanzen

Laminectomy Punches

Pinzas cortantes para laminectomía

Pinces emporte-pièces à laminectomie

Pinze taglianti per laminectomia

Neurochirurgie

Neurosurgery

Neurocirugía

Neurochirurgie

Neurochirurgia

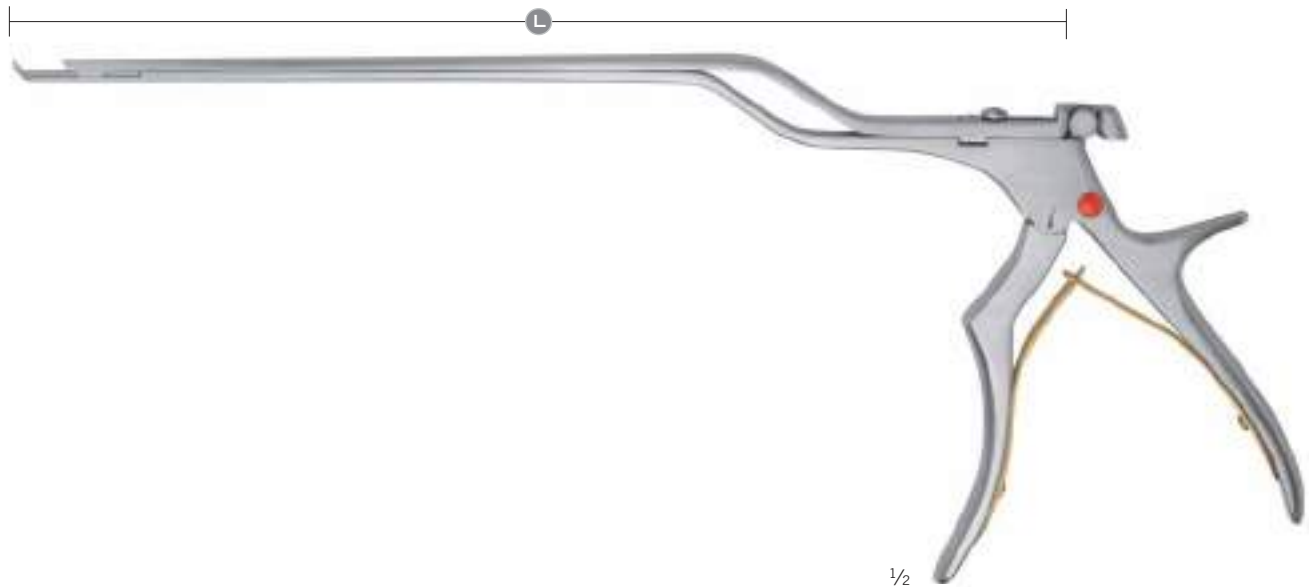
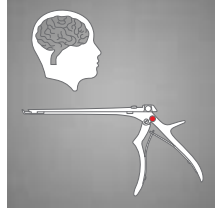

Ferris-Smith-Kerrison

24-979-80-07 -

24-979-84-14

Stanze mit Auswerfer, zerlegbar, **Langhub, dünne Platte**

Punch, with ejector, detachable, **long stroke, thin plate**

Perforador con eyector, desmontable, **carrera larga, placa delgada**

Perforateur avec éjecteur, démontable, **course longue, plaque mince**

Pinze taglianti con espulsore, smontabile, **corsa lunga, piastra sottile**

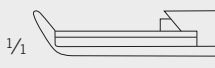
Maulbreite Jaw width Anchura de la boca Largeur de mors Larghezza della bocca		40° aufwärts schneidend, bajonett cutting upward, bayonet corte arriba, bayoneta tranchant vers le haut, baïonnette tagliante verso l'alto, baionetta	
	L	18 cm	
	St	24-979-80-07	
	SB	24-979-80-14	
	St	24-979-81-07	
	SB	24-979-81-14	
	St	24-979-82-07	
	SB	24-979-82-14	
	St	24-979-83-07	
	SB	24-979-83-14	
	St	24-979-84-07	
	SB	24-979-84-14	

Laminektomiestanzen

Laminectomy Punches

Pinzas cortantes para laminectomía

Pinces emporte-pièces à laminectomie

Pinze taglianti per laminectomia



Ferris-Smith-Kerrison

24-980-30-07 -

24-980-44-14









Stanze mit Auswerfer, zerlegbar

Punch, with ejector, detachable

Perforador con eyector, desmontable

Perforateur avec éjecteur, démontable

Pinze taglianti con espulsore, smontabile

Maulbreite Jaw width Anchura de la boca Largeur de mors Larghezza della bocca		40° aufwärts gebogen curved upward curvo arriba coudé vers le haut curva verso l'alto	40° links gebogen curved leftwards curvo izquierda coudé à gauche curva a sinistra	40° rechts gebogen curved rightwards curvo derecha coudé à droite curva a destra
				
		L 20 cm	20 cm	20 cm
1 mm		St 24-980-30-07	24-980-31-07	24-980-32-07
		SB 24-980-30-14	24-980-31-14	24-980-32-14
2 mm		St 24-980-33-07	24-980-34-07	24-980-35-07
		SB 24-980-33-14	24-980-34-14	24-980-35-14
3 mm		St 24-980-36-07	24-980-37-07	24-980-38-07
		SB 24-980-36-14	24-980-37-14	24-980-38-14
4 mm		St 24-980-39-07	24-980-40-07	24-980-41-07
		SB 24-980-39-14	24-980-40-14	24-980-41-14
5 mm		St 24-980-42-07	24-980-43-07	24-980-44-07
		SB 24-980-42-14	24-980-43-14	24-980-44-14

Laminektomiestanzen

Laminectomy Punches

Pinzas cortantes para laminectomía

Pinces emporte-pièces à laminectomie

Pinze taglianti per laminectomia

Neurochirurgie

Neurosurgery

Neurocirugía

Neurochirurgie

Neurochirurgia

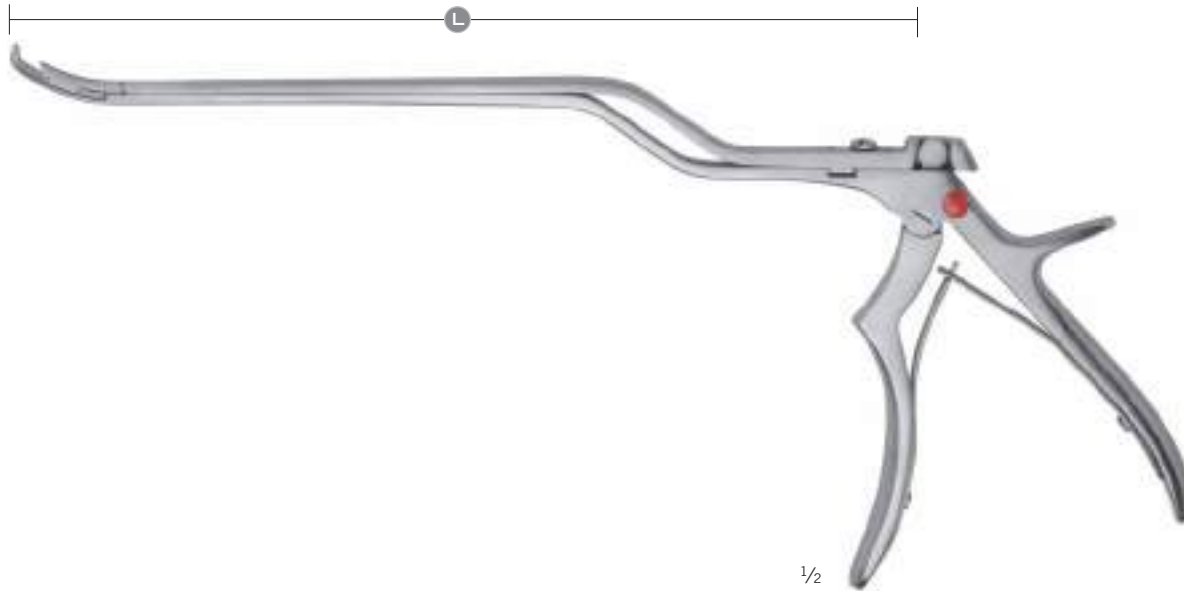
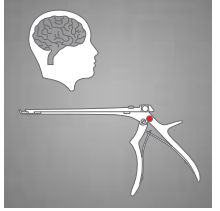

Ferris-Smith-Kerrison
24-980-50-07

Stanze mit Auswerfer, zerlegbar

Punch, with ejector, detachable

Perforador con eyector, desmontable

Perforateur avec éjecteur, démontable

Pinze taglianti con espulsore, smontabile

Maulbreite Jaw width Anchura de la boca Largeur de mors Larghezza della bocca	40° gebogen, bajonett curved, bayonet curvo, bayoneta coudé, baïonnette curva, baionetta	 1/1
	3 mm	



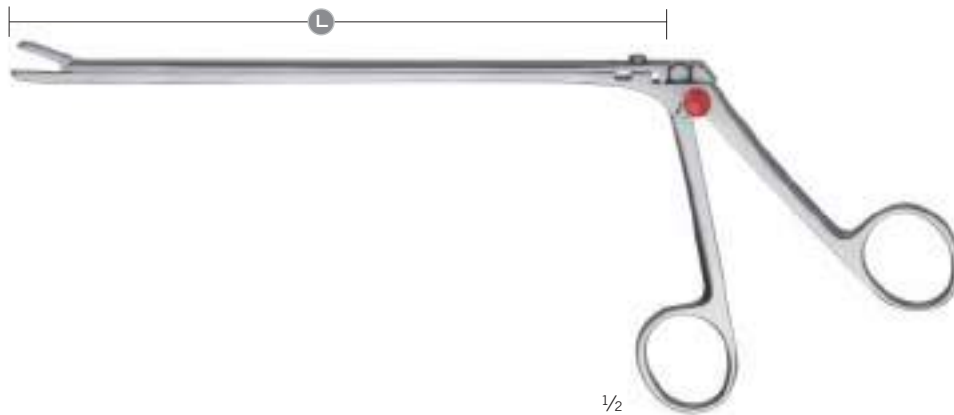

Rongeur

Rongeurs
Pinzas cortantes
Rongeurs
Pinze per afferrare



Caspar
24-981-05-07 -
24-981-20-14



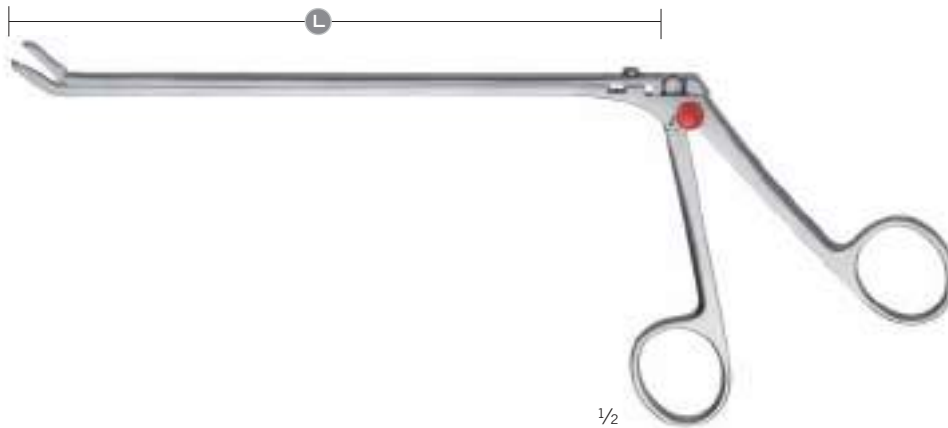
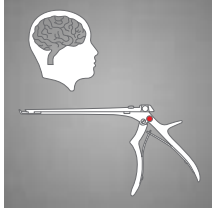

zerlegbar
detachable
desmontable
démontable
smontabile

Maulbreite Jaw width Anchura de la boca Largeur de mors Larghezza della bocca		gerade straight recto droit diritto				
		L	15 cm	18 cm	20 cm	30 cm
2 mm		St	24-981-05-07	24-981-09-07	24-981-13-07	24-981-17-07
		SB	24-981-05-14	24-981-09-14	24-981-13-14	24-981-17-14
3 mm		St	24-981-06-07	24-981-10-07	24-981-14-07	24-981-18-07
		SB	24-981-06-14	24-981-10-14	24-981-14-14	24-981-18-14
4 mm		St	24-981-07-07	24-981-11-07	24-981-15-07	24-981-19-07
		SB	24-981-07-14	24-981-11-14	24-981-15-14	24-981-19-14
5 mm		St	24-981-08-07	24-981-12-07	24-981-16-07	24-981-20-07
		SB	24-981-08-14	24-981-12-14	24-981-16-14	24-981-20-14



Caspar
 24-981-25-07 -
 24-981-40-14

zerlegbar
 detachable
 desmontable
 démontable
 smontabile

Maulbreite Jaw width Anchura de la boca Largeur de mors Larghezza della bocca		30° aufgewinkelt angled upward acodado arrib angulé vers le haut angolato verso l'alto				
		L	15 cm	18 cm	20 cm	30 cm
2 mm		St	24-981-25-07	24-981-29-07	24-981-33-07	24-981-37-07
	SB	24-981-25-14	24-981-29-14	24-981-33-14	24-981-37-14	
3 mm		St	24-981-26-07	24-981-30-07	24-981-34-07	24-981-38-07
	SB	24-981-26-14	24-981-30-14	24-981-34-14	24-981-38-14	
4 mm		St	24-981-27-07	24-981-31-07	24-981-35-07	24-981-39-07
	SB	24-981-27-14	24-981-31-14	24-981-35-14	24-981-39-14	
5 mm		St	24-981-28-07	24-981-32-07	24-981-36-07	24-981-40-07
	SB	24-981-28-14	24-981-32-14	24-981-36-14	24-981-40-14	

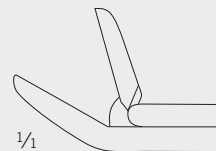



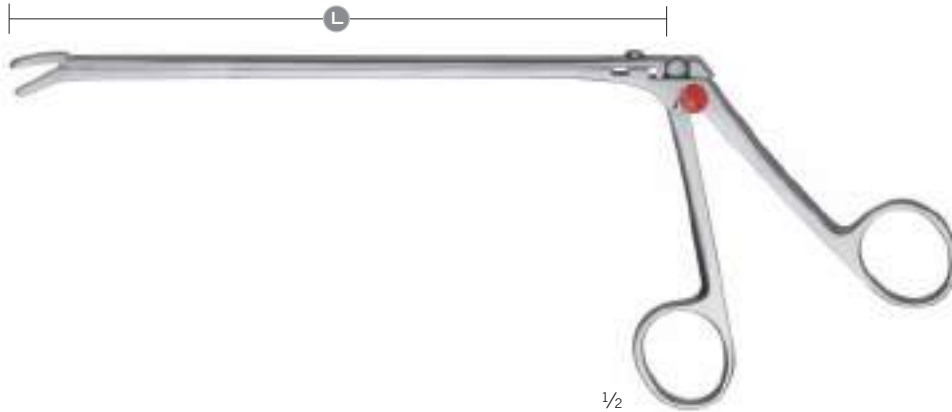

Rongeur

Rongeurs
Pinzas cortantes
Rongeurs
Pinze per afferrare





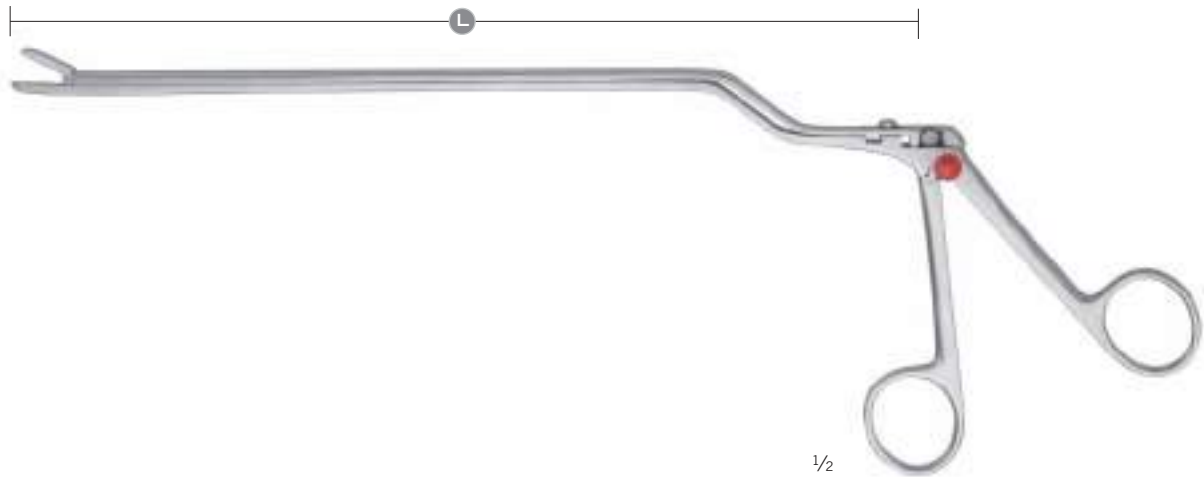
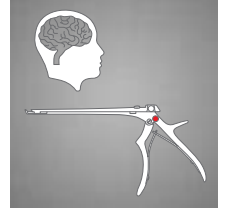

Caspar
24-981-45-07 -
24-981-60-14

zerlegbar
detachable
desmontable
démontable
smontabile

Maulbreite Jaw width Anchura de la boca Largeur de mors Larghezza della bocca	30° abgewinkelt angled downward acodado abajo angulé vers le bas angolato verso il basso				
	L	15 cm	18 cm	20 cm	
2 mm 	St	24-981-45-07	24-981-49-07	24-981-53-07	24-981-57-07
	SB	24-981-45-14	24-981-49-14	24-981-53-14	24-981-57-14
3 mm 	St	24-981-46-07	24-981-50-07	24-981-54-07	24-981-58-07
	SB	24-981-46-14	24-981-50-14	24-981-54-14	24-981-58-14
4 mm 	St	24-981-47-07	24-981-51-07	24-981-55-07	24-981-59-07
	SB	24-981-47-14	24-981-51-14	24-981-55-14	24-981-59-14
5 mm 	St	24-981-48-07	24-981-52-07	24-981-56-07	24-981-60-07
	SB	24-981-48-14	24-981-52-14	24-981-56-14	24-981-60-14



Caspar
 24-981-61-07 -
 24-981-68-14
 zerlegbar
 detachable
 desmontable
 démontable
 smontabile

Maulbreite Jaw width Anchura de la boca Largeur de mors Larghezza della bocca		gerade, bajonett straight, bayonet recto, bayoneta droit, baïonnette diritto, baionetta		
		L	15 cm	18 cm
2 mm		St	24-981-61-07	24-981-65-07
		SB	24-981-61-14	24-981-65-14
3 mm		St	24-981-62-07	24-981-66-07
		SB	24-981-62-14	24-981-66-14
4 mm		St	24-981-63-07	24-981-67-07
		SB	24-981-63-14	24-981-67-14
5 mm		St	24-981-64-07	24-981-68-07
		SB	24-981-64-14	24-981-68-14



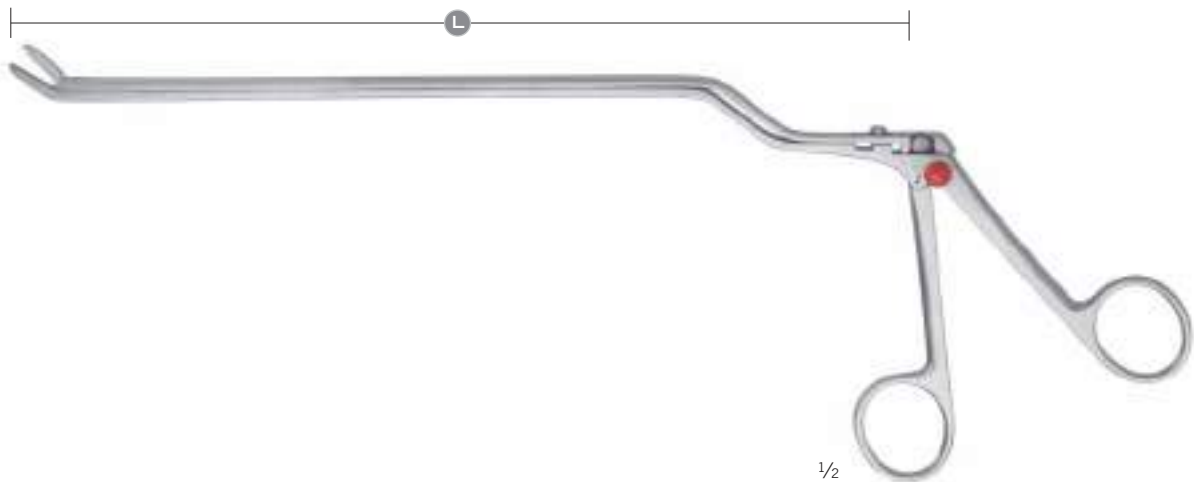

Rongeurs

Rongeurs
Pinzas cortantes
Rongeurs
Pinze per afferrare



Caspar
24-981-71-07 -
24-981-78-14

zerlegbar
detachable
desmontable
démontable
smontabile

Maulbreite Jaw width Anchura de la boca Largeur de mors Larghezza della bocca	30° aufgewinkelt, bajonett angled upward, bayonet acodado arriba, bayoneta angulé vers le haut, baïonnette angolato verso l'alto, baionetta		
	L	15 cm	18 cm
2 mm 	St	24-981-71-07	24-981-75-07
	SB	24-981-71-14	24-981-75-14
3 mm 	St	24-981-72-07	24-981-76-07
	SB	24-981-72-14	24-981-76-14
4 mm 	St	24-981-73-07	24-981-77-07
	SB	24-981-73-14	24-981-77-14
5 mm 	St	24-981-74-07	24-981-78-07
	SB	24-981-74-14	24-981-78-14

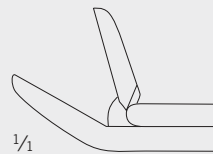

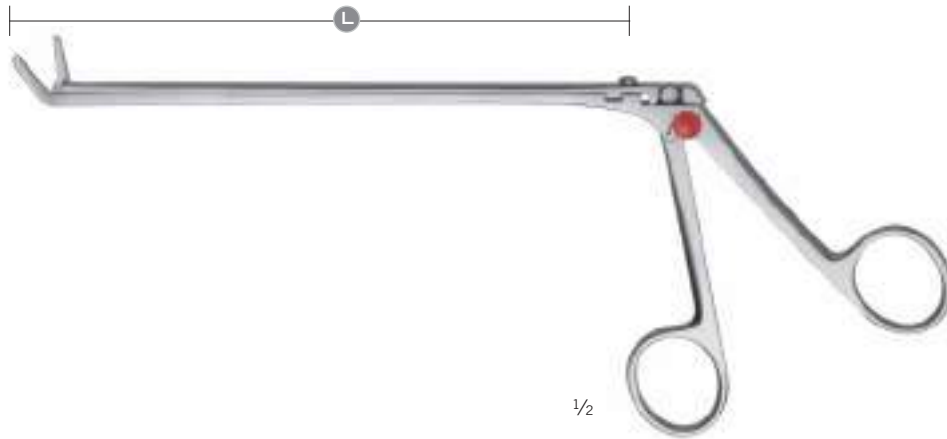
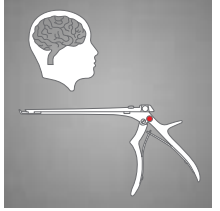

Caspar
 24-981-80-07 -
 24-981-83-14
 zerlegbar
 detachable
 desmontable
 démontable
 smontabile

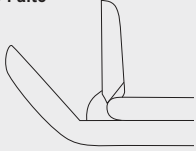
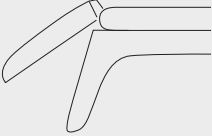
Maulbreite Jaw width Anchura de la boca Largeur de mors Larghezza della bocca 4 mm 	50° aufgewinkelt angled upward acodado arrib angulé vers le haut angolato verso l'alto  1/1		50° abgewinkelt angled downward acodado abajo angulé vers le bas angolato verso il basso 		
	L	18 cm	30 cm	18 cm	30 cm
	St	24-981-80-07	24-981-81-07	24-981-82-07	24-981-83-07
SB	24-981-80-14	24-981-81-14	24-981-82-14	24-981-83-14	



Rongeurs

Rongeurs
Pinzas cortantes
Rongeurs
Pinze per afferrare



Wagner
24-981-91-07 -
24-981-96-14

zerlegbar, **kräftig**
detachable, **strong model**
desmontable, **robusto**
démontable, **robuste**
smontabile, **robusto**

Maulbreite Jaw width Anchura de la boca Largeur de mors Larghezza della bocca		gerade straight recto droit diritto		30° aufgewinkelt angled upward acodado arrib angulé vers le haut angolato verso l'alto		30° abgewinkelt angled downward acodado abajo angulé vers le bas angolato verso il basso	
		$\frac{1}{1}$	$\frac{1}{1}$	$\frac{1}{1}$	$\frac{1}{1}$	$\frac{1}{1}$	$\frac{1}{1}$
3 mm 	L	20 cm	30 cm	20 cm	30 cm	20 cm	30 cm
	st	24-981-91-07	24-981-94-07				
	SB	24-981-91-14	24-981-94-14				
4 mm 	st	24-981-92-07	24-981-95-07	24-981-84-07	24-981-85-07	24-981-86-07	24-981-87-07
	SB	24-981-92-14	24-981-95-14	24-981-84-14	24-981-85-14	24-981-86-14	24-981-87-14
5 mm 	st	24-981-93-07	24-981-96-07				
	SB	24-981-93-14	24-981-96-14				

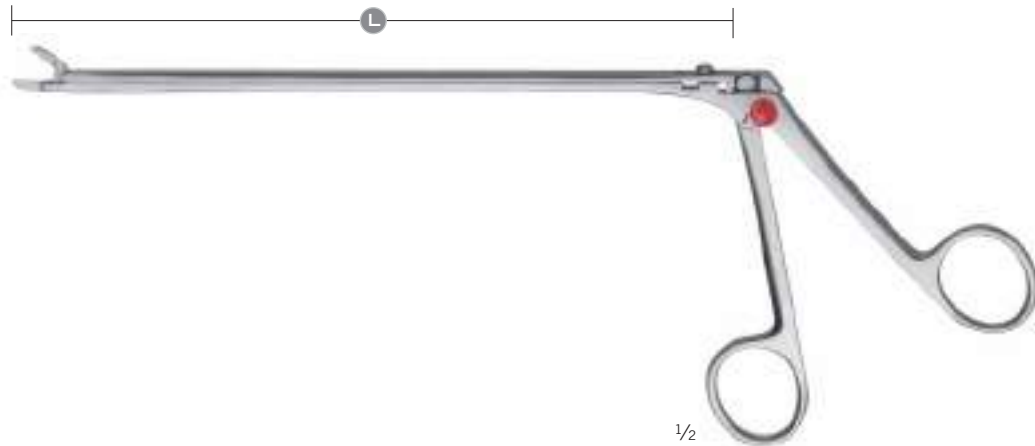
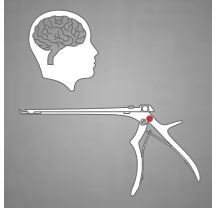

Richter
 24-982-10-07 -
 24-982-13-14
 zerlegbar
 detachable
 desmontable
 démontable
 smontabile

Maulbreite Jaw width Anchura de la boca Largeur de mors Larghezza della bocca	gerade straight recto droit diritto		30° aufgewinkelt angled upward acodado arrib angulé vers le haut angolato verso l'alto	
	$\frac{1}{1}$		$\frac{1}{1}$	
1,0 mm	L	18 cm	18 cm	
	St	24-982-10-07	24-982-11-07	
	SB	24-982-10-14	24-982-11-14	
1,5 mm	St	24-982-12-07	24-982-13-07	
	SB	24-982-12-14	24-982-13-14	

Laminektomieezangen

Laminectomy Rongeurs
 Pinzas para laminectomía
 Pinces pour laminectomie
 Pinze per laminectomia



Hypophysen-Spekula

Pituitary specula

Espéculos para hipófisis

Spéculums pour hypophyse

Specoli per ipofisi

Neurochirurgie

Neurosurgery

Neurocirurgia

Neurochirurgie

Neurochirurgia

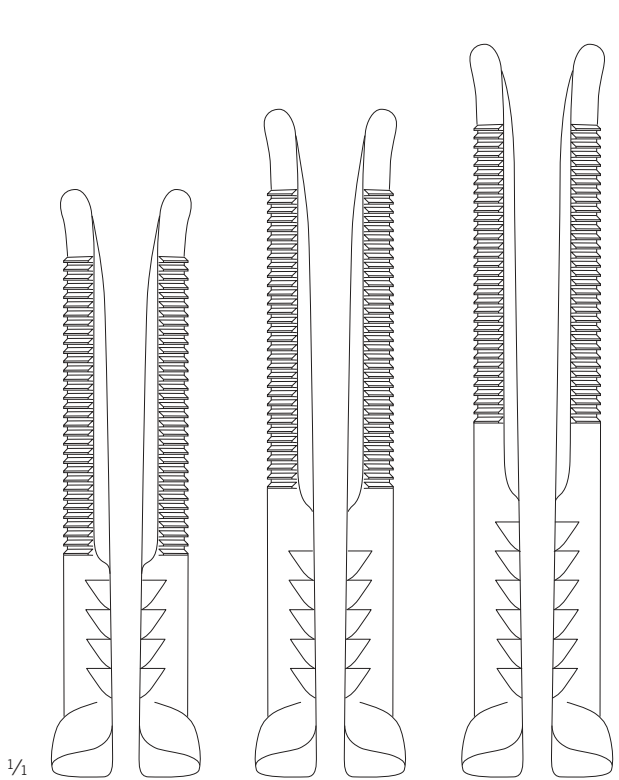
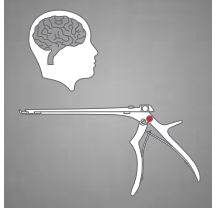

1/1

24-998-08-07

80 x 13 mm



100 mm

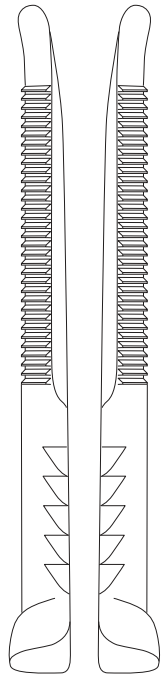

24-998-09-07

90 x 13 mm



100 mm

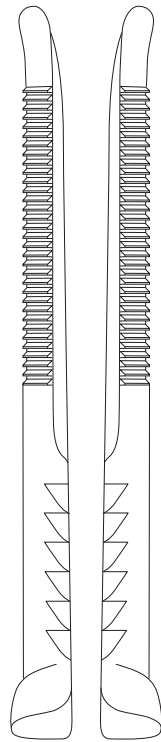

24-998-10-07

100 x 13 mm



100 mm

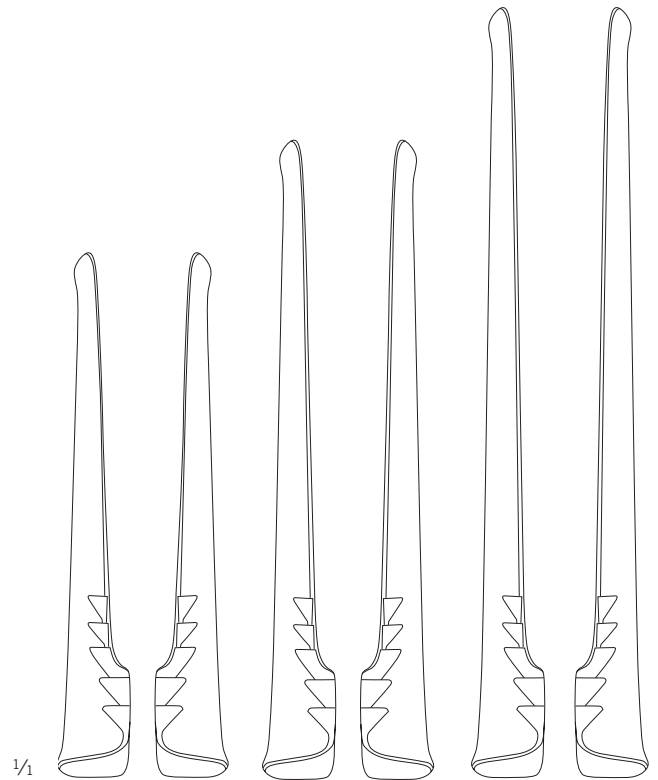

1/1

24-999-07-07

70 x 15 mm



100 mm

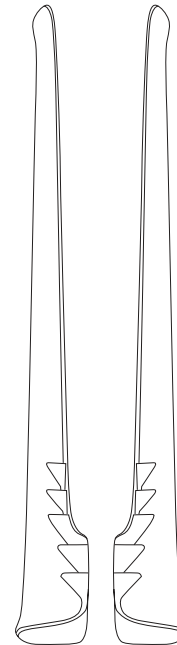

24-999-09-07

90 x 15 mm



100 mm

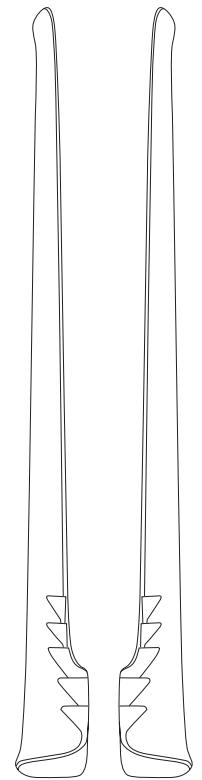

24-999-11-07

110 x 15 mm



100 mm



1/2

1/4

Papavero-Caspar

24-998-08-07 - 24-998-10-07

inklusive Handgriff

incl. handle

incl. mango

manche compris

compreso manico



1/2

Cushing-Landolt

24-999-07-07 - 24-999-11-07

Implantat-Systeme CMF und Trauma
Implant Systems CMF and Trauma
Sistemas de implantes CMF y Trauma
Systèmes d'implant CMF et Trauma
Sistemi di impianto CMF e Trauma

25-26

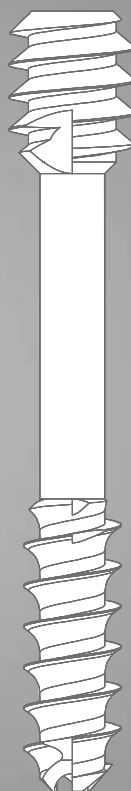
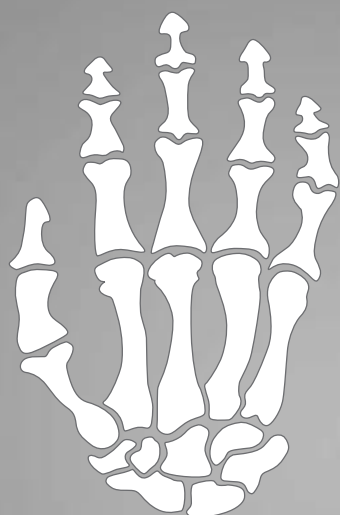

Unser Ordner-System „Hand Surgery“ enthält die gesamte Palette der KLS-Martin-Implantate und -Instrumente für die Handchirurgie.

Our folder system “Hand Surgery” contains the full range of KLS-Martin implants and instruments for hand surgery.

Nuestro sistema de carpetas “Hand Surgery” incluye la gama completa de implantes e instrumentos de KLS-Martin para la cirugía de la mano.

Notre système de dossiers «Hand Surgery» contient l'ensemble de la palette des implants et instruments KLS Martin pour la chirurgie de la main.

Il nostro sistema di cartelle “Hand Surgery” contiene la gamma completa degli impianti e degli strumenti di KLS Martin per la chirurgia della mano.

Unser Katalog „Produktübersicht Traumatologie“ enthält die gesamte Palette der KLS-Martin-Instrumente für die Knochenchirurgie.

Our catalog “Traumatology Product Overview” contains the full range of KLS-Martin implants and instruments for bone surgery.

Nuestro catálogo “Traumatology Product Overview” incluye la gama completa de los implantes e instrumentos de KLS-Martin para la cirugía ósea.

Notre catalogue «Traumatology Product Overview» contient l'ensemble de la palette des implants et instruments KLS Martin pour la chirurgie osseuse

Il nostro catalogo “Traumatology Product Overview” contiene la gamma completa degli impianti e degli strumenti di KLS Martin per la chirurgia ossea

Unser Ordner-System „CMF Osteosynthesis“ enthält die gesamte Palette der KLS-Martin-Implantate und -Instrumente für die Mund-, Kiefer- und Gesichtschirurgie.

Our folder system “CMF Osteosynthesis” contains the full range of KLS-Martin implants and instruments for cranio-maxillofacial surgery.

Nuestro sistema de carpetas “CMF Osteosynthesis” incluye la gama completa de implantes e instrumentos de KLS-Martin para la cirugía oral y maxilofacial.

Notre système de dossiers «CMF Osteosynthesis» contient l'ensemble de la palette des implants et instruments KLS Martin pour la chirurgie buccale et maxillofaciale.

Il nostro sistema di cartelle “CMF Osteosynthesis” contiene la gamma completa degli impianti e degli strumenti di KLS Martin per la chirurgia orale-maxillo-facciale.



Tracheotomie
Tracheotomy
Traqueotomía
Trachéotomie
Tracheotomia

27

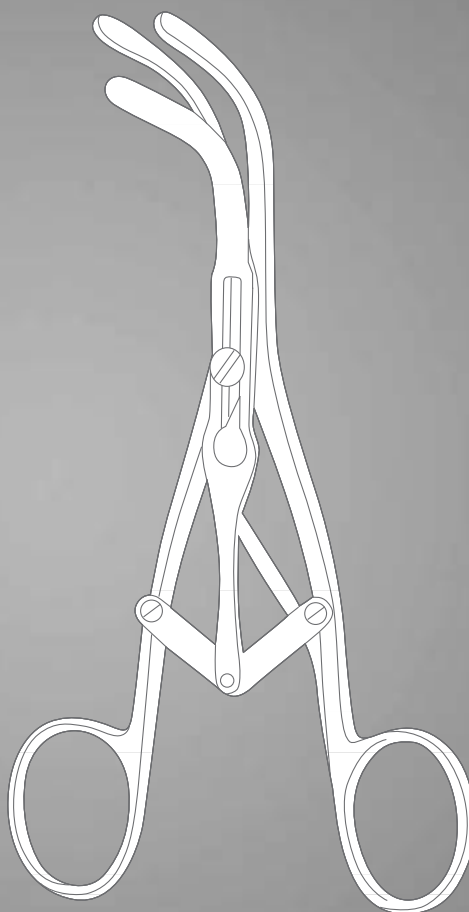

Trachealdilatatoren

Tracheal Dilators

Dilatadores traqueales

Dilatateurs pour la trachéotomie

Dilatatori per tracheotomia



Laborde
27-113-14-07
14 cm / 5 $\frac{4}{8}$ "



Trousseau
27-115-14-07
14,5 cm / 5 $\frac{6}{8}$ "

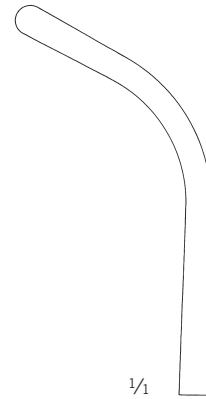

Trachealhaken

Tracheal Hooks
Ganchos traqueales
Ecarteurs pour trachéotomie
Uncini tracheali

Tracheotomie

Tracheotomy
Traqueotomía
Trachéotomie
Tracheotomia

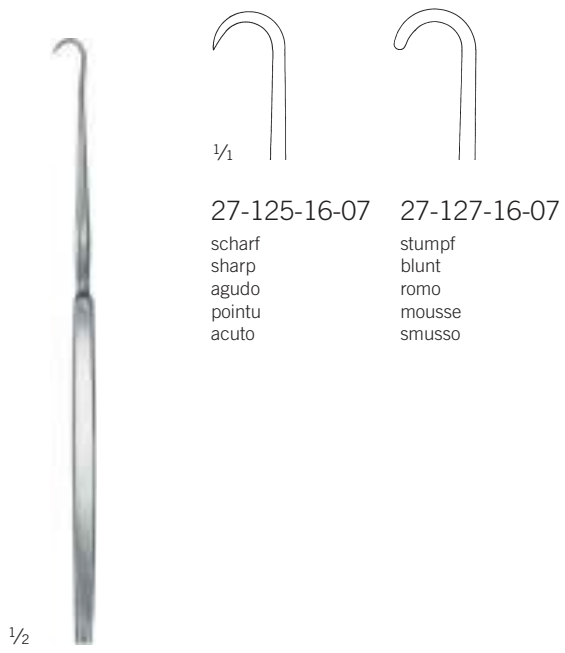
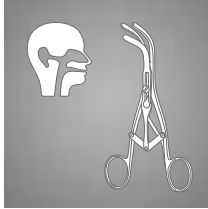

27-125-16-07

scharf
sharp
agudo
pointu
acuto

27-127-16-07

stumpf
blunt
romo
mousse
smusso

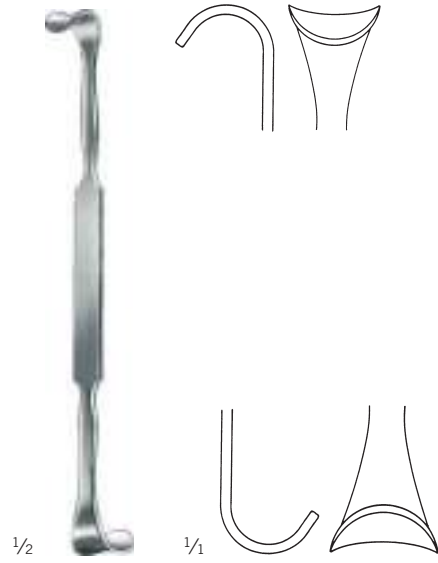

Rose

27-143-13-07

15,5 cm / 6 1/8"

Iterson

27-125-16-07 -

27-127-16-07

17 cm / 6 5/8"



Luer

27-145-11-07

11 cm / 4 3/8"



Lukens

27-151-17-07

17,5 cm / 6 7/8"



Jackson

27-155-17-07

18 cm / 7 1/8"

Kropfsonden, Kropffasszangen

Goitre Enucleator, Goitre Grasping Forceps
 Sondas para bocio, Pinzas para coger el bocio
 Spatules à goitre, Pincas à goitre
 Sonde per gozzo, Pinze per gozzo

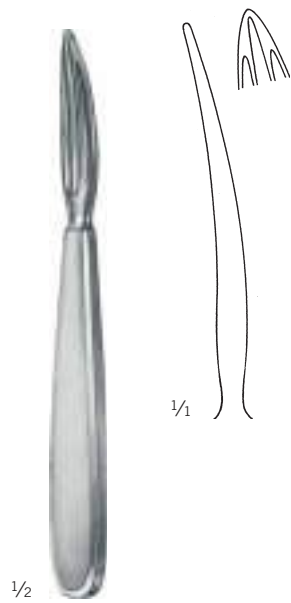

Kocher
 27-411-15-07
 15,5 cm / 6 1/8"

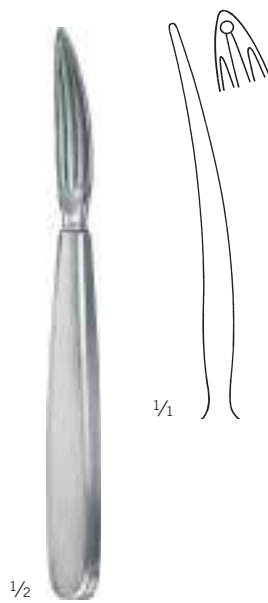

Kocher
 27-413-15-07
 15,5 cm / 6 1/8"
 mit Loch
 with eye
 con agujero
 avec trou
 con foro



Lahey
 27-449-15-07 -
 27-449-20-07

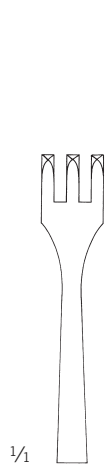

27-449-15-07
 15,5 cm / 6 1/8"



3:3

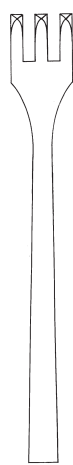

27-449-20-07
 20 cm / 7 7/8"



3:3

Dermatologie
Dermatology
Dermatología
Dermatologie
Dermatologia

28

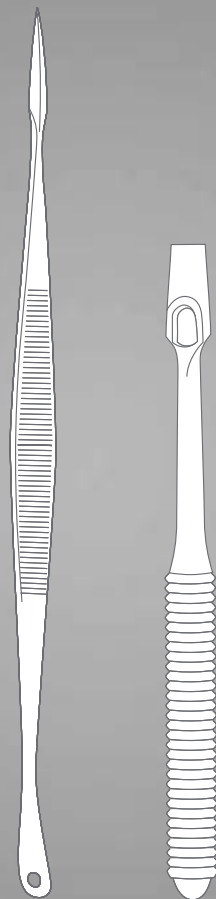

Milienmesser, Lupusinstrumente

Milium Knife, Lupus Instruments

Chuchillo para milium, Instrumentos para lupus

Couteau pour milium, Instruments pour les lupus

Bisturi per milie, Strumenti per lupus



Vidal
28-135-14-07
13 cm / 5 1/8"

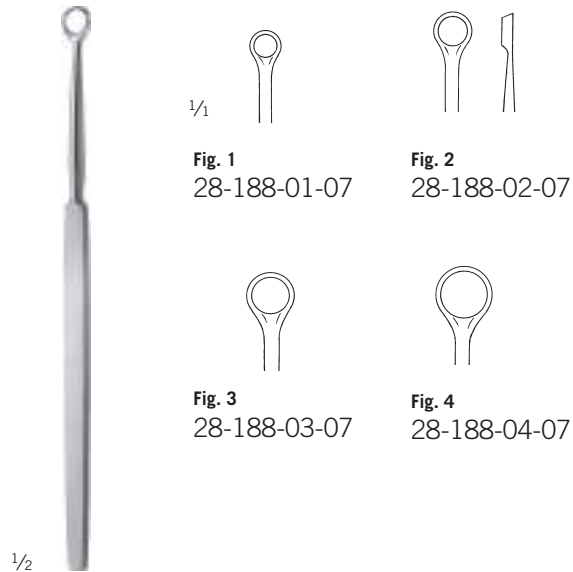

Fox
28-188-01-07 -
28-188-04-07
14 cm / 5 4/8"

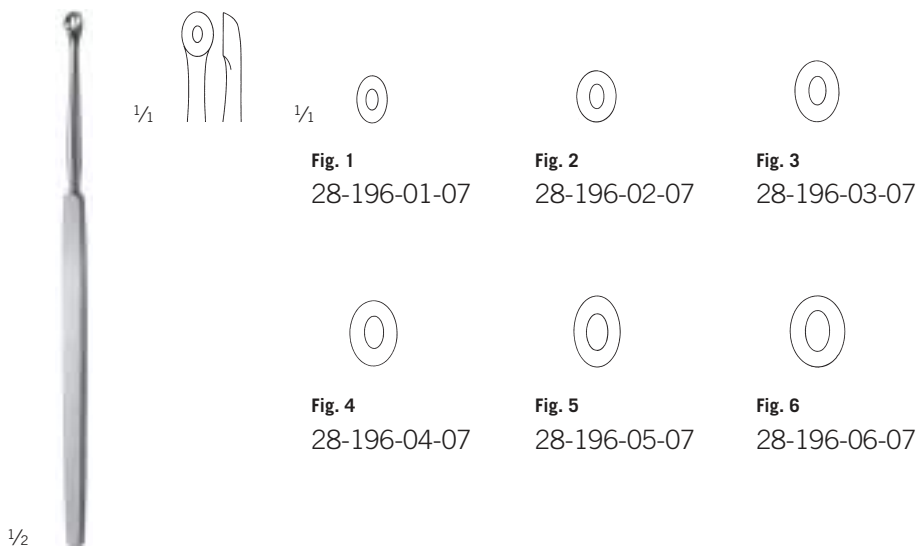

Wolff
28-196-01-07 -
28-196-06-07
14 cm / 5 4/8"

Hauthäkchen, Hauttrephinen

Skin Hooklets, Dermal Punches
 Ganchitos para piel, Trépanos para piel
 Erignes cutanées, Trépan cutanés
 Uncini cutanei, Trefine cutanee

Dermatologie

Dermatology
 Dermatología
 Dermatologie
 Dermatologia

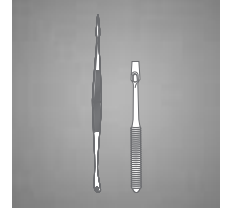

1/1 ?

1/2

Kilner
 28-203-15-07
 14,5 cm / 5 9/16"
 scharf
 sharp
 agudo
 pointu
 acuto



1/1 ?

Fig. 1
 28-207-18-07
 kleiner Radius, scharf
 small radius, sharp
 radio pequeño, agudo
 petit rayon, affûté
 raggio piccolo, acuto

1/1 ?

Fig. 2
 28-209-18-07
 großer Radius, scharf
 large radius, sharp
 radio grande, agudo
 grand rayon, affûté
 raggio grande, acuto

1/2

Gillies
 28-207-18-07 -
 28-209-18-07
 18 cm / 7 1/8"



1/2

Kaye
 28-215-03-07 -
 28-215-04-07
 13 cm / 5 1/8"

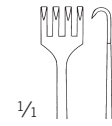

1/1

28-215-03-07

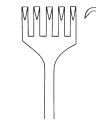

28-215-04-07



1/2

Keyes
 28-240-02-07 -
 28-240-08-07
 11 cm / 4 3/8"

1/1 ○

Ø 2,0 mm

28-240-02-07

○

Ø 3,0 mm

28-240-03-07

○

Ø 4,0 mm

28-240-04-07

1/1 ○

Ø 5,0 mm

28-240-05-07

○

Ø 6,0 mm

28-240-06-07

○

Ø 7,0 mm

28-240-07-07

○

Ø 8,0 mm

28-240-08-07

Komedoneninstrumente

Comedone Extractors
 Extractores para comedones
 Tire-comédons
 Tiracomedoni

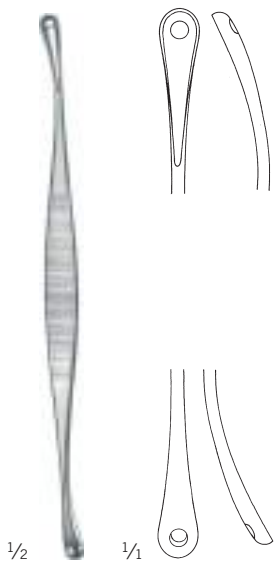

Unna
 28-261-14-07
 14,5 cm / 5 5/8"



Unna
 28-263-14-07
 14 cm / 5 4/8"



Saalfeld
 28-271-10-07
 11 cm / 4 3/8"

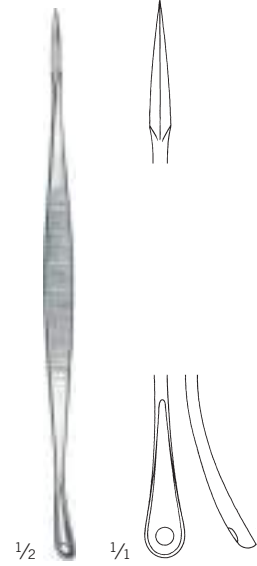

Saalfeld
 28-275-14-07
 14,5 cm / 5 6/8"

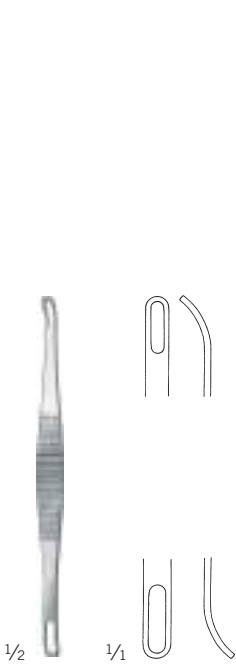

Schamberg
 28-279-10-07
 9,5 cm / 3 5/8"



mit Schutzkappe aus Metall
 with protective metal cap
 con capuchón protector metálico
 avec capuchon en fer
 con coperchio di protezione in metallo

Katsch
 28-294-14-07
 16 cm / 6 2/8"



Unna-Vidal
 28-296-11-07
 11 cm / 4 3/8"

Face-Lift-Klemmen, Face-Lift-Scheren

Face-lift Forceps, Face-lift Scissors

Pinza para Face-lift, Tijeras para Face-lift

Pinces pour Face-lift, Ciseaux pour Face-lift

Pinze per Face-lift, Forbici per Face-lift

Dermatologie

Dermatology

Dermatología

Dermatologie

Dermatologia

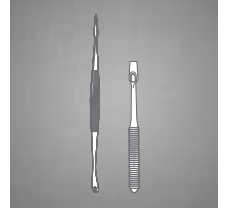

d'Assumpção
28-300-15-07
16 cm / 6 2/8"

TC GOLD

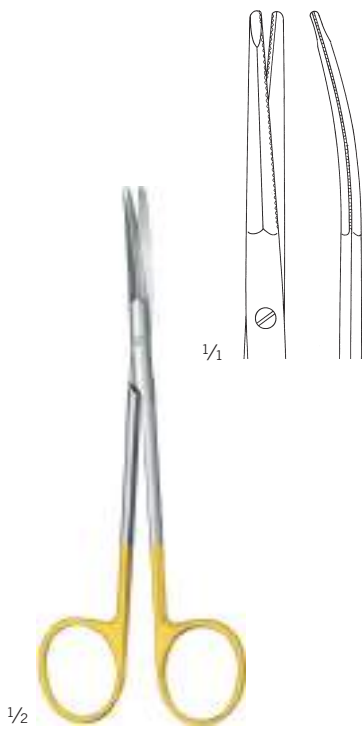

Gregory
28-501-14-07
14,5 cm / 5 5/8"

gezahnt
toothed
dentada
dentelée
dentate



Kaye
28-503-15-07 -
28-503-18-07

eine Schneide gezahnt
one toothed cutting edge
una hoja dentada
une lame dentelée
una lama dentata



Stella-S
28-505-18-07
18 cm / 7"

eine Schneide gezahnt
one toothed cutting edge
una hoja dentada
une lame dentelée
una lama dentata

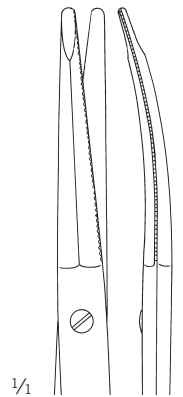

Face-Lift-Scheren

Face-lift Scissors

Tijeras para Face-lift

Ciseaux pour Face-lift

Forbici per Face-lift

TC GOLD

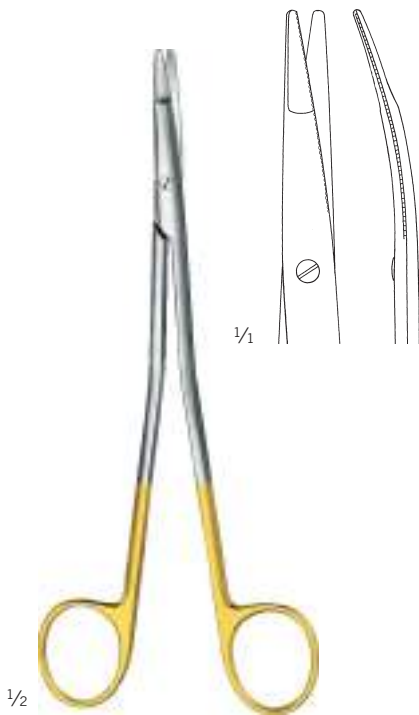

Gorney
28-521-18-07

17,5 cm / 6 7/8"

eine Schneide gezahnt
one toothed cutting edge
una hoja dentada
une lame dentelée
una lama dentata

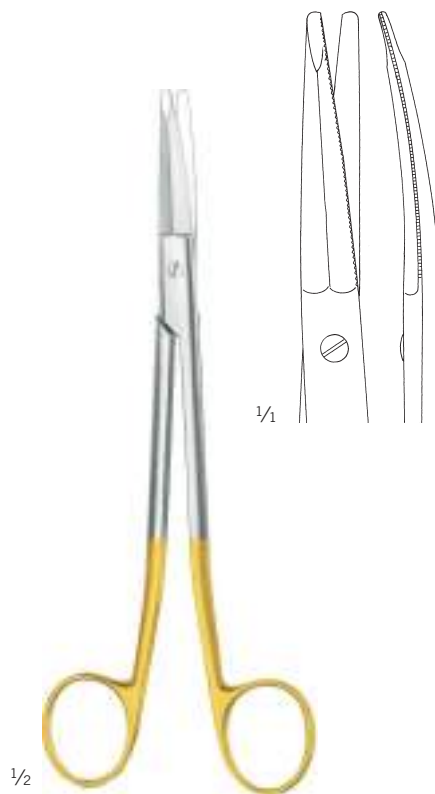

Freeman-Kaye
28-525-18-07

18 cm / 7"

eine Schneide gezahnt
one toothed cutting edge
una hoja dentada
une lame dentelée
una lama dentata

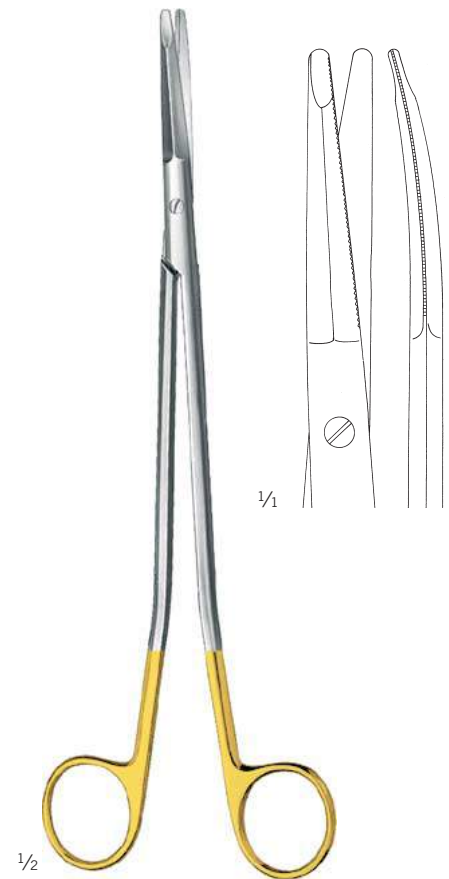

Freeman
28-529-23-07

23 cm / 9"

eine Schneide gezahnt
one toothed cutting edge
una hoja dentada
une lame dentelée
una lama dentata

Magen, Darm, Rektum
Stomach, Intestines, Rectum
Estómago, Intestinos, Recto
Estomac, Intestins, Rectum
Stomaco, Intestini, Retto

30

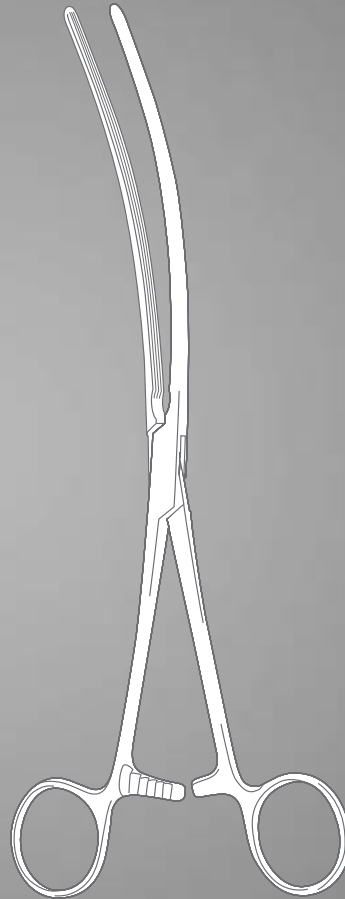
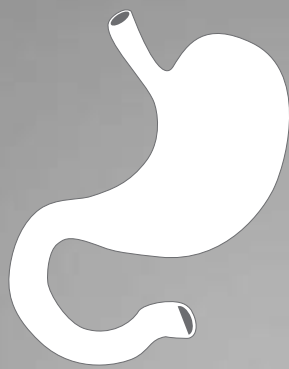











Darm- und Gewebefasszangen

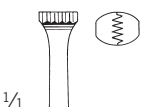

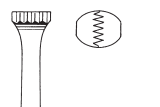
Intestinal and Tissue Grasping Forceps

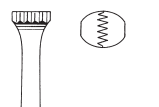
Pinzas para intestinos y tejidos

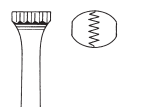
Pinces pour saisir intestins et tissus

Pinze per afferrare intestino e tessuti

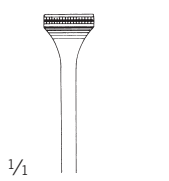
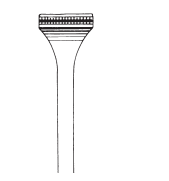
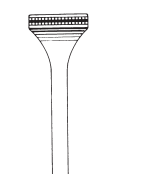
 <p>1/2</p>	 <p>1/1</p> <p>4:5</p>	 <p>1/2</p>	 <p>1/1</p> <p>30-132-15-07 15,5 cm / 6 1/8"</p>  <p>4:5</p>	 <p>30-134-15-07 15,5 cm / 6 1/8"</p>  <p>5:6</p>	 <p>30-134-19-07 19 cm / 7 4/8"</p>  <p>5:6</p>	 <p>30-134-25-07 25,5 cm / 10"</p>  <p>5:6</p>
<p>Allis-Baby 30-130-12-07 13 cm / 5 1/8"</p>	<p>Allis 30-132-15-07 - 30-134-25-07</p>					

<p>Atrauma</p>  <p>1/2</p>	 <p>1/1</p> <p>30-136-16-07 15,5 cm / 6 1/8"</p>	 <p>30-136-20-07 20 cm / 7 7/8"</p>	 <p>30-136-25-07 24,5 cm / 9 5/8"</p>	 <p>30-136-30-07 30 cm / 11 6/8"</p>
<p>Allis 30-136-16-07 - 30-136-30-07</p>				

Darm- und Gewebefasszangen

Intestinal and Tissue Grasping Forceps

Pinzas para intestinos y tejidos

Pinces pour saisir intestins et tissus

Pinze per afferrare intestino e tessuti

Magen, Darm, Rektum

Stomach, Intestines, Rectum

Estómago, Intestinos, Recto

Estomac, Intestins, Rectum

Stomaco, Intestini, Retto

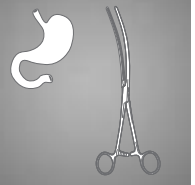

Allis-Adair
30-138-15-07
16 cm / 6 2/8"



Boys-Allis
30-142-15-07
15,5 cm / 6"

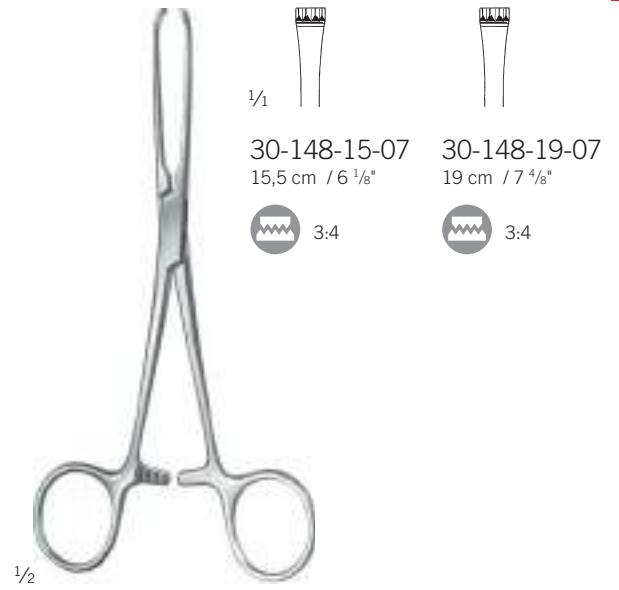

Judd-Allis
30-148-15-07 -
30-148-19-07



Thoms-Allis
30-150-20-07
20,5 cm / 8 1/8"



Allis
30-154-20-07
20 cm / 7 7/8"

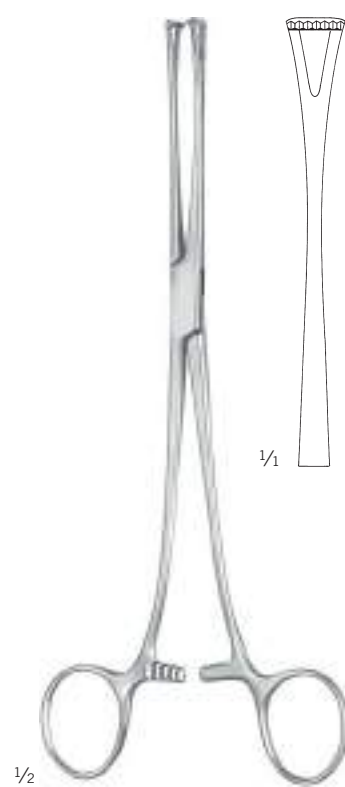

Lockwood
30-170-20-07
20 cm / 7 7/8"

Darm- und Gewebefasszangen

Intestinal and Tissue Grasping Forceps

Pinzas para intestinos y tejidos

Pinces pour saisir intestins et tissus

Pinze per afferrare intestino e tessuti

TC GOLD

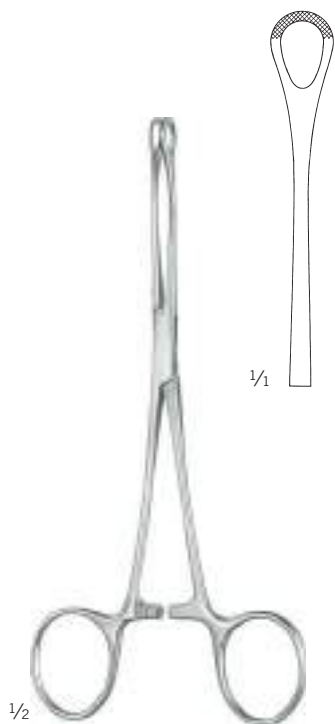

$\frac{1}{2}$

Williams
30-186-16-07
16,5 cm / 6 $\frac{4}{8}$ "



$\frac{1}{2}$

Babcock
30-190-16-07 -
30-190-20-07

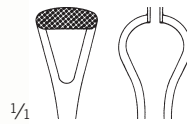

$\frac{1}{4}$

30-190-16-07
16,5 cm / 6 $\frac{4}{8}$ "

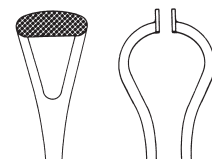

$\frac{1}{4}$

30-190-20-07
21 cm / 8 $\frac{2}{8}$ "

Darm- und Gewebefasszangen

Intestinal and Tissue Grasping Forceps

Pinzas para intestinos y tejidos

Pinces pour saisir intestins et tissus

Pinze per afferrare intestino e tessuti

Magen, Darm, Rektum

Stomach, Intestines, Rectum

Estómago, Intestinos, Recto

Estomac, Intestins, Rectum

Stomaco, Intestini, Retto

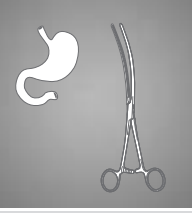

30

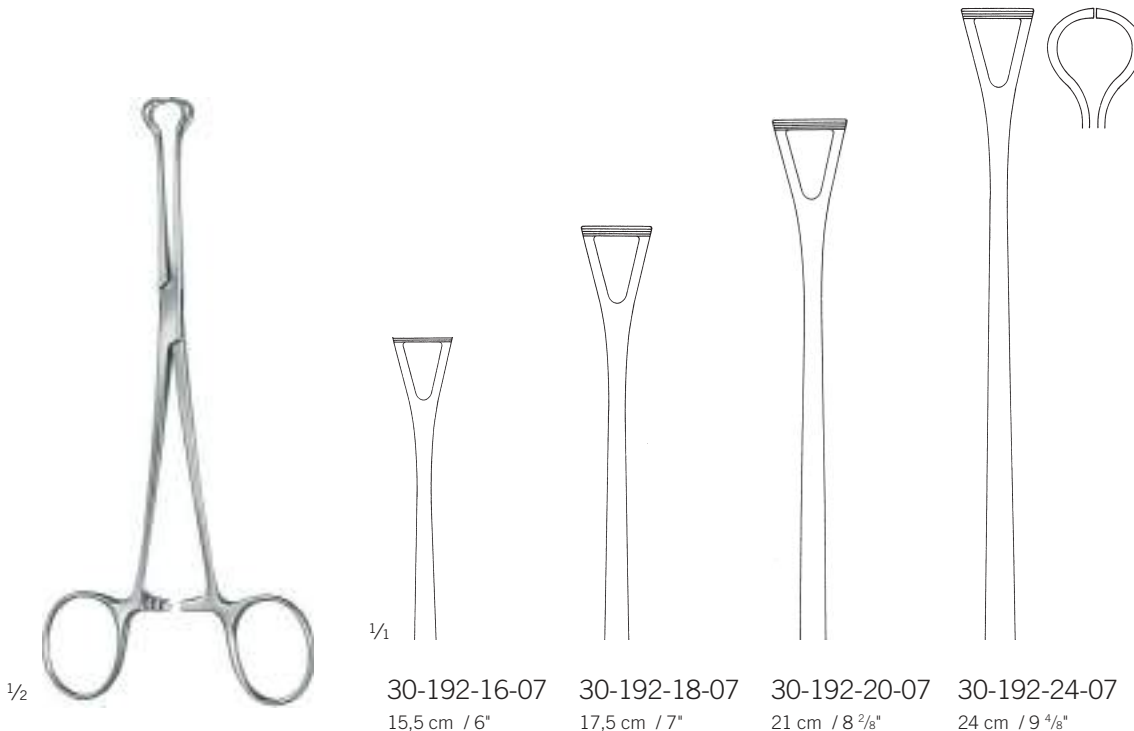

1/2 Babcock
30-192-16-07 -
30-192-24-07

30-192-16-07 15,5 cm / 6"	30-192-18-07 17,5 cm / 7"	30-192-20-07 21 cm / 8 2/8"	30-192-24-07 24 cm / 9 4/8"
------------------------------	------------------------------	--------------------------------	--------------------------------

Atrauma

TC GOLD

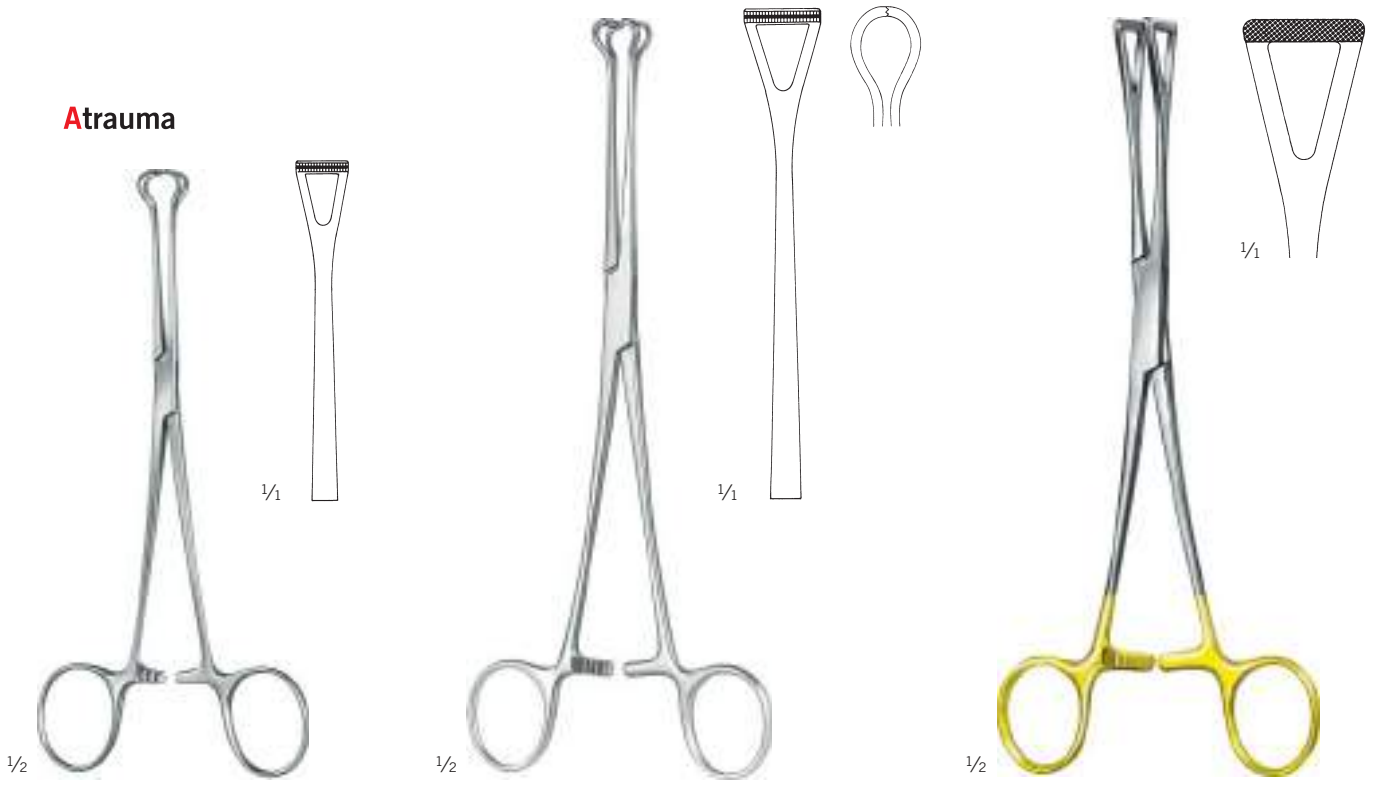

<p>1/2 Atrauma</p> <p>Babcock 30-196-16-07 16 cm / 6 2/8"</p>	<p>1/2 Babcock</p> <p>Babcock 30-196-20-07 21 cm / 8 2/8"</p>	<p>1/2 Duval</p> <p>Duval 30-206-20-07 20,5 cm / 8"</p>
--	--	--

Darm- und Gewebefasszangen, Darmklemmen

Intestinal and Tissue Grasping Forceps, Intestinal Clamps

Pinzas para intestinos y tejidos, Pinzas intestinales

Pinces pour saisir intestins et tissus, Pincers intestinales

Pinze per afferrare intestino e tessuti, Pinze intestinali

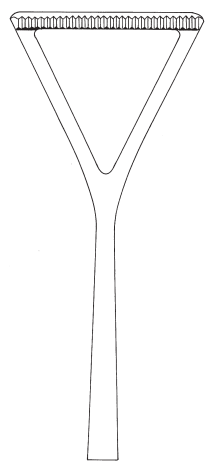
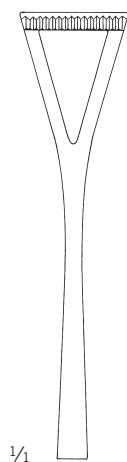

30-210-18-07
18 cm / 7 1/8"

30-212-20-07
20,5 cm / 8 1/8"

30-210-20-07
20,5 cm / 8"

30-212-23-07
23 cm / 9"

Duval
30-210-18-07-
30-212-23-07

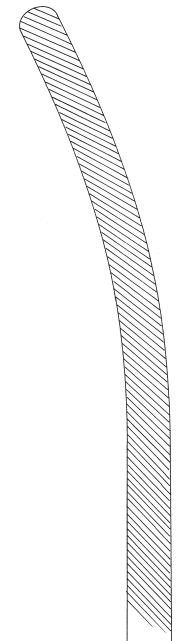
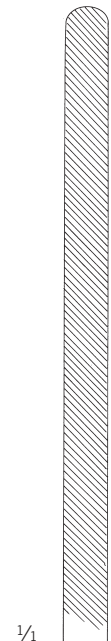

30-274-21-07
21,5 cm / 8 4/8"

30-275-21-07
21 cm / 8 2/8"

30-274-23-07
23,5 cm / 9 2/8"

30-275-23-07
23 cm / 9"

Doyen
30-274-21-07 -
30-275-23-07

Darmklemmen

Intestinal Clamps
Pinzas intestinales
Pincas intestinales
Pinze intestinali

Magen, Darm, Rektum

Stomach, Intestines, Rectum
Estómago, Intestinos, Recto
Estomac, Intestins, Rectum
Stomaco, Intestini, Retto

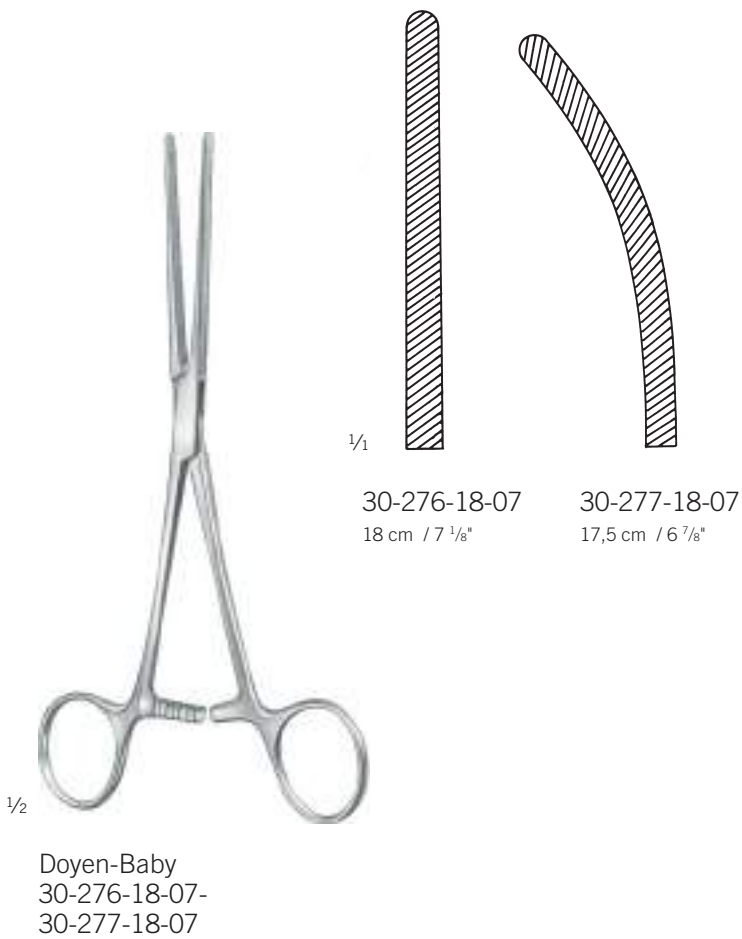
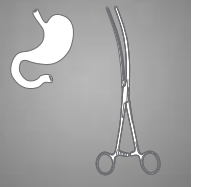

Darmklemmen

Intestinal Clamps

Pinzas intestinales

Pinces intestinales

Pinze intestinali

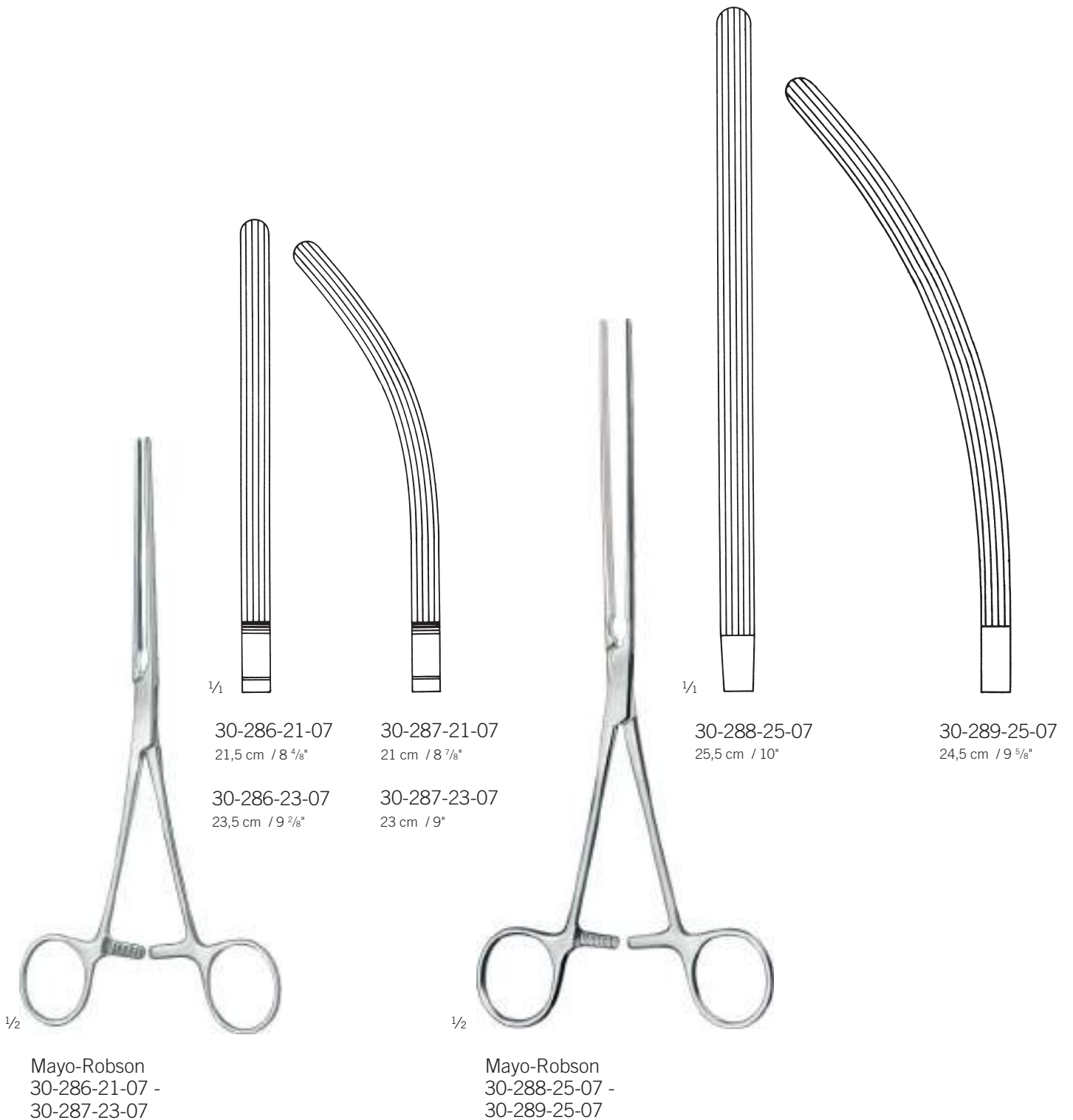

Darmklemmen

Intestinal Clamps
Pinzas intestinales
Pincas intestinales
Pinze intestinali

Magen, Darm, Rektum

Stomach, Intestines, Rectum
Estómago, Intestinos, Recto
Estomac, Intestins, Rectum
Stomaco, Intestini, Retto

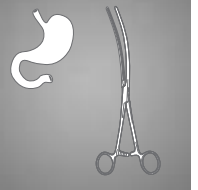

30



1/2

Kocher
30-304-22-07 -
30-304-28-07

1/1



30-304-22-07
22,5 cm / 8 7/8"

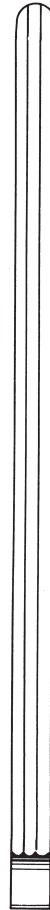

30-304-25-07
25 cm / 9 7/8"

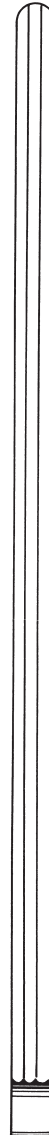

30-304-28-07
28 cm / 11"

Darmklemmen

Intestinal Clamps

Pinzas intestinales

Pinces intestinales

Pinze intestinali



1/2

Kocher
30-305-22-07 -
30-305-28-07



1/1

30-305-22-07
22 cm / 8 5/8"

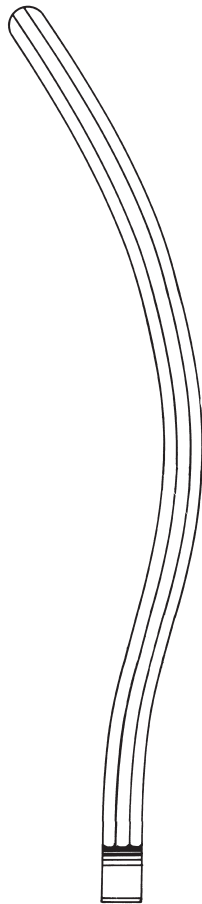

30-305-25-07
24,5 cm / 9 5/8"



30-305-28-07
27,5 cm / 10 5/8"



1/2

Allen
30-398-16-07
16 cm / 6 2/8"

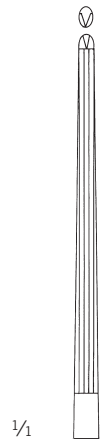

1/1

1:2

Darmquetschklemmen

Intestinal and Pylorus Clamps

Pinzas intestinales para píloro

Ecraseurs pour intestin

Schiacciatori intestinali

Magen, Darm, Rektum

Stomach, Intestines, Rectum

Estómago, Intestinos, Recto

Estomac, Intestins, Rectum

Stomaco, Intestini, Retto

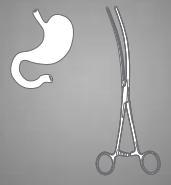

30



1/2

Payr-Baby
30-415-15-07

15 cm / 5 7/8"

mit Stift
with pin
con espiga
avec cheville
con perno



1/1



1/2

Payr
30-419-21-07 -
30-433-35-07

mit Stift
with pin
con espiga
avec cheville
con perno

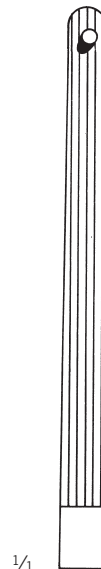

1/1

30-419-21-07
21 cm / 8 2/8"

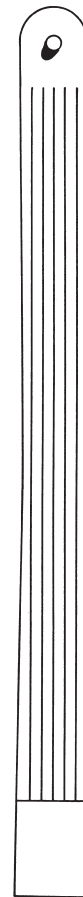

30-425-29-07
29 cm / 11 3/8"

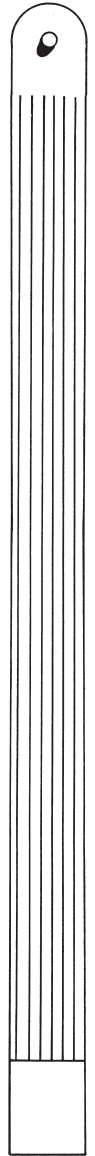

30-433-35-07
34 cm / 13 3/8"

Darm-Anastomosenklemmen

Intestinal Anastomosis Clamps

Clamps para anastomosis intestinales

Pinces pour anastomoses intestinale

Pinze per anastomosi intestinali



1/2

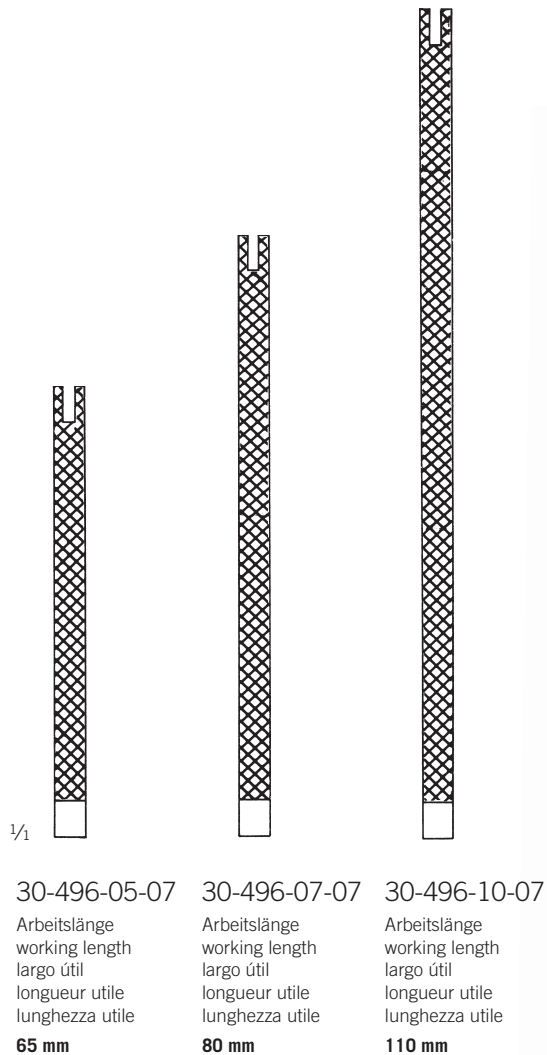

30-496-05-07

Arbeitslänge
working length
largo útil
longueur utile
lunghezza utile

65 mm

30-496-07-07

Arbeitslänge
working length
largo útil
longueur utile
lunghezza utile

80 mm

30-496-10-07

Arbeitslänge
working length
largo útil
longueur utile
lunghezza utile

110 mm



1/2

De Martel-Wolfson

30-496-05-07 -
30-496-10-07

Set bestehend aus 3 Stück einer Länge:

- 2 x Riegel kurz
- 1 x Riegel lang

Set consisting of 3 pieces of one length:

- 2 x lock, short
- 1 x lock, long

Juego formado por 3 piezas de una longitud:

- 2 x pestillo corto
- 1 x pestillo largo

Set composé de 3 pièces d'une longueur:

- 2 x verrou, court
- 1 x verrou, long

Set composto da 3 pezzi di una lunghezza:

- 2 x serrature corte
- 1 x serratura lunga

De Martel-Wolfson

30-497-26-07

27 cm / 10 5/8"

Klemmschließzange

Closing Forceps

Pinza para cerrar grapas

Pinces pour fermer les clamps

Serrapinze



**30-496-05-07 -
30-496-10-07**

Darm-Anastomosenklemmen

Intestinal Anastomosis Clamps
Clamps para anastomosis intestinales
Pincas pour anastomoses intestinale
Pinze per anastomosi intestinali

Magen, Darm, Rektum

Stomach, Intestines, Rectum
Estómago, Intestinos, Recto
Estomac, Intestins, Rectum
Stomaco, Intestini, Retto

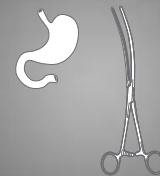

30



De Martel-Wolfson
30-498-08-07

9,5 cm / 3 6/8"

Klemmenhalterung
Clamp Holder
Porta-clamp
Porte-clamps
Portapinze



30-496-05-07 -
30-496-10-07



De Martel-Wolfson
30-498-23-07

23 cm / 9"

Klemmenhalterung
Clamp Holder
Porta-clamp
Porte-clamps
Portapinze



30-496-05-07 -
30-496-10-07



Benson
30-519-16-07

15,5 cm / 6 1/8"

Pylorusspreizer
Pylorus Spreader
Separador para piloro
Ecarteur pour pyloro
Divaricatore piloro

Darm-Anastomosenklemmen

Intestinal Anastomosis Clamps

Clamps para anastomosis intestinales

Pinces pour anastomoses intestinale

Pinze per anastomosi intestinali



30-520-07-07
8,5 cm / 3 ³/₈"

30-520-10-07
11 cm / 4 ³/₈"

1/2

Stone-Watt
30-520-07-07 -
30-520-10-07



1/2

Stone-Watt
30-522-00-07

Klemmschloß
Locking Device
Cierre para clamps intestinales
Serrure pour clamps intestinales
Serratura per pinze intestinali



30-520-07-07 -
30-520-10-07



1/2

Stone-Watt
30-524-15-07
16 cm / 6 ²/₈"

Schließklemme
Closing Forceps
Pinza para cerrar clamps
Pinze pour fermer et porter les champs
Serrapinze e portapinze



30-520-07-07 -
30-520-10-07

Magen- und Darm-Zwillingsklemmen

Stomach and Intestinal Anastomosis Twin Clamps

Pinzas gastro-intestinales gemelas

Pinces stomacales et intestinales jumelées

Pinze gastrointestinali gemelle

Magen, Darm, Rektum

Stomach, Intestines, Rectum

Estómago, Intestinos, Recto

Estomac, Intestins, Rectum

Stomaco, Intestini, Retto

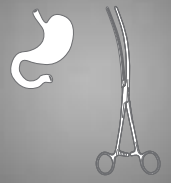

1/2

Lane
30-534-30-07
30 cm / 11 5/8"



1/1

Magen- und Darm-Zwillingsklemmen

Stomach and Intestinal Anastomosis Twin Clamps

Pinzas gastro-intestinales gemelas

Pinces stomacales et intestinales jumelées

Pinze gastrointestinali gemelle

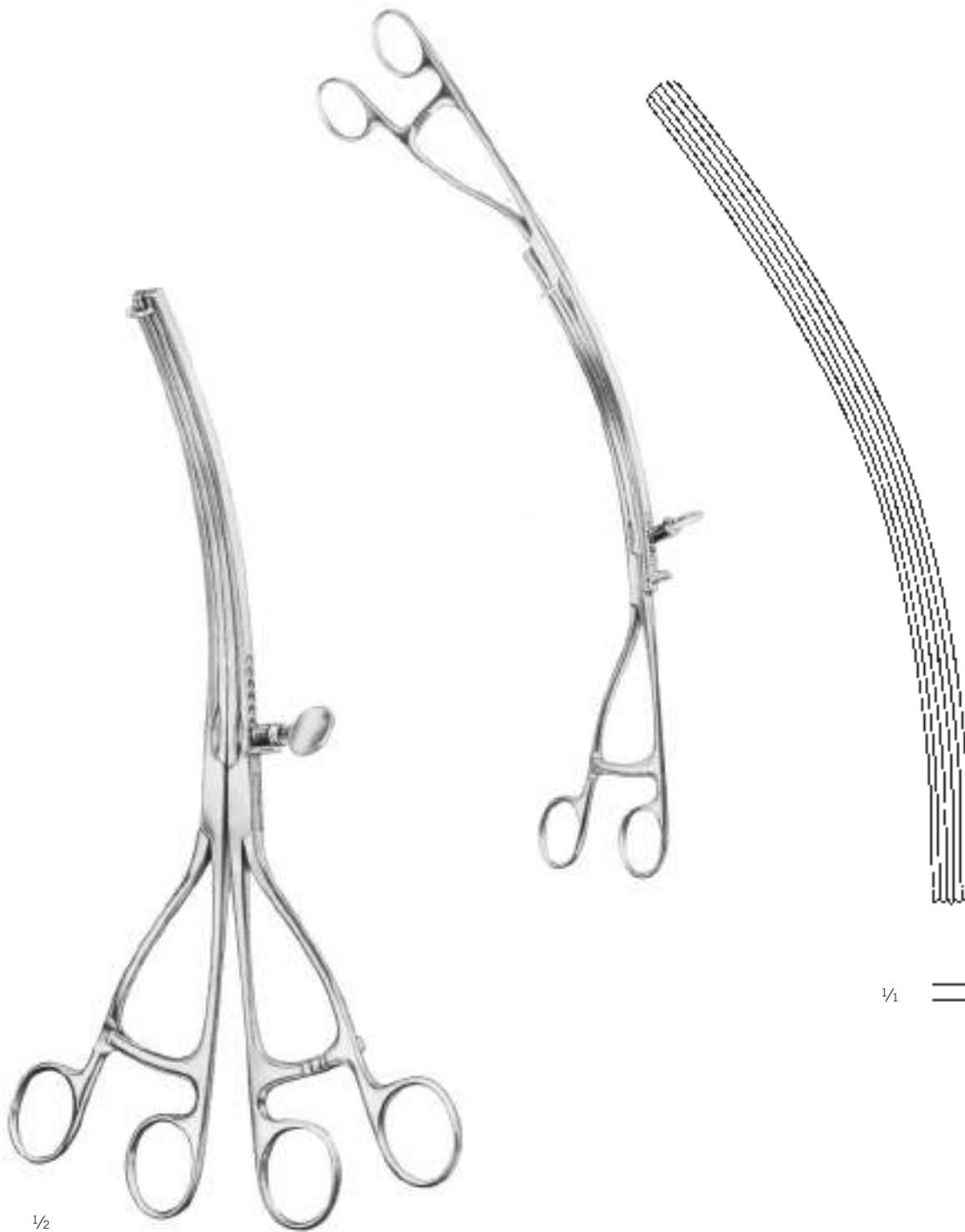

$\frac{1}{2}$

Lane
30-535-30-07
30 cm / 11 $\frac{6}{8}$ "

Organfasszangen

Organ Grasping Forceps
Pinzas para coger órganos
Pinces pour saisir des organes
Pinze per afferrare organi

Magen, Darm, Rektum

Stomach, Intestines, Rectum
Estómago, Intestinos, Recto
Estomac, Intestins, Rectum
Stomaco, Intestini, Retto

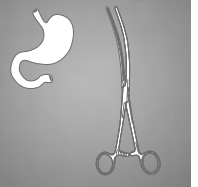

Atrauma

30



1/1

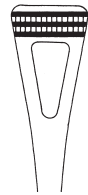

30-540-18-07

18 cm / 7 1/8"

schmal
narrow
estrecho
étroit
stretto

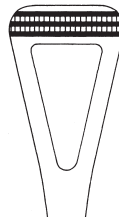

30-540-20-07

20,5 cm / 8 1/8"

mittel
medium
mediano
moyen
medio

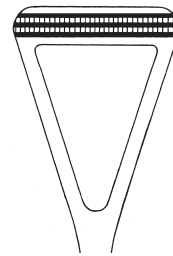

30-540-23-07

23 cm / 9"

breit
wide
ancho
large
largo

1/2

Scheibe
30-540-18-07 -
30-540-23-07

Darmklemmen

Intestinal Clamps
Pinzas intestinales
Pincas intestinales
Pinze intestinali

Atrauma



1/2

Doyen-Baby
30-550-13-07 -
30-550-23-07

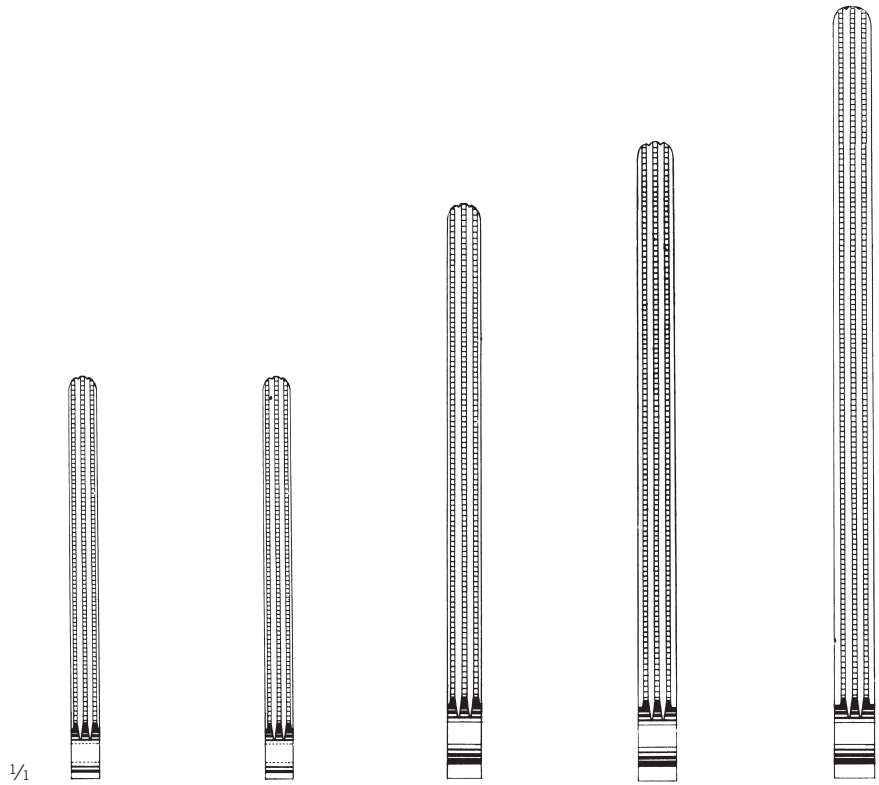

1/1

30-550-13-07	30-550-16-07	30-550-18-07	30-550-21-07	30-550-23-07
14 cm / 5 4/8"	17 cm / 6 6/8"	18,5 cm / 7 2/8"	21,5 cm / 8 4/8"	23,5 cm / 9 2/8"



1/2

Doyen-Baby
30-551-13-07 -
30-551-23-07

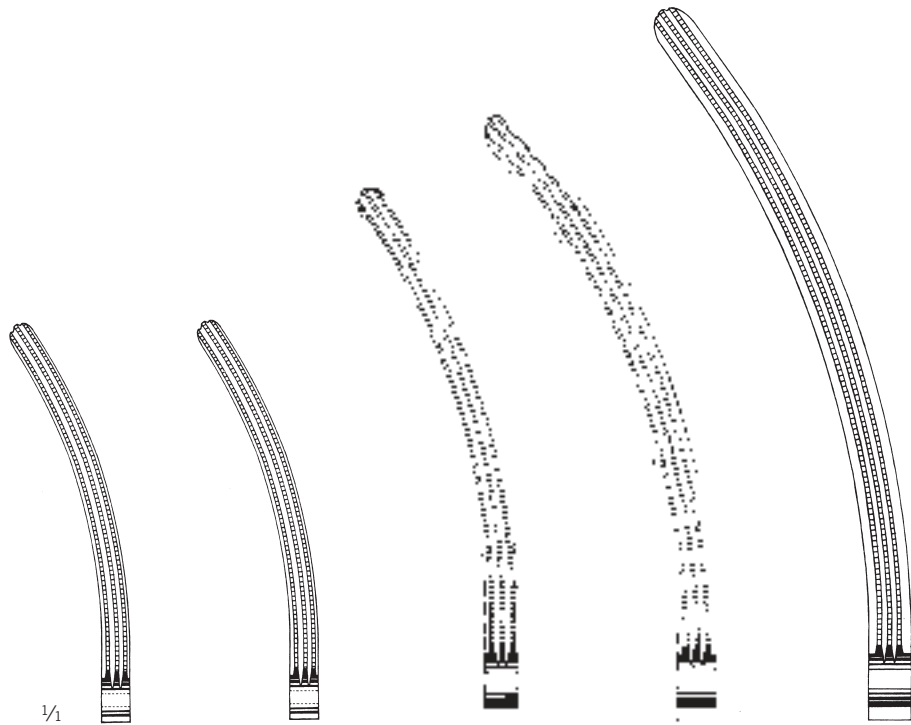

1/1

30-551-13-07	30-551-16-07	30-551-18-07	30-551-21-07	30-551-23-07
13,5 cm / 5 2/8"	17 cm / 6 6/8"	18 cm / 7"	21 cm / 8 2/8"	23 cm / 9"

Darmklemmen

Intestinal Clamps
Pinzas intestinales
Pincas intestinales
Pinze intestinali

Magen, Darm, Rektum

Stomach, Intestines, Rectum
Estómago, Intestinos, Recto
Estomac, Intestins, Rectum
Stomaco, Intestini, Retto

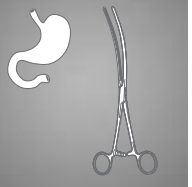

Atrauma

30



1/2

1/1

Mayo-Robson
30-554-25-07
26 cm / 10 2/8"

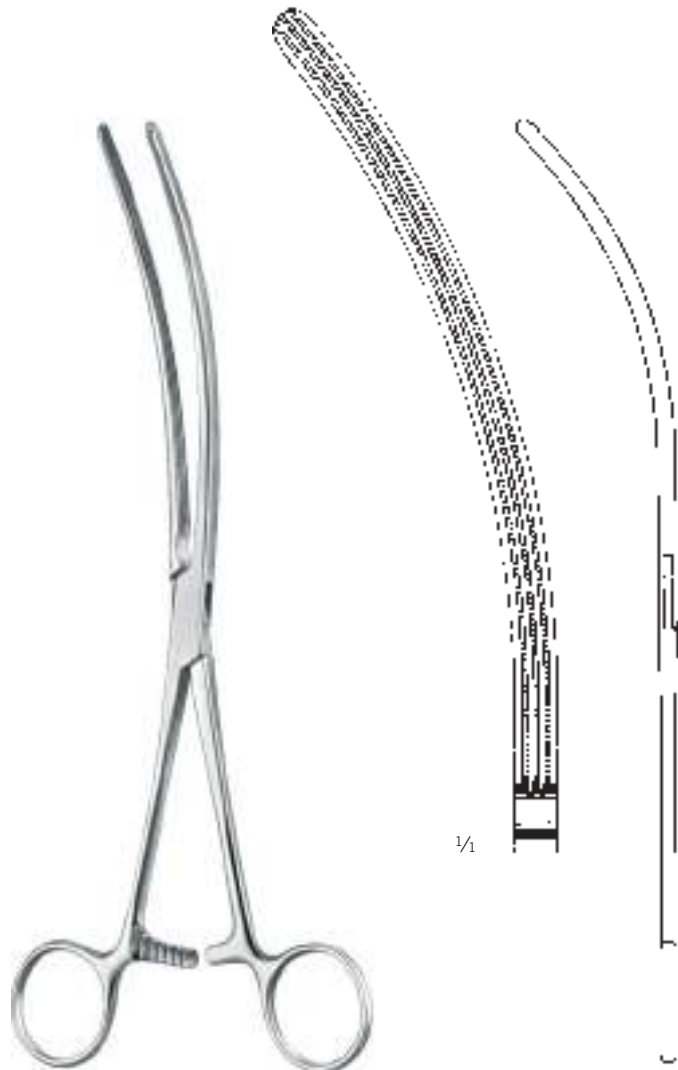

1/2

1/1

Mayo-Robson
30-555-25-07
25 cm / 9 2/8"

Darmklemmen

Intestinal Clamps

Pinzas intestinales

Pinces intestinales

Pinze intestinali

Atrauma



1/2

Kocher
30-560-22-07 -
30-560-28-07

1/1



30-560-22-07
22,5 cm / 8 9/16"

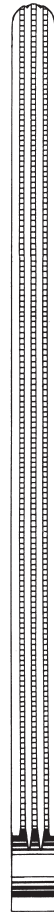

30-560-25-07
25 cm / 9 7/8"

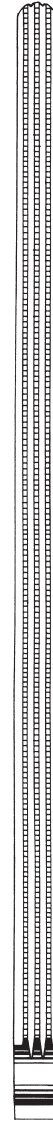

30-560-28-07
28 cm / 11"

Darmklemmen

Intestinal Clamps
Pinzas intestinales
Pincas intestinales
Pinze intestinali

Magen, Darm, Rektum

Stomach, Intestines, Rectum
Estómago, Intestinos, Recto
Estomac, Intestins, Rectum
Stomaco, Intestini, Retto

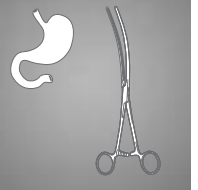

Atrauma

30



1/2

Kocher
30-561-22-07 -
30-561-28-07

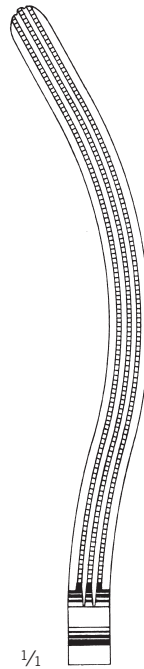
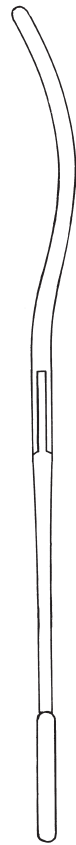

1/1

30-561-22-07
22 cm / 8 5/8"

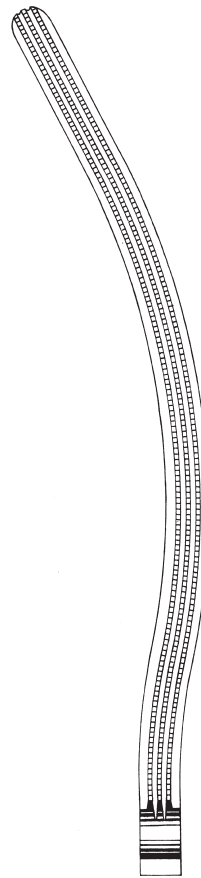

30-561-25-07
24,5 cm / 9 5/8"

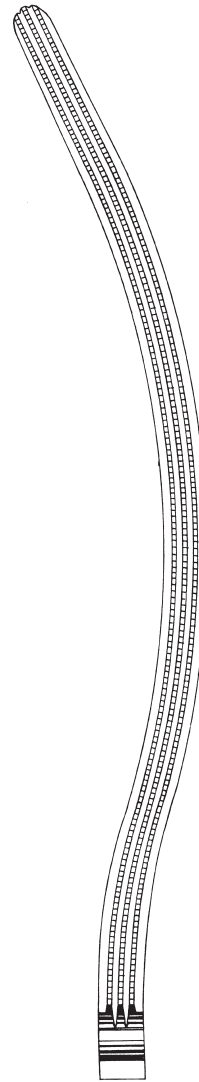

30-561-28-07
27 cm / 10 5/8"

Darmklemmen

Intestinal Clamps

Pinzas intestinales

Pinces intestinales

Pinze intestinali

Atrauma

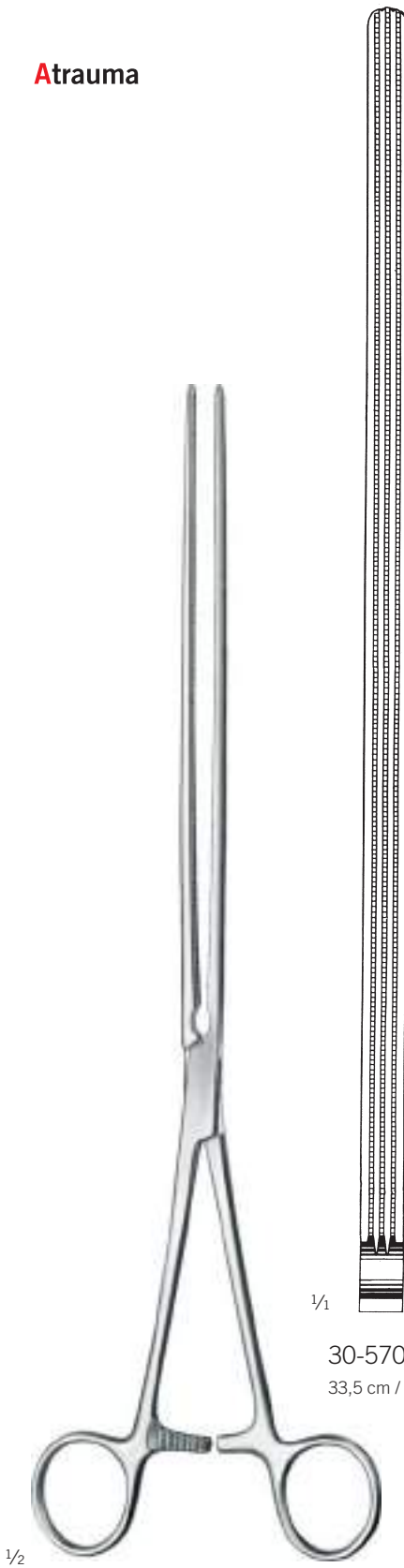

1/2

30-570-33-07
33,5 cm / 13 2/8"

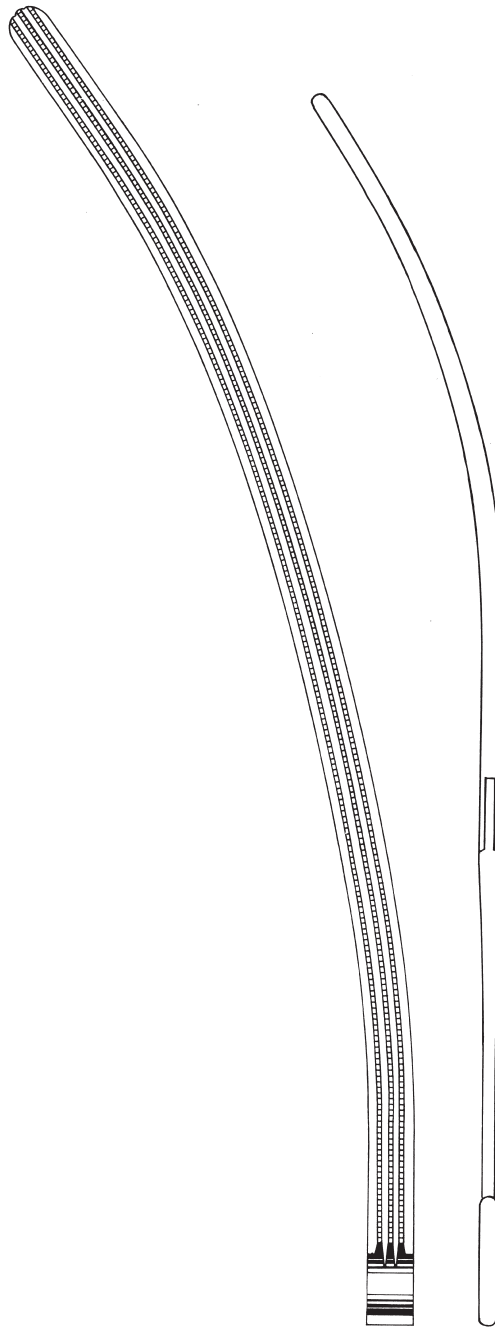

30-571-33-07
32,5 cm / 12 6/8"

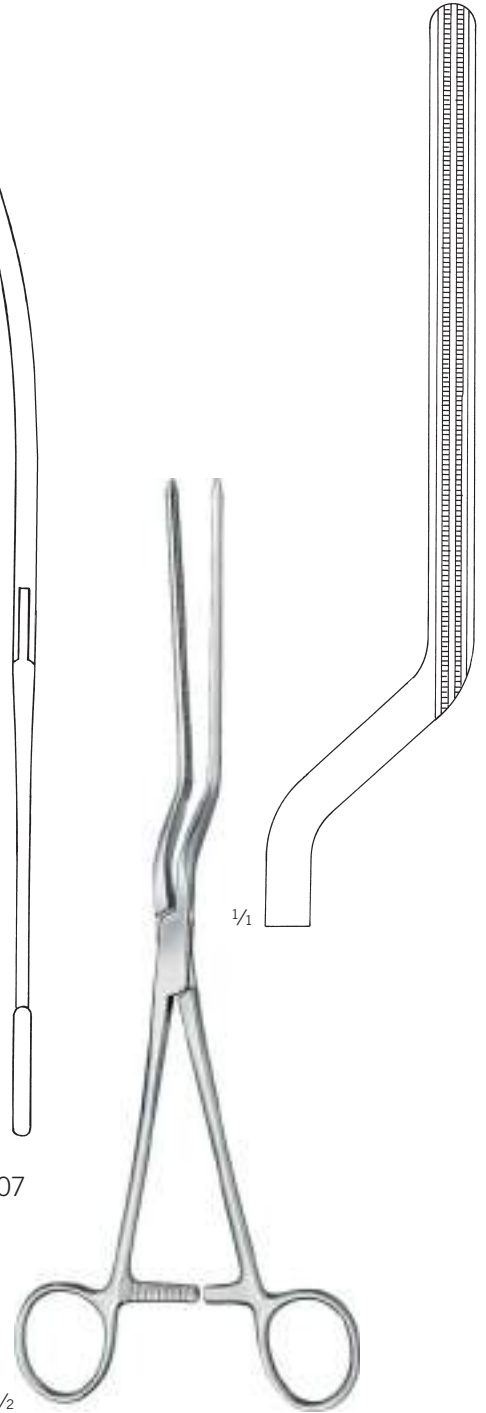

1/2

1/2

Brunner
30-580-24-07
27 cm / 10 6/8"

Scudder
30-570-33-07 -
30-571-33-07

Rektum-Anastomosenklemmen

Sigmoid Anastomosis Forceps
Pinzas para anastomosis rectales
Pinces pour anastomoses rectales
Pinze per anastomosi rettali

Magen, Darm, Rektum

Stomach, Intestines, Rectum
Estómago, Intestinos, Recto
Estomac, Intestins, Rectum
Stomaco, Intestini, Retto

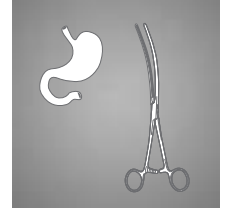

Atrauma

30



1/2

Hayes
30-581-26-07 -
30-581-28-07



1/1

30-581-26-07
27 cm / 10 5/8"

30-581-28-07
28 cm / 11"

Rektum-Anastomosenklemmen

Sigmoid Anastomosis Forceps
Pinzas para anastomosis rectales
Pinces pour anastomoses rectales
Pinze per anastomosi rettali

Atrauma



Rektum-Anastomosenklemmen

Sigmoid Anastomosis Forceps
Pinzas para anastomosis rectales
Pinces pour anastomoses rectales
Pinze per anastomosi rettali

Magen, Darm, Rektum

Stomach, Intestines, Rectum
Estómago, Intestinos, Recto
Estomac, Intestins, Rectum
Stomaco, Intestini, Retto

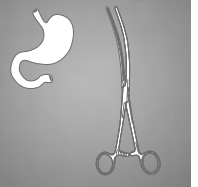

Atrauma

30



Resano
30-587-30-07
28 cm / 11"

Mastdarmspekula, Analspreizer

Rectal Specula, Rectal Spreaders

Espéculos rectales, Separadores rectales

Spéculums rectaux, Ecarteurs rectaux

Specoli rettali, Divaricatori rettali



105 x 23-28 mm

1/2

Czerny
30-610-21-07
22,5 cm / 8 7/8"



70 x 15 mm

1/2

Sims
30-613-15-01
15,5 cm / 6 1/8"



70 x 15 mm

1/2

Sims
30-615-15-01
15,5 cm / 6 1/8"



80 x 25 mm

1/2

Pratt
30-624-20-07
20 cm / 7 7/8"



Ø 22 mm

1/2

Ives-Fansler
30-641-15-07
Analspreizer
Rectal Spreaders
Separadores rectales
Ecarteurs rectaux
Divaricatori rettali

Arbeitslänge
working length
largo útil
longueur utile
lunghezza utile
80 mm

Analspreizer

Rectal Spreaders
Separadores rectales
Ecarteurs rectaux
Divaricatori rettali

Magen, Darm, Rektum

Stomach, Intestines, Rectum
Estómago, Intestinos, Recto
Estomac, Intestins, Rectum
Stomaco, Intestini, Retto

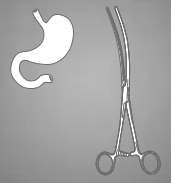

30



1/2



1/2

Alan-Parks
30-647-00-07 -
30-647-95-98

30-647-00-07

14 cm / 5 4/8"
ohne Kaltlichtaufsatz
without F.O. light carrier
sin portador de luz fría
sans support lumière froide
senza supporto per luce fredda

30-647-50-07

14 cm / 5 4/8"
mit Kaltlichtaufsatz
with F.O. light carrier
con portador de luz fría
avec support lumière froide
con supporto per luce fredda



1/2

30-647-51-01

Kaltlichtaufsatz
F.O. light carrier
Portador de luz fría
Support lumière froide
Supporto per luce fredda



30-647-94-98

Paar Seitenvalven lang, Nutzlänge 95 mm
Pair of lateral blades, long, useful length 95 mm
Un par de valvas laterales, largas, longitud útil 95 mm
Paire de valves latérales, longues, longueur utile 95 mm
Coppia di valve laterali lunghe, lungh. utile 95 mm

30-647-95-98

Mittelvalve, Nutzlänge 95 mm
Central Blade, useful length 95 mm
Valva central, longitud útil 95 mm
Valve centrale, longueur utile 95 mm
Valva centrale, lungh. utile 95 mm

30-647-92-98

Flügelmutter
Wing nut
Tuerca de mariposal
Ecroû à oreilles
Madrevite ad alette

30-647-93-98

Paar Seitenvalven kurz, Nutzlänge 75 mm
Pair of lateral blades, short, useful length 75 mm
Un par de valvas laterales, cortas, longitud útil 75 mm
Paire de valves latérales, courtes, longueur utile 75 mm
Coppia di valve laterali corte, lungh. utile 75 mm

Sphinkteroskope, Hämorrhoidal-Ligator

Sphincteroscopes, Hemorrhoidal Ligator
 Esfincteroscopios, Ligador para hemorroides
 Sphinctérosopes, Ligateur pour h morroides
 Sfincteroscopi, Legatore emorroidale



30-649-01-07

Ø 21 mm

Arbeitslänge
 working length
 largo útil
 longueur utile
 lunghezza utile

50 mm

30-649-02-07

Ø 27 mm

Arbeitslänge
 working length
 largo útil
 longueur utile
 lunghezza utile

50 mm

Kelly

30-649-01-07 -
 30-649-02-07



30-723-26-07

Ladekonus
 Loading Cone
 Cono de carga
 Cône de charge
 Cono per caricare

Rudd

30-723-10-04 -
 30-723-27-07



30-723-10-04

Ligatur-Gummiringe
 Rubber Rings
 Anillos de goma
 Anneaux en caoutchouc
 Anelli di gomma

Packung mit 100 Stück
 package of 100 pieces
 paquete con 100 piezas
 paquet avec 100 pièces
 confezione di 100 pezzi



30-723-27-07



30-723-27-07

27,5 cm / 10 7/8"

komplett mit Ladekonus
 complete with loading cone
 completo con cono de carga
 complet avec cône de charge
 completo con cono per caricare

Hämorrhoidal-Faßzange, Rektum-Biopsiefasszangen Magen, Darm, Rektum

Hemorrhoidal Ligator, Rectal Biopsy Forceps

Ligador para hemorroides, Pinzas para biopsia rectal

Ligateur pour hémorroïdes, Pincés pour biopsie rectale

Legatore emorroidale, Pinze per biopsia rettale

Stomach, Intestines, Rectum

Estómago, Intestinos, Recto

Estomac, Intestins, Rectum

Stomaco, Intestini, Retto

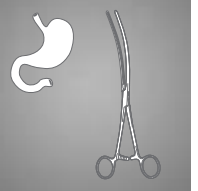

30

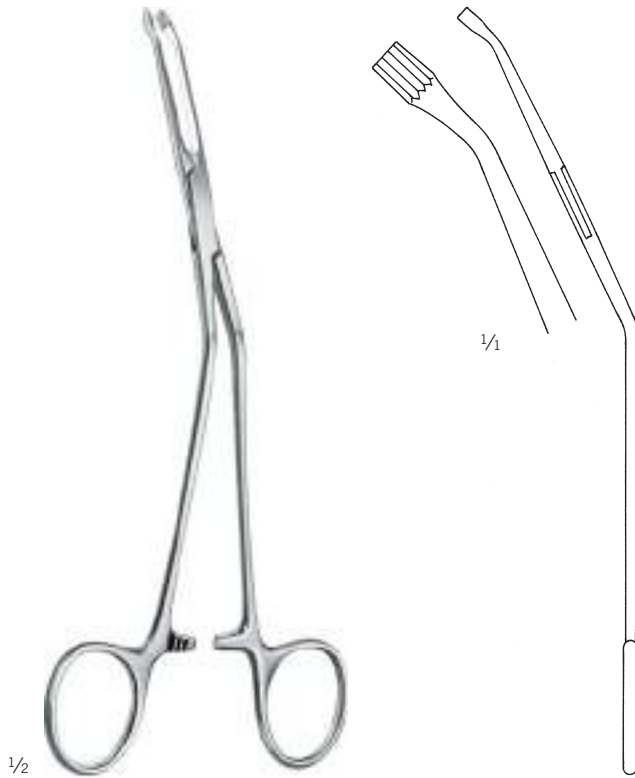

McGinvey
30-724-19-07
19,5 cm / 7 5/8"

Atrauma

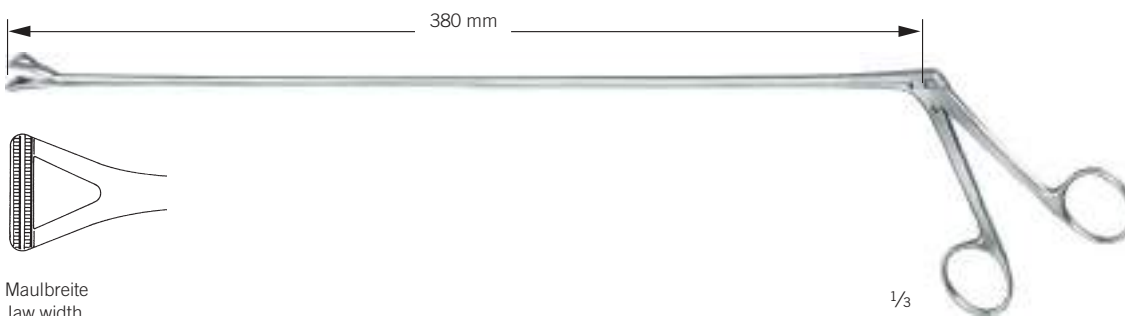

Maulbreite
Jaw width
Anchura de la boca
Lageur de mors
Larghezza della bocca
15 mm

30-741-38-07
38 cm / 15"

Urologie
Urology
Urología
Urologie
Urologia

31

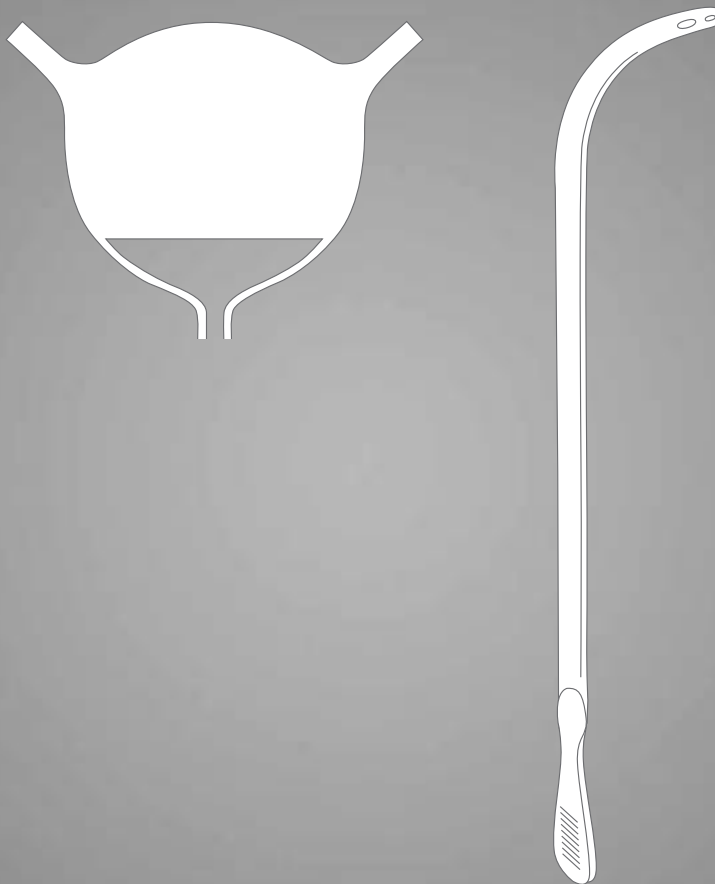

Nierensteinzangen

Kidney Stone Forceps

Pinzas para cálculos renales

Pinces pour les calculs du bassinet

Pinze per calcoli renali



1/2

Randall
31-101-23-07 -
31-107-22-07

1/1

Fig. 1
31-101-23-07
23 cm / 9"



Fig. 2
31-103-22-07
21 cm / 8 2/8"



Fig. 3
31-105-22-07
19 cm / 7 4/8"



Fig. 4
31-107-22-07
18,5 cm / 7 2/8"



1/2

Heiming
31-113-16-07 -
31-113-17-07

für Kinder
for children
para niños
pour enfants
per bambini

1/1

Fig. 1
31-113-16-07
16 cm / 6 2/8"

Fig. 2
31-113-17-07
17 cm / 6 6/8"

Gallenkanaldilatatoren

Gall Duct Dilators

Dilatadores para conducto biliar

Dilatateurs pour les voies biliaires

Dilatatori per condotti biliari

Urologie

Urology

Urología

Urologie

Urologia

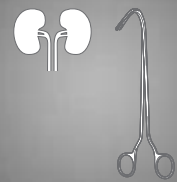

1/1

Fig. 1	Fig. 2	Fig. 3	Fig. 4
Ø 1,0 mm	Ø 2,0 mm	Ø 3,0 mm	Ø 4,0 mm
31-170-01-01	31-170-02-01	31-170-03-01	31-170-04-01

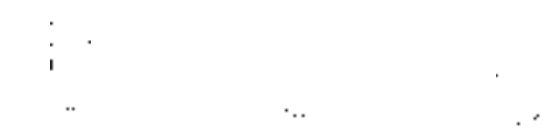

Fig. 5	Fig. 6	Fig. 7
Ø 5,0 mm	Ø 6,0 mm	Ø 7,0 mm
31-170-05-01	31-170-06-01	31-170-07-01

Fig. 8	Fig. 9	Fig. 10
Ø 8,0 mm	Ø 9,0 mm	Ø 10 mm
31-170-08-01	31-170-09-01	31-170-10-01

Fig. 11	Fig. 12	Fig. 13
Ø 11 mm	Ø 12 mm	Ø 13 mm
31-170-11-01	31-170-12-01	31-170-13-01



1/2

Bakes

31-170-01-01 -

31-170-13-01

32 cm / 12 5/8"

biegsamer Schaft

malleable shaft

vástago maleable

tige malléable

gambo malleabile

Gallensteinzangen

Gall Stone Forceps
Pinzas para cálculos biliares
Pinces pour calculs biliaires
Pinze per calcoli biliari



1/1

31-204-20-07
21 cm / 8 2/8"

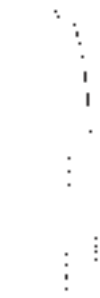

31-205-20-07
20,5 cm / 8 1/8"

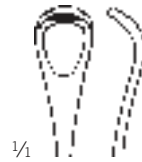

1/1



1/1



1/2

Blake
31-204-20-07 -
31-205-20-07



1/2

Mayo-Blake
31-214-20-07
21 cm / 8 2/8"



1/2

Mayo-Blake
31-215-20-07
21 cm / 8 2/8"

Gallensteinzangen

Gall Stone Forceps

Pinzas para cálculos biliares

Pinces pour calculs biliaires

Pinze per calcoli biliari

Urologie

Urology

Urología

Urologie

Urologia



1/2

Mixer
31-217-22-07
22 cm / 8 5/8"



1/2

Desjardins
31-223-23-07 -
31-225-23-07
23 cm / 9"

1/4



Fig. 1
31-223-23-07



Fig. 2
31-225-23-07



1/2

Desjardins
31-226-25-07
22,5 cm / 8 7/8"

1/4

Gallensteinlöffel

Gall Stone Scoops

Cucharas para cálculos biliares

Curettes pour calculs biliaires

Pinze per calcoli biliari



Fig. 000	Fig. 00	Fig. 0	Fig. 1
2,7 mm	3,4 mm	4,3 mm	5,5 mm
31-340-01-07	31-340-02-07	31-340-03-07	31-340-04-07

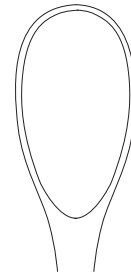

Fig. 2	Fig. 3	Fig. 4	Fig. 5
6,6 mm	8 mm	11 mm	15 mm
31-340-05-07	31-340-06-07	31-340-07-07	31-340-08-07

1/2

Luer-Körte
31-340-01-07 -
31-340-08-07

32 cm / 12 5/8"

biegsamer Schaft, stumpf
malleable shaft, blunt
vástago maleable, romo
tige malléable, mousse
gambo malleabile, smusso

Prostatahaken

Prostatic Retractors
Separadores para próstata
Ecarteurs prostatiques
Divaricatori prostatici

Urologie

Urology
Urología
Urologie
Urologia

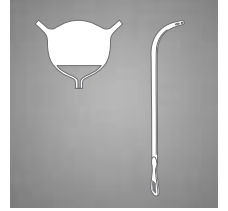

1/2

Young
31-401-21-07
22 cm / 8 5/8"



1/2

Young
31-405-21-07
22 cm / 8 4/8"



1/2

Young
31-407-22-07
23 cm / 9"

Kapsel­fass­zangen

Capsule Forceps

Pinzas capsulares

Pinces pour saisir les capsules

Pinze per afferrare capsule

Atrauma



Millin
31-451-24-07
24,5 cm / 9 5/8"

Atrauma



Millin
31-453-24-07
22,5 cm / 8 7/8"



Millin
31-461-23-07
24,5 cm / 9 5/8"

Kapsel­f­ass­z­ang­e, Faden­f­üh­rungs­z­ang­e

Capsule Forceps, Ligature Carrying Forceps
Pinzas capsulares, Pinza porta ligaduras
Pincés pour saisir les capsules, Pince porte-fil
Pinze per afferrare capsule, Pinza porta-filo

Urologie

Urology
Urología
Urologie
Urologia

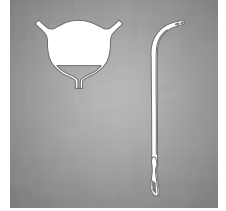

1/2
Millin
31-463-23-07
22 cm / 8 5/8"



1/2
Millin
31-465-24-07
24 cm / 9 4/8"

Blasenhalsperrer, Blasenwundsperrer

Bladder Neck Spreader, Bladder Retractors

Dilatador para el cuello vesical, Separadores vesicales

Ecarteur pour le col de la vessie, Ecarteurs vésicaux

Divaricatore del collo vescicale/Divaricatore vescicale



1/2

Millin
31-475-00-07
29,5 cm / 11 5/8"



70 mm



1/2

Judd-Masson
31-510-00-07



120 mm

Blasenwundsperrer

Bladder Retractors
Separadores vesicales
Ecarteurs vésicaux
Divaricatore vescicale

Urologie

Urology
Urología
Urologie
Urologia

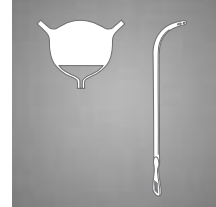

31



57 x 25 mm
31-512-90-98

Seitenvalven
Lateral Blades
Valvas laterales
Valves laterales
Valve laterali



80 x 25 mm
31-512-91-98

Seitenvalven
Lateral Blades
Valvas laterales
Valves laterales
Valve laterali

120 x 45 mm
31-512-92-98

Mittelvalve, **ohne** Kaltlichtaufsatz
Central Blade, **without** F.O. carrier
Valva central, **sin** portador de luz fría
Valve centrale, **sans** support lumière froide
Valva centrale, **senza** supporto per luce fredda

Millin

31-512-00-07

komplett, mit je 2 Seitenvalven
57 x 25 mm und 80 x 25 mm, sowie
einer 1 Mittelvalve 120 x 45 mm,
ohne Kaltlichtaufsatz

complete, with 2 pairs of lateral
blades 57 x 25 mm and 80 x 25 mm,
and 1 central blade 120 x 45 mm,
without F.O. carrier

completo, con 2 pares de valvas lat-
erales 57 x 25 mm y 80 x 25 mm y
una valva central 120 x 45 mm,
sin portador de luz fría

complet, avec 2 paires de valvas
latérales 57 x 25 mm et 80 x 25 mm
et 1 valve centrale 120 x 45 mm,
sans support lumière froide

completo, con 2 paia di valve laterali
57 x 25 mm e 80 x 25 mm in più 1
valva centrale 120 x 45 mm,
senza supporto per luce fredda

Harnröhrenbougies

Urethral Sounds

Bujías uretrales

Bougies urétrales

Candelette dilatatrici

1/1



Charrière	Van Buren
8	31-599-08-07
10	31-599-10-07
12	31-599-12-07
14	31-599-14-07
16	31-599-16-07
18	31-599-18-07
20	31-599-20-07
22	31-599-22-07
24	31-599-24-07
26	31-599-26-07
28	31-599-28-07
30	31-599-30-07
32	31-599-32-07
34	31-599-34-07
36	31-599-36-07

1/2

Van Buren
31-599-00-07 -
31-599-36-07
27 cm / 10 5/8"

31-599-00-07
Satz komplett, 8 - 36 Charrière
complete set, 8 - 36 Charrière
juego completo, 8 - 36 Charrière
jeu complet, 8 - 36 Charrière
set completo, 8 - 36 Charrière

1/1 +



Charrière	Guyon
10	31-607-10-07
11	31-607-11-07
12	31-607-12-07
13	31-607-13-07
14	31-607-14-07
15	31-607-15-07
16	31-607-16-07
17	31-607-17-07
18	31-607-18-07
19	31-607-19-07
20	31-607-20-07
21	31-607-21-07
22	31-607-22-07
23	31-607-23-07
24	31-607-24-07
25	31-607-25-07
26	31-607-26-07
27	31-607-27-07
28	31-607-28-07
29	31-607-29-07
30	31-607-30-07

1/2

Guyon
31-607-10-07 -
31-607-30-07
26,5 cm / 10 3/8"

Gleitsonde, Harnröhrenbougies, Katheter

Filiform Bougie, Urethral Sounds, Catheters

Sonda filiforme, Bujías uretrales, Sondas

Bougie conductrice, Bougies urétrales, Sondes

Candeletta filiforme, Candelette dilatatrici, Sonde

Urologie

Urology

Urología

Urologie

Urologia

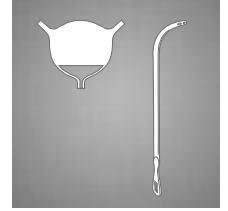

Charrière	
3	31-610-13-04
4	31-610-14-04
5	31-610-15-04
6	31-610-16-04

1/2

Filiform

31-610-13-04 -
31-610-16-04

mit Schraubgewinde-Ansatz

with screw thread

con rosa de tornillo

avec embout fileté

con attacco filettato

Charrière	
13	31-721-12-01
15	31-721-14-01



1/2

31-721-12-01 -
31-721-14-01

15 cm / 5 7/8"

Metallkatheter für Frauen

Metal Catheters, female

Sondas metálicas, femeninas

Sondes métalliques, pour femmes

Sonde metalliche, per donne

Urethrotom

Urethrotome

Uretrótopo

Urétrótome

Uretrotomi



1/2

31-740-90-98

3 Ansätze allein
3 tips only
3 puntas suelta
3 embouts seul
3 punte solo



Otis

31-740-00-07

komplett im Holzetui, mit Dilator, 2 Messern und 3 Ansätzen
complete in wooden case, with dilator, 2 knives and 3 tips
completo en caja de madera, con dilatador, 2 cuchillos y 3 puntas
complet en boîte de bois, avec dilataieur, 2 lames et 3 embouts
completo in contenitore di legno, con dilatatore, 2 bisturi e 3 punte



1/2



1/2

Otis

31-745-00-07

Ersatzmesser
Spare Blade
Cuchillo de repuesto
Couteau de rechange
Lama di ricambio



31-740-00-07

Urethrographie- u. Circumcisions-Instrumente

Urethrography- and Circumcision Instruments
Instrumentos para uretrografía y circuncisión
Instruments pour uréthrographie et circoncision
Strumenti per uretrografia e circoncisione

Urologie

Urology
Urología
Urologie
Urologia

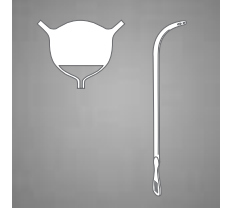

31



1/2

Knutson

31-760-00-07

Urethrographieinstrument
Urethrography Instrument
Instrumento para uretrografía
Instrument pour uréthrographie
Strumento per uretrografia



1/2

Knutson-Koch

31-763-00-04

Konus, allein
Cone, only
Cono, suelto
Cône, seul
Cono, solo



31-760-00-07



1/2

31-765-08-07 -
31-765-32-07

Circumcisionsgerät
Circumcision Instrument
Instrumento para circuncisión
Instrument de circoncision
Strumento per circoncisione

	∅
31-765-08-07	8 mm
31-765-11-07	11 mm
31-765-13-07	13 mm
31-765-16-07	16 mm
31-765-21-07	21 mm
31-765-26-07	26 mm
31-765-32-07	32 mm



1/2

Mogen

31-766-00-07

7,5 cm / 3 "

Beschneidungsinstrument
Circumcision Instrument
Instrumento para circuncisión
Instrument de circoncision
Strumento per circoncisione

Fremdkörperzangen

Foreign Body Forceps
 Pinzas para cuerpos extraños
 Pincès pour corps étrangers
 Pinze per corpi estranei

1/1

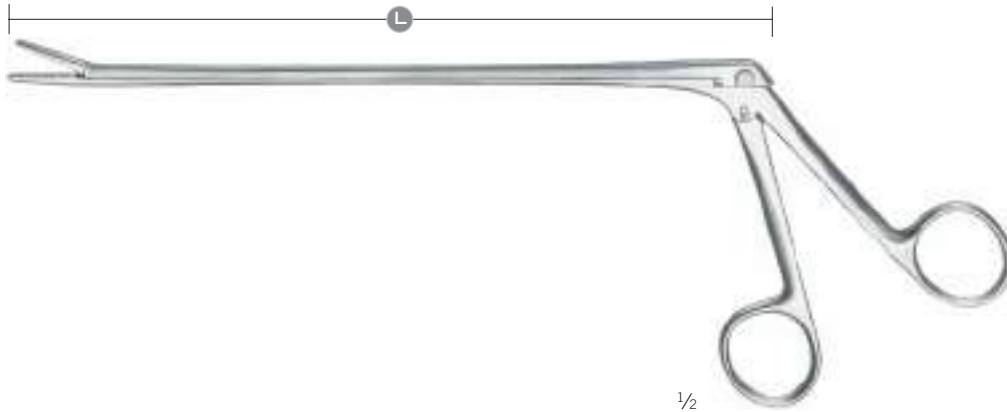

Mathieu
 31-811-20-07

Schaftlänge
 shaft length
 longitud del vástago
 longueur de la tige
 lunghezza dell'asta
200 mm

Mathieu
 31-811-28-07

Schaftlänge
 shaft length
 longitud del vástago
 longueur de la tige
 lunghezza dell'asta
300 mm

1/1

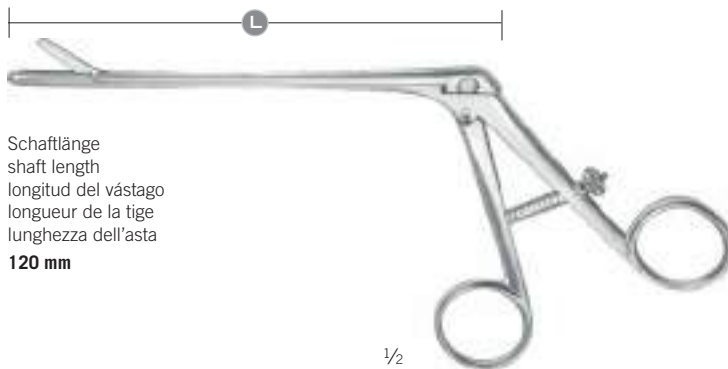

Schaftlänge
 shaft length
 longitud del vástago
 longueur de la tige
 lunghezza dell'asta
120 mm

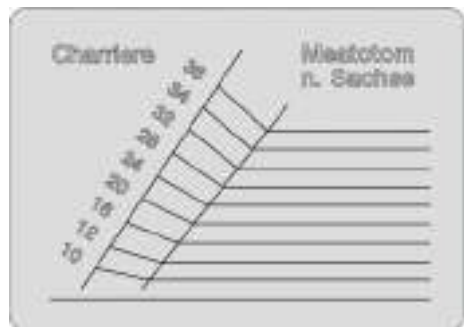

1/2

Sachse
 31-817-12-07

Meatotom
 Meatotome
 Meatótomo
 Méatotome
 Meatotomo

Sachse
 31-817-00-01

Messlehre
 Gauge
 Calibre
 Calibre
 Calibro



31-817-12-07

Penisklemmen

Penis Clamps
Clamps para pene
Pinces pour pénis
Serrapene

Urologie

Urology
Urología
Urologie
Urologia

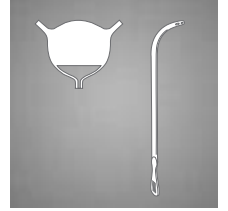

31



1/2

Stockmann
31-875-08-01
8 cm / 3 1/8"



1/2

Strauss
31-881-11-01
11 cm / 4 3/8"

31-881-90-98

1 Paar Schläuche allein
1 pair of flexible tubes only
1 par de mangueras individuales
1 paire de tubes flexibles, seuls
1 coppia di tubi flessibili singoli

Gynäkologie
Gynecology
Ginecología
Gynécologie
Ginecologia

32

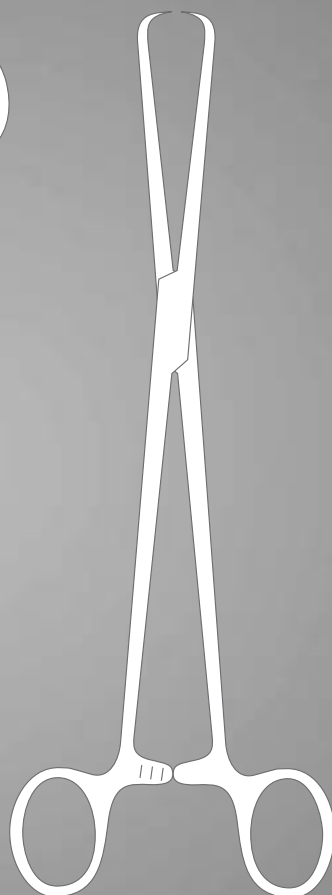
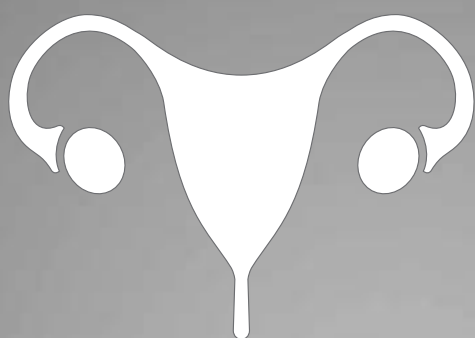

Vaginalspekula

Vaginal Specula
Espéculos vaginales
Spéculums vaginaux
Specoli vaginali



1/2

Cusco

32-110-01-01	75 x 32 mm
32-110-02-01	85 x 37 mm
32-110-03-01	100 x 35 mm



1/2

Cusco

32-112-01-01	75 x 18 mm
--------------	------------



1/2

Cusco

32-114-01-01	90 x 22 mm
32-114-02-01	100 x 25 mm
32-114-03-01	105 x 27 mm



1/2

Cusco

32-116-01-01	75 x 34 mm
32-116-02-01	85 x 37 mm
32-116-03-01	100 x 37 mm



1/2

Collin

32-120-01-01	85 x 30 mm
32-120-02-01	100 x 35 mm
32-120-03-01	110 x 40 mm

Vaginalspekula

Vaginal Specula
Espéculos vaginales
Spéculums vaginaux
Specoli vaginali

Gynäkologie

Gynecology
Ginecología
Gynécologie
Ginecologia

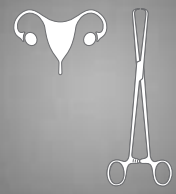

32



1/2

Trelat

32-126-01-01	85 x 33 mm
32-126-02-01	95 x 35 mm
32-126-03-01	115 x 43 mm



1/2

Pederson

32-128-01-01	75 x 13 mm
32-128-02-01	100 x 24 mm
32-128-03-01	120 x 26 mm



1/2

Grave

32-130-01-01	75 x 20 mm
32-130-02-01	95 x 35 mm
32-130-03-01	115 x 35 mm



1/2

Semm

32-132-01-01	100 x 20-25 mm
32-132-02-01	100 x 27-35 mm



1/2

Guttman

32-133-01-07	90 x 35 mm
--------------	------------

Vaginalspekula, Scheidenhalter

Vaginal Specula, Vaginal Retractors
Espéculos vaginales, Valvas vaginales
Spéculums vaginaux, Valves vaginales
Specoli vaginali, Valve vaginali



1/2

Sims

32-160-01-01	65 x 25 mm / 70 x 30 mm
32-160-02-01	70 x 30 mm / 80 x 35 mm
32-160-03-01	85 x 35 mm / 90 x 40 mm



1/2

Jackson

32-165-01-07	75 x 38 mm
32-165-02-07	90 x 38 mm
32-165-03-07	100 x 38 mm

Vaginalspekula, Scheidenhalter

Vaginal Specula, Vaginal Retractors
 Espéculos vaginales, Valvas vaginales
 Spéculums vaginaux, Valves vaginales
 Specoli vaginali, Valve vaginali

Gynäkologie

Gynecology
 Ginecología
 Gynécologie
 Ginecologia

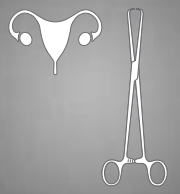

1/2

Kristeller

32-182-01-01	Fig. 1	70 x 27 mm
32-182-02-01	Fig. 2	80 x 30 mm
32-182-03-01	Fig. 3	90 x 36 mm



1/2

Kristeller

32-183-01-01	Fig. 1	75 x 23 mm
32-183-02-01	Fig. 2	85 x 26 mm
32-183-03-01	Fig. 3	100 x 32 mm



1/2

Kristeller

32-185-01-01	Fig. 1	(32-182-01-01 & 32-183-01-01)
32-185-02-01	Fig. 2	(32-182-02-01 & 32-183-02-01)
32-185-03-01	Fig. 3	(32-182-03-01 & 32-183-03-01)

Vaginalspekula, Scheidenhalter

Vaginal Specula, Vaginal Retractors
 Espéculos vaginales, Valvas vaginales
 Spéculums vaginaux, Valves vaginales
 Specoli vaginali, Valve vaginali



½

Kristeller

32-190-01-01	Fig. 1	105 x 18 mm
32-190-02-01	Fig. 2	110 x 21 mm



½

Kristeller

32-191-01-01	Fig. 1	110 x 14 mm
32-191-02-01	Fig. 2	115 x 17 mm



½

Kristeller

32-195-01-01	Fig. 1	(32-190-01-01 & 32-191-01-01)
32-195-02-01	Fig. 2	(32-190-02-01 & 32-191-02-01)

Vaginalspekula, Scheidenhalter

Vaginal Specula, Vaginal Retractors
 Espéculos vaginales, Valvas vaginales
 Spéculums vaginaux, Valves vaginales
 Specoli vaginali, Valve vaginali

Gynäkologie

Gynecology
 Ginecología
 Gynécologie
 Ginecologia

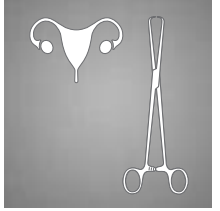

flaches Spekulum
 flat speculum
 espéculo plano
 spéculum plat
 specolo piatto



1/2

Kristeller

32-196-01-01	Fig. 1	105 x 26 mm
32-196-02-01	Fig. 2	105 x 28 mm
32-196-03-01	Fig. 3	105 x 33 mm



1/2

Kristeller

32-197-01-01	Fig. 1	115 x 22 mm
32-197-02-01	Fig. 2	115 x 24 mm
32-197-03-01	Fig. 3	115 x 29 mm



1/2

Kristeller

32-199-01-01	Fig. 1	(32-196-01-01 & 32-197-01-01)
32-199-02-01	Fig. 2	(32-196-02-01 & 32-197-02-01)
32-199-03-01	Fig. 3	(32-196-03-01 & 32-197-03-01)

Vaginalspekula, Scheidenhalter

Vaginal Specula, Vaginal Retractors
 Espéculos vaginales, Valvas vaginales
 Spéculums vaginaux, Valves vaginales
 Specoli vaginali, Valve vaginali



tiefes Spekulum
 deep speculum
 espéculo profundo
 spéculum profond
 specolo profondo



1/2

Kristeller

32-202-01-01	Fig. 1	110 x 28 mm
32-202-02-01	Fig. 2	110 x 30 mm
32-202-03-01	Fig. 3	110 x 36 mm



1/2

Kristeller

32-203-01-01	Fig. 1	115 x 23 mm
32-203-02-01	Fig. 2	115 x 26 mm
32-203-03-01	Fig. 3	115 x 32 mm



1/2

Kristeller

32-205-01-01	Fig. 1	(32-202-01-01 & 32-203-01-01)
32-205-02-01	Fig. 2	(32-202-02-01 & 32-203-02-01)
32-205-03-01	Fig. 3	(32-202-03-01 & 32-203-03-01)

Vaginalspekula, Scheidenhalter

Vaginal Specula, Vaginal Retractors
Espéculos vaginales, Valvas vaginales
Spéculums vaginaux, Valves vaginales
Specoli vaginali, Valve vaginali

Gynäkologie

Gynecology
Ginecología
Gynécologie
Ginecologia

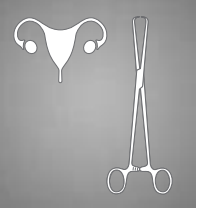

1/2

Kallmorgen

32-232-01-01	Fig. 1	70 x 40 mm
32-232-02-01	Fig. 2	90 x 40 mm



1/2

Kallmorgen

32-233-01-01	Fig. 1	70 x 37 mm
32-233-02-01	Fig. 2	90 x 37 mm



1/2

Kallmorgen

32-235-01-01	Fig. 1	(32-232-01-01 & 32-233-01-01)
32-235-02-01	Fig. 2	(32-232-02-01 & 32-233-02-01)

Vaginalspekula, Scheidenhalter

Vaginal Specula, Vaginal Retractors
Espéculos vaginales, Valvas vaginales
Spéculums vaginaux, Valves vaginales
Specoli vaginali, Valve vaginali



1/2

Doyen

32-249-01-01	58 x 35 mm
32-249-02-01	88 x 35 mm
32-249-03-01	118 x 35 mm

32-250-01-01	60 x 47 mm
32-250-02-01	78 x 47 mm
32-250-03-01	120 x 47 mm
32-250-04-01	165 x 47 mm

32-251-01-01	55 x 60 mm
32-251-02-01	85 x 60 mm
32-251-03-01	115 x 60 mm

Vaginalspekula, Scheidenhalter

Vaginal Specula, Vaginal Retractors
 Espéculos vaginales, Valvas vaginales
 Spéculum vaginaux, Valves vaginales
 Specoli vaginali, Valve vaginali

Gynäkologie

Gynecology
 Ginecología
 Gynécologie
 Ginecologia

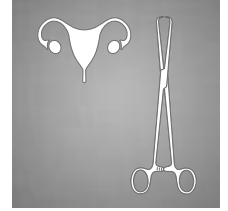

1/2

Scherbak

Blatt, allein
 Specula Blade, only
 Valva vaginal, suelta
 Valve vaginale, seule
 Valve vaginale, sola

1/1

80 x 30 mm
 32-302-01-01

➡ 32-302-14-07

85 x 35 mm
 32-302-02-01

➡ 32-302-14-07

90 x 40 mm
 32-302-03-01

➡ 32-302-14-07

32



1/2

Scherbak

Blatt, allein
 Specula Blade, only
 Valva vaginal, suelta
 Valve vaginale, seule
 Valve vaginale, sola

58 x 40 - 60 mm
 32-302-04-01

➡ 32-302-14-07

70 x 45 - 70 mm
 32-302-05-01

➡ 32-302-14-07

Vaginalspekula

Vaginal Specula

Espéculos vaginales

Spéculums vaginaux

Specoli vaginali

Scherbak

32-302-00-01

Satz komplett mit Griff, Gewicht (400 g) und 5 Blättern
complete set with handle, weight (400 g) and 5 blades
juego completo con mango, peso (400 g) y 5 valvas
jeu complet avec manche, poids (400 g) et 5 valves
Set completo con manico, peso (400 g) e 5 valve



1/2



1/3



1/3

Scherbak

32-302-10-01

10,5 cm / 4" / 400 g

Gewicht zum Vaginalspekulum
Weight for Vaginal Speculum
Peso para espéculo vaginal
Poids pour spéculum vaginal
Peso per specolo vaginale

Scherbak

32-302-12-01

13 cm / 5" / 800 g

Gewicht zum Vaginalspekulum
Weight for Vaginal Speculum
Peso para espéculo vaginal
Poids pour spéculum vaginal
Peso per specolo vaginale

Scherbak

32-302-14-07

20 cm / 7 7/8"

Griff zum Vaginalspekulum
Handle for Vaginal Speculum
Mango para espéculo vaginal
Manche pour spéculum vaginal
Manico per specolo vaginale

Vaginalspekula

Vaginal Specula

Espéculos vaginales

Spéculums vaginaux

Specoli vaginali

Gynäkologie

Gynecology

Ginecología

Gynécologie

Ginecologia

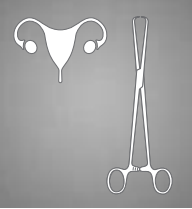

32

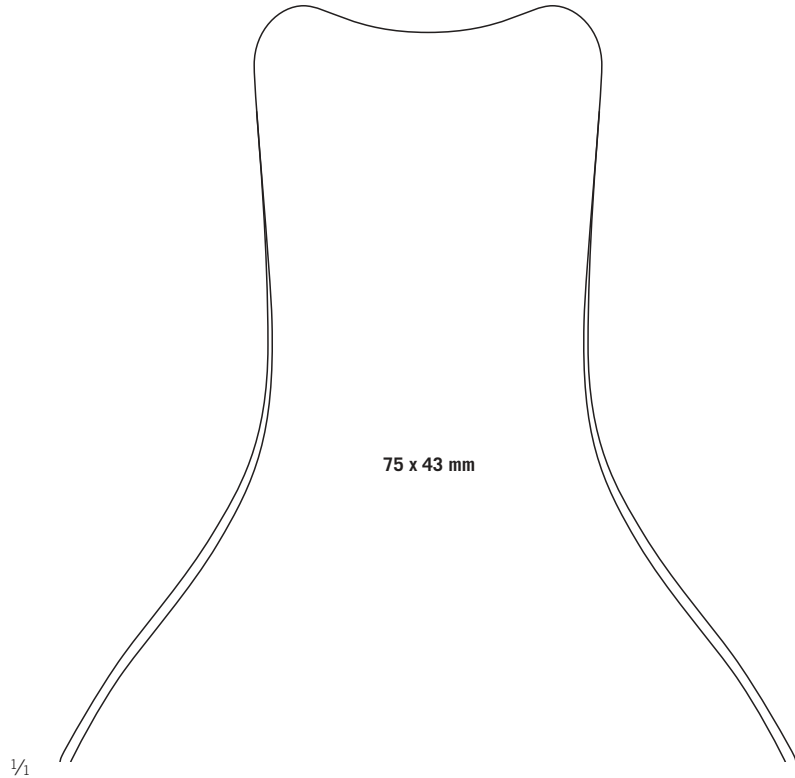

32-310-90-98

Gewicht allein
Weight only
Peso suelta
Poids seul
Peso solo

Auvard

32-310-22-01

23,5 cm / 9 2/8"

komplett, mit abnehmbarem Gewicht
complete, with detachable weight
completo, con peso desmontable
complet, avec poids démontable
completo, con peso smontabile

Vaginalspekula, Scheidenhalter

Vaginal Specula, Vaginal Retractors
 Espécules vaginales, Valvas vaginales
 Spéculums vaginaux, Valves vaginales
 Specoli vaginali, Valve vaginali



80 x 42 mm

1/2

Weissbarth
 32-314-24-02
 21 cm / 8 2/8"

komplett, mit abnehmbarem Auffangsieb
 complete, with detachable strainer
 completo, con tamiz desmontable
 complet, avec tamis démontable
 completo, con crivello smontabile

32-314-99-02

Auffangsieb
 Strainer for Vaginal Speculum
 Tamiz para espéculo vaginal
 Tamis pour spéculum vaginal
 Crivello per specola vaginale



32-314-24-02



1/4

1/2

Breisky
 32-323-20-07 -
 32-323-40-07

32-323-20-07	100 x 20 mm	29,5 cm / 11 5/8"
32-323-25-07	100 x 25 mm	29,5 cm / 11 5/8"
32-323-30-07	100 x 30 mm	29,5 cm / 11 5/8"
32-323-35-07	100 x 35 mm	29,5 cm / 11 5/8"
32-323-40-07	100 x 40 mm	29,5 cm / 11 5/8"

32-324-20-07	130 x 20 mm	32 cm / 12 5/8"
32-324-25-07	130 x 25 mm	32 cm / 12 5/8"
32-324-30-07	130 x 30 mm	32 cm / 12 5/8"
32-324-35-07	130 x 35 mm	32 cm / 12 5/8"
32-324-40-07	130 x 40 mm	32 cm / 12 5/8"

32-325-40-07	160 x 40 mm	35 cm / 13 5/8"
--------------	-------------	-----------------



70 x 30 mm

1/2

Doyen
 32-342-24-01
 25 cm / 9 7/8"

Endospekula, Uterusdilatatoren

Endocervical Specula, Uterine Dilators
Espéculos endocervicales, Dilatadores uterinos
Endospéculums, Dilatateurs du col de l'utérus
Endospecoli, Dilatatori uterini

Gynäkologie

Gynecology
Ginecología
Gynécologie
Ginecologia

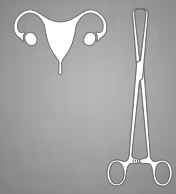

1/2

Kogan
32-381-24-07
24,5 cm / 9 5/8"



1/2

Kogan
32-383-24-07
24,5 cm / 9 5/8"



1/2

Goodell
32-384-34-01
34 cm / 13 3/8"

Uterusdilatoren

Uterine Dilators
Dilatadores uterinos
Dilateurs du col de l'utérus
Dilatatori uterini



mm Ø		
1,0	32-400-01-01	
1,5		32-401-01-01
2,0	32-400-02-01	
2,5		32-401-02-01
3,0	32-400-03-01	
3,5		32-401-03-01
4,0	32-400-04-01	
4,5		32-401-04-01
5,0	32-400-05-01	
5,5		32-401-05-01
6,0	32-400-06-01	
6,5		32-401-06-01
7,0	32-400-07-01	
7,5		32-401-07-01
8,0	32-400-08-01	
8,5		32-401-08-01
9,0	32-400-09-01	
9,5		32-401-09-01
10,0	32-400-10-01	
10,5		32-401-10-01
11,0	32-400-11-01	
11,5		32-401-11-01
12,0	32-400-12-01	
12,5		32-401-12-01
13,0	32-400-13-01	
13,5		32-401-13-01
14,0	32-400-14-01	
14,5		32-401-14-01
15,0	32-400-15-01	
15,5		32-401-15-01
16,0	32-400-16-01	
16,5		32-401-16-01
17,0	32-400-17-01	
17,5		32-401-17-01
18,0	32-400-18-01	
19,0	32-400-19-01	
20,0	32-400-20-01	
21,0	32-400-21-01	
22,0	32-400-22-01	
23,0	32-400-23-01	
24,0	32-400-24-01	
25,0	32-400-25-01	
26,0	32-400-26-01	



1/2

Hegar
32-400-01-01 -
32-401-17-01
18,5 cm / 7 2/8"

32-400-80-01

Satz mit 14 Stück (ganze Größen) von 4,0 bis 17,0 mm **ohne Etui**
set of 14 pieces (full sizes) from 4,0 to 17,0 mm **without case**
juego de 14 piezas (tamaños enteros) de 4,0 a 17,0 mm **sin caja**
jeu de 14 pièces (taille entière) de 4,0 jusqu'à 17,0 mm **sans boîte**
serie di 14 pezzi (grandezza intera) da 4,0 fino a 17,0 mm **senza scatola**

32-400-84-01

Satz mit 14 Stück (ganze Größen) von 4,0 bis 17,0 mm **im Metalletui**
set of 14 pieces (full sizes) from 4,0 to 17,0 mm **in metal case**
juego de 14 piezas (tamaños enteros) de 4,0 a 17,0 mm **en caja metálica**
jeu de 14 pièces (taille entière) de 4,0 jusqu'à 17,0 mm **en boîte métal**
serie di 14 pezzi (grandezza intera) da 4,0 fino a 17,0 mm **in scatola metallica**

32-400-90-01

Satz mit 26 Stück (ganze Größen) von 1,0 bis 26,0 mm **ohne Etui**
set of 26 pieces (full sizes) from 1,0 to 26,0 mm **without case**
juego de 26 piezas (tamaños enteros) de 1,0 a 26,0 mm **sin caja**
jeu de 14 pièces (taille entière) de 1,0 jusqu'à 26,0 mm **sans boîte**
serie di 14 pezzi (grandezza intera) da 1,0 fino a 26,0 mm **senza scatola**

32-400-90-98

Metalletui allein für Ø 4-17 mm
metal case only, for Ø 4-17 mm
caja metálica individual, para Ø 4-17 mm
etui en métal, seul, pour Ø 4-17 mm
scatola metallica singola, per Ø 4-17 mm

Uterusdilatoren

Uterine Dilators
Dilatadores uterinos
Dilateurs du col de l'utérus
Dilatatori uterini

Gynäkologie

Gynecology
Ginecología
Gynécologie
Ginecologia

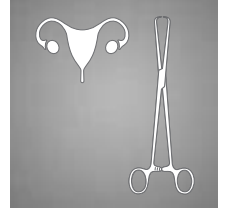

mm Ø	
1,0 / 2,0	32-430-02-01
3,0 / 4,0	32-430-04-01
5,0 / 6,0	32-430-06-01
7,0 / 8,0	32-430-08-01
9,0 / 10,0	32-430-10-01
11,0 / 12,0	32-430-12-01
13,0 / 14,0	32-430-14-01
15,0 / 16,0	32-430-16-01
17,0 / 18,0	32-430-18-01
19,0 / 20,0	32-430-20-01
21,0 / 22,0	32-430-22-01
23,0 / 24,0	32-430-24-01
25,0 / 26,0	32-430-26-01

1/2

Hegar
32-430-02-01 -
32-430-26-01
20 cm / 7 7/8"

32-430-80-01

Satz mit 8 Stück von 3,0 / 4,0 bis 17,0 / 18,0 mm **ohne Etui**
set of 8 pieces from 3,0 / 4,0 to 17,0 / 18,0 mm **without case**
juego de 8 piezas de 3,0 / 4,0 a 17,0 / 18,0 mm **sin caja**
jeu de 8 pièces de 3,0 / 4,0 jusqu'à 17,0 / 18,0 mm **sans boîte**
serie di 8 pezzi da 3,0 / 4,0 fino a 17,0 / 18,0 mm **senza scatola**

Uterusdilatoren

Uterine Dilators

Dilatadores uterinos

Dilateurs du col de l'utérus

Dilatatori uterini



Hegar
32-430-82-01

Satz mit 8 Stück von 3,0 / 4,0 bis 17,0 / 18,0 mm in
auskochbarer Stoffrolltasche

set of 8 pieces from 3,0 / 4,0 to 17,0 / 18,0 mm
in boilable canvas roll

juego de 8 piezas de 3,0 / 4,0 a 17,0 / 18,0 mm en
bolsa de tela esterilizable por ebullición

jeu de 8 pièces de 3,0 / 4,0 jusqu'à 17,0 / 18,0 mm
en pochette en treillis stérilisable par ébullition

serie di 8 pezzi di 3,0 / 4,0 jusqu'à 17,0 / 18,0 mm
in busta di tela sterilizzabile



Hegar
32-430-84-01

Satz mit 8 Stück von 3,0 / 4,0 bis 17,0 / 18,0 mm
im Metalletui

set of 8 pieces from 3,0 / 4,0 to 17,0 / 18,0 mm
in metal case

juego de 8 piezas de 3,0 / 4,0 a 17,0 / 18,0 mm
en caja metálica

jeu de 8 pièces de 3,0 / 4,0 jusqu'à 17,0 / 18,0 mm
en boîte métal

serie di 8 pezzi da 3,0 / 4,0 fino a 17,0 / 18,0 mm
in scatola metallica

Uterusdilatoren

Uterine Dilators
Dilatadores uterinos
Dilatateurs du col de l'utérus
Dilatatori uterini

Gynäkologie

Gynecology
Ginecología
Gynécologie
Ginecologia

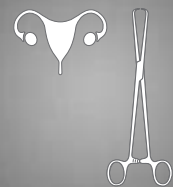

1/2



Hank

32-460-10-01 -
32-460-20-01

26,5 cm / 10 3/8"

amerikanische Skala
American scale
escala americana
échelle américaine
scala americana

	Fig.	mm Ø
32-460-10-01	9 / 10	4,5 / 5,0
32-460-12-01	11 / 12	5,5 / 6,0
32-460-14-01	13 / 14	6,5 / 7,0
32-460-16-01	15 / 16	7,5 / 8,0
32-460-18-01	17 / 18	8,5 / 9,0
32-460-20-01	19 / 20	9,5 / 10,0

Hank

32-460-82-01

Satz mit 6 Stück in auskochbarer
Stoffrolltasche

set of 6 piezas in boilable canvas roll

juego de 6 piezas en bolsa de tela
esterilizable por ebullición

jeu de 6 pièces en pochette en treillis
stérilisable par ébullition

serie di 6 pezzi in busta di tela
sterilizzabile

Uterussonden, Uterusdepressor

Uterine Sounds, Uterine Depressor

Histerómetros, Depresor uterino

Hystéromètres, Dépresseur utérin

Isterometri, Depressore uterino

Cr

∅ 4 mm



1/2

Sims
32-583-32-01

33 cm / 13"

starr
rigid
rigido
rigide
rigido

∅ 4 mm



1/2

Sims
32-584-32-02

33 cm / 13"

biegsam
malleable
maleable
malléable
malleabile

∅ 4 mm



1/2

Valleix
32-593-25-01

27 cm / 10 5/8"



1/2

Braun
32-595-26-07

27 cm / 10 5/8"

Hakenzangen, Amniotom

Uterine Tenaculum Forceps, Amniotome

Pinza para cuello uterino, Amniótomo

Pince pour le col de l'utérus, Amniotome

Pinza per il collo dell'utero, Amniotomo

Gynäkologie

Gynecology

Ginecología

Gynécologie

Ginecologia

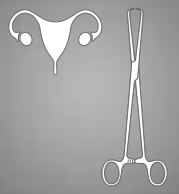

1/2

Schröder
32-622-25-07
25,5 cm / 10 "



1/2

Braun
32-628-25-07
26 cm / 10 2/8 "



1/2

Duplay
32-645-28-07
28 cm / 11 "



1/4

Beacham
32-659-26-07
26 cm / 10 2/8 "

Hakenzangen

Uterine Tenaculum Forceps

Pinza para cuello uterino

Pince pour le col de l'utérus

Pinza per il collo dell'utero



1/2

Skene
32-663-24-07
24 cm / 9 4/8"



1:1



1/1

32-682-24-07

1/2

Schröder
32-682-24-07 -
32-683-24-07
25 cm / 9 7/8"



2:2



1/1

32-683-24-07

1/2

Teale
32-697-23-07
23 cm / 9"



4:5

Hakenzangen

Uterine Tenaculum Forceps

Pinza para cuello uterino

Pince pour le col de l'utérus

Pinza per il collo dell'utero

Gynäkologie

Gynecology

Ginecología

Gynécologie

Ginecologia

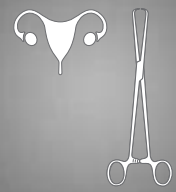

Iowa
32-699-26-07
26 cm / 10 2/8"

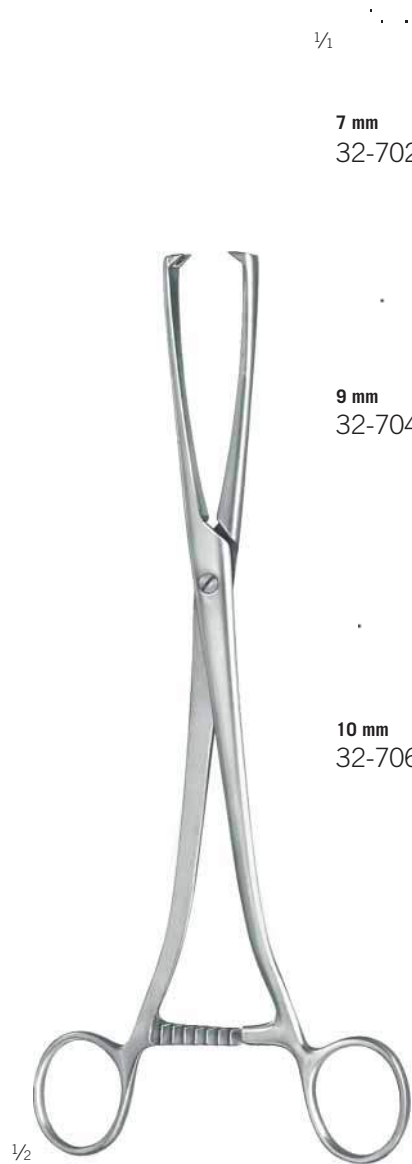

Museux
32-702-24-07 -
32-706-24-07
24 cm / 9 4/8"



Jacobs
32-728-21-07
21 cm / 8 2/8"



Hakenzangen

Uterine Tenaculum Forceps

Pinza para cuello uterino

Pince pour le col de l'utérus

Pinza per il collo dell'utero

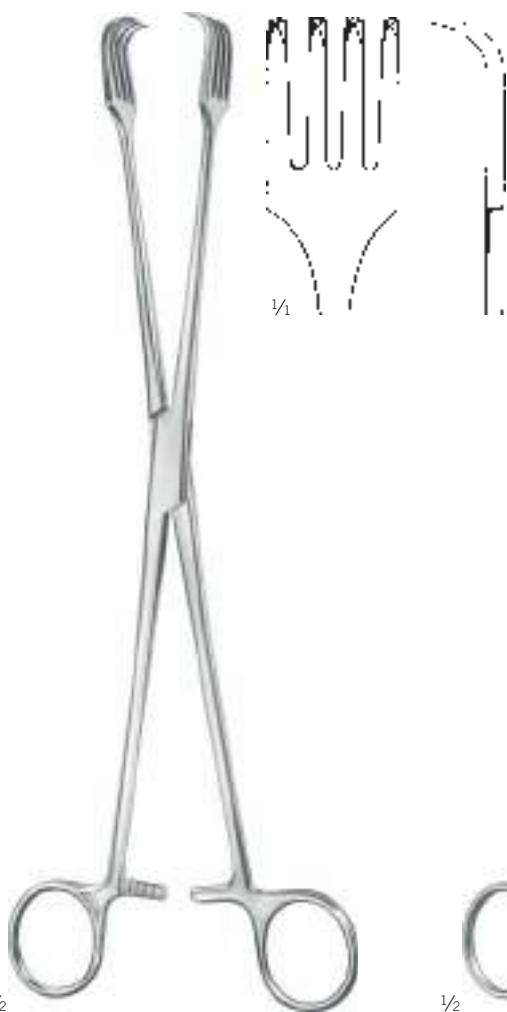

32-734-26-07
26,5 cm / 10 3/8"



Braun
32-738-16-07
16 cm / 6 2/8"



Czerny
32-740-21-07
21 cm / 8 3/8"



Uterus-Polypenzangen

Uterine Polypus Forceps
Pinzas para pólipos uterinos
Pincers à polypes utérins
Pinze per polipi uterini

Gynäkologie

Gynecology
Ginecología
Gynécologie
Ginecologia

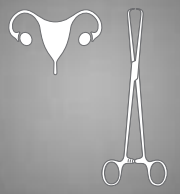

$\frac{1}{2}$

Kelly
32-741-32-07
31,5 cm / 12 $\frac{3}{8}$ "



$\frac{1}{2}$

Noto
32-744-27-07
27 cm / 10 $\frac{5}{8}$ "



$\frac{1}{2}$

Heywood-Smith
32-745-25-07
26 cm / 10 $\frac{2}{8}$ "

Myomheber, Myommesser
Myoma Screws, Myoma Knife
Tirabuzones para fibroma, Cuchillo para fibroma
Tracteurs pour fibromes, Evideur de fibromes
Tiramiomi, Bisturi per fibromi



Doyen
32-758-17-07
17 cm / 6 5/8"



Doyen
32-760-17-07
15 cm / 5 7/8"



Segond
32-762-27-07
28 cm / 11"

Uterusfasszange

Uterine Seizing Forceps

Histerólabos

Pinces hystérolabes

Pinze isterolabi

Gynäkologie

Gynecology

Ginecología

Gynécologie

Ginecologia

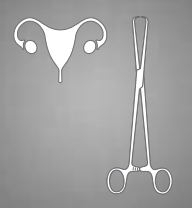

1/1

1/2

Dartigues
32-773-27-07
27 cm / 10 5/8"



1/1

1/2

Somer
32-779-23-07
22,5 cm / 8 7/8"



1/1

1/2

Collin
32-793-25-07
26 cm / 10 2/8"

Fistelhaken

Fistula Hooks

Ganchos para fístulas

Crochets pour fistules

Uncini per fistole



Ayre

32-801-23-07

23,5 cm / 9 2/8"

Konisationsmesser

Conization Knife

Bisturí para cono

Bistouri pour le cône d'attraction

Bisturi per il cono d'attrazione



Emmett

32-804-03-07

23 cm / 9"



Simon

32-806-22-07

21,5 cm / 8 4/8"



Simon

32-808-22-07

21,5 cm / 8 4/8"

Saugküretten, Biopsieküretten

Suction Curettes
Curetas aspiradoras
Curettes à aspiration
Curette d'aspirazione

Gynäkologie

Gynecology
Ginecología
Gynécologie
Ginecologia

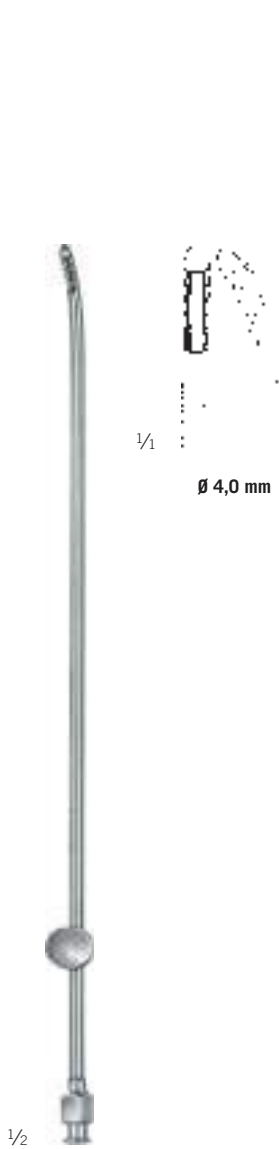
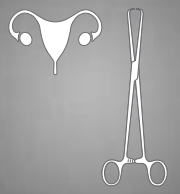

Novak
32-825-23-01

24,5 cm / 9 5/8"

mit Luer-Lock Ansatz
with Luer-Lock connection
con conexión Luer-Lock
avec connection Luer-Lock
con raccordo Luer-Lock



Kevorkian
32-827-30-07

30 cm / 11 5/8"



Mod. München
32-829-27-07

27 cm / 10 5/8"

Probeexzisionszangen

Uterine Biopsy Forceps

Pinzas para biopsia

Pinces pour biopsie

Pinze per biopsia



Gellhorn
32-841-23-07
24 cm / 9 4/8"



Faure
32-843-21-07
21 cm / 8 2/8"



Schubert
32-846-21-07 -
32-846-28-07

Probeexzisionszangen

Uterine Biopsy Forceps

Pinzas para biopsia

Pinces pour biopsie

Pinze per biopsia

Gynäkologie

Gynecology

Ginecología

Gynécologie

Ginecologia

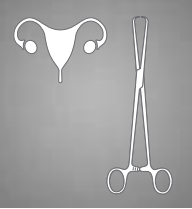

1/2



1/1



∅ 5,6 mm
32-851-22-07
21 cm / 8 2/8"



∅ 5,6 mm
32-851-24-07
24 cm / 9 4/8"

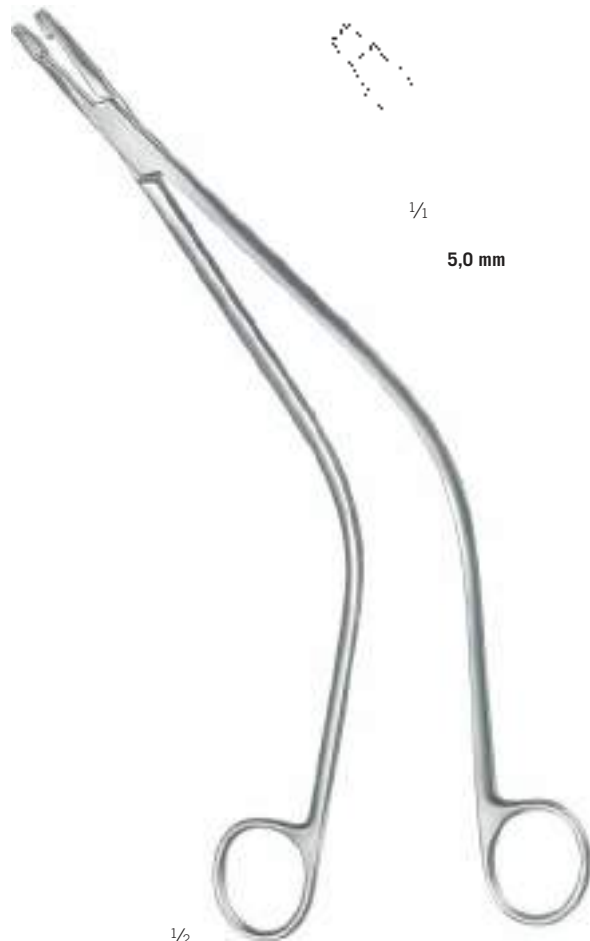

1/2



1/1

5,0 mm

Thoms-Gaylor
32-851-22-07 -
32-851-24-07

Schubert
32-853-26-07
24 cm / 9 4/8"

Probeexzisionszangen

Uterine Biopsy Forceps

Pinzas para biopsia

Pinces pour biopsie

Pinze per biopsia



Van Doren
32-855-24-07
27 cm / 10 $\frac{5}{8}$ "



Van Doren
32-855-25-07
25,5 cm / 10 "

Probeexzisionszangen

Uterine Biopsy Forceps

Pinzas para biopsia

Pinces pour biopsie

Pinze per biopsia

Gynäkologie

Gynecology

Ginecología

Gynécologie

Ginecologia

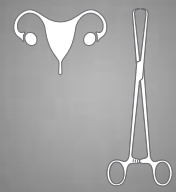

Alexander
32-857-28-07

retrograder Schnitt, Maul nach links gebogen, geeignet für Kolposkopie
retrograde cutting, jaws curved to left, suitable als in colposcopy
corte retrograde, boca curva hacia izquierda, utilizable en colposcopia
coupe retrograde, mors courbé vers gauche, approprié pour colposcopie
filo retrogrado, morso curvato verso, adatto per colposcopia

Schaftlänge
shaft length
longitud del vástago
longueur de la tige
lunghezza dell'asta
195 mm

Maul 5,1 mm breit
jaw 5,1 mm wide
boca 5,1 mm de ancho
mors largeur 5,1 mm
morso larghezza 5,1 mm



Kevorkian
32-859-32-07

Schaftlänge
shaft length
longitud del vástago
longueur de la tige
lunghezza dell'asta
230 mm

Maul 3 mm breit
jaw 3 mm wide
boca 3 mm de ancho
mors largeur 3 mm
morso larghezza 3 mm

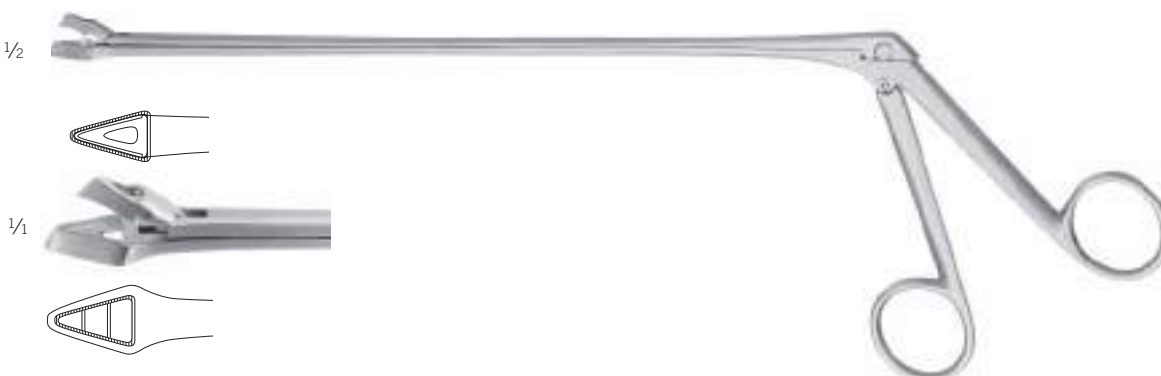

Schumacher
32-861-02-07

Schaftlänge
shaft length
longitud del vástago
longueur de la tige
lunghezza dell'asta
225 mm

Maul 5,4 mm breit
jaw 5,4 mm wide
boca 5,4 mm de ancho
mors largeur 5,4 mm
morso larghezza 5,4 mm

Probeexzisionszangen, IUP-Fasszangen

Uterine Biopsy Forceps, IUP Grasping Forceps

Pinzas para biopsia, Pinzas para coger DIU

Pinces pour biopsie, Pinces pour DIU

Pinze per biopsia, Pinze per DIU



Schumacher
32-865-00-07 -
32-865-01-07
25 cm / 9 5/8"

32-865-00-07
Set, komplett, bestehend aus: Set, complete, consisting of: Juego, completo, formado por: Jeu, complet, composé de: Serie completa, consistente in:
39-581-01-07
39-584-20-07
32-865-01-07

Verlängerungsrohr Interchangeable tube Tubo de extension Tube rallonge Tubo allunghi
39-584-20-07 22 cm
39-584-30-07 32 cm
39-584-40-07 41 cm

Handgriff Handle Mango Manche Manico
39-581-01-07

Aufsatz Tip Punta Embout Punta
32-865-01-07



32-866-22-07		1:2
27 cm / 10 5/8"		
Ø 3,0 mm		
Schaftlänge shaft length longitud del vástago longueur de la tige lunghezza dell'asta		
225 mm		

flexibler Schaft
flexible shaft
vástago flexible
tige flexible
asta flessibile

32-866-28-07		1:2
32 cm / 12 5/8"		
Ø 3,0 mm		
Schaftlänge shaft length longitud del vástago longueur de la tige lunghezza dell'asta		
270 mm		

flexibler Schaft
flexible shaft
vástago flexible
tige flexible
asta flessibile

Uteruslöffel, Uterusküretten

Uterine Scoops, Uterine Curettes
 Cucharillas uterinas, Curetas uterinas
 Curettes utérines, Curettes utérines
 Curette uterine, Curette uterine

Gynäkologie

Gynecology
 Ginecología
 Gynécologie
 Ginecologia

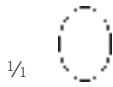
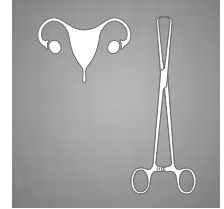

Fig. 1
 32-900-01-07
 23 cm / 9"
 10 x 7 mm



Fig. 2
 32-900-02-07
 23,5 cm / 9 2/8"
 12 x 8 mm



Fig. 3
 32-900-03-07
 24 cm / 9 4/8"
 13 x 10 mm



Fig. 4
 32-900-04-07
 24 cm / 9 4/8"
 16 x 12 mm



Fig. 5
 32-900-05-07
 24 cm / 9 4/8"
 18 x 13 mm



Fig. 6
 32-900-06-07
 24 cm / 9 4/8"
 20 x 15 mm

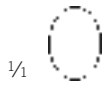

Fig. 1
 32-906-01-07
 10 x 7 mm



Fig. 2
 32-906-02-07
 12 x 8 mm



Fig. 3
 32-906-03-07
 13 x 10 mm



Fig. 4
 32-906-04-07
 16 x 12 mm



Fig. 5
 32-906-05-07
 18 x 13 mm



Fig. 6
 32-906-06-07
 20 x 15 mm



13 mm
 stumpf
 blunt
 romo
 mousse
 musso

8 mm
 scharf
 sharp
 cortante
 tranchante
 tagliente



1/2

Simon
 32-900-01-07 -
 32-900-06-07
 scharf, fest
 sharp, rigid
 cortante, rigido
 tranchante, rigide
 tagliente, rigido



1/2

Simon
 32-906-01-07 -
 32-906-06-07
 30 cm / 11 5/8"
 scharf, fest
 sharp, rigid
 cortante, rigido
 tranchante, rigide
 tagliente, rigido



1/2

Blake
 32-919-00-07
 27,5 cm / 10 7/8"

Uterusküretten

Uterine Curettes
Curetas uterinas
Curettes utérines
Curette uterine



Recamier Recamier Sims Sims
32-920-05-07 - 32-920-40-07 32-921-05-07 - 32-921-40-07 32-926-05-07 - 32-926-40-07 32-927-05-07 - 32-927-40-07

Fig	Breite width anchura largeur larghezza	scharf, fest sharp, rigid cortante, rígido tranchante, rigide tagliente, rigido	scharf, biegsam sharp, malleable cortante, maleable tranchante, malléable tagliente, malleabile
00	5 mm	32-920-05-07	32-921-05-07
0	6 mm	32-920-06-07	32-921-06-07
1	7 mm	32-920-07-07	32-921-07-07
2	8 mm	32-920-08-07	32-921-08-07
3	9 mm	32-920-09-07	32-921-09-07
4	11 mm	32-920-11-07	32-921-11-07
5	12 mm	32-920-12-07	32-921-12-07
6	14 mm	32-920-14-07	32-921-14-07
7	15 mm	32-920-15-07	32-921-15-07
8	16 mm	32-920-16-07	32-921-16-07
9	19 mm	32-920-19-07	32-921-19-07
10	20 mm	32-920-20-07	32-921-20-07
11	21 mm	32-920-21-07	32-921-21-07
12	23 mm	32-920-23-07	32-921-23-07
13	25 mm	32-920-25-07	32-921-25-07
14	30 mm	32-920-30-07	32-921-30-07
15	35 mm	32-920-35-07	32-921-35-07
16	40 mm	32-920-40-07	32-921-40-07

Fig	Breite width anchura largeur larghezza	stumpf, fest blunt, rigid romo, rígido mousse, rigide smusso, rigido	stumpf, biegsam blunt, malleable romo, maleable mousse, malléable smusso, malleabile
00	5 mm	32-926-05-07	32-927-05-07
0	6 mm	32-926-06-07	32-927-06-07
1	7 mm	32-926-07-07	32-927-07-07
2	8 mm	32-926-08-07	32-927-08-07
3	9 mm	32-926-09-07	32-927-09-07
4	11 mm	32-926-11-07	32-927-11-07
5	12 mm	32-926-12-07	32-927-12-07
6	14 mm	32-926-14-07	32-927-14-07
7	15 mm	32-926-15-07	32-927-15-07
8	16 mm	32-926-16-07	32-927-16-07
9	19 mm	32-926-19-07	32-927-19-07
10	20 mm	32-926-20-07	32-927-20-07
11	21 mm	32-926-21-07	32-927-21-07
12	23 mm	32-926-23-07	32-927-23-07
13	25 mm	32-926-25-07	32-927-25-07
14	30 mm	32-926-30-07	32-927-30-07
15	35 mm	32-926-35-07	32-927-35-07
16	40 mm	32-926-40-07	32-927-40-07

Uterusküretten

Uterine Curettes
Curetas uterinas
Curettes utérines
Curette uterine

Gynäkologie

Gynecology
Ginecología
Gynécologie
Ginecologia

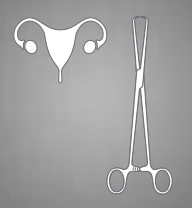

Uterusküretten, Absaugküretten

Uterine Curettes, Suction Curettes

Curetas uterinas, Curetas aspiradoras

Curettes utérines, Curettes d'aspiration

Curette uterine, Curette per aspirazione

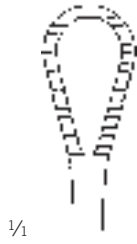

1/1

10 mm
32-924-10-07



1/1

Ø 3,0 mm
32-989-03-01



Ø 4,5 mm
32-989-04-01



Ø 6,0 mm
32-989-06-01

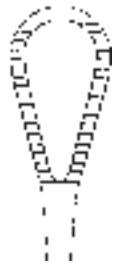

12 mm
32-924-12-07



Ø 8,0 mm
32-989-08-01



Ø 10 mm
32-989-10-01



Ø 12 mm
32-989-12-01



1/2

Greene
32-924-10-07 -
32-924-14-07
28 cm / 11 "



1/2

32-989-03-01 -
32-989-14-01
29 cm / 11 3/8"



Ø 14 mm
32-989-14-01



1/2

32-989-50-01
11 cm / 4 3/8"
Kupplungsstück
Coupling Piece
Pieza de acoplamiento
Pièce de raccordement
Pezzo di collegamento

Salpingograph

Salpingograph
Salpingógrafo
Salpingographe
Salpingografo

Gynäkologie

Gynecology
Ginecología
Gynécologie
Ginecologia

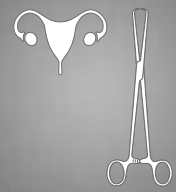

32



➔ 32-995-00-02,
32-995-01-02



Schultze

32-995-00-02

29,5 cm / 11 5/8"

Set komplett, im Holzetui
Set complete, in wooden case
Juego completo, en estuche de madera
Jeu complet, en boîte de bois
Set completo, in scatola di legno

1/2

32-995-01-02

29,5 cm / 11 5/8"

Set komplett (ohne Manometer)
Set complete (without manometer)
Juego completo (sin manómetro)
Jeu complet (sans manomètre)
Set completo (senza manometro)

1/2

32-995-02-02

Manometer zum Salpingograph
Manometer for Salpingograph
Manómetro para salpingógrafo
Manomètre pour salpingographe
Manometro per salpingografo

Geburtshilfe
Obstetrics
Obstetricia
Obstétrique
Ostetricia

33

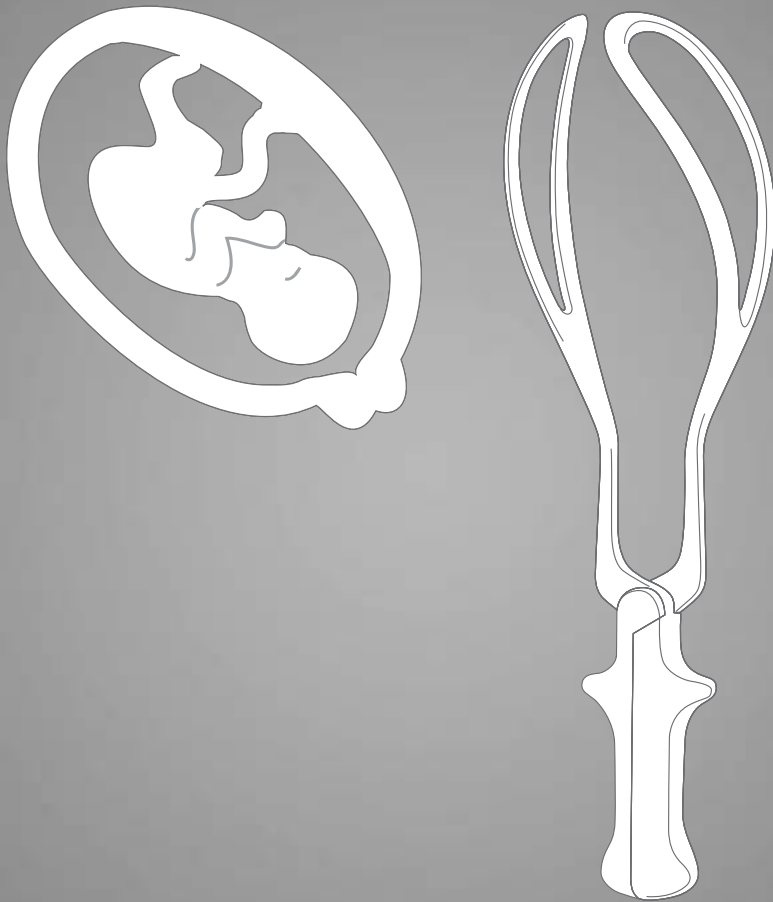

Beckenzirkel, Geburtszangen

Pelvimeter

Pelvímetro

Pelvimètre

Pelvimetri



Skala in cm und Inch
cm / inch scale
escala en cm / pulgadas
échelle en cm / pouces
scal in cm / pollici

¼

Martin
33-103-34-07
35 cm / 13 ⅝"



¼

Nägele
33-141-36-07 = 36,5 cm / 14 ⅜"
33-141-40-07 = 40,5 cm / 16 "



¼

Simpson
33-145-30-07
30,5 cm / 12"



¼

Wrigley
33-146-28-07
28 cm / 11"



¼

Simpson
33-149-36-07
36,5 cm / 14 ⅜"

Geburtszangen

Obstetrical Forceps
Forceps obstétricos
Forceps obstétriques
Forcipi obstetrici

Geburtshilfe

Obstetrics
Obstetricia
Obstétrique
Ostetricia



¼

Kielland
33-195-41-07
41 cm / 16 ½"



¼

Kielland-Luikart
33-197-40-07
40 cm / 15 ⅝"



¼

Piper
33-198-44-07
44,5 cm / 17 ¼"

Abortuszangen

Placenta and Ovum Forceps

Pinzas para aborto

Pinces placentaires et pour poste-abortum

Pinze per placenta e per ovaie



Green-Armytage
33-300-21-07

21 cm / 8 ²/₈"

Klemmzange
Uterine Clamp
Pinza uterina para hemostasis
Pince utérine pour hémostase
Pinza emostatiche per tagli cesarei



Sänger
33-328-27-07 -
33-329-27-07



33-328-27-07
27,5 cm / 10 ⁷/₈"



33-329-27-07
27 cm / 10 ⁵/₈"



Winter
33-344-01-07 -
33-345-02-07
28 cm / 11"



Fig. 1
33-344-01-07

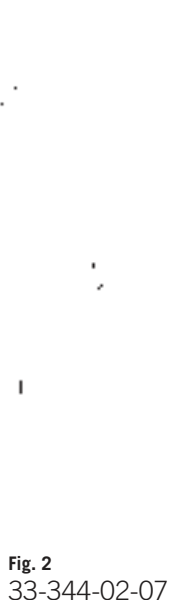

Fig. 2
33-344-02-07



Fig. 1
33-345-01-07



Fig. 2
33-345-02-07



Sellheim
33-309-28-07
32 cm / 12 ⁵/₈"
Geburtslöffel
Obstetrical Lever
Elevador obstétrico
Levier obstétrique
Leva ostetrica

Abortuslöffel

Placenta Scoops

Cucharillas para aborto

Curettes a avortement et placenta

Cucchiai per placenta e ovaie

Geburtshilfe

Obstetrics

Obstetricia

Obstétrique

Ostetricia



33



1/1

17 mm
33-382-01-07

20 mm
33-382-02-07

23 mm
33-382-03-07

1/2

Cuzzi

33-382-01-07 -
33-382-03-07

30 cm / 11 5/8"

stumpf, Rückseite gerieft
blunt, backside serrated
romo, dorso estriado
mousse, verso estrie
smusso, dorso scanallato

Abortuslöffel, Nabelschnurklemme

Placenta Scoops, Umbilical Cord Clamp

Cucharillas para aborto, Clamp umbilical

Curettes a avortement et placenta, Clamp pour le cordon ombilical

Cucchiai per placenta e ovaie, Clamp ombelicale



1/1

1/1

Pestalozza
33-386-30-07
30,5 cm / 12 "



1/2

Collin
33-465-09-07
8,5 cm / 3 3/8"

Messzirkel
Calipers
Compasses
Compas
Compassi

35

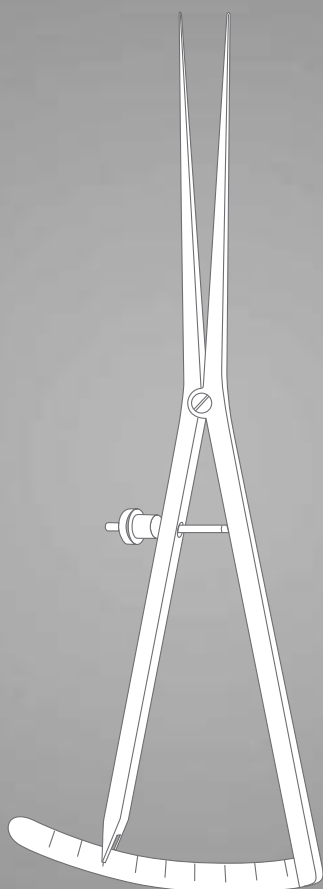

Messzirkel, Kellenmesser

Calipers, Trowel Knives
Compases, Cuchillos de paleta
Compas, Couteaux de truelle
Compassi, Coltelli di cazzuola

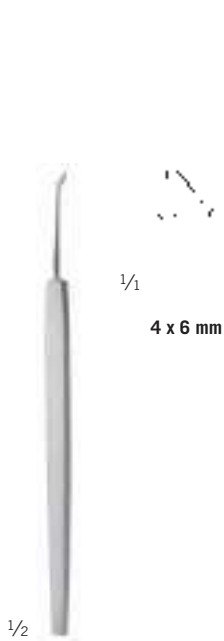

34-370-01-07
12 cm / 6 ⁵/₈"



34-370-02-07
16 cm / 6 ²/₈"



Castroviejo
35-133-06-07
8 cm / 3 ¹/₈"
Messbereich
effective range
alcance eficaz
série effectif
rango effective
0-15 mm



Castroviejo
35-133-07-07
8 cm / 3 ¹/₈"
Messbereich
effective range
alcance eficaz
série effectif
rango effective
0-20 mm



Castroviejo
35-133-09-07
8 cm / 3 ¹/₈"
Messbereich
effective range
alcance eficaz
série effectif
rango effective
0-20 mm



Castroviejo-Epker
35-134-09-07
9 cm / 3 ⁴/₈"
Messbereich
effective range
alcance eficaz
série effectif
rango effective
0-40 mm



Castroviejo-Epker
35-134-18-07
18 cm / 7 ¹/₈"
Messbereich
effective range
alcance eficaz
série effectif
rango effective
0-40 mm

Sonden

Probes
Sondas
Sondes
Sonde

Messzirkel

Calipers
Compasses
Compas
Compassi

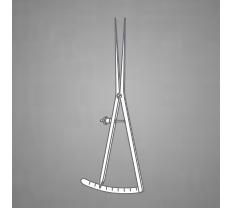

Ag



1/1

Bowman
35-220-00-18 -
35-220-88-18
13 cm / 5 1/8"

	Fig.
35-220-00-18	0 / 0
35-220-11-18	1 / 1
35-220-22-18	2 / 2
35-220-33-18	3 / 3
35-220-44-18	4 / 4
35-220-55-18	5 / 5
35-220-66-18	6 / 6
35-220-77-18	7 / 7
35-220-88-18	8 / 8



1/1

Bowman
35-224-00-18 -
35-224-78-18
13 cm / 5 1/8"

	Fig.
35-224-99-18	0000 / 000
35-224-00-18	00 / 0
35-224-01-18	0 / 1
35-224-12-18	1 / 2
35-224-23-18	2 / 3
35-224-34-18	3 / 4
35-224-45-18	4 / 5
35-224-56-18	5 / 6
35-224-67-18	6 / 7
35-224-78-18	7 / 8



1/1

Bowman
35-226-00-18 -
35-226-78-18
13 cm / 5 1/8"

	Fig.
35-226-00-18	00 / 0
35-226-01-18	0 / 1
35-226-12-18	1 / 2
35-226-23-18	2 / 3
35-226-34-18	3 / 4
35-226-45-18	4 / 5
35-226-56-18	5 / 6
35-226-67-18	6 / 7
35-226-78-18	7 / 8

Otologie
Otology
Otología
Otologie
Otologia

36



Mikro-Ohrzängchen

Micro Ear Forceps
 Micro pinzas auriculares
 Micro Pince auriculaires
 Micro Pinze auricolari

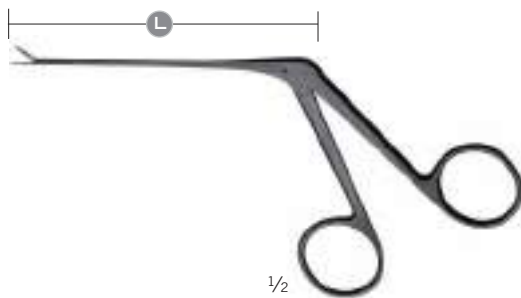
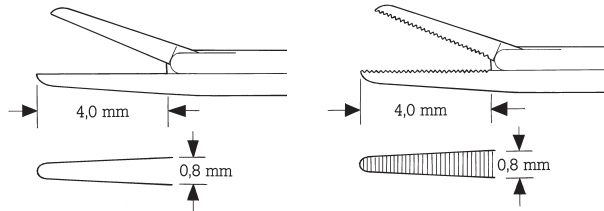

36-001-01-02 -
 36-001-09-02

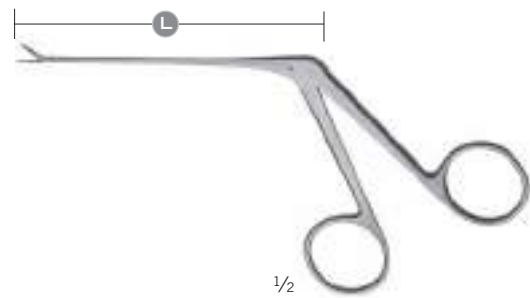

36-001-01-07 -
 36-001-09-07

	gerade, glatt straight, smooth recta, lisa droite, lisse retta, liscia	gerade, gerieft straight, serrated recta, estriada droite, striée retta, con scanalatura	aufgebogen, gerieft bent upwards, serrated curva por arriba, estriada courbée v. le haut, striée curva in alto, con scanalatura	rechts, gerieft right, serrated derecha, estriada droite, striée destra, con scanalatura	links, gerieft left, serrated izquierda, estriada gauche, striée sinistra, con scanalatura
1/1					
L	8 cm	8 cm	8 cm	8 cm	8 cm
SB	36-001-01-02	36-001-06-02	36-001-07-02	36-001-08-02	36-001-09-02
St	36-001-01-07	36-001-06-07	36-001-07-07	36-001-08-07	36-001-09-07

Mikro-Ohrzängchen

Micro Ear Forceps
 Micro pinzas auriculares
 Micro Pince auriculaires
 Micro Pinze auricolari

Otologie
 Otology
 Otología
 Otologie
 Otologia

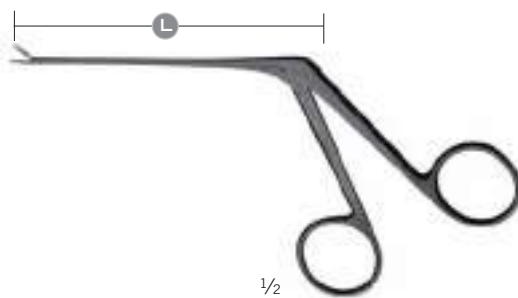
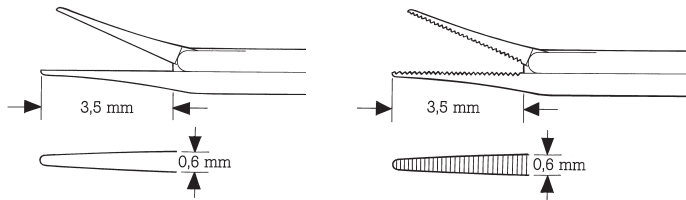
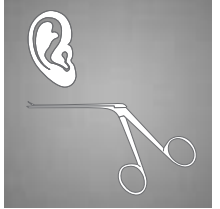

Mini-McGee
 36-001-11-02 -
 36-001-16-02

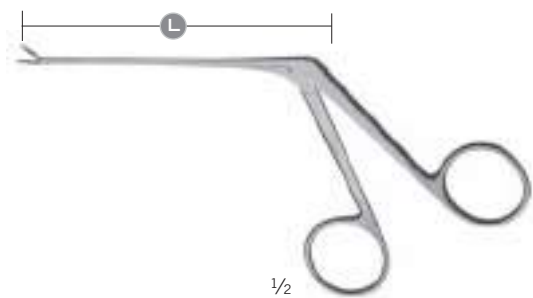

Mini-McGee
 36-001-11-07 -
 36-001-16-07

36

	gerade, glatt straight, smooth recta, lisa droite, lisse retta, liscia	gerade, gerieft straight, serrated recta, estriada droite, striée retta, con scanalatura
1/1	—	—
L	8 cm	8 cm
SB	36-001-11-02	36-001-16-02
St	36-001-11-07	36-001-16-07

Mikro-Ohrzängchen

Micro Ear Forceps

Micro pinzas auriculares

Micro Pince auriculaires

Micro Pinze auricolari

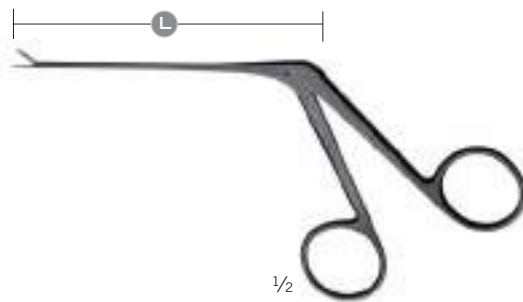
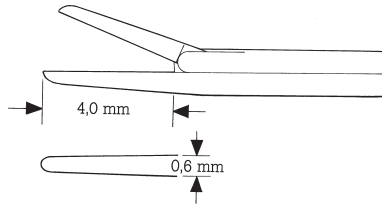

36-001-21-02

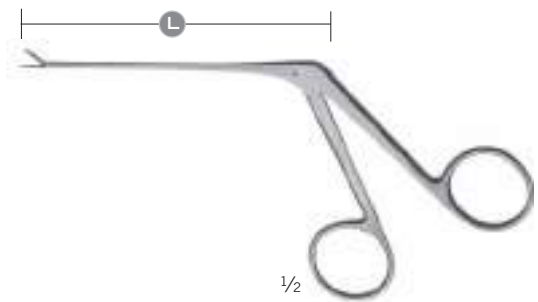

36-001-21-07

	<p>gerade, glatt straight, smooth recta, lisa droite, lisse retta, liscia</p>
1/1	.
L	8 cm
SB	36-001-21-02
St	36-001-21-07

Mikro-Ohrzängchen

Micro Ear Forceps
 Micro pinzas auriculares
 Micro Pince auriculaires
 Micro Pinze auricolari

Otologie
 Otology
 Otología
 Otologie
 Otologia

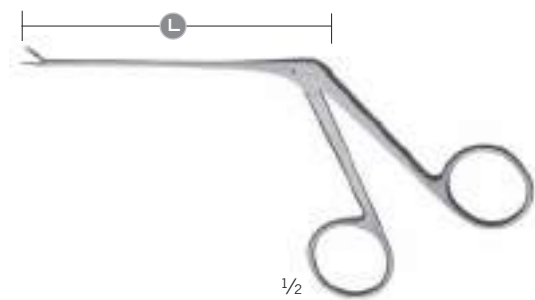
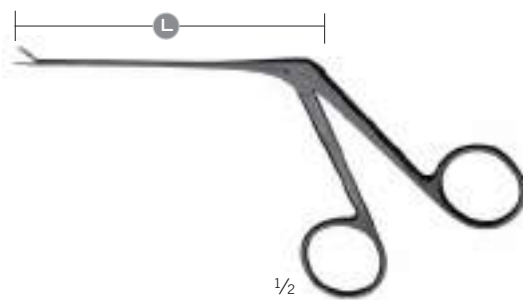
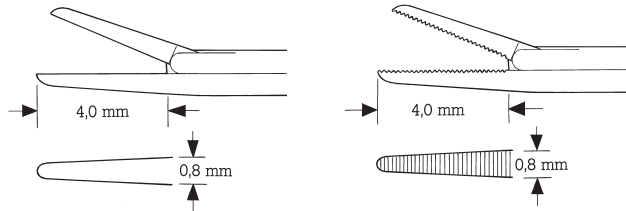
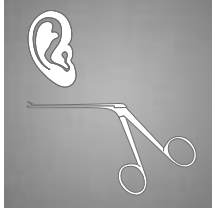

36-001-26-02 -
 36-001-29-02

36-001-26-07 -
 36-001-29-07

36

	gerade, gerieft straight, serrated recta, estriada droite, striée retta, con scanalatura	aufgebogen, gerieft bent upwards, serrated curva por arriba, estriada courbée v. le haut, striée curva in alto, con scanalatura	rechts, gerieft right, serrated derecha, estriada droite, striée destra, con scanalatura	links, gerieft left, serrated izquierda, estriada gauche, striée sinistra, con scanalatura
1/1				
L	8 cm	8 cm	8 cm	8 cm
SB	36-001-26-02	36-001-27-02	36-001-28-02	36-001-29-02
St	36-001-26-07	36-001-27-07	36-001-28-07	36-001-29-07

Mikro-Ohrzängchen

Micro Ear Forceps

Micro pinzas auriculares

Micro Pince auriculaires

Micro Pinze auricolari

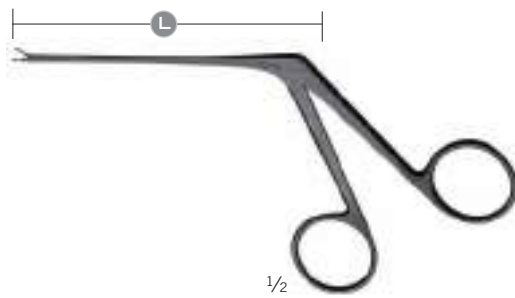
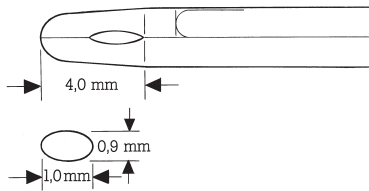

36-003-01-02 -
36-003-04-02

Löffel
cup
cucharilla
curette
cucchiaio

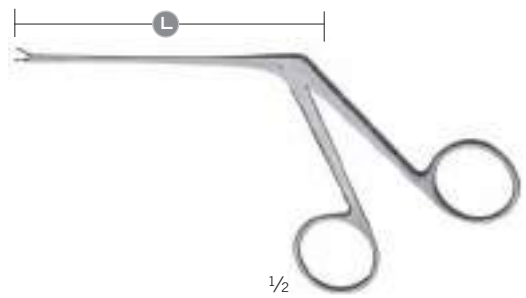

36-003-01-07 -
36-003-04-07

Löffel
cup
cucharilla
curette
cucchiaio

	gerade straight recta droite retta	aufgebogen bent upwards curva por arriba courbée en haut curva in alto	rechts right derecha droite destra	links left izquierda gauche sinistra
1/1	• •	• •	•	• •
L	8 cm	8 cm	8 cm	8 cm
SB	36-003-01-02	36-003-02-02	36-003-03-02	36-003-04-02
St	36-003-01-07	36-003-02-07	36-003-03-07	36-003-04-07

Mikro-Ohrzängchen

Micro Ear Forceps
 Micro pinzas auriculares
 Micro Pince auriculaires
 Micro Pinze auricolari

Otologie
 Otology
 Otología
 Otologie
 Otologia

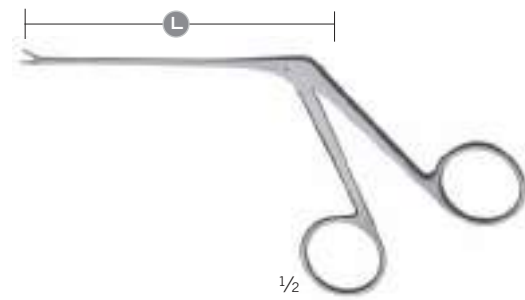
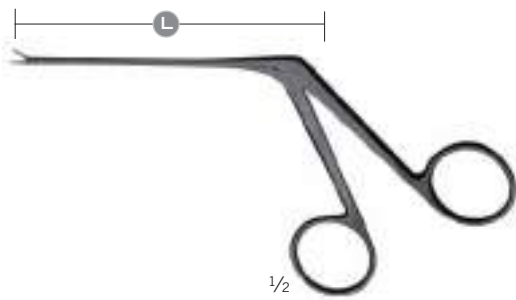
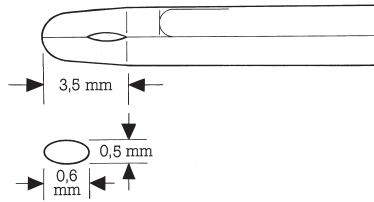
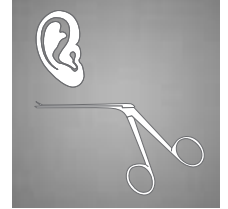

Mini-McGee
 36-003-11-02 -
 36-003-14-02

Löffel
 cup
 cucharilla
 curette
 cucchiaio

Mini-McGee
 36-003-11-07 -
 36-003-14-07

Löffel
 cup
 cucharilla
 curette
 cucchiaio

	gerade straight recta droite retta	aufgebogen bent upwards curva por arriba courbée en haut curva in alto	rechts right derecha droite destra	links left izquierda gauche sinistra
1/1
L	8 cm	8 cm	8 cm	8 cm
SB	36-003-11-02	36-003-12-02	36-003-13-02	36-003-14-02
St	36-003-11-07	36-003-12-07	36-003-13-07	36-003-14-07

Mikro-Ohrscherchen

Micro Ear Scissors

Micro tijeras auriculares

Micro Ciseaux auriculaires

Micro Forbici auricolari

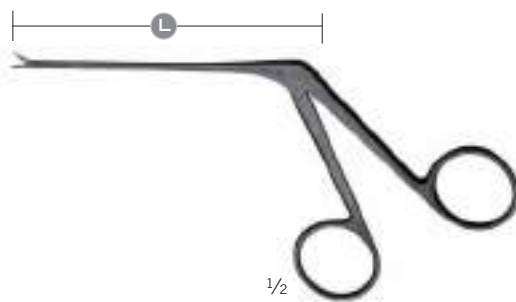
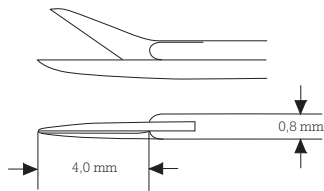

Bellucci
36-005-01-02 -
36-005-04-02

sehr fein
very delicate
muy fino
très fin
strafino

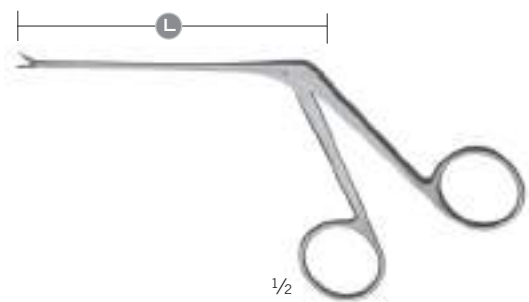

Bellucci
36-005-01-07 -
36-005-04-07

sehr fein
very delicate
muy fino
très fin
strafino

	gerade straight recta droite retta	aufgebogen bent upwards curva por arriba courbée en haut curva in alto	rechts right derecha droite destra	links left izquierda gauche sinistra
1/1				
L	8 cm	8 cm	8 cm	8 cm
SB	36-005-01-02	36-005-02-02	36-005-03-02	36-005-04-02
St	36-005-01-07	36-005-02-07	36-005-03-07	36-005-04-07

Mikro-Ohrscherchen

Micro Ear Scissors
 Micro tijeras auriculares
 Micro Ciseaux auriculaires
 Micro Forbici auricolari

Otologie

Otology
 Otología
 Otologie
 Otologia

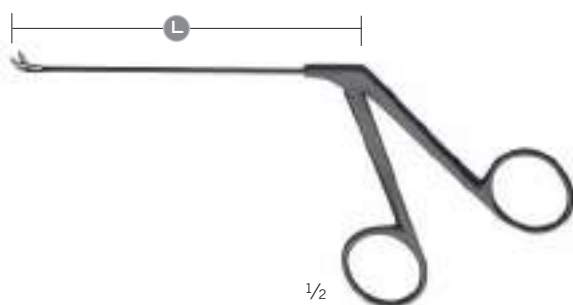
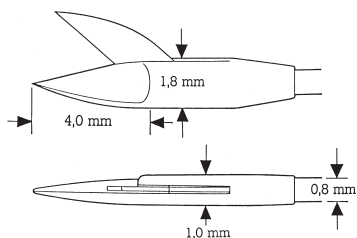
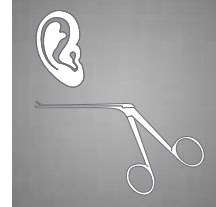

Wullstein
 36-005-51-02 -
 36-005-54-02

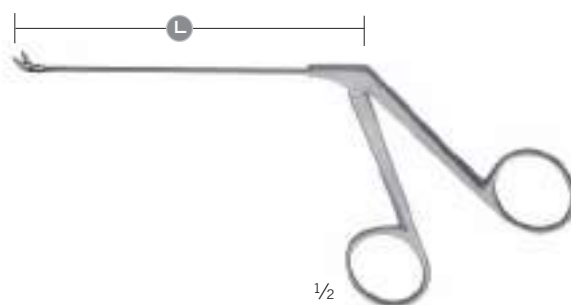

Wullstein
 36-005-51-07 -
 36-005-54-07

36

	gerade straight recta droite retta	aufgebogen bent upwards curva por arriba courbée en haut curva in alto	rechts right derecha droite destra	links left izquierda gauche sinistra
1/1				
L	9 cm	9 cm	9 cm	9 cm
SB	36-005-51-02	36-005-52-02	36-005-53-02	36-005-54-02
St	36-005-51-07	36-005-52-07	36-005-53-07	36-005-54-07

Mikro-Ohrzängchen

Micro Ear Forceps
 Micro pinzas auriculares
 Micro Pince auriculaires
 Micro Pinze auricolari

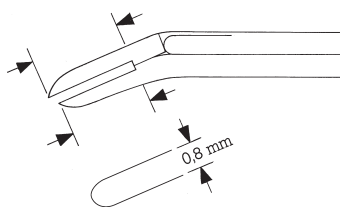

1/2

McGee
 36-010-11-02 -
 36-010-12-02

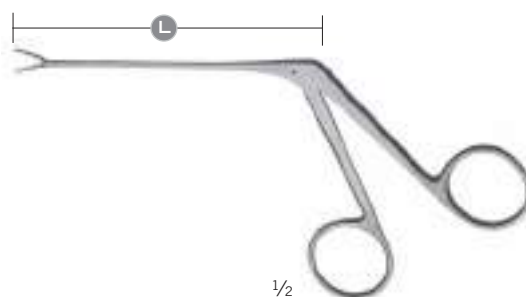

Drahtbiegezängchen
 Wire Bending Forceps
 Pinza para plegar alambre
 Pince à plier les fils d'acier
 Pinza per piegare fili metallici



1/2

McGee
 36-010-11-07 -
 36-010-12-07

Drahtbiegezängchen
 Wire Bending Forceps
 Pinza para plegar alambre
 Pince à plier les fils d'acier
 Pinza per piegare fili metallici

	abgewinkelt angled downward acodado abajo angulé vers le bas angolato verso il basso	abgewinkelt angled downward acodado abajo angulé vers le bas angolato verso il basso
1/1	 0,8 x 3,5 mm	 0,8 x 6,0 mm
L	8 cm	8 cm
SB	36-010-11-02	36-010-12-02
St	36-010-11-07	36-010-12-07

Mikro-Ohrzängchen

Micro Ear Forceps
 Micro pinzas auriculares
 Micro Pince auriculaires
 Micro Pinze auricolari

Otologie
 Otology
 Otología
 Otologie
 Otologia

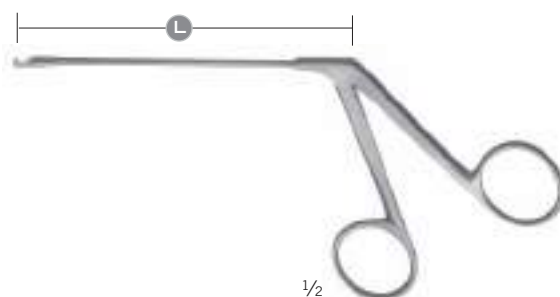
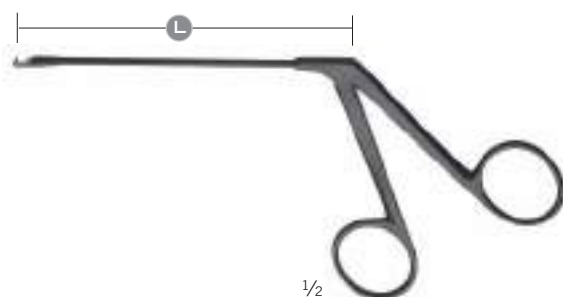
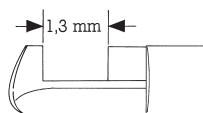
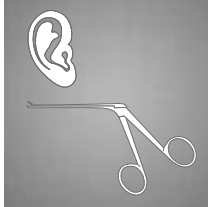

House-Dieter
 36-011-01-02 -
 36-011-07-02
 Hammerkopfzängchen
 Malleus Nipper
 Pinza para cabezal del maléolo
 Pince pour l'os marteau
 Pinza per testa del martelletto

House-Dieter
 36-011-01-07 -
 36-011-07-07
 Hammerkopfzängchen
 Malleus Nipper
 Pinza para cabezal del maléolo
 Pince pour l'os marteau
 Pinza per testa del martelletto

	oben schneidend up-cutting corte arriba tranchante en haut tagliente in alto	unten schneidend down-cutting corte abajo tranchante en bas tagliente in basso	rechts schneidend right-cutting corte derecho tranchant à droite tagliente a destra	links schneidend left-cutting corte izquierdo tranchant à gauche tagliente a sinistra
1/1				
L	9 cm	9 cm	9 cm	9 cm
SB	36-011-01-02	36-011-02-02	36-011-06-02	36-011-07-02
St	36-011-01-07	36-011-02-07	36-011-06-07	36-011-07-07

36

Mikro-Ohrzängchen

Micro Ear Forceps

Micro pinzas auriculares

Micro Pince auriculaires

Micro Pinze auricolari

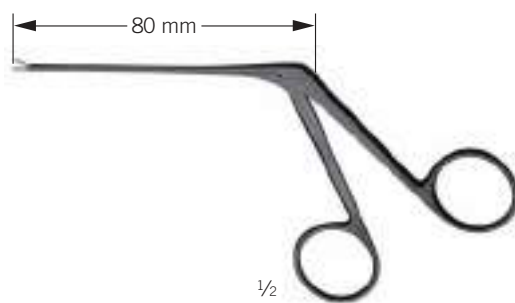
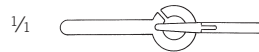

Fuller

36-013-01-02 

Einführungszängchen, für Teflonprothesen
Introducing Forceps, for teflon prosthesis
Pinza para introducir, para prótesis de teflon
Pince pour introduction, pour prothèse en téflon
Pinza per introduzione, per protesi in teflon

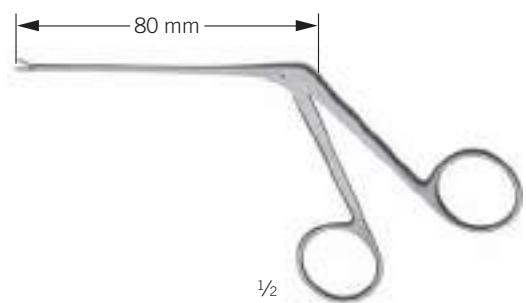

Fuller

36-013-01-07 

Einführungszängchen, für Teflonprothesen
Introducing Forceps, for teflon prosthesis
Pinza para introducir, para prótesis de teflon
Pince pour introduction, pour prothèse en téflon
Pinza per introduzione, per protesi in teflon

Mikro-Ohrmesser

Micro Ear Knives
 Micro cuchillos auriculares
 Micro Couteaux auriculaires
 Micro Coltelli

Otologie

Otology
 Otología
 Otologie
 Otologia

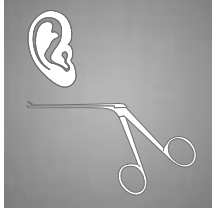

Schuknecht
 36-020-06-07
 14,5 cm / 5 7/8"
 Sichelmesser
 Sickle Knife
 Cuchillo de hoz
 Synéchiotome
 Coltello falcato
 come sinechia



Wullstein
 36-020-11-07
 15,5 cm / 6 1/8"
 Sichelmesser
 Sickle Knife
 Cuchillo de hoz
 Synéchiotome
 Coltello falcato
 come sinechia



Tabb
 36-020-16-07
 15,5 cm / 6 1/8"
 Schleimhautmesser
 Mucosa Knife
 Cuchillo para mucosa
 Couteau pour muqueuse
 Bisturi per mucosa



Plester
 36-020-21-07
 15 cm / 5 7/8"
 Lappenmesser
 Flap Knife
 Cuchillo para lóbulos
 Couteau lobaire
 Coltello per lobi

36



Rosen
 36-022-01-07 -
 36-022-07-07
 15 cm / 5 7/8"

36-022-01-07	Fig. 1	∅ 3,0 mm	
36-022-02-07	Fig. 2	∅ 2,8 mm	
36-022-03-07	Fig. 3	∅ 2,6 mm	
36-022-04-07	Fig. 4	∅ 2,0 mm	
36-022-05-07	Fig. 5	∅ 1,6 mm	
36-022-06-07	Fig. 6	∅ 1,4 mm	
36-022-07-07	Fig. 7	∅ 1,0 mm	

Mikro-Ohrhäkchen, Mikro-Ohrnadeln

Micro Ear Hooks, Micro Ear Needles

Micro ganchitos auriculares, Micro agujas auriculares

Micro Crochets auriculaires, Micro Aiguilles auriculaires

Micro Uncini auricolari, Micro Aghi auricolari

25° Haken hook gancho crochet gancio	45° Haken hook gancho crochet gancio	90° Haken hook gancho crochet gancio	
36-024-06-07 0,3 mm	36-024-11-07 0,3 mm	36-024-21-07 0,3 mm	36-024-31-07 0,5 mm
36-024-07-07 0,6 mm	36-024-12-07 0,6 mm	36-024-22-07 0,6 mm	36-024-32-07 1,0 mm
36-024-08-07 1,0 mm	36-024-13-07 1,0 mm	36-024-23-07 1,0 mm	
	36-024-14-07 1,2 mm	36-024-24-07 1,2 mm	
	36-024-15-07 1,5 mm	36-024-25-07 1,5 mm	
	36-024-16-07 2,0 mm	36-024-26-07 2,0 mm	
	36-024-17-07 2,5 mm	36-024-27-07 2,5 mm	

1/2

36-024-01-07 -
36-024-32-07
16 cm / 6 2/8"

Mikro-Ohrhäkchen, Mikro-Ohrnadeln

Micro Ear Hooks, Micro Ear Needles

Micro ganchitos auriculares, Micro agujas auriculares

Micro Crochets auriculaires, Micro Aiguilles auriculaires

Micro Uncini auricolari, Micro Aghi auricolari

Otologie

Otology

Otología

Otologie

Otologia

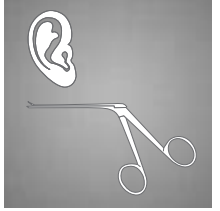

aufgewinkelt
bent upwards
angulado hacia arriba
coudé en haut
angolato in alto
90°

1/1

36-025-01-07	0,3 mm
36-025-02-07	0,6 mm
36-025-03-07	1,0 mm

abgewinkelt
angled
angulada
coudée
angolata
90°

36-025-06-07	0,3 mm
36-025-07-07	0,6 mm
36-025-08-07	1,0 mm

aufgebogen
bent upwards
angulado hacia arriba
coudé en haut
angolato in alto

McGee

36-027-01-07	0,5 mm
36-027-02-07	1,0 mm

für Fußplatte
for footplate
para la platina estapediense
pour la platine de l'étrier
per la piedistallo

abgewinkelt
angled
angulada
coudée
angolata

McGee

36-027-11-07	0,5 mm
36-027-12-07	1,0 mm

für Fußplatte
for footplate
para la platina estapediense
pour la platine de l'étrier
per la piedistallo

1/2

36-025-01-07 -
36-027-08-07
15,5 cm / 6 1/8"



1/2

Barbara
36-029-01-07 -
36-029-06-07
15,5 cm / 6 1/8"

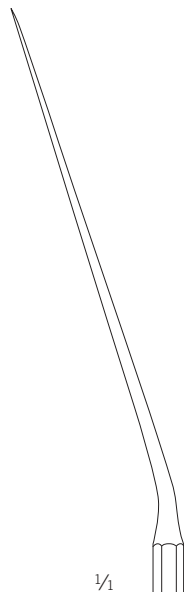

1/1

36-029-01-07

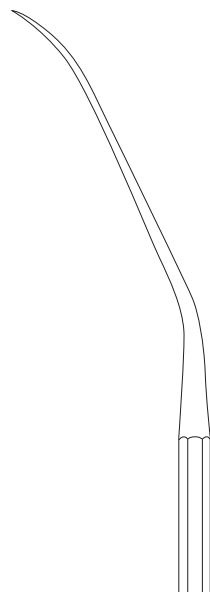

36-029-06-07

Mikro-Ohrhäkchen, Mikro-Dissektoren

Micro Ear Hooks, Micro Dissectors

Micro ganchitos auriculares, Micro disecadores

Micro Crochets auriculaires, Micro Dissecteurs

Micro Uncini auricolari, Micro Dissettori



	<p>25° Haken hook gancho crochet gancio 0,3 mm</p>	<p>25° Haken hook gancho crochet gancio 0,6 mm</p>	<p>25° Haken hook gancho crochet gancio 1,0 mm</p>	<p>45° Haken hook gancho crochet gancio 0,3 mm</p>
	<p>1/4</p> <p>36-030-06-07</p>	<p>36-030-07-07</p>	<p>Shambaugh 36-030-08-07</p>	<p>36-030-11-07</p>
	<p>45° Haken hook gancho crochet gancio 0,6 mm</p>	<p>45° Haken hook gancho crochet gancio 1,0 mm</p>	<p>45° Sondierhaken Exploring Hook Ganchito explorador Crochet à exploration uncino di sondaggio 2,0 mm stumpf blunt romo mousse smusso</p>	<p>90° Attikusdissektor Attic Dissector Disecador para el ático Dissecteur pour l'attique Dissetto per l'attico 3,0 mm stumpf blunt romo mousse smusso</p>
1/2	<p>36-030-06-07 - 36-030-30-07 15 cm / 5 7/8"</p>	<p>36-030-12-07</p>	<p>Shambaugh 36-030-13-07</p>	<p>Shea 36-030-20-07</p>
				<p>Austin 36-030-30-07</p>



	<p>1/4</p> <p>36-036-01-07 15 cm / 5 7/8" nach rechts abgewinkelt angled to right angulada por derecha coudée vers droite angulata a destra</p>	<p>36-036-02-07 15 cm / 5 7/8" nach links abgewinkelt angled to left angulada por izquierda coudée vers gauche angulata a sinistra</p>	<p>36-036-05-07 15,5 cm / 6 1/8" nach rechts abgewinkelt angled to right angulada por derecha coudée vers droite angulata a destra</p>	<p>36-036-06-07 15,5 cm / 6 1/8" nach links abgewinkelt angled to left angulada por izquierda coudée vers gauche angulata a sinistra</p>	<p>1/4</p> <p>1,2 mm</p>
1/2	<p>Fisch 36-036-01-07 - 36-036-06-07</p>				<p>Rosen 36-036-23-07 15 cm / 5 7/8" Mikro-Ohrspatorium Micro Ear Periosteal Elevator Micro Legra auricular Micro Rugine-Raspatoire auriculaire Micro Raspatore auricolare</p>

Mikro-Küretten, Mikro-Messsonden

Micro Currettes, Micro Measuring Rods
 Micro cucharillas, Micro Sondas para medir
 Micro Currettes, Micro Sondes pour mesurer
 Micro cucchiari, Micro Sonde per misurare

Otologie
 Otology
 Otología
 Otologie
 Otologia

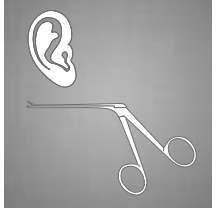

	1/4	1/4	1/4	1/4
	36-038-01-07	36-038-02-07	36-038-03-07	36-038-04-07
	Markierung bis Marking up to Manchar hasta Marquage jusque Marcatura fino a 3,5 mm	Markierung bis Marking up to Manchar hasta Marquage jusque Marcatura fino a 4,0 mm	Markierung bis Marking up to Manchar hasta Marquage jusque Marcatura fino a 4,5 mm	Markierung bis Marking up to Manchar hasta Marquage jusque Marcatura fino a 5,0 mm

1/2

House
 36-038-01-07 -
 36-038-04-07
 15,5 cm / 6 1/8"

	1/2	1/4	1/4	1/4
	∅ 1,0 mm	∅ 1,5 mm	∅ 1,0 mm	
	36-044-01-07	36-044-02-07	36-044-03-07	
	∅ 1,2 mm	∅ 1,8 mm	∅ 1,2 mm	

1/2

House
 36-044-01-07 -
 36-044-03-07
 14,5 cm / 5 9/16"

Ohrspekula

Ear Specula

Espéculos auriculares

Spéculums auriculaires

Specoli auricolari

St



1/2

1/1



Fig. 0	Fig. 1	Fig. 2	Fig. 3	Fig. 4
Ø 3,0 mm	Ø 4,0 mm	Ø 5,0 mm	Ø 6,0 mm	Ø 7,5 mm
36-112-10-01	36-112-11-01	36-112-12-01	36-112-13-01	36-112-14-01

Hartmann
36-112-03-01 -
36-115-04-01
3,6 cm / 1 3/8"

Fig. 0 - 2	Fig. 2 - 4	Fig. 1 - 4
36-112-03-01	36-114-03-01	36-115-04-01
Ohrspekula, Satz, Ear Specula, set Espéculos auriculares, juego Spéculums auriculaires, jeu Specoli auricolari, set für Kinder for children para niños pour enfants per bambini	Ohrspekula, Satz, Ear Specula, set Espéculos auriculares, juego Spéculums auriculaires, jeu Specoli auricolari, set für Erwachsene for adults para adultos pour adultes per adulti	Ohrspekula, Satz, Ear Specula, set Espéculos auriculares, juego Spéculums auriculaires, jeu Specoli auricolari, set für Erwachsene for adults para adultos pour adultes per adulti

St



1/2

1/1



Fig. 1	Fig. 2	Fig. 3	Fig. 4
Ø 4,0 mm	Ø 5,0 mm	Ø 6,0 mm	Ø 7,5 mm
36-118-11-01	36-118-12-01	36-118-13-01	36-118-14-01

Toynbee
36-118-03-01 -
36-119-04-01
3,6 cm / 1 3/8"

Fig. 2 - 4	Fig. 1 - 4
36-118-03-01	36-119-04-01
Ohrspekula, Satz, Ear Specula, set Espéculos auriculares, juego Spéculums auriculaires, jeu Specoli auricolari, set für Erwachsene for adults para adultos pour adultes per adulti	Ohrspekula, Satz, Ear Specula, set Espéculos auriculares, juego Spéculums auriculaires, jeu Specoli auricolari, set für Erwachsene for adults para adultos pour adultes per adulti

Ohrspekula

Ear Specula
Espéculos auriculares
Spéculums auriculaires
Specoli auricolari

Otologie

Otology
Otología
Otologie
Otologia

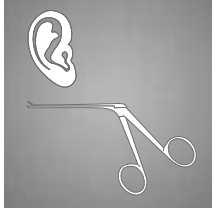

Al



Fig. 1	Fig. 2	Fig. 3	Fig. 4	Fig. 5	Fig. 6
5,5 x 6,5 mm	6,5 x 7,5 mm	7,5 x 8,5 mm	8,5 x 9,5 mm	9,5 x 10,5 mm	10,5 x 11,5 mm
36-132-01-04	36-132-02-04	36-132-03-04	36-132-04-04	36-132-05-04	36-132-06-04

Zöllner

36-132-00-04 -
36-132-06-04

3,8 cm / 1 4/8"
oval, schwarz
oval, black
ovalado, negro
ovale, noire
ovale, nero

Fig. 1 - 6

36-132-00-04

Ohrspekula, Satz,
Ear Specula, set
Espéculos auriculares, juego
Spéculums auriculaires, jeu
Specoli auricolari, set

St
18/6



Fig. 1	Fig. 2	Fig. 3	Fig. 4	Fig. 5	Fig. 6	Fig. 7
Ø 5,5 mm	Ø 6,5 mm	Ø 7,5 mm	Ø 8,5 mm	Ø 9,5 mm	Ø 10,5 mm	Ø 11,5 mm
36-134-01-07	36-134-02-07	36-134-03-07	36-134-04-07	36-134-05-07	36-134-06-07	36-134-07-07

Farrior

36-134-01-07 -
36-134-07-07

3,6 cm / 1 3/8"
rund, schwarz
round, black
redondo, negro
ronde, noire
rotondo, nero



36-148-12-01

Ohrspekulaständer
Ear Specula Storage Rack
Soporte para espéculos auriculares
Support pour spéculums auriculaires
Supporto per specoli auricolari

Stimmgabeln

Tuning Forks

Diapasónes

Diapasons

Diapason



1/2

French
36-170-07-04
C₂ 16



1/2

French
36-172-08-04
C₁ 32



1/2

Hartmann
36-174-09-04
C 64



1/2

Hartmann
36-175-10-04
C 128



1/2

Hartmann
36-177-11-04
C₁ 256

Stimmgabeln

Tuning Forks
Diapasónes
Diapasons
Diapason

Otologie

Otology
Otología
Otologie
Otologia



1/2

Martin
36-180-10-04 AI
C 128



1/2

Martin
36-182-11-04 AI
C 256



1/2

Martin-Alloy
36-184-12-04 AI
C 512



1/2

Martin-Alloy
36-186-13-04 AI
C 1024



1/2

Martin-Alloy
36-188-14-04 AI
C 2048

36



1/2

Hartmann
36-189-10-04
C 128



1/2

Hartmann
36-192-11-04
C¹ 256



1/2

Hartmann
36-194-12-04
C² 512



1/2

Hartmann
36-196-13-04
C³ 1024



1/2

Hartmann
36-198-14-04
C⁴ 2048



1/2

Hartmann
36-200-15-04
C⁵ 4096

Stimmgabeln

Tuning Forks

Diapasónes

Diapasons

Diapason



Lucae
36-210-10-04
C 128

1/2



Lucae
36-212-11-04
C1 256

1/2



Lucae
36-214-12-04
C2 512

1/2



Lucae
36-216-13-04
C3 1024

1/2



Lucae
36-218-14-04
C4 2048

1/2



Lucae
36-220-15-04
C5 4096

36-216-90-98

Fuss, allein
Socket, only
Pedestal, suelto
Socle, seul
Zoccolo, solo

1/2



1/1

36-221-91-98

Fuss, allein
Socket, only
Pedestal, suelto
Socle, seul
Zoccolo, solo

1/2

Lucae
36-221-10-04 - 36-221-91-98

C 128

verschiebbar bis h
moveable up to h
regulable hasta h
réglable jusqu'à h
regolabile fino a h

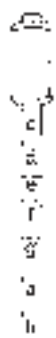

1/1

1/2

Hartmann
36-222-10-04

C 128

verschiebbar bis h
moveable up to h
regulable hasta h
réglable jusqu'à h
regolabile fino a h

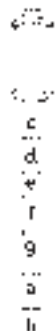

1/2

36-223-90-98

Fuss, allein
Socket, only
Pedestal, suelto
Socle, seul
Zoccolo, solo

Hartmann
36-223-11-04 - 36-223-90-98

C1 256

Stimmgabeln

Tuning Forks
Diapasones
Diapasons
Diapason

Otologie

Otology
Otología
Otologie
Otologia



36-224-90-98

Dämpfer
Dampfer
Sordina
Curseur
Sordina
weiße Skala
white scale
balanza blanca
l'échelle graduée blanche
scala bianca



36-224-10-04

36-224-91-98

Dämpfer
Dampfer
Sordina
Curseur
Sordina
schwarze Skala
black scale
balanza negra
l'échelle graduée noire
scala nera



36-224-10-04

36-224-92-98

Rändelschraube
Knurled screw
Tornillo moleteado
Vis moletée
Vite a
testa zigrinata



36-224-10-04

36-224-93-98

Gewichte, C 64
Weights, C 64
Pesas, C 64
Poids, C 64
Pesi, C 64



36-224-10-04



1/2

Rydell-Seiffert
36-224-10-04
C 64 / c 128

auch für Neurologie
also for neurology
también para neurología
aussi pour la neurologie
anche per neurologia



1/2

Neuro
36-226-00-04

mit Hammer, Nadelrad, Pinsel und Nadel
with hammer, pinwheel, brush and needle
con martillo, rueda con espinas, cepillo y aguja
avec marteaux, roue aux épingles, brosette et aiguille
con martello, aligesimetro, pennello ed ago

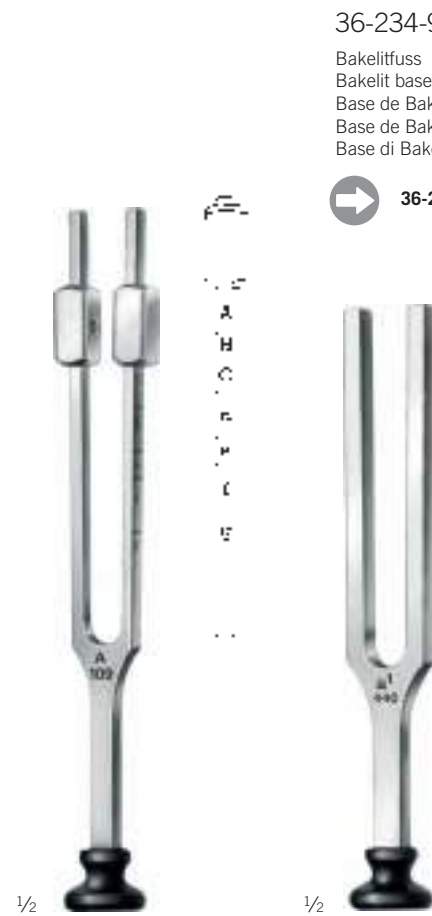

1/2

König
36-230-59-04
A 109

verschiebbar bis g
moveable up to g
regulable hasta g
réglable jusqu'à g
regolabile fino a g

1/2

36-234-61-04
a¹ 440



36-234-61-04

36-234-90-98

Bakelitfuss
Bakelit base
Base de Bakelit
Base de Bakelit
Base di Bakelit

Ohrkatheter, Polypenschnürer

Ear Catheters, Polypus Snares
 Sondas auriculares, Polipótomos
 Sondes auriculaires, Serre-noeuds
 Sonde auricolari, Serranodi



1/1



Fig. 1	Fig. 2	Fig. 3
Ø 3,0 mm	Ø 3,5 mm	Ø 4,0 mm
36-321-01-01	36-321-02-01	36-321-03-01

1/2

Hartmann
 36-321-01-01 -
 36-321-03-01
 15 cm / 5 7/8"



1/2

36-316-11-07
 Schaftlänge
 shaft length
 longitud del vástago
 longueur de la tige
 lunghezza dell'asta
110 mm



1/1

1/2

Krause
 36-351-16-07
 18,5 cm / 7 3/8"
 offenes Ende
 open tip
 punta abierta
 pointe ouverte
 punta aperta



1/1

1/2

Krause-Voss
 36-353-16-07
 18,5 cm / 7 3/8"
 geschlossenes Ende
 closed tip
 punta cerrada
 pointe fermée
 punt chiusa

36-353-90-98

Polypenschnürer
 Polypus Snares
 Polipótomos
 Serre-noeuds
 Serranodi



36-353-16-07

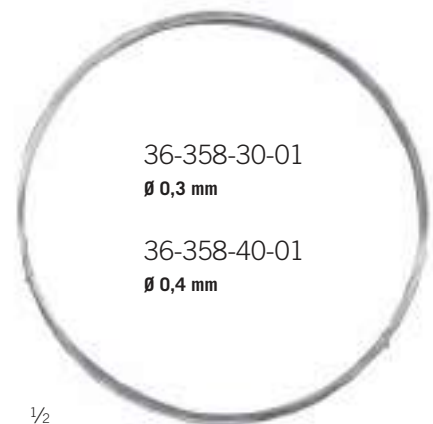

1/2

36-358-30-01
 Ø 0,3 mm

36-358-40-01
 Ø 0,4 mm

36-358-30-01 -
 36-358-40-01



36-351-16-07,
 36-353-16-07

Schnürdraht, Rolle mit 10 m
 Snare Wire, coil of 10 m
 Alambre, rollo de 10 m
 Serre-noeuds, en rouleaux de 10 m
 Filo in acciaio, rotolo di 10 m

Ohrpinzetten

Ear Forceps
Pinzas auriculares
Pincès auriculaires
Pinze auricolari

Otologie

Otology
Otología
Otologie
Otologia



Tröltzsch (Wilde)
36-371-11-07
10,5 cm / 4 $\frac{1}{8}$ "



Tröltzsch (Wilde)
36-375-12-07
11 cm / 4 $\frac{3}{8}$ "



Tröltzsch (Wilde)
36-381-13-07
12,5 cm / 4 $\frac{7}{8}$ "

36



Grünwald
36-391-14-07
14,5 cm / 5 $\frac{5}{8}$ "



Jansen
36-395-16-07
16 cm / 6 $\frac{2}{8}$ "
36-395-20-07
21,5 cm / 8 $\frac{4}{8}$ "

Ohrpolypenzangen

Ear Polypus Forceps

Pinzas para pólipos auriculares

Pinces pour polypes auriculaires

Pinze per polipi auricolari

1/1



1/2

Hartmann
36-405-12-07

feines Modell	Schaftlänge
delicate pattern	shaft length
modelo delicado	longitud del vástago
modèle fin	longueur de la tige
modello fino	lunghezza dell'asta
	65 mm

1/1



1/2

Hartmann
36-407-14-07

normales Modell	Schaftlänge
regular model	shaft length
modelo regular	longitud del vástago
modèle normal	longueur de la tige
modello normale	lunghezza dell'asta
	65 mm

1/1



1/2

Buck
36-416-11-07

11,5 cm / 4 5/8"
Fremdkörperzängchen
Foreign Body Lever
Elevador para cuerpos extraños
Pince pour polypes auriculaires
Pinza per corpi estranei

1/1



1/2

Quire
36-418-10-07

10,5 cm / 4 1/8"
Fremdkörperheber
Foreign Body Lever
Elevador para cuerpos extraños
Pince pour corps étrangers
Leva per corpi estranei

Ohrpolypenzangen

Ear Polypus Forceps
 Pinzas para pólipos auriculares
 Pincas pour polypes auriculaires
 Pinze per polipi auricolari

Otologie
 Otology
 Otología
 Otologie
 Otologia

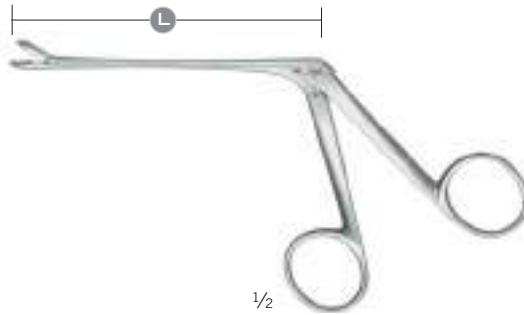
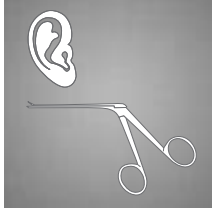

36-425-08-07 -
 36-456-08-07

	Hartmann-Wullstein	Hartmann-Wullstein
1/1		
L	8,5 cm	8,5 cm
	36-425-08-07	36-427-08-07

	Hartmann	Hartmann	Hartmann
1/1			
L	8,5 cm	14 cm	8,5 cm
	36-430-08-07	36-430-14-07	36-431-08-07

	Hartmann-Herzfeld	Hartmann-Herzfeld	Hartmann-Herzfeld
1/1	 ○ Ø 2,0 mm	 ○ Ø 2,5 mm	 ○ Ø 3,0 mm
L	8,5 cm	8,5 cm	8,5 cm
	36-442-81-07	36-442-82-07	36-442-83-07

	Hartmann-Wullstein	Strümpel	Hartmann-Hoffmann durchschneidend through-cutting cortante tranchante tagliante
1/1	 ○ Ø 3,0 mm		 Ø 2,0 mm
L	8,5 cm	8,5 cm	8,5 cm
	36-445-08-07	36-448-08-07	36-456-08-07

Ohr-Knochenstanzen

Mastoid Rongeurs

Pinzas cortantes para huesos

Ostéotomes emporte-pièces

Pinze osteotomi



Citelli
36-461-17-07

Maulbreite Jaw width Anchura de la boca Largeur de mors Larghezza della bocca	aufgewinkelt angled upward acodado arrib angulé vers le haut angolato verso l'alto
3 mm	L 7,5 cm
	36-461-17-07

Ohr-Knochenstanzen

Mastoid Rongeurs
 Pinzas cortantes para huesos
 Ostéotomes emporte-pièces
 Pinze osteotomi

Otologie

Otology
 Otología
 Otologie
 Otologia

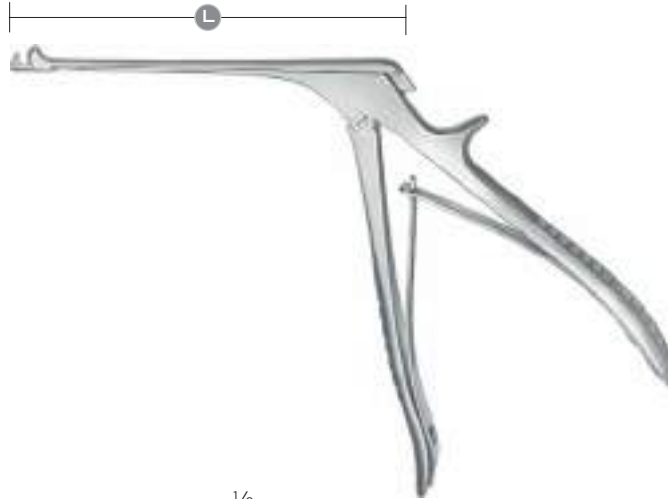
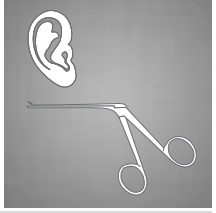

1/2

Beyer
 36-463-19-07 -
 36-466-14-07

36

Maulbreite Jaw width Anchura de la boca Largeur de mors Larghezza della bocca		aufgewinkelt angled upward acodado arrib angulé vers le haut angolato verso l'alto
		1/1
		L 9,5 cm
1 mm		36-466-14-07
2 mm		36-463-19-07

Ohrküretten

Ear Curettes

Curetas auriculares

Curettes auriculaires

Curette auricolari



Langenbeck
36-491-13-07
13 cm / 5 1/8"
stumpf
blunt
romo
mousse
smusso

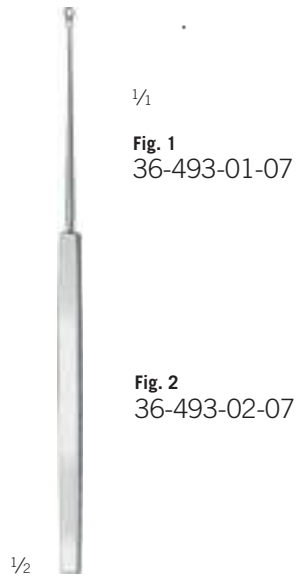

Shapleigh
36-493-01-07 -
36-493-02-07
15 cm / 5 7/8"



Buck
36-495-02-07 -
36-495-12-07
17 cm / 6 5/8"
stumpf
blunt
romo
mousse
smusso



Buck
36-497-01-07 -
36-498-14-07
15 cm / 6 5/8"

36-495-02-07	Fig. 00	Ø 2,1 mm
36-495-10-07	Fig. 0	Ø 2,6 mm
36-495-11-07	Fig. 1	Ø 3,2 mm
36-495-12-07	Fig. 2	Ø 3,7 mm

stumpf blunt romo mousse smusso		
36-497-01-07	Fig. 000	Ø 1,8 mm
36-497-02-07	Fig. 00	Ø 2,1 mm
36-497-10-07	Fig. 0	Ø 2,6 mm
36-497-11-07	Fig. 1	Ø 3,2 mm
36-497-12-07	Fig. 2	Ø 3,7 mm
36-497-13-07	Fig. 3	Ø 4,1 mm
36-497-14-07	Fig. 4	Ø 4,4 mm

scharf sharp agudo pointu acuto		
36-498-01-07	Fig. 000	Ø 1,8 mm
36-498-02-07	Fig. 00	Ø 2,1 mm
36-498-10-07	Fig. 0	Ø 2,6 mm
36-498-11-07	Fig. 1	Ø 3,2 mm
36-498-12-07	Fig. 2	Ø 3,7 mm
36-498-13-07	Fig. 3	Ø 4,1 mm
36-498-14-07	Fig. 4	Ø 4,4 mm

Ohrlöffel, Fremdkörperinstrumente

Ear Scoop, Foreign Body Instruments

Cucharilla auricular, Instrumentos para cuerpos extraños

Curette auriculaire, Instruments pour corps étrangers

Curetta auricolare, Strumenti per corpi estranei

Otologie

Otology

Otología

Otologie

Otologia

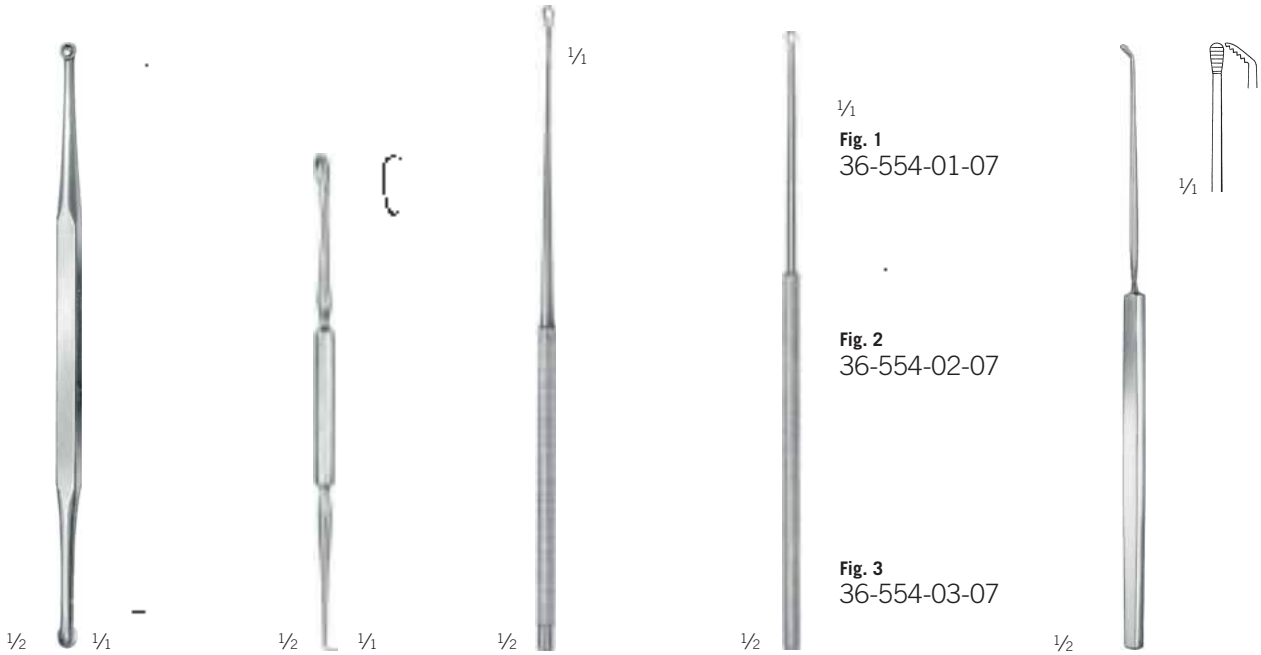
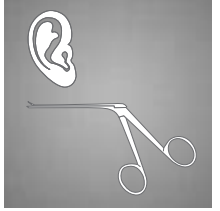

Jansen
36-532-15-07

16 cm / 6 ²/₈"

scharf
sharp
agudo
pointu
acuto

Gross
36-543-12-07

13 cm / 5 ¹/₈"

stumpf
blunt
romo
mousse
smusso

Weber-Loch
36-551-01-07

17 cm / 6 ⁶/₈"

Billeau
36-554-01-07 -
36-554-03-07

16,5 cm / 6 ⁴/₈"

Moldenhauer
36-561-16-07

16 cm / 6 ¹/₈"

Fremdkörperhebel
Foreign Body Lever
Elevador para cuerpos extraños
Anse auriculaire
Leva per corpi estranei

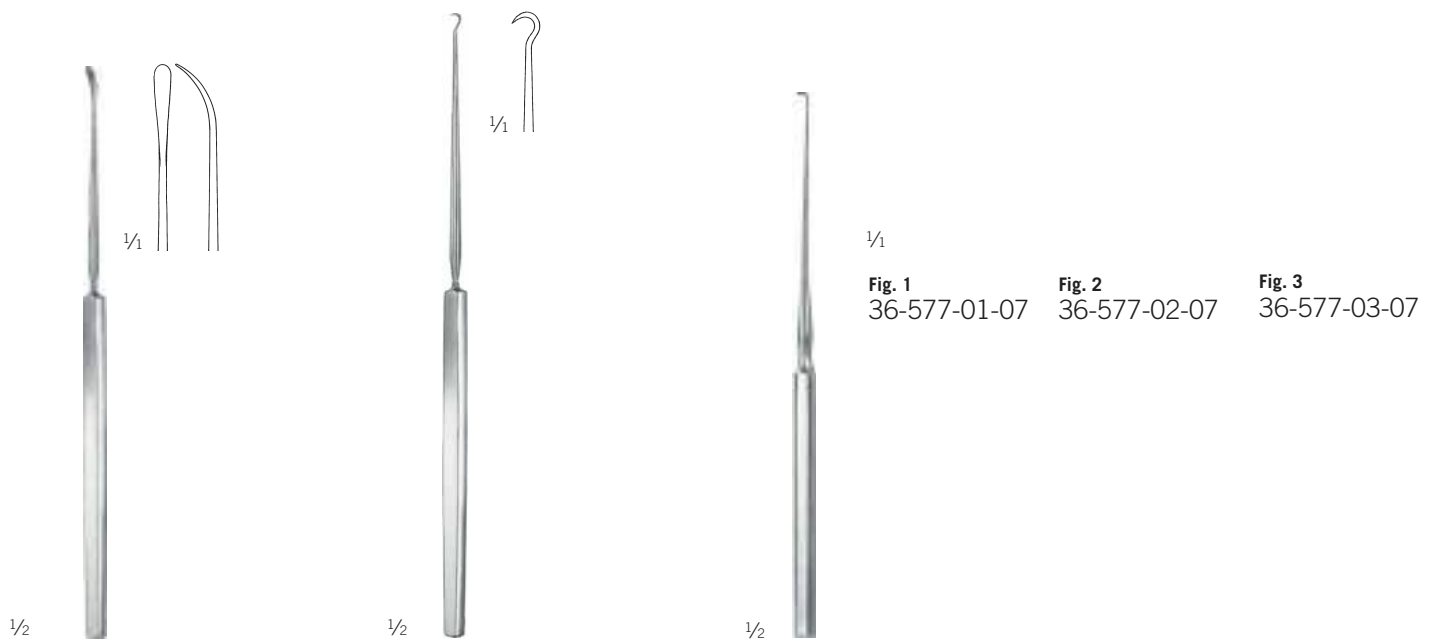

Zaufal
36-563-16-07

15 cm / 5 ⁷/₈"

Fremdkörperhebel
Foreign Body Lever
Elevador para cuerpos extraños
Anse auriculaire
Leva per corpi estranei

Hartmann
36-570-16-07

16 cm / 6 ²/₈"

Ohrhäkchen
Ear Hooklet
Ganchito auricular
Levier pour corps étrangers
Uncino auricolare

Lucae
36-577-01-07 -
36-577-03-07

14 cm / 5 ⁴/₈"

36

Ohrhäkchen, Trommelfellnadeln

Ear Hooklet, Tympanum Needles

Ganchito auricular, Agujas para tímpano

Levier pour corps étrangers, Instruments pour corps étrangers

Uncino auricolare, Strumenti per corpi estranei

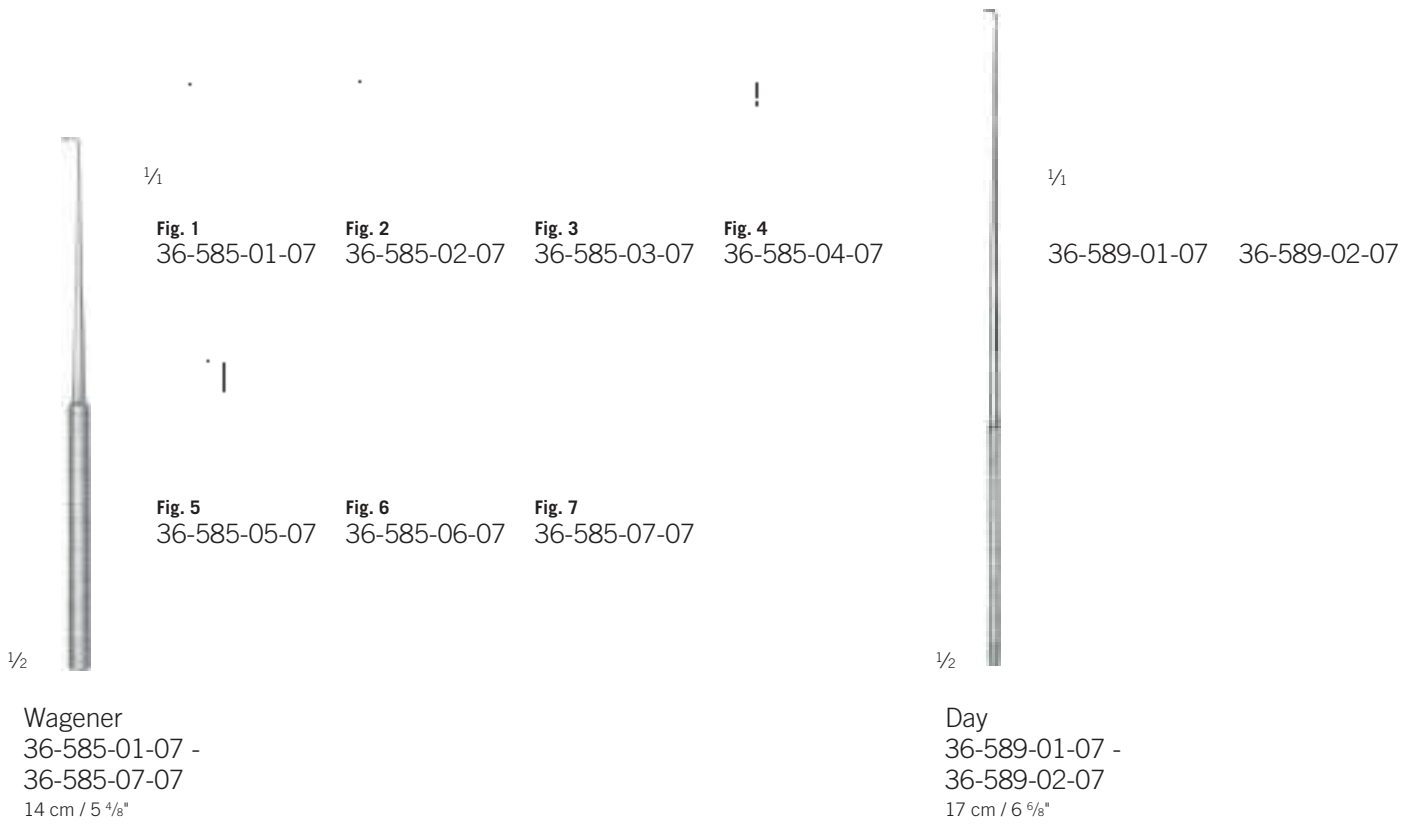

Ohrraspatorien, Ohrlöffel

Ear Periosteal Elevators, Ear Scoop

Legras auriculares, Cucharilla auricular

Rugines-raspatoires auriculaires, Rugine-raspatoire auriculaire

Raspatori auricolari, Curetta auricolare

Otologie

Otology

Otología

Otologie

Otologia



1/1

Fig. 5
36-743-50-07

Fig. 4
36-743-40-07

Fig. 3
36-743-30-07

Fig. 2
36-743-20-07

Fig. 1
36-743-10-07



Lempert
36-737-20-07
20,5 cm / 8 1/8"



Lempert
36-739-17-07
18 cm / 7 1/8"



Lempert
36-743-10-07 -
36-743-50-07
21,5 cm / 8 4/8"
scharf
sharp
agudo
pointu
acuto

Pulverbläser

Atomizers
Pulverizadores
Lance-poudre
Insoffiatore

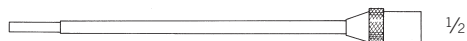

36-780-11-01

11 cm / 4"
Ohrkanüle
Ear Cannula
Cánula auricular
Canule auriculaire
Cannula auricolare

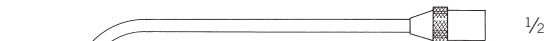

36-780-13-01

13 cm / 5"
Ohrkanüle, gebogen
Ear Cannula, curved
Cánula auricular, curva
Canule auriculaire, courbe
Cannula auricolare, courbe

36-780-90-98

Dichtungsring
Washer
Lavadora
Lessiveuse
Guarnizione ad anello

36-780-91-98

Mittelteil mit Ball
Middle part with ball
Partie centrale avec balle
Parte centrale con palla

36-780-08-01

8 cm / 3"
Ohrkanüle
Ear Cannula
Cánula auricular
Canule auriculaire
Cannula auricolare



1/2

36-780-01-04

Ersatzflasche
Spare Bottle
Frasco suelto
Flacon de rechange
Bottiglia di ricambio
30 ccm

36-780-92-98

Pulverbläser
Atomizer
Pulverizador
Lance-poudre
Insoffiatore polvere

36-780-50-04

Ventilball
Valve Rubber Bulb
Pera de goma con valva
Poire en caoutchouc avec valve
Pallone in gomma con valva

Kabierske

36-780-00-01

komplett mit 3 Kanülen und Gummiball
complete with 3 cannulas and rubber bulb
completo con 3 cánulas y pera de goma
complet avec 3 canules et poire en caoutchouc
completo con 3 cannule e pera di gomma



360°

1/1

1/2

Universal

36-786-00-02

komplett mit beweglicher Düse, Schraubflasche
30 ccm und Halbgebläse
complete with movable tube, screw bottle 30 ccm
and rubber bulb
completo con tubo móvil botella con rosca 30 ccm
y pera de goma
complet avec tuyère mobile, flacon fileté 30 ccm
et poire en caoutchouc
completo con tubo mobile, bottiglia con filettatura
30 ccm e pera di gomma

Universal

36-786-01-02

wie Art.-Nr. 36-786-00-02
jedoch ohne Gebläse
as ref. 36-786-00-02
but without rubber bulb
como ref. 36-786-00-02
pero sin pera de goma
comme réf. 36-786-00-02
mais sans poire en caoutchouc
come rif. 36-370-00-02
però senza pera di gomma

37-851-05-04

Gebläse, allein
rubber bulb, only
pera de goma, suelto
poire en caoutchouc, seul
pera di gomma, solo

Luftduschen

Air Bags
 Insufladores de aire
 Insufflateur d'air
 Insuffiatore d'aria

Otologie

Otology
 Otolología
 Otológia
 Otológia



1/2

36-792-03-02

Einsteckkonus
 Connecting Nozzle
 Cono de conexión
 Embout conique de raccordement
 Cono di connessione



1/2

36-792-04-02

Ohrolive
 Ear Olive
 Oliva auricular
 Olive auriculaire
 Oliva auricolare

Ø 4 mm



1/2

36-792-15-02

Nasenolive
 Nose Olive
 Oliva nasal
 Olive nasale
 Oliva nasale

Ø 15 mm



1/2

36-792-17-02

Nasenolive
 Nose Olive
 Oliva nasal
 Olive nasale
 Oliva nasale

Ø 17 mm



1/2

36-792-22-02

Nasenolive
 Nose Olive
 Oliva nasal
 Olive nasale
 Oliva nasale

Ø 22 mm



1/2

36-792-50-04

Gummibirne
 Rubber Bulb
 Pera de goma
 Poire en caoutchouc
 Pera in gomma



1/2

Politzer
 36-792-00-02

komplett mit 3 Nasenoliven
 Art.-Nr. 36-792-15-02 bis 36-792-22-02
 complete with 3 nasal olives
 ref. 36-792-15-02 to 36-792-22-02
 completo con 3 olivas nasales
 ref. 36-792-15-02 a 36-792-22-02
 complet avec 3 olives nasales
 réf. 36-792-15-02 jusqu'à 36-792-22-02
 completo con 3 olive nasali
 rif. 36-792-15-02 fino a 36-792-22-02

Politzer
 36-792-01-02

wie Art.-Nr. 36-792-00-02
 mit zusätzlicher Ohrolive Art.-Nr. 36-792-04-02
 as ref. 36-792-00-02
 with additional ear olive ref. 36-792-04-02
 como ref. 36-792-00-02
 con oliva auricular adicional ref. 36-792-04-02
 comme réf. 36-792-00-02
 avec olive auriculaire supplémentaire réf. 36-792-04-02
 come rif. 36-792-00-02
 con oliva auricolare supplementare rif. 36-792-04-02

Politzer
 36-792-02-02

wie Art.-Nr. 36-792-01-02
 in Kunststoffbox
 as ref. 36-792-01-02
 in plastic box
 como ref. 36-792-01-02
 en caja plástica
 comme réf. 36-792-01-02
 en boîte en matière plastique
 come rif. 36-792-01-02
 in contenitore di plastica

Ohrspritzen

Ear Syringes
 Jeringas auriculares
 Seringues auriculaires
 Siringhe auricolari



1/2

36-794-00-02

komplett, selbstfüllend
 in Kunststofftasche
 complete, self filling
 in plastic pouch
 completo, auto-rellena
 en bolsa plástica
 comple, à remplissage automatique
 en pochette en matière plastique
 completo, auto-riempente
 in borsa di plastica



1/2

36-794-03-04

Verbindungsschlauch
 Flexible Tube
 Tubo de conexión
 Tube de connection
 Tubo di connessione

36-794-90-98

Gummidichtung
 Rubber gasket
 Junta de goma
 Joint de caoutchouc
 Guarnizione di gomma



1/2

36-794-02-02

Ventilaufsatz
 Valve Attachment
 Válvula de conexión
 Soupape
 Valvola di connessione



1/2

36-794-04-02

Saugansatz
 Suction Nozzle
 Pieza de succión
 Embout à aspiration
 Aspiratore



1/2

36-794-05-02

Schutzteller
 Protecting Disc
 Disco protector
 Plaque de protection
 Disco protettivo

36-794-91-98

Rückhaltefeder
 Retention spring
 Muelle de retención
 Ressort de rétention
 Molla di ritenzione



1/2

36-794-06-02

Metalolive
 Metal Olive
 Oliva metálica
 Olive en métal
 Oliva in metallo



1/2

36-794-07-02

Konischer Ansatz
 Conical Tip
 Punta cónica
 Pointe conique
 Punta conica



1/2

36-794-08-02

Geknöpfter Ansatz
 Button ended Tip
 Punta de botón
 Pointe boutonnée
 Punta a bottone



1/2

36-794-09-02

Gewindeansatz
 Threaded Tip
 Punta de rosca
 Pointe filetée
 Punta filettata

36-795-01-02

Spritze, allein, 10 ml
 Syringe, only, 10 ml
 Jeringa, suelto, 10 ml
 Seringue, seul, 10 ml
 Siringa, solo, 10 ml

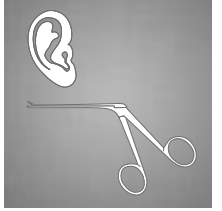

36-795-91-98
Spülansatz
Irrigation adapter
Adaptador de irrigación
Adaptateur à irrigation
Adattatore per lavaggio



36-795-92-98
Spülansatz
Irrigation adapter
Adaptador de irrigación
Adaptateur à irrigation
Adattatore per lavaggio



36-795-00-02
50 ml
komplett mit Teller und 2 Ansätzen
complete with protection disc and 2 tips
completo con disco protector y 2 puntas
complet avec plaque de protection et 2 pointes
completo con disco protettivo e 2 punte

36-795-90-98
Ohrspritze
Ear Syringe
Jeringa auricular
Seringue auriculaire
Siringa auricolare

36-795-04-02
100 ml
komplett mit Teller und 2 Ansätzen
complete with protection disc and 2 tips
completo con disco protector y 2 puntas
complet avec plaque de protection et 2 pointes
completo con disco protettivo e 2 punte

Nasenspekula

Nasal Specula
Espéculos nasales
Spéculums nasaux
Specoli nasali

1/1



1/2

Fig. 1
36-817-01-01
Blätter
blades
hojas
lames
lame
18,5 x 9,5 mm

Fig. 2
36-817-02-01
Blätter
blades
hojas
lames
lame
21,0 x 10,5 mm

Fig. 3
36-817-03-01
Blätter
blades
hojas
lames
lame
21,0 x 11,5 mm

Goldsmith (Thudichum)
36-817-01-01 -
36-817-03-01
6,5 cm / 2 1/8"

1/1



1/2

Fig. 1
36-845-01-07
Blätter
blades
hojas
lames
lame
27 mm

Fig. 2
36-845-02-07
Blätter
blades
hojas
lames
lame
31 mm

Fig. 3
36-845-03-07
Blätter
blades
hojas
lames
lame
35 mm

Hartmann-Halle
36-845-01-07 -
36-845-03-07
16 cm / 6 3/8"

Nasenspekula

Nasal Specula
Espéculos nasales
Spéculums nasaux
Specoli nasali

Otologie

Otology
Otología
Otologie
Otologia

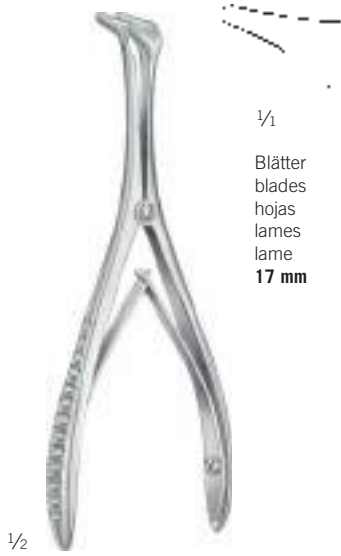

1/1
Blätter
blades
hojas
lames
lame
17 mm

1/2

Martin
36-848-13-07
13 cm / 5 1/8"



1/1
Blätter
blades
hojas
lames
lame
17 mm

1/2

Martin
36-849-13-07
13 cm / 5 1/8"



1/1
Blätter
blades
hojas
lames
lame
16 mm

1/2

Tieck-Halle
36-852-13-07
13 cm / 5 1/8"



1/2

Killian
36-856-01-07 -
36-856-04-07

1/1

Fig. 1
36-856-01-07
14 cm / 5 4/8"
Blätter
blades
hojas
lames
lame
35 mm

Fig. 2
36-856-02-07
14,5 cm / 5 6/8"
Blätter
blades
hojas
lames
lame
50 mm

Fig. 3
36-856-03-07
16 cm / 6 2/8"
Blätter
blades
hojas
lames
lame
75 mm

Fig. 4
36-856-04-07
17 cm / 6 6/8"
Blätter
blades
hojas
lames
lame
85 mm

Nasenspekula

Nasal Specula

Espéculos nasales

Spéculums nasaux

Specoli nasali



1/2

Mod. Wien
36-858-14-07
13,5 cm / 5 3/8"

1/1

Blätter
blades
hojas
lames
lame
30 mm



1/2

Cottle
36-859-35-07 -
36-859-90-07

1/1

Fig. 1
36-859-35-07
13,5 cm / 5 3/8"
Blätter
blades
hojas
lames
lame
35 mm

Fig. 2
36-859-50-07
14 cm / 5 4/8"
Blätter
blades
hojas
lames
lame
50 mm

Fig. 3
36-859-75-07
16 cm / 6 2/8"
Blätter
blades
hojas
lames
lame
75 mm



Fig. 4
36-859-90-07
16 cm / 6 2/8"
Blätter
blades
hojas
lames
lame
85 mm

Nasenspekula

Nasal Specula
Espéculos nasales
Spéculums nasaux
Specoli nasali

Otologie

Otology
Otología
Otologie
Otologia

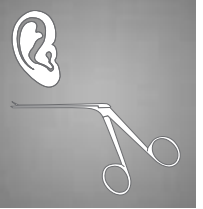

1/1

36-861-45-07

14 cm / 5 4/8"

Blätter
blades
hojas
lames
lame
45 mm

36-861-75-07

15,5 cm / 6 1/8"

Blätter
blades
hojas
lames
lame
75 mm

1/2



Cottle

36-861-45-07 -
36-861-75-07

schwarz
black
negro
noir
nero

Polypenschnürer

Polypus Snares

Polipótomos

Serre-noeuds pour polypes

Serranodi per polipi



Krause
36-885-26-07

26 cm / 10 ²/₈"

Schaft
shaft
vástago
tige
asta

Krause-Voss
36-887-26-07

26 cm / 10 ²/₈"

Schaft
shaft
vástago
tige
asta

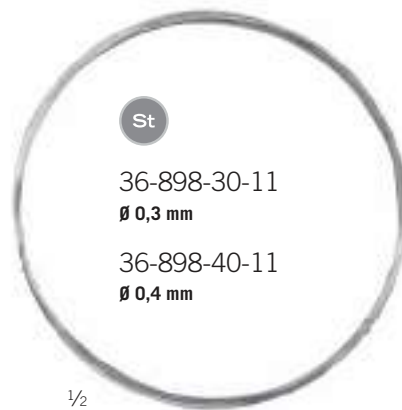

St

36-898-30-11

Ø 0,3 mm

36-898-40-11

Ø 0,4 mm

1/2



St

1/2

36-898-30-11 -
36-898-40-11

Schnürdraht
Snare Wire
Asa de alambre
Anse en fil d'acier
Filo per allacciare

Rolle mit 10 m
coil of 10 m
rollo de 10 m
en rouleaux de 10 m
rotolo di 10 m

36-899-12-01

10,5 cm / 4"

Schnürdraht
Snare Wire
Asas de alambre
Anses en fil d'acier
Filo per allacciare
0,3 mm Ø

Bündel mit 12 Stück
bundle with 12 pieces
12 piezas atados
paquet de 12 pièces
confezione di 12 pezzi

Rhinologie
Rhinology
Rinología
Rhinologie
Rinologia

37

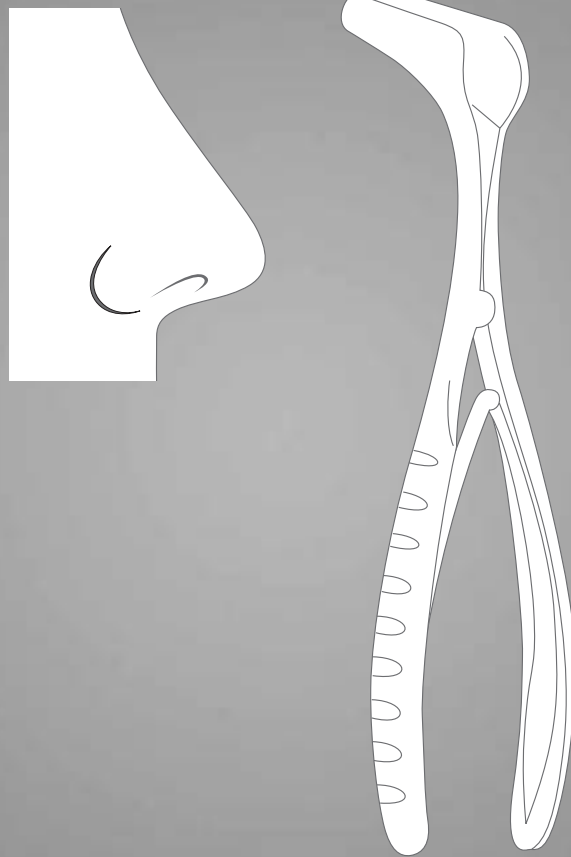

Nasentamponpinzetten, Nasentamponzangen

Nasal Tampon Forceps, Nasal Tampon Forceps
 Pinzas para taponamiento, Pinzas para taponamiento
 Pincès à pansements, Pincès à pansements
 Pinze per medicature, Pinze per medicature

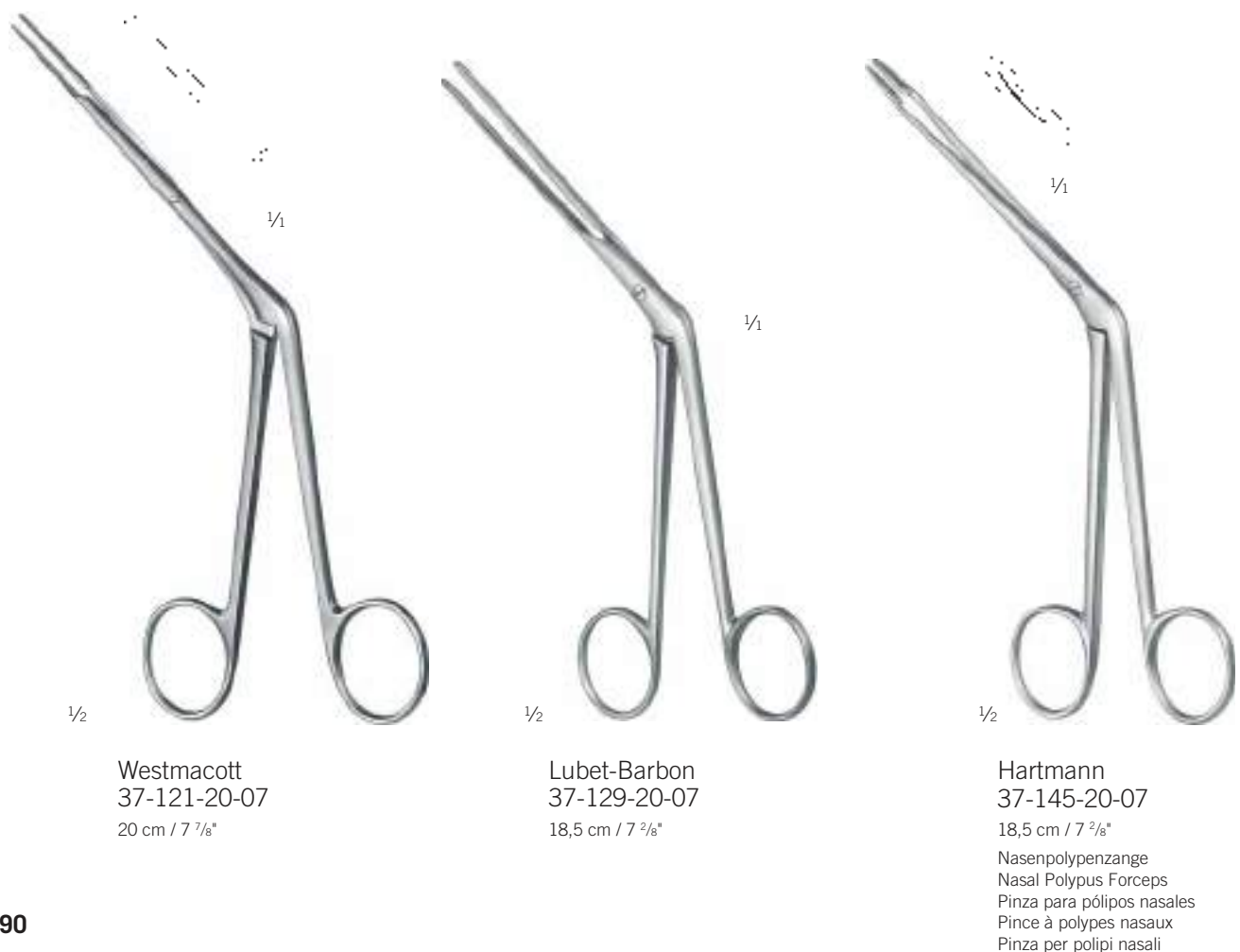

Septumzangen

Septum Forceps

Pinzas para tabique nasal

Pinces pour la cloison nasale

Pinze per il setto nasale

Rhinologie

Rhinology

Rinología

Rhinologie

Rinologia

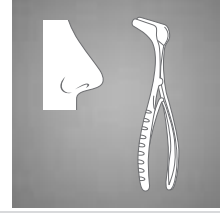

Knight
37-207-18-07
17 cm / 6 5/8"



Graig
37-213-18-07
16 cm / 6 2/8"

37



37-215-01-07
links gebogen
left curved
curvo por izquierdo
courbé à gauche
curvo a sinistra



37-215-02-07
rechts gebogen
right curved
curvo por derecho
courbé à droite
curvo a destra

37-215-01-07 -
37-215-02-07
15,5 cm / 6 1/8"



Brünings
37-227-01-07 -
37-227-04-07
16,5 cm / 6 4/8"



Fig. 1
37-227-01-07



Fig. 2
37-227-02-07



Fig. 3
37-227-03-07



Fig. 4
37-227-04-07

Siebbeinzangen

Ethmoid Bone Forceps

Pinzas para etmoides

Pinces éthmoïdales

Pinze etmoidali

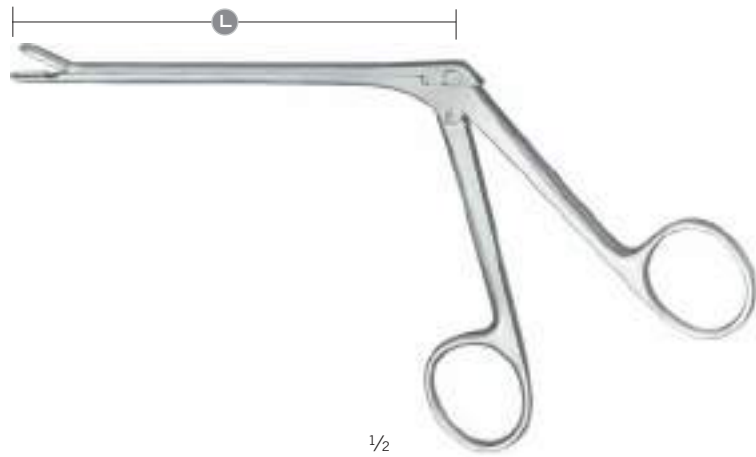

Takahashi
37-235-12-07 -
37-237-12-07

Maulbreite Jaw width Anchura de la boca Largeur de mors Larghezza della bocca		gerade straight recto droit diritto	45° aufgewinkelt angled upward acodado arrib angulé vers le haut angolato verso l'alto
	$\frac{1}{1}$		
	L	12 cm	12 cm
3,5 mm		37-235-12-07	37-237-12-07

Siebbeinzangen

Ethmoid Bone Forceps
 Pinzas para etmoides
 Pincas étmoidales
 Pinze etmoidali



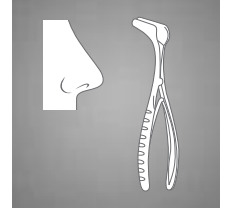

Rhinologie

Rhinology
 Rinología
 Rinologie
 Rinologia

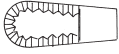

37-241-10-07 -
 37-249-12-07

37

Maul Jaw Boca Mors Bocca		gerade straight recto droit diritto	gerade straight recto droit diritto	gerade straight recto droit diritto
	$\frac{1}{1}$			
		Watson-Williams		Weil
	L	12 cm	12 cm	12 cm
	37-241-10-07			
		37-241-12-07		
			37-249-12-07	

Scharfe Nasenzangen, Siebbeinzangen

Nasal Cutting Forceps, Ethmoid Bone Forceps
 Pinzas nasales cortantes, Pinzas para etmoides
 Pincas nasales coupantes, Pincas éthmoidales
 Pinze taglienti per il naso, Pinze etmoidali



Weil-Blakesley
 37-255-01-07 -
 37-258-04-07

Maulbreite Jaw width Anchura de la boca Largeur de mors Larghezza della bocca	gerade straight recto droit diritto	1/1	45° aufgewinkelt angled upward acodado arrib angulé vers le haut angolato verso l'alto		90° aufgewinkelt angled upward acodado arrib angulé vers le haut angolato verso l'alto	
			L	12 cm	L	12 cm
Fig. 1 3,0 mm					37-255-01-07	37-256-01-07 / 37-258-01-07
Fig. 2 3,5 mm					37-255-02-07	37-256-02-07 / 37-258-02-07
Fig. 3 4,5 mm					37-255-03-07	37-256-03-07 / 37-258-03-07
Fig. 4 5,5 mm					37-255-04-07	37-256-04-07 / 37-258-04-07
Fig. 5 6,0 mm					37-255-05-07	

Scharfe Nasenzangen, Siebbeinzangen

Nasal Cutting Forceps, Ethmoid Bone Forceps
 Pinzas nasales cortantes, Pinzas para etmoides
 Pincas nasales coupantes, Pincas éthmoidales
 Pinze taglienti per il naso, Pinze etmoidali

Rhinologie

Rhinology
 Rinología
 Rhinologie
 Rinologia

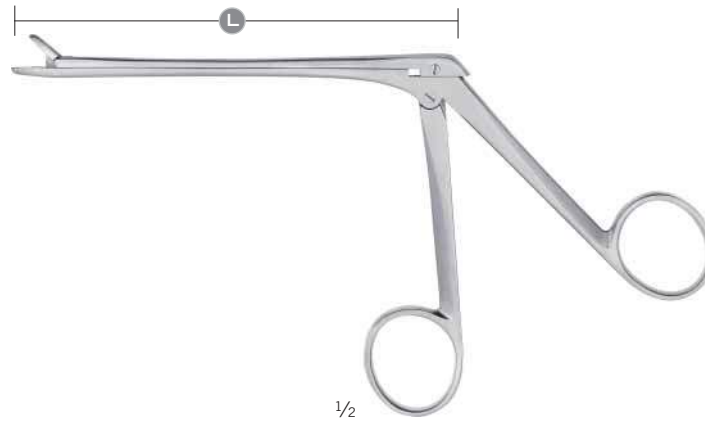
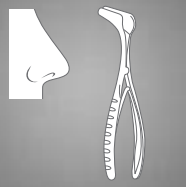

St. Barts
 37-259-12-07 -
 37-261-12-07

37



Maulbreite Jaw width Anchura de la boca Largeur de mors Larghezza della bocca		gerade straight recto droit diritto	30° aufgewinkelt angled upward acodado arrib angulé vers le haut angolato verso l'alto	30° abgewinkelt angled downward acodado abajo angulé vers le bas angolato verso il basso
	1/1			
	L	12 cm	12 cm	12 cm
	3,0 mm		37-259-12-07	37-260-12-07

Scharfe Nasenzangen, Siebbeinzangen

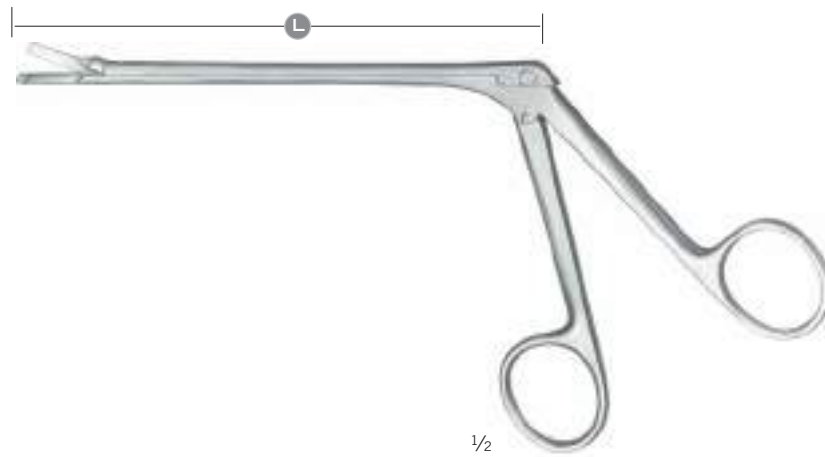
Nasal Cutting Forceps, Ethmoid Bone Forceps
 Pinzas nasales cortantes, Pinzas para etmoides
 Pincas nasales coupantes, Pincas éthmoidales
 Pinze taglienti per il naso, Pinze etmoidali



Struycken
 37-285-01-07

<p>Maulbreite Jaw width Anchura de la boca Largeur de mors Larghezza della bocca</p> <p>Fig. 1 1,0 mm</p> 	<p>gerade straight recto droit diritto</p> <p>$\frac{1}{1}$</p>  <p>L 12 cm</p> <p>37-285-01-07</p>
--	--

Antrumstanzen

Antrum Punches

Pinzas sacabocadas para seno maxilar

Pinces emporte-pièces pour sinus maxillaire

Pinze taglianti per seno mascellare

Rhinologie

Rhinology

Rinología

Rhinologie

Rinologia

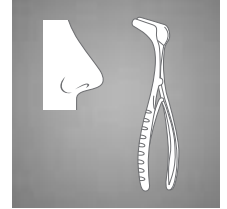

37

37-308-01-07 -
37-308-03-07





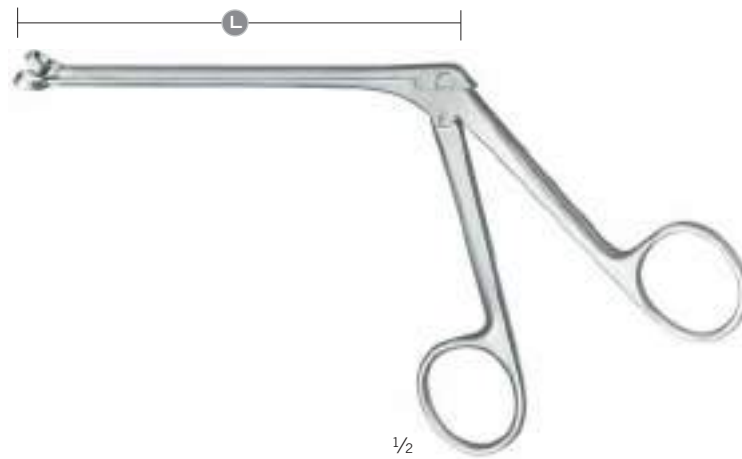

Maulbreite Jaw width Anchura de la boca Largeur de mors Larghezza della bocca	$\frac{1}{1}$	retrograd aufwärts schneidend retrograde, up cutting retrógrado, cortante en la parte superior retrograde, coupant en haut retrogrado, taglio in su	retrograd rechts schneidend retrograde, right cutting retrógrado, cortante a la derecha retrograde, coupant à droit retrogrado, taglio destro	retrograd links schneidend retrograde, left cutting retrógrado, cortante a la izquierda retrograde, coupant à gauche retrogrado, taglio sinistro
	L	10 cm	10 cm	10 cm
2,5 mm		37-308-01-07	37-308-02-07	37-308-03-07

Scharfe Nasenzangen

Nasal Cutting Forceps
 Pinzas nasales cortantes
 Pince nasales coupantes
 Pinze taglienti per il naso



Hartmann Schmieden
 37-309-01-07 - 37-313-12-07
 37-309-04-07

Maulbreite Jaw width Anchura de la boca Largeur de mors Larghezza della bocca	$\frac{1}{1}$		
		Hartmann	Schmieden
	L	12 cm	12 cm
Fig. 1 Ø 5,0 mm		37-309-01-07	
Fig. 2 Ø 7,0 mm		37-309-02-07	
Fig. 3 Ø 9,0 mm		37-309-03-07	
Fig. 4 Ø 11,0 mm		37-309-04-07	
8,0 mm			37-313-12-07

Septumzangen, Septumquetschzange

Septum Forceps, Septum Morselizer

Pinzas para tabique nasal, Pinza para aplastamiento

Pinces pour la cloison nasale, Pince-gouge pour la cloison nasale

Pinze per il setto nasale, Pinza contundente per il setto nasale

Rhinologie

Rhinology

Rinología

Rhinologie

Rinologia

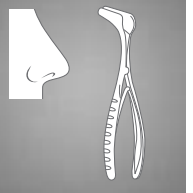

1/1

durchschneidend
through-cutting
cortante
tranchante
tagliante

1/2

Middleton-Jansen
37-323-19-07
20,5 cm / 8 1/8"



1/1

1/2

Middleton-Jansen
37-327-19-07
20 cm / 7 7/8"

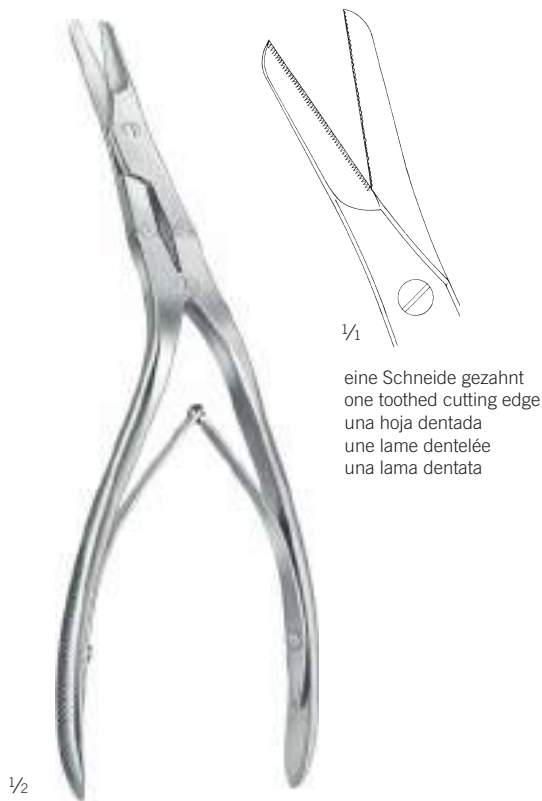

1/1

eine Schneide gezahnt
one toothed cutting edge
una hoja dentada
une lame dentelée
una lama dentata

1/2

Caplan
37-331-20-07
20 cm / 7 7/8"

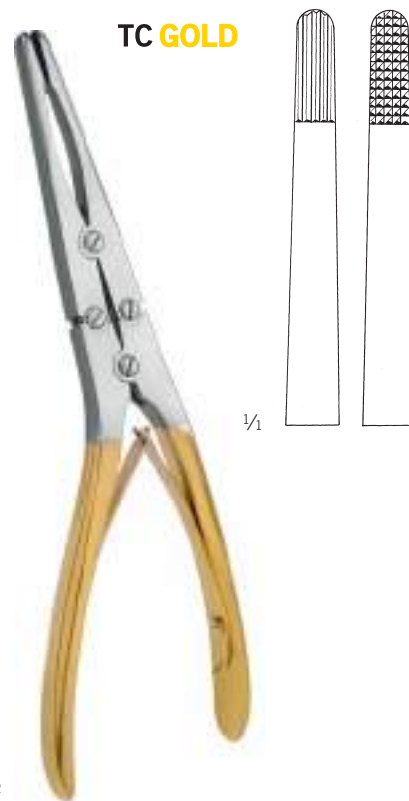

TC GOLD

1/1

1/2

37-334-21-07
20 cm / 7 7/8"

Septumquetschzangen

Septum Morselizers

Pinzas para aplastamiento

Pinces-gouge pour la cloison nasale

Pinze contundente per il setto nasale

TC GOLD



Rubin
37-335-20-07
20 cm / 7 7/8"



Rubin
37-335-21-07
18,5 cm / 7 2/8"



Rubin
37-337-21-07
18,5 cm / 7 2/8"



Rubin
37-335-01-07
Schutzkappe
Protection Cap
Caperuza protectora
Capuchon protecteur
Calotta protettiva

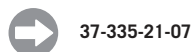

37-335-21-07

Keilbeinstanzen

Sphenoid Bone Punches
 Pinzas sacabocadas para esfenoides
 Pincas emporte-pièces pour sinus sphénoïdal
 Pinze taglienti per seno sfenoidale

Rhinologie
 Rhinology
 Rinología
 Rhinologie
 Rinologia

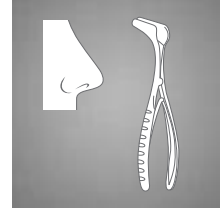

Hajek
 37-340-13-07 -
 37-343-12-07

37

Maulbreite Jaw width Anchura de la boca Largeur de mors Larghezza della bocca		90° aufwärts schneidend cutting upward corte arriba tranchant vers le haut tagliente verso l'alto	90° abwärts schneidend cutting downward desmontable, corte abajo tranchant vers le bas tagliente verso il basso
	¹ / ₁		
	L	14 cm	14 cm
3,5 mm		37-342-12-07	37-343-12-07
4,0 mm		37-340-13-07	37-341-13-07

Keilbeinstanzen

Sphenoid Bone Punches

Pinzas sacabocadas para esfenoides

Pinces emporte-pièces pour sinus sphénoïdal

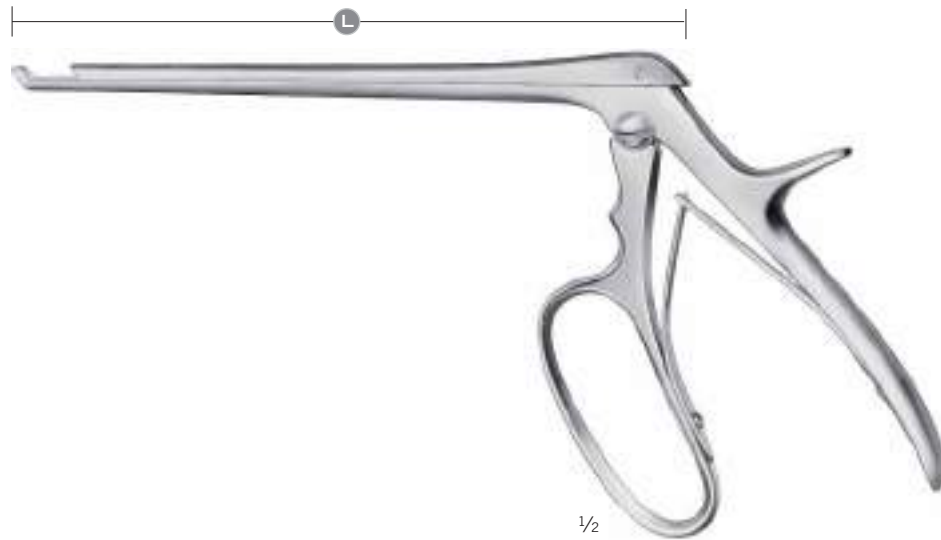

Pinze taglienti per seno sfenoidale



Ferris-Smith-Kerrison

37-356-17-07 -

37-362-05-07

Maulbreite Jaw width Anchura de la boca Largeur de mors Larghezza della bocca		90° aufwärts schneidend cutting upward corte arriba tranchant vers le haut tagliente verso l'alto	90° abwärts schneidend cutting downward desmontable, corte abajo tranchant vers le bas tagliente verso il basso	40° abwärts schneidend cutting downward desmontable, corte abajo tranchant vers le bas tagliente verso il basso
	$\frac{1}{1}$.	.	.
	L	18 cm	18 cm	18 cm
3 mm		37-356-17-07	37-357-17-07	37-362-03-07
5 mm		37-360-17-07	37-361-17-07	37-362-05-07

Keilbeinstanzen

Sphenoid Bone Punches
 Pinzas sacabocadas para esfenoides
 Pincas emporte-pièces pour sinus sphénoïdal
 Pinze taglianti per seno sfenoidale

Rhinologie
 Rhinology
 Rinología
 Rhinologie
 Rinologia

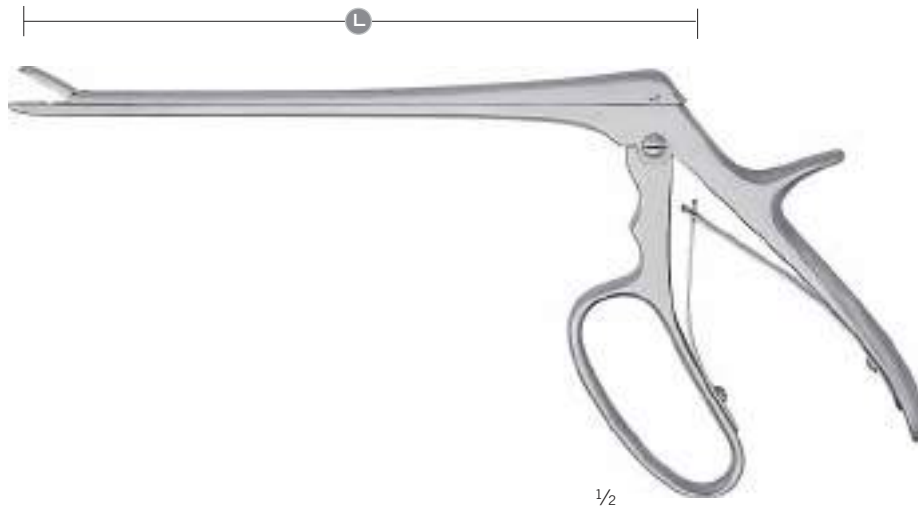
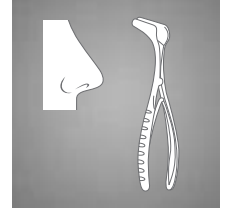

37-364-02-07 -
 37-367-04-07

37

Maulbreite Jaw width Anchura de la boca Largeur de mors Larghezza della bocca		gerade straight recto droit diritto	30° aufgewinkelt angled upward acodado arrib angulé vers le haut angolato verso l'alto	30° abgewinkelt angled downward acodado abajo angulé vers le bas angolato verso il basso
		$\frac{1}{1}$		
	L	18 cm	18 cm	18 cm
10 x 2 mm		37-364-02-07	37-365-02-07	37-367-02-07
10 x 3 mm		37-364-03-07	37-365-03-07	37-367-03-07
10 x 4 mm		37-364-04-07	37-365-04-07	37-367-04-07
10 x 5 mm		37-364-05-07		
10 x 6 mm		37-364-06-07		

Antrumstanzen

Antrum Punches





Pinzas sacabocadas para seno maxilar

Pinces emporte-pièces pour sinus maxillaire

Pinze taglienti per seno mascellare



Kerrison
37-389-00-07 -
37-389-03-07

<p>Maulbreite Jaw width Anchura de la boca Largeur de mors Larghezza della bocca</p>	<p>90° aufwärts schneidend cutting upward corte arriba tranchant vers le haut tagliente verso l'alto</p>
	 <p>$\frac{1}{1}$</p>
	<p>L 9 cm</p>
<p>3 x 3 mm </p>	<p>37-389-00-07</p>
<p>4 x 4 mm </p>	<p>37-389-01-07</p>
<p>5 x 5 mm </p>	<p>37-389-02-07</p>
<p>6 x 6 mm </p>	<p>37-389-03-07</p>

Rhinoplastik-Messer

Rhinoplastic Knives
Cuchillos rinoplásticos
Couteaux pour plastie du nez
Bisturi per plastica nasale

Rhinologie

Rhinology
Rinología
Rhinologie
Rinologia

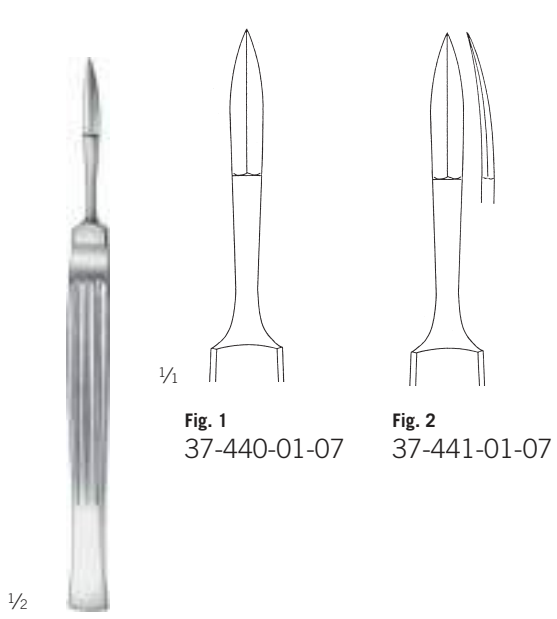
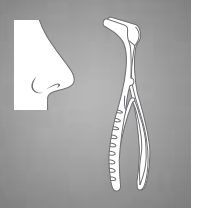
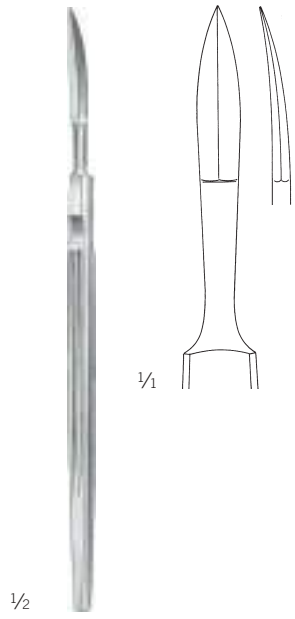
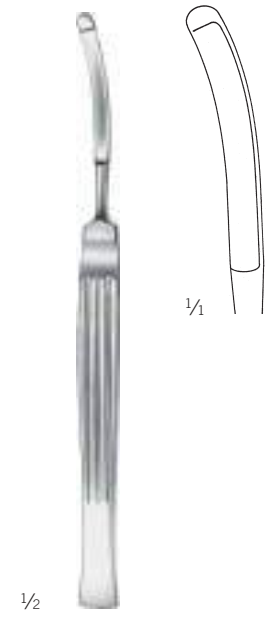

Fig. 1
37-440-01-07

Fig. 2
37-441-01-07



Fomon
37-444-16-07
16,5 cm / 6 4/8"



Converse
37-459-16-07
16 cm / 6 2/8"

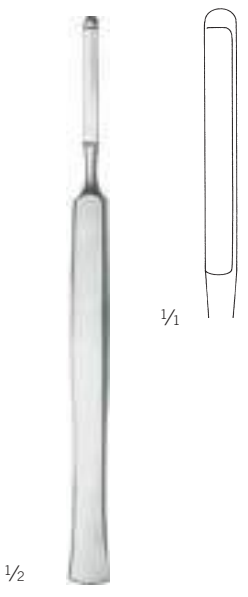

Joseph
37-466-15-07
15,5 cm / 6 1/8"

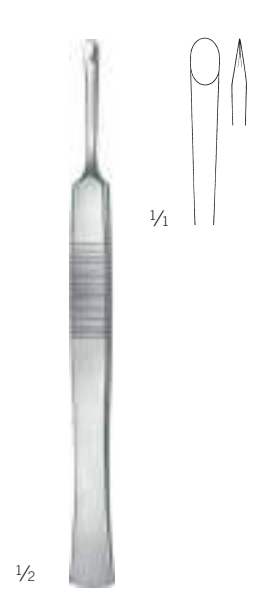

Cottle
37-468-15-07
14 cm / 5 4/8"

37

Septummesser, Schwingmesser

Septum Knives, Swivel Knives
 Cuchillos para tabique nasal
 Bistouris pour la cloison nasale
 Bisturi per il setto nasale



Freer
 37-484-15-07
 16,5 cm / 6 4/8"
 Mukosamesser
 Mucosa Knife
 Cuchillo para mucosa
 Couteau pour muqueuse
 Bisturi per mucosa



Freer
 37-497-19-07
 19 cm / 7 4/8"



Freer
 37-499-19-07
 18,5 cm / 7 2/8"



3 mm 37-504-03-07
 4 mm 37-504-04-07
 5 mm 37-504-05-07

Ballenger
 37-504-03-07 -
 37-504-05-07
 21 cm / 8 2/8"

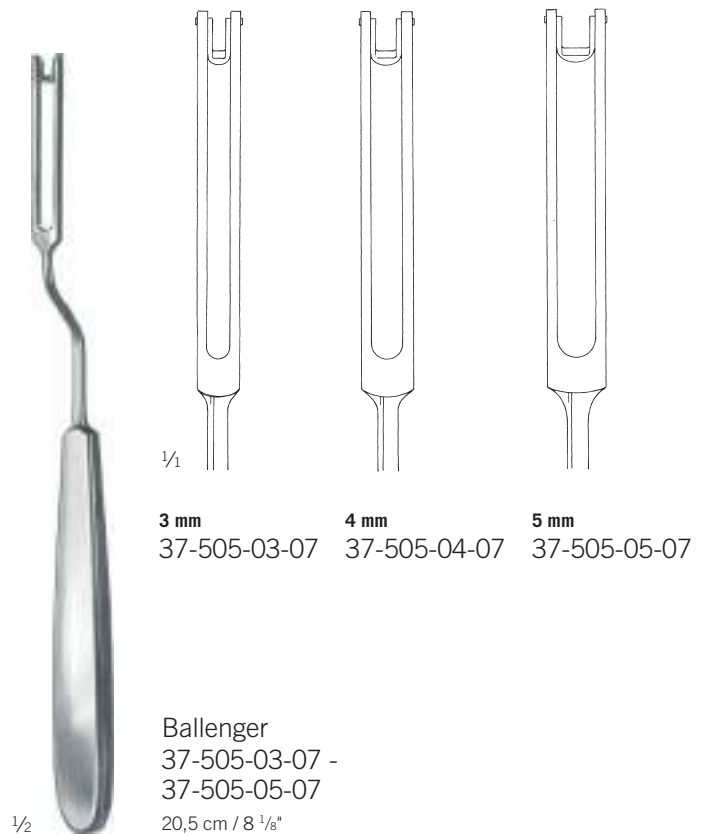

3 mm 37-505-03-07
 4 mm 37-505-04-07
 5 mm 37-505-05-07

Ballenger
 37-505-03-07 -
 37-505-05-07
 20,5 cm / 8 1/8"

Septumelevatorien

Septum Elevators

Elevadores para tabique nasal

Élévateurs pour la cloison nasale

Elevatori per il setto nasale

Rhinologie

Rhinology

Rinología

Rhinologie

Rinologia

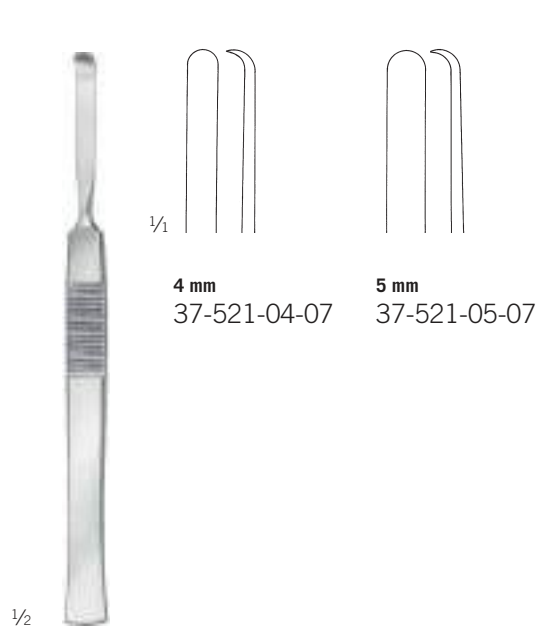
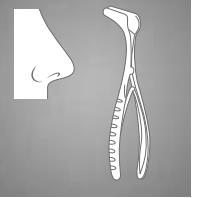

4 mm
37-521-04-07

5 mm
37-521-05-07

McKenty
37-521-04-07 -
37-521-05-07
15 cm / 5 7/8"

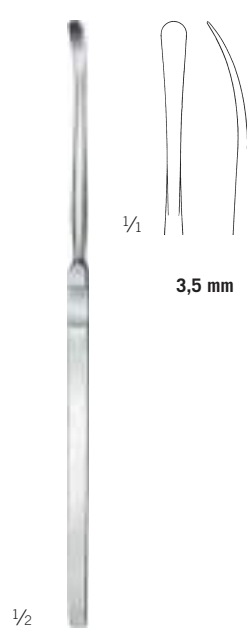

3,5 mm

Halle
37-525-16-07
16 cm / 6 2/8"

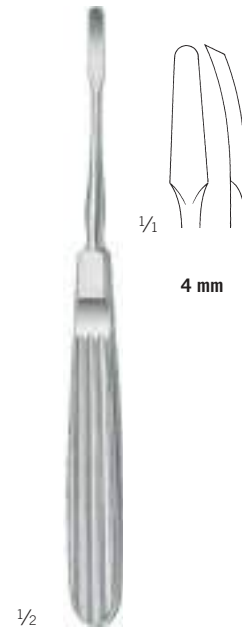

4 mm

Joseph
37-531-16-07
16,5 cm / 6 4/8"

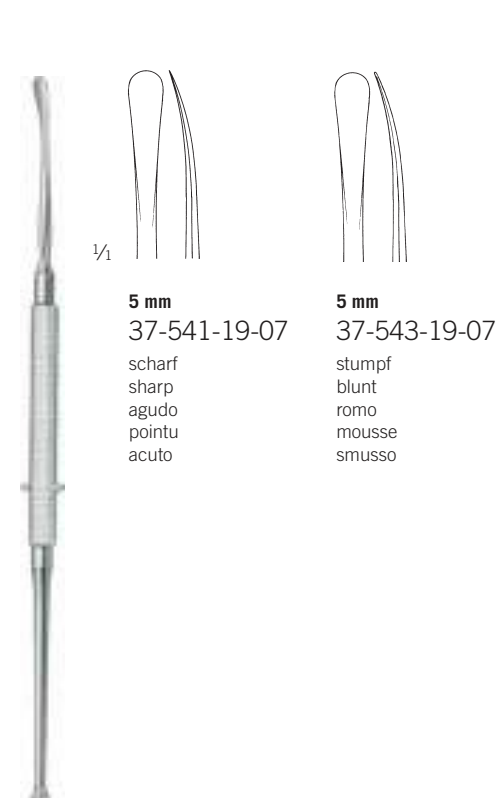

5 mm
37-541-19-07

scharf
sharp
agudo
pointu
acuto

5 mm
37-543-19-07

stumpf
blunt
romo
mousse
smusso

Freer
37-541-19-07 -
37-543-19-07
19 cm / 7 4/8"



37-544-01-07
24,5 cm / 9 5/8"

37-544-02-07
24 cm / 9 4/8"

Krenkel
37-544-01-07 -
37-544-02-07

Gaumenraspatorium
Cleft Palate Periosteal Raspatory
Legra para el paladar
Raspatoir pour palais
Raspatore per palato

Septumelevatorien

Septum Elevators

Elevadores para tabique nasal

Élévateurs pour la cloison nasale

Elevatori per il setto nasale

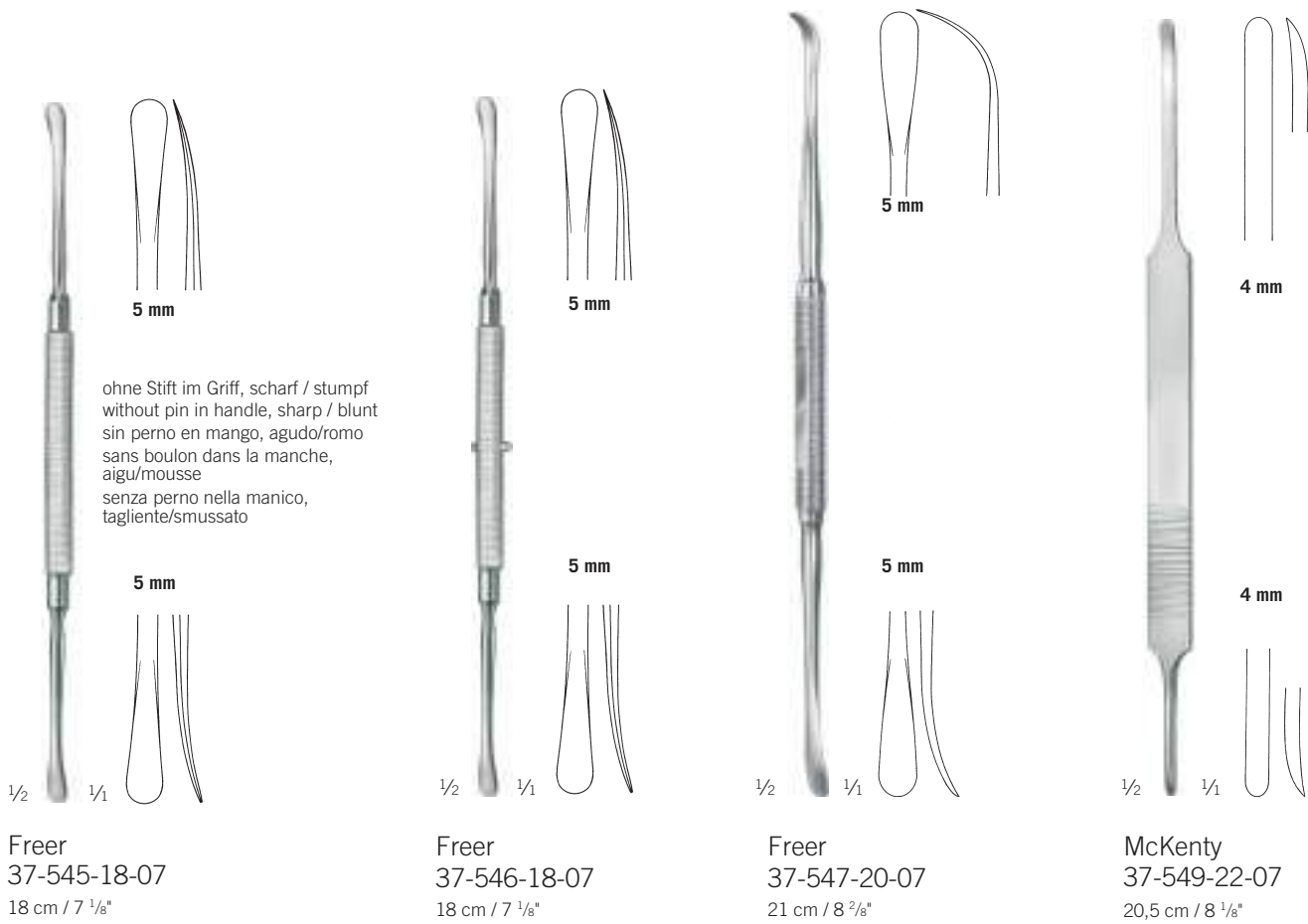

Septumlevatorien

Septum Elevators

Elevadores para tabique nasal

Élévateurs pour la cloison nasale

Elevatori per il setto nasale

Rhinologie

Rhinology

Rinología

Rhinologie

Rinologia

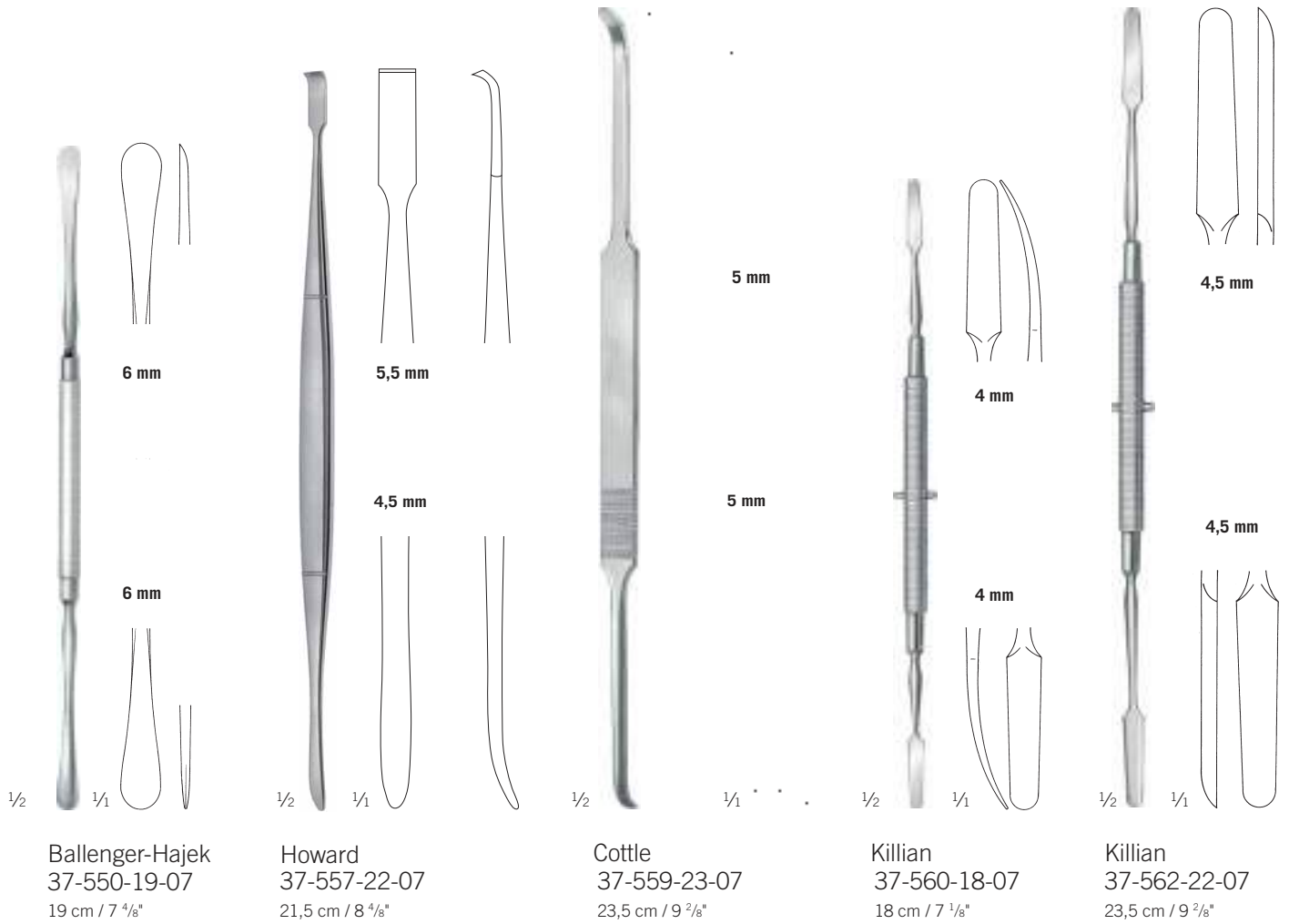
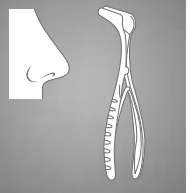

37

Periostelevatorien

Periosteal Elevators
 Legras para periostio
 Elévateurs pour le périoste
 Elevatori per il periostio

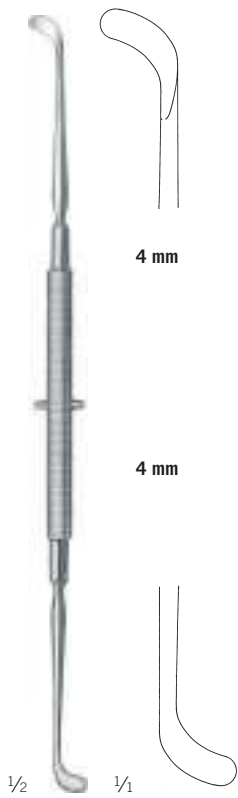

Pennington
 37-568-21-07
 21,5 cm / 8 4/8"



Roger
 37-572-19-07
 20 cm / 7 7/8"



Joseph-Masing
 37-579-22-07
 21,5 cm / 8 4/8"

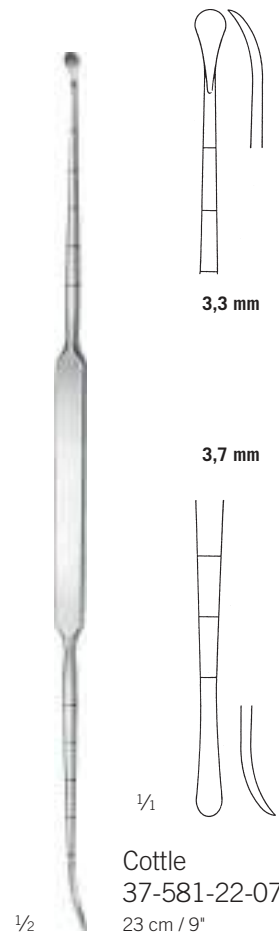

Cottle
 37-581-22-07
 23 cm / 9"

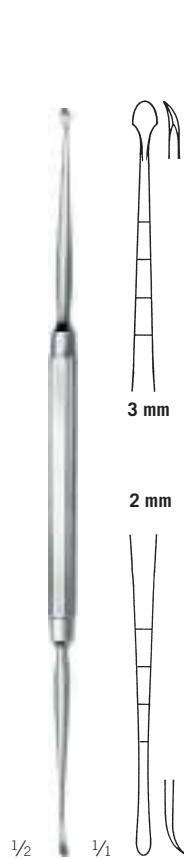

Masing
 37-583-21-07
 19,5 cm / 7 5/8"

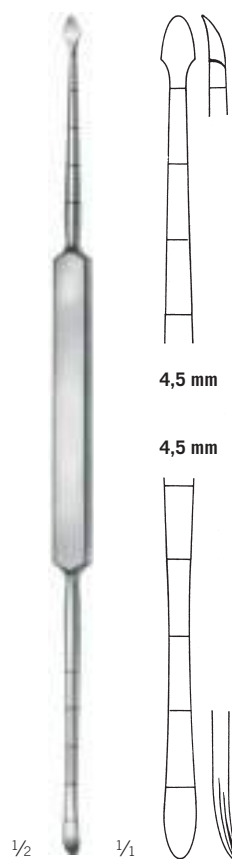

Cottle
 37-584-21-07
 22 cm / 8 5/8"

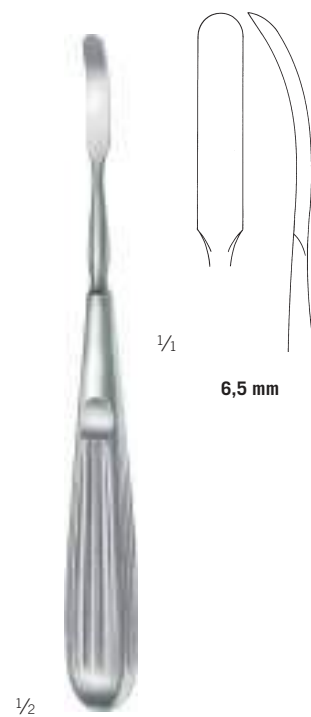

Joseph
 37-585-16-07
 18 cm / 7 1/8"

Septummeißel, Septum-Hohlmeißel

Septum Chisels, Septum Gouges

Cinceles para tabique nasal, Gubias para tabique nasal

Élévateurs pour le périoste, Gouges pour la cloison nasale

Elevatori per il periosto, Sgorbie per il setto nasale

Rhinologie

Rhinology

Rinología

Rhinologie

Rinologia

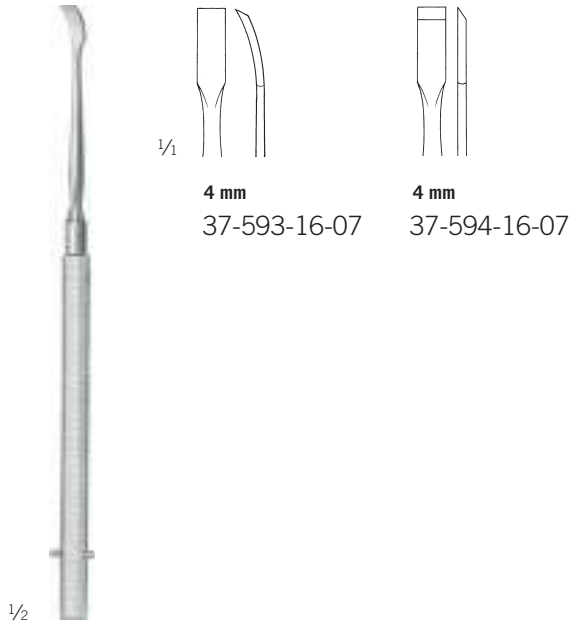
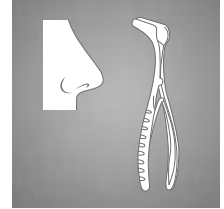

Freer
37-593-16-07 -
37-594-16-07
16,5 cm / 6 5/8"

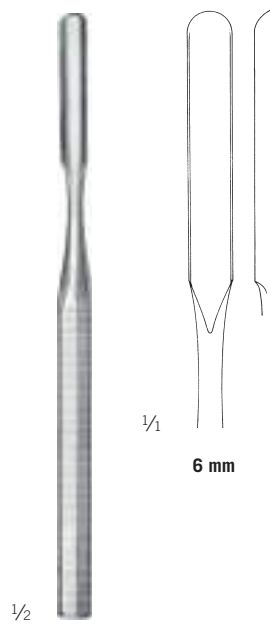

Freer
37-595-15-07
16 cm / 6 2/8"

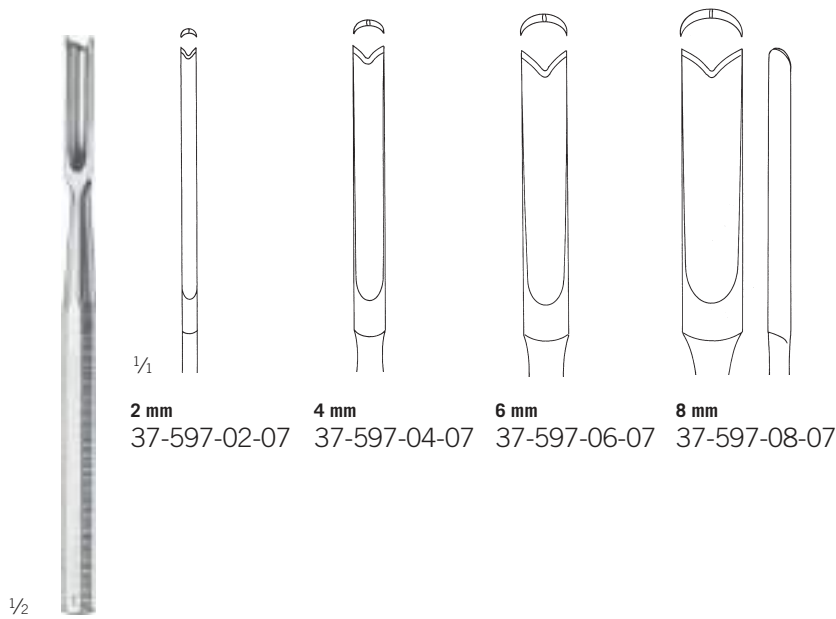

Ballenger
37-597-02-07 -
37-597-08-07
15 cm / 5 7/8"

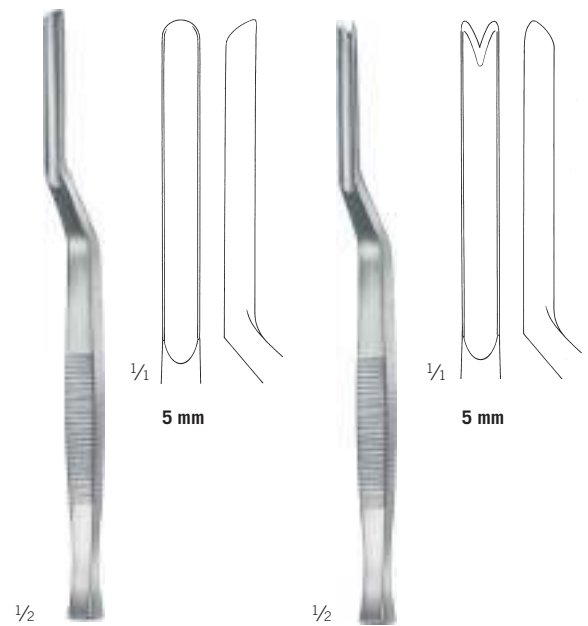

Killian
37-601-16-07
16 cm / 6 2/8"

Killian-Claus
37-605-16-07
16 cm / 6 2/8"

37

Osteotome

Osteotomes
 Osteótomos
 Ostéotomes
 Osteotomi

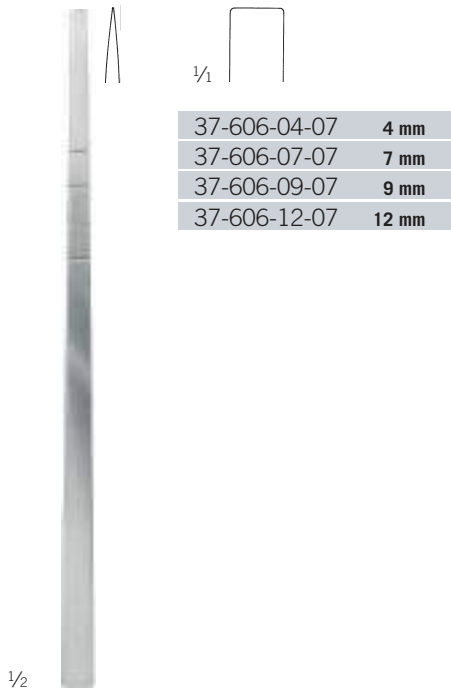

Cottle
 37-606-04-07 -
 37-606-12-07
 18,5 cm / 7 2/8"



Cottle
 37-607-06-07
 18,5 cm / 7 2/8"

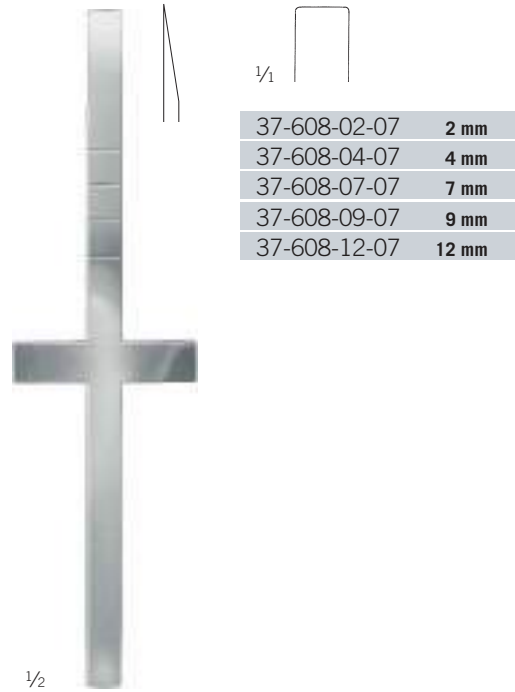

Cottle
 37-608-02-07 -
 37-608-12-07
 18,5 cm / 7 2/8"



Cottle
 37-609-06-07
 18,5 cm / 7 2/8"

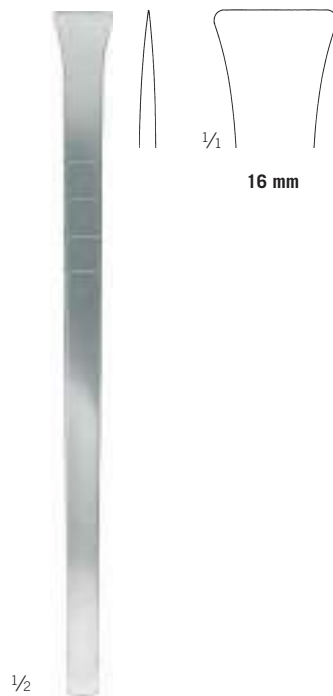

Cottle
 37-610-16-07
 18,5 cm / 7 2/8"



Cottle
 37-612-16-07
 18,5 cm / 7 2/8"

Osteotome, Meißel

Osteotomes, Chisels
 Osteótomos, Cinceles
 Ostéotomes, Ciseaux-burins
 Osteotomi, Scalpelli

Rhinologie

Rhinology
 Rinología
 Rinologie
 Rinologia

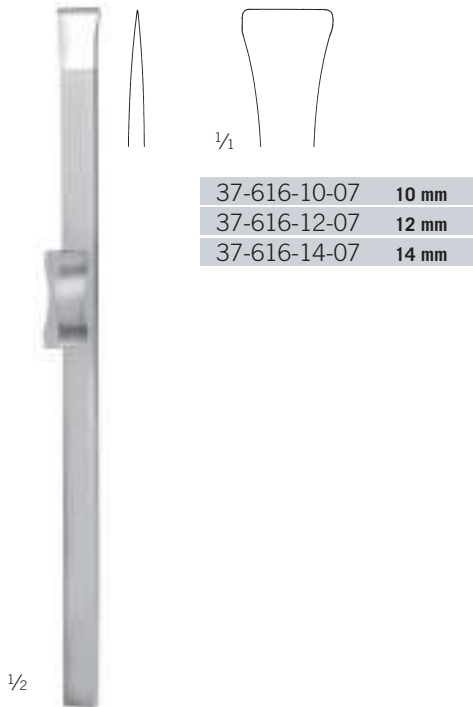
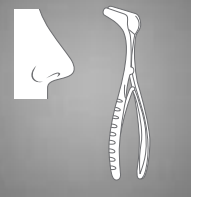

37-616-10-07	10 mm
37-616-12-07	12 mm
37-616-14-07	14 mm

Rubin
 37-616-10-07 -
 37-616-14-07
 18,5 cm / 7 ²/₈"



3 mm	4,5 mm
37-620-03-07	37-620-04-07

Walter
 37-620-03-07 -
 37-620-04-07
 19 cm / 7 ⁴/₈"

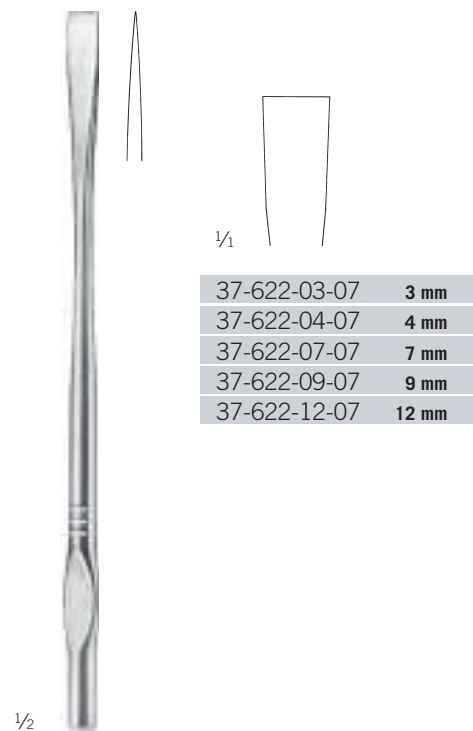

37-622-03-07	3 mm
37-622-04-07	4 mm
37-622-07-07	7 mm
37-622-09-07	9 mm
37-622-12-07	12 mm

Walter
 37-622-03-07 -
 37-622-12-07
 19 cm / 7 ⁴/₈"

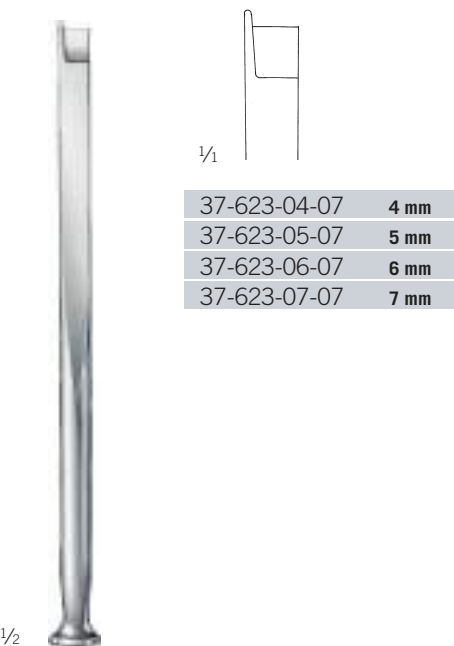

37-623-04-07	4 mm
37-623-05-07	5 mm
37-623-06-07	6 mm
37-623-07-07	7 mm

Fomon
 37-623-04-07 -
 37-623-07-07
 16 cm / 6 ²/₈"

37

Nasenmeißel, Meißel

Rhinoplastic Chisels, Chisels

Cinceles nasales, Cinceles

Ciseaux-burins nasaux, Ciseaux-burins

Scalpelli nasali, Scalpelli

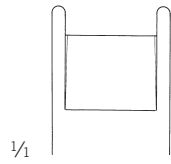

37-624-10-07	10 mm
37-624-12-07	12 mm
37-624-14-07	14 mm
37-624-16-07	16 mm

1/2

Cinelli
37-624-10-07 -
37-624-16-07
16 cm / 6 2/8"

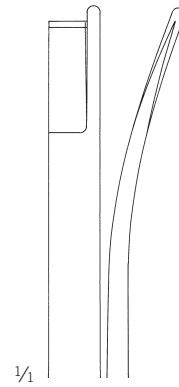

1/1

7 mm
37-625-01-07

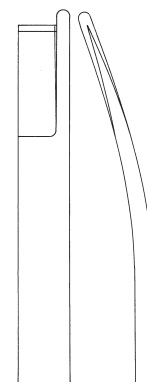

7 mm
37-625-02-07

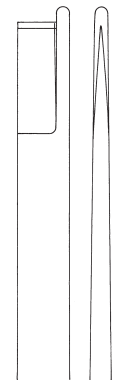

7 mm
37-625-03-07

1/2

Neivert-Anderson
37-625-01-07 -
37-625-03-07
20,5 cm / 8 1/8"

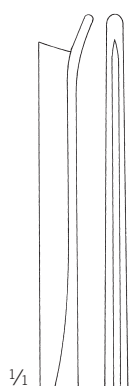

1/1

5 mm

1/2

Silver
37-628-01-07
18 cm / 7 1/8"

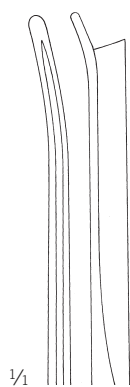

1/1

5 mm

1/2

Silver
37-628-02-07
18 cm / 7 1/8"

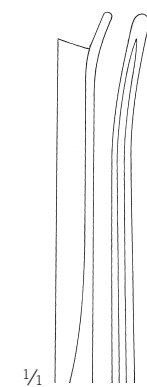

1/1

5 mm

1/2

Silver
37-628-03-07
18 cm / 7 1/8"

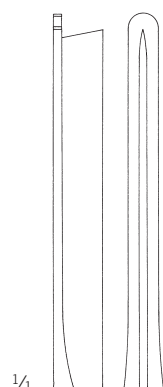

1/1

1/2

Parkes
37-629-01-07
16 cm / 6 2/8"

Nasensägen

Nasal Saws
Sierras nasales
Scies nasales
Seghe nasali

Rhinologie

Rhinology
Rinología
Rhinologie
Rinologia

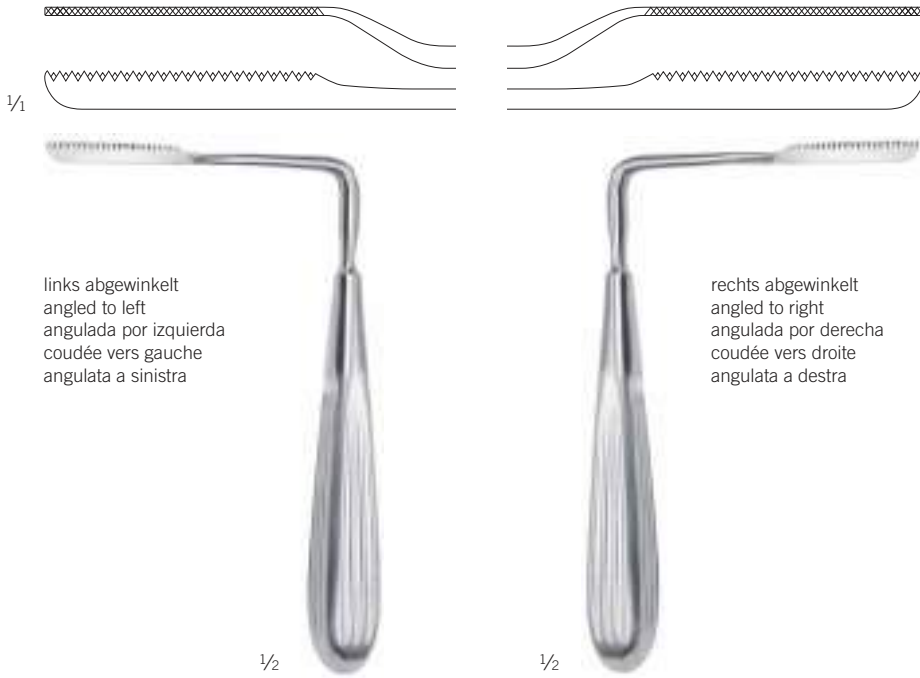
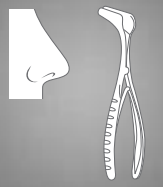

links abgewinkelt
angled to left
angulada por izquierda
coudée vers gauche
angulata a sinistra

rechts abgewinkelt
angled to right
angulada por derecha
coudée vers droite
angulata a destra

Joseph
37-632-20-07
17 cm / 6 5/8"

Joseph
37-634-20-07
17 cm / 6 5/8"

37

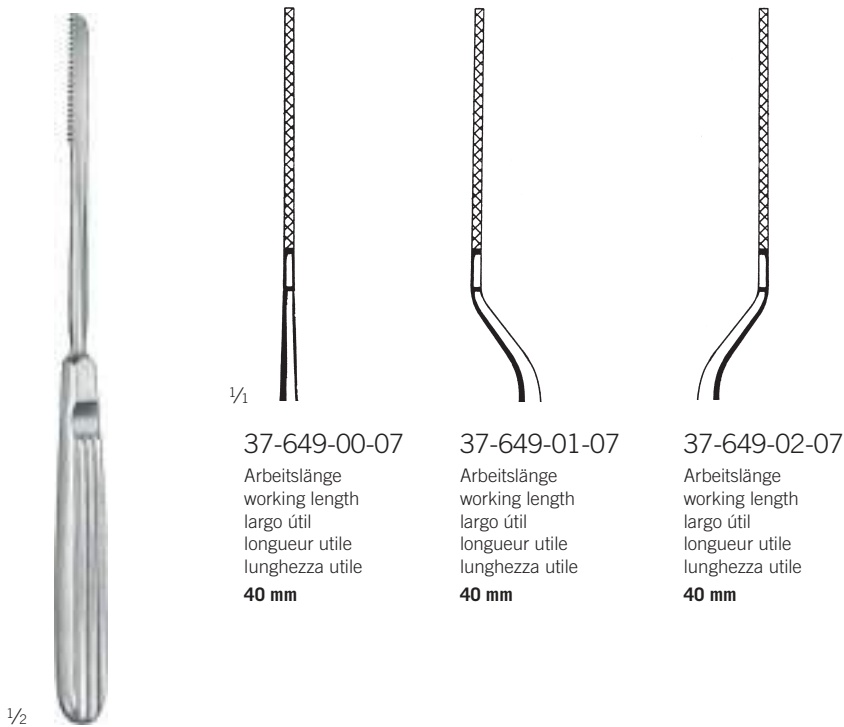

37-649-00-07
Arbeitslänge
working length
largo útil
longueur utile
lunghezza utile
40 mm

37-649-01-07
Arbeitslänge
working length
largo útil
longueur utile
lunghezza utile
40 mm

37-649-02-07
Arbeitslänge
working length
largo útil
longueur utile
lunghezza utile
40 mm

Joseph
37-649-00-07 -
37-649-02-07
19 cm / 7 4/8"

Knorpelquetsche

Cartilage Crusher

Machacadora

Pinces-gouge à cartilage

Torchio per cartilagine

1/2



Cottle
37-650-01-07

12 cm / 4 5/8"

Griff
Handle
Mango
Manche
Manico



37-650-02

1/2



Cottle
37-650-02-07

Führungshilfe für Osteotome
Guide Support for osteotomes
Soporte de guía para osteótomos
Support conducteur pour ostéotomes
Supporto di guida per osteotomi

7 mm breit
7 mm wide
7 mm de ancho
largeur 7 mm
larghezza 7 mm

1/2



Cottle
37-652-00-07

Knorpelquetsche
Cartilage Crusher
Machacadora
Pinces-gouge à cartilage
Torchio per cartilagine

65 x 30 x 30 mm

Nasenraspeln, Knochenfeilen, Antrumraspeln

Nasal Rasps, Bone Files, Antrum Rasps

Escofinas nasales, Limas para huesos, Escofinas para el antro

Râpes nasales, Limes à os, Râpes pour antre

Raspe nasali, Lime per ossa, Raspe per seno mascellare

Rhinologie

Rhinology

Rinología

Rhinologie

Rinologia

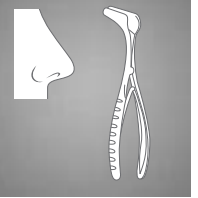

1/2

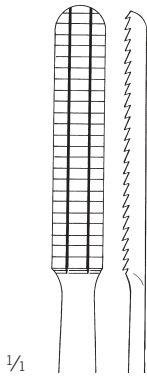

1/1

37-656-01-07

auf Zug schneidend
drawing cut
cortante a tracción
tranchante à traction
tagliente a trazione

34 x 7 mm

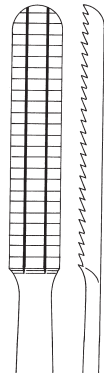

37-656-02-07

auf Stoss schneidend
pushing cut
cortante a empuje
tranchante à impact
tagliente a urto

34 x 7 mm



1/2

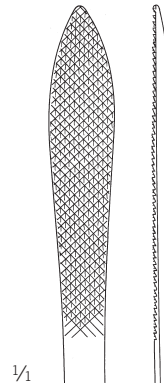

1/1

60 x 8 mm

Maltz
37-656-01-07 -
37-656-02-07
17 cm / 6 5/8"

Joseph
37-658-01-07
16 cm / 6 2/8"

37



1/2

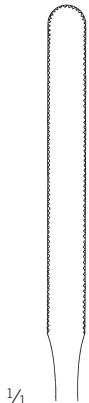

1/1

45 x 6 mm
37-669-01-07



45 x 6 mm
37-669-02-07



45 x 6 mm
37-669-03-07

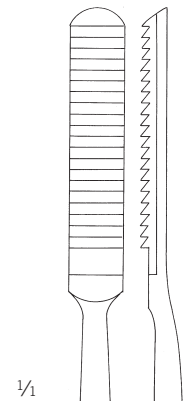

1/1

auf Zug schneidend
drawing cut
cortante a tracción
tranchante à traction
tagliente a trazione

34 x 8 mm



1/2

Gallaher
37-669-01-07 -
37-669-03-07
17 cm / 6 5/8"

Cottle
37-670-21-07
21 cm / 8 2/8"

Glabellaraspeln, Nasenraspeln

Glabella Rasps, Nasal Rasps

Escofinas para glabella, Escofinas nasales

Râpes pour la glabelle, Râpes nasales

Raspe per glabella, Raspe nasali



1/1

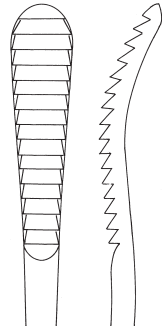
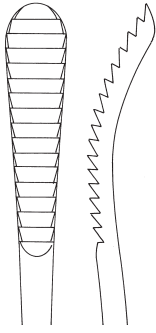

37-671-21-07

auf Stoss schneidend
pushing cut
cortante a empuje
tranchante à impact
tagliente a urto

32 x 9 mm

37-673-21-07

auf Zug schneidend
drawing cut
cortante a tracción
tranchante à traction
tagliente a trazione

32 x 9 mm



1/1

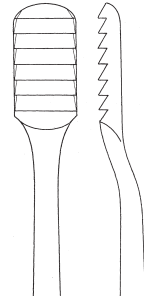
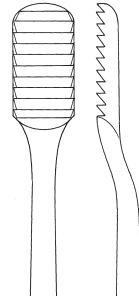

37-674-18-07

auf Stoss schneidend
pushing cut
cortante a empuje
tranchante à impact
tagliente a urto

15 x 8 mm

37-676-18-07

auf Zug schneidend
drawing cut
cortante a tracción
tranchante à traction
tagliente a trazione

15 x 8 mm

1/2

Aufricht

37-671-21-07 -
37-673-21-07

21 cm / 8 2/8"

1/2

Lewis

37-674-18-07 -
37-676-18-07

19 cm / 7 4/8"



1/2

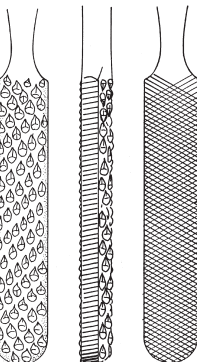
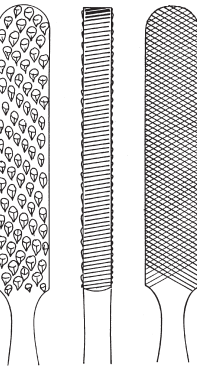

1/1

Fomon

37-680-21-07

20,5 cm / 8 1/8"

Nasenraspeln

Nasal Rasps
Escofinas nasales
Râpes nasales
Raspe nasali

Rhinologie

Rhinology
Rinología
Rhinologie
Rinologia

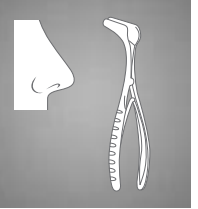

TC GOLD



Fig. 1
37-680-01-07



Fig. 2
37-680-02-07



Fig. 3
37-680-03-07



Fig. 4
37-680-04-07



Fig. 5
37-680-05-07

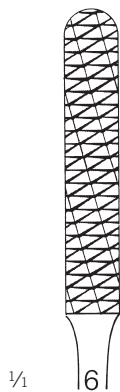

Fig. 6
37-680-06-07



Fig. 7
37-680-07-07



Fig. 8
37-680-08-07



Fig. 9
37-680-09-07



Fig. 10
37-680-10-07



1/2

Maltz
37-680-01-07 -
37-680-10-07
21 cm / 8 2/8"

37

Nasenraspeln

Nasal Rasps
 Escofinas nasales
 Râpes nasales
 Raspe nasali

TC GOLD

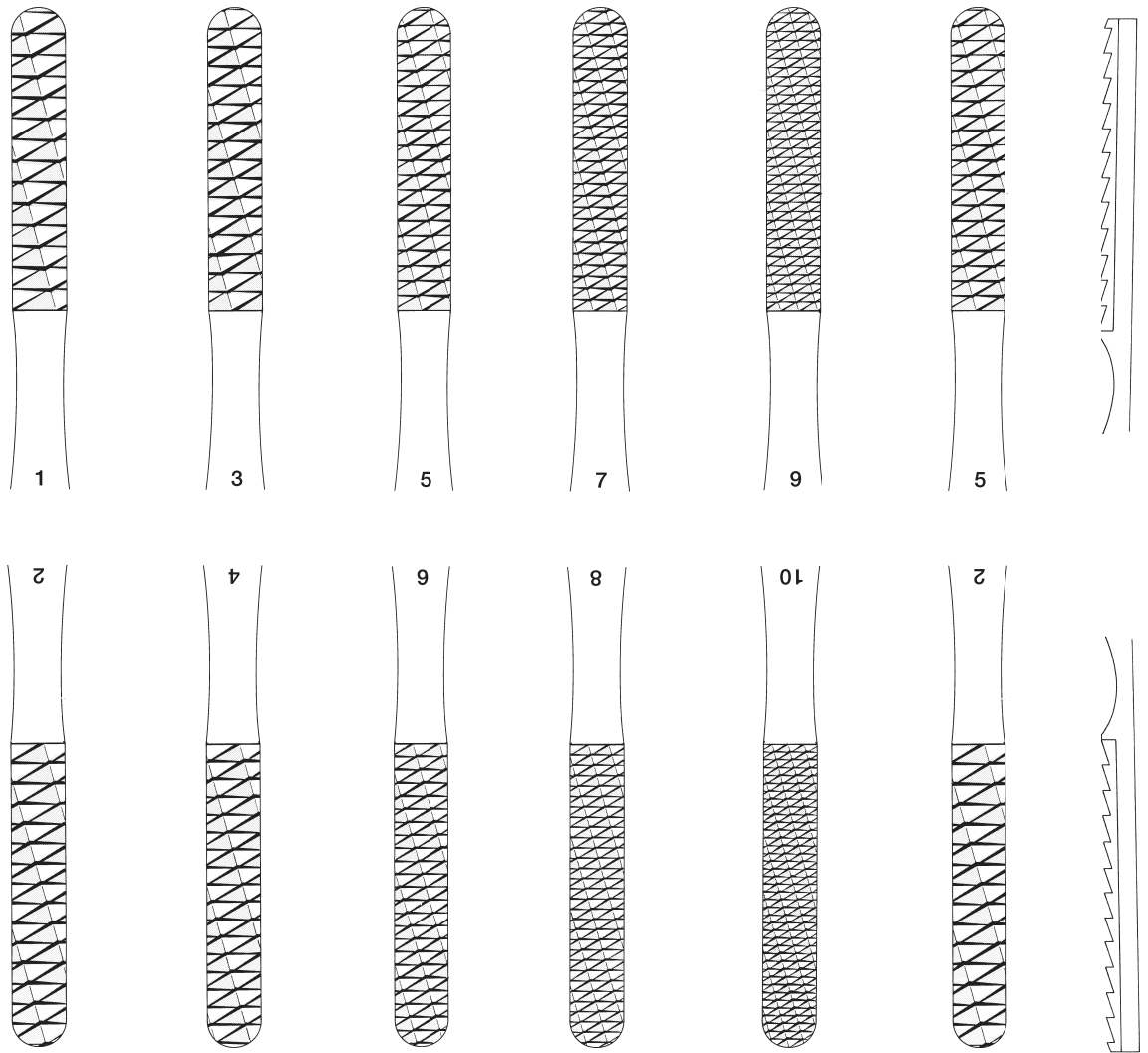

Fig. 1/2
 37-682-01-07
 30 x 8 mm

Fig. 3/4
 37-682-02-07
 40 x 7 mm

Fig. 5/6
 37-682-03-07
 40 x 7 mm

Fig. 7/8
 37-682-04-07
 40 x 7 mm

Fig. 9/10
 37-682-05-07
 40 x 7 mm

Fig. 2/5
 37-682-06-07
 40 x 7 mm

1/2

Fomon
 37-682-01-07 -
 37-682-06-07
 20,5 cm / 8 1/8"

Nasenhäkchen

Nasal Hooklets
Ganchitos nasales
Crochets nasaux
Uncini nasali

Rhinologie

Rhinology
Rinología
Rhinologie
Rinologia

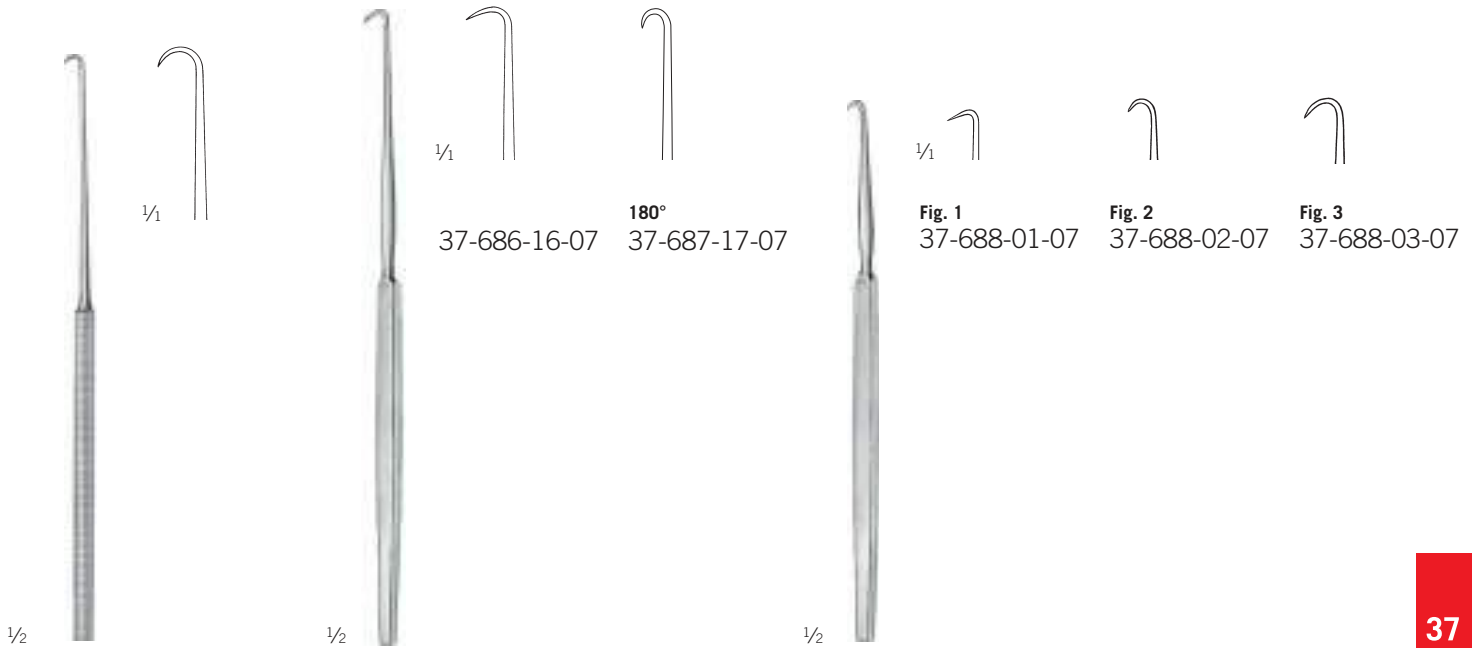
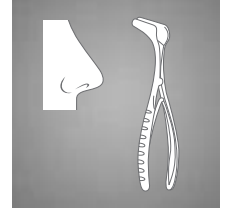

Joseph
37-684-15-07

15,5 cm / 6 1/8"

Schleimhauthäkchen, scharf
Mucosa Hooklet, sharp
Ganchito para mucosa, agudo
Crochet pour la muqueuse, pointu
Uncino per mucosa, acuto

Cottle
37-686-16-07 - 37-687-17-07

17 cm / 6 1/8"

scharf
sharp
agudo
pointu
acuto

Cottle
37-688-01-07 - 37-688-03-07

14,5 cm / 5 9/16"

scharf
sharp
agudo
pointu
acuto

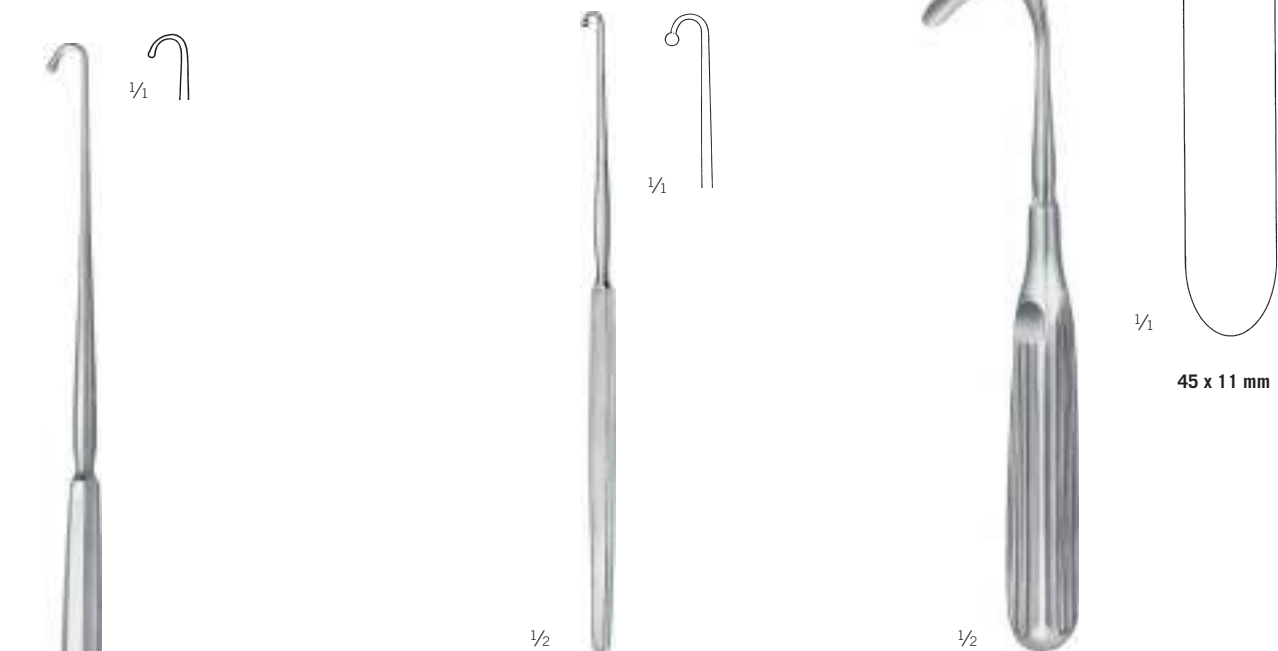

Lange
37-692-22-07

23 cm / 9"

Nasenflügelhäkchen, Knopfende
Alar Hooklet, button end
Ganchito para alas de nariz, botonado
Crochet pour les ailes du nez, boutonné
Uncino per le pinne nasali, con fine a bottone

Fomon
37-694-17-07

17 cm / 6 5/8"

Nasenflügelhäkchen, Knopfende
Alar Hooklet, button end
Ganchito para alas de nariz, botonado
Crochet pour les ailes du nez, boutonné
Uncino per le pinne nasali, con fine a bottone

Aufricht
37-697-19-07

19 cm / 7 4/8"

Nasenhaken
Nasal Retractors
Separadores nasales
Ecarteurs nasaux
Divaricatori nasali

45 x 11 mm

Nasenflügelhäkchen, Schleimhauthäkchen

Alar Hooklets, Mucosa Hooklet

Ganchitos para alas de nariz, Ganchito para mucosa

Crochets pour les ailes du nez, Crochet pour la muqueuse

Uncini per le pinne nasali, Uncino per mucosa



1/2

Kilner
37-698-10-07
8 cm / 3 1/8"
scharf
sharp
agudo
pointu
acuto

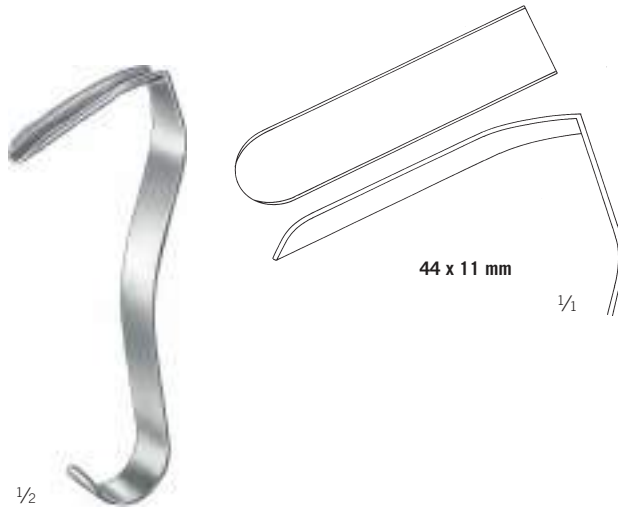

1/2

Converse
37-699-11-07
10,5 cm / 4 1/8"
Nasenhaken
Nasal Retractors
Separadores nasales
Ecarteurs nasaux
Divaricatori nasali



1/2

Converse
37-700-12-07
11,5 cm / 4 5/8"
scharf
sharp
agudo
pointu
acuto



1/2

Freer
37-702-15-07
15 cm / 5 7/8"
scharf
sharp
agudo
pointu
acuto

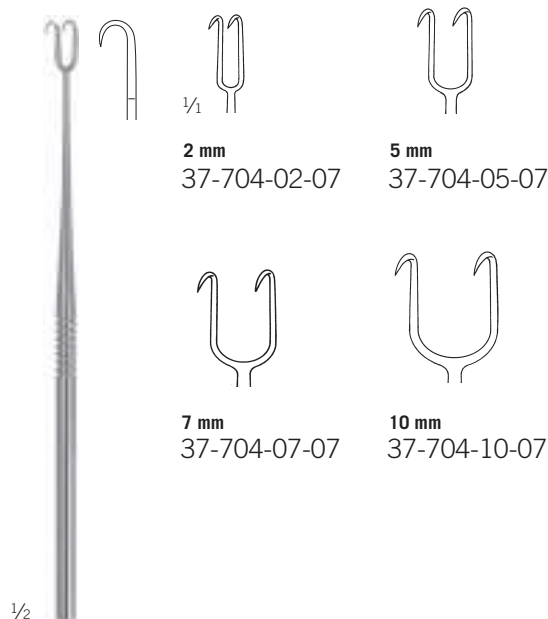

1/2

Joseph
37-704-02-07 -
37-704-10-07
16 cm / 6 1/8"

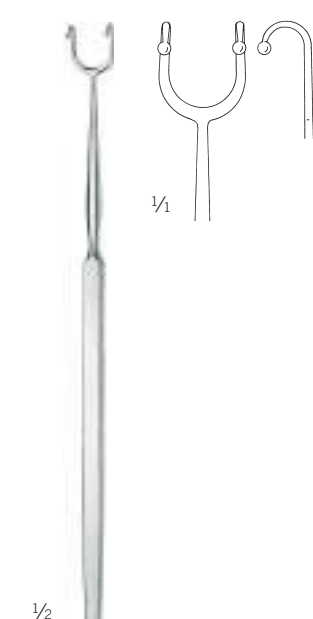

1/2

Fomon
37-706-16-07
16 cm / 6 2/8"
geknöpft
button ended
abotonado
boutonné
a bottone

Nasenflügelhäkchen, Nasenhaken

Alar Hooklets, Nasal Retractors

Ganchitos para alas de nariz, Separadores nasales

Crochets pour les ailes du nez, Ecarteurs nasaux

Uncini per le pinne nasali, Divaricatori nasali

Rhinologie

Rhinology

Rinologia

Rhinologie

Rinologia

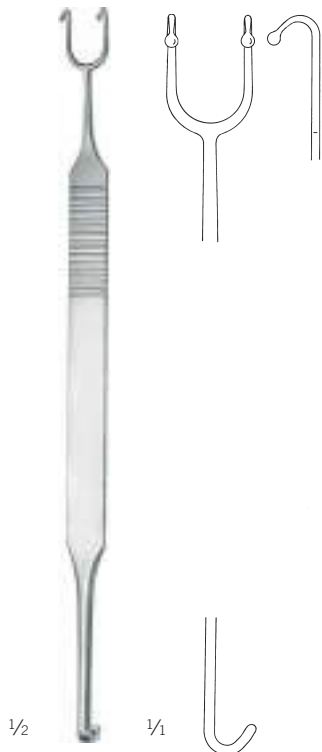
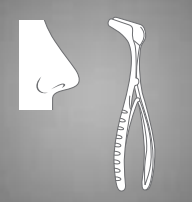

Cottle-Neivert
37-707-20-07
19,5 cm / 7 5/8"



Cottle
37-708-14-07 -
37-709-02-07
14,5 cm / 5 6/8"



37-708-14-07
scharf
sharp
agudo
pointu
acuto

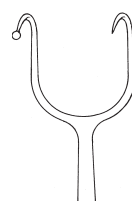

37-709-01-07
stumpf/scharf
blunt/sharp
romo/agudo
mousse/aiguë
smusso/acuto

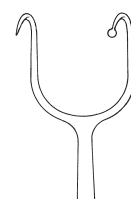

37-709-02-07
scharf/stumpf
sharp/blunt
agudo/romo
aiguë/mousse
acuto/smusse



Cottle
37-710-14-07
14 cm / 5 4/8"

37

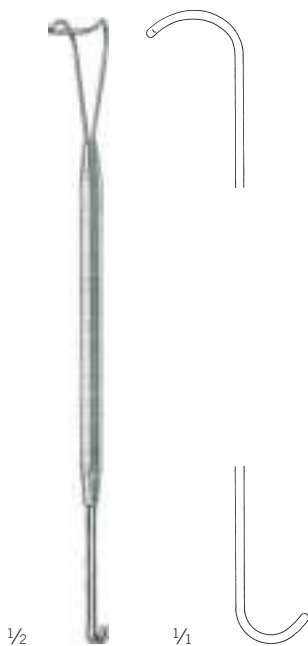

Neivert
37-712-16-07
17 cm / 6 5/8"



Cottle
37-713-15-07
14 cm / 5 4/8"
Sattelhäkchen
Saddle Hook
Separador en forma de silla
Élévateur sous forme de selle
Elevatori in forma di sella



Cottle
37-714-15-07
16 cm / 6 2/8"



Blätter
blades
hojas
lames
lame
60 x 6,5 mm

Aufricht
37-715-14-07
12 cm / 4 5/8"

stumpf
blunt
romo
mousse
smusso

Septumzangen, Septumrichtzangen

Septum Forceps, Septum Straightening Forceps

Pinzas para tabique nasal, Pinzas para enderezar el tabique nasal

Pinces pour la cloison nasale, Pincers pour le redressement de la cloison nasale

Pinze per il setto nasale, Pinze per raddizzare il setto nasale



37-724-01-07

gerade
straight
recta
droite
diritta

37-724-02-07

links
left
izquierdo
gauche
sinistra

37-724-03-07

rechts
right
derecho
droit
destra



1/2

Kressner
37-721-20-07
22 cm / 8 5/8"



1/2

Cottle-Walsham
37-724-01-07 -
37-724-03-07
23 cm / 9"



1/2

Asch
37-725-23-07
22,5 cm / 8 7/8"

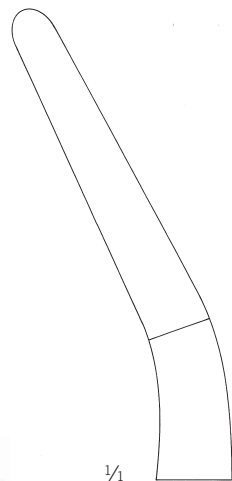

1/1

Hautfasspinzetten, Antrumküretten

Skin Grasping Forceps, Antrum Curettes
 Pinzas para piel, Curetas para el antro
 Pincés pour saisir la peau, Curettes pour l'antre
 Pinze per afferrare la pelle, Curette per antro

Rhinologie

Rhinology
 Rinología
 Rinologie
 Rinologia

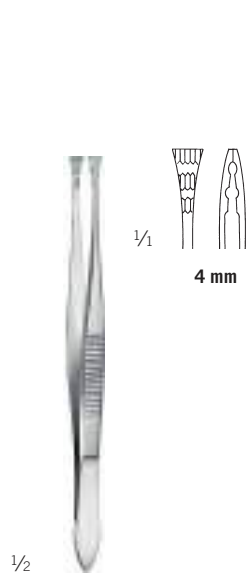
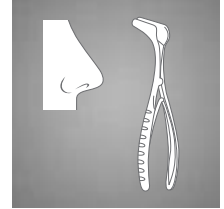

Ogura
 37-728-11-07
 11 cm / 4 3/8"



Cottle
 37-731-14-07
 14 cm / 5 4/8"
 mit Zähnchen
 with teeth
 con dientes
 avec dents
 con denti

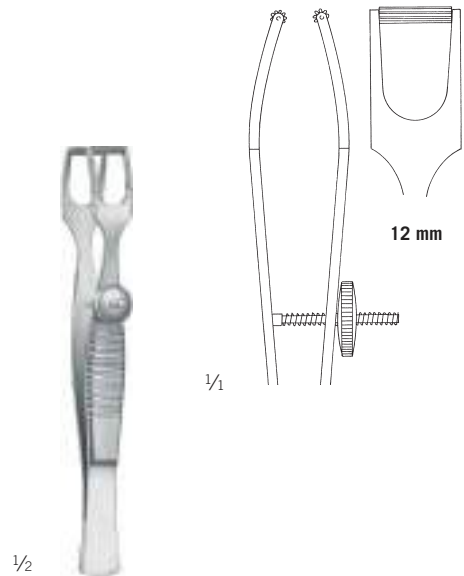

Cottle
 37-732-10-07
 11 cm / 4 3/8"
 Columellapinzette
 Columella Forceps
 Pinza para columela
 Pince à columella
 Pinza per columella



Faulkner
 37-742-21-07
 21 cm / 8 2/8"



Coakley
 37-748-01-07 -
 37-748-06-07
 17 cm / 6 6/8"



Fig. 1
 37-748-01-07



Fig. 2
 37-748-02-07



Fig. 3
 37-748-03-07



Fig. 4
 37-748-04-07



Fig. 5
 37-748-05-07



Fig. 6
 37-748-06-07

Ringmesser, Saugraspatorium, Sinus-Dilatatoren

Adenoid Curettes, Suction Raspatory, Frontal Sinus Dilators

Cuchillos para adenoides, Legra de succión, Dilatadores para el seno

Couteaux à végétations adénoïdales, Rugine-raspatoire à succion, Dilatateurs pour le sinus frontal

Coltelli per vegetazioni adenoidee, Raspatorio con aspiratore, Dilatatori per il seno frontale

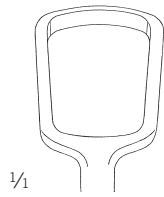
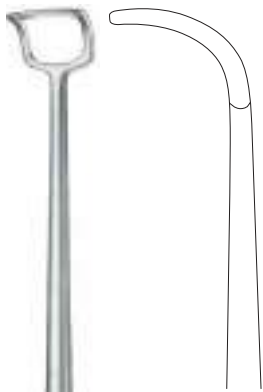

1/1

Fig. 1	37-755-01-07	13 mm
Fig. 2	37-755-02-07	15 mm
Fig. 3	37-755-03-07	17 mm
Fig. 4	37-755-04-07	19 mm
Fig. 5	37-755-05-07	21 mm
Fig. 6	37-755-06-07	23 mm

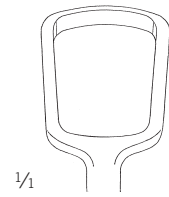

1/1

Fig. 1	37-756-01-07	13 mm
Fig. 2	37-756-02-07	15 mm
Fig. 3	37-756-03-07	17 mm
Fig. 4	37-756-04-07	19 mm
Fig. 5	37-756-05-07	21 mm
Fig. 6	37-756-06-07	23 mm

1/2

Beckmann
37-755-01-07 -
37-755-06-07
22 cm / 8 5/8"

1/2

Beckmann
37-756-01-07 -
37-756-06-07
21,5 cm / 8 1/2"

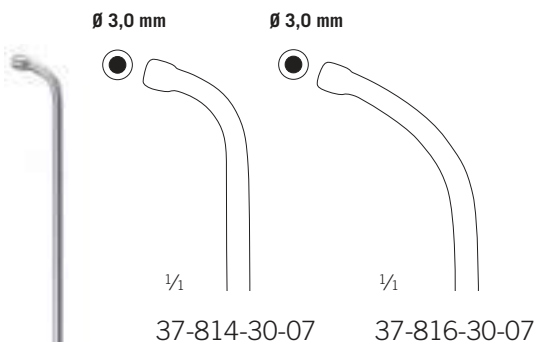

∅ 3,0 mm

∅ 3,0 mm

1/1

1/1

37-814-30-07

37-816-30-07

1/2

Eicken-Killian
37-814-30-07 -
37-816-30-07 -
14 cm / 5 1/2"

Spülkanüle, mit Luer-Lock
Irrigation Cannula, with Luer-Lock
Sonda irrigadora para seno maxilar, con Luer-Lock
Canule à irrigation, avec Luer-Lock
Cannula per lavaggio, con Luer-Lock

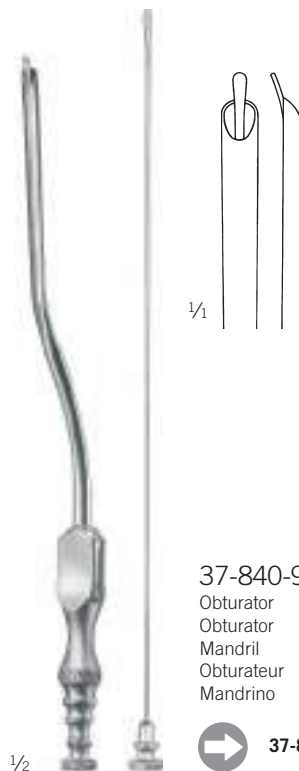

1/1

37-840-90-98
Obturator
Obturator
Mandrill
Obturateur
Mandrino



37-840-20-07

1/2

Guilen
37-840-20-01
19 cm / 7 1/2"



∅ 3,0 mm

37-842-30-07

∅ 4,0 mm

37-842-40-07

1/2

Ritter-Halle
37-842-30-07 -
37-842-40-07
14,5 cm / 5 5/8"

Mund-, Kiefer- und Gesichtschirurgie
Oral Maxillo-facial Surgery
Cirugía oral y maxilofacial
Chirurgie buccale et maxillo-faciale
Chirurgia maxillo-facciale

38,48,50

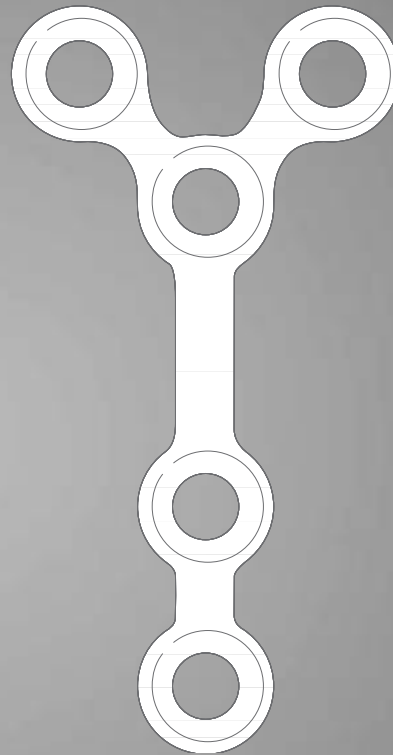
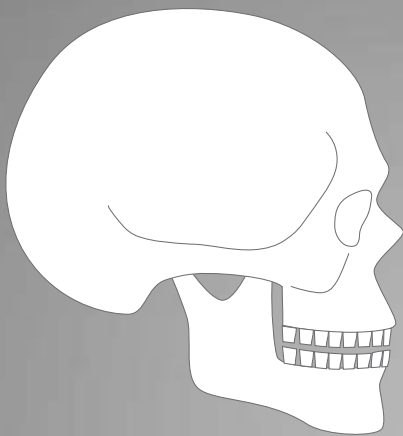

Unser Ordner-System „Craniomaxillofacial Surgery“ enthält die gesamte Palette der KLS-Martin-Implantate und -Instrumente für die Mund-, Kiefer- und Gesichtschirurgie.

Our folder system “Craniomaxillofacial Surgery” contains the full range of KLS-Martin implants and instruments for cranio-maxillofacial surgery.

Nuestro sistema de carpetas “Craniomaxillofacial Surgery” incluye la gama completa de implantes e instrumentos de KLS-Martin para la cirugía oral y maxilofacial.

Notre système de dossiers « Craniomaxillofacial Surgery » contient l'ensemble de la palette des implants et instruments KLS Martin pour la chirurgie buccale et maxillofaciale.

Il nostro sistema di cartelle “Craniomaxillofacial Surgery” contiene la gamma completa degli impianti e degli strumenti di KLS Martin per la chirurgia orale-maxillo-facciale.

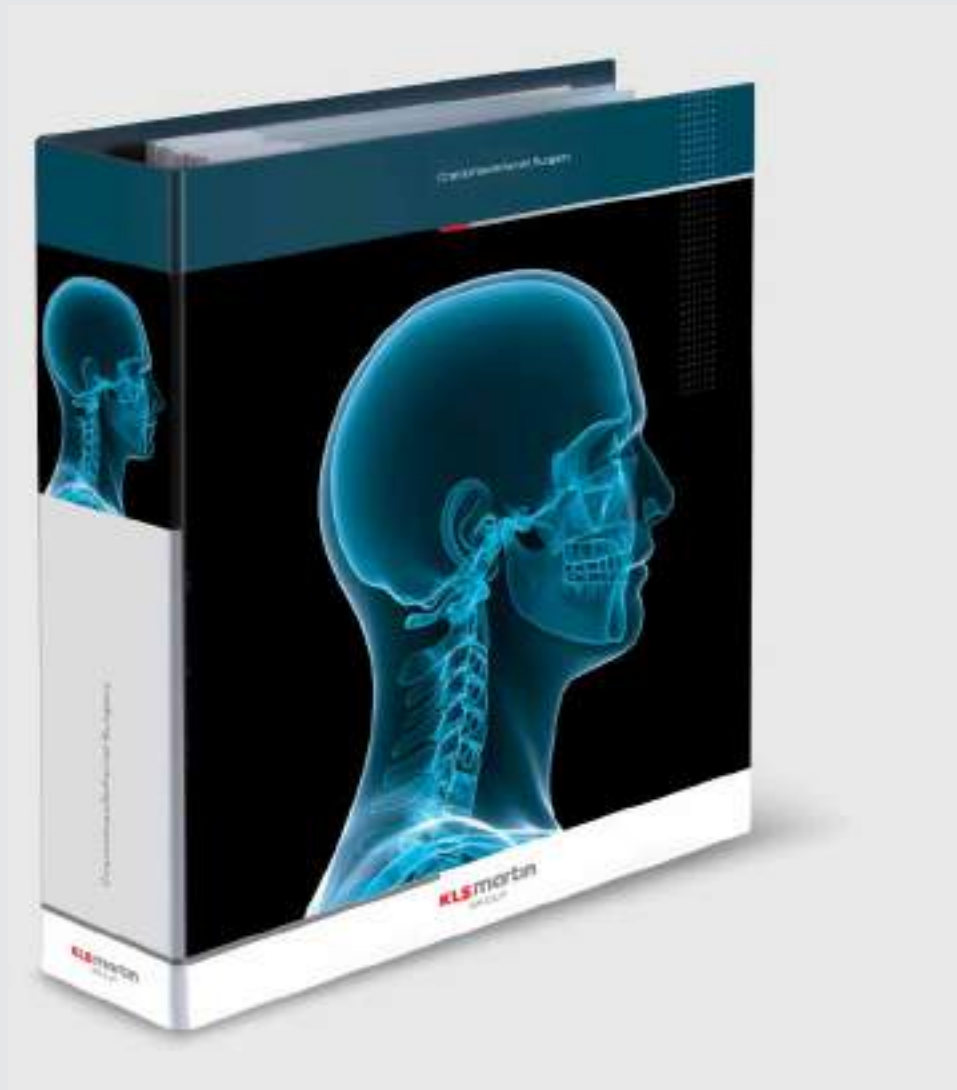
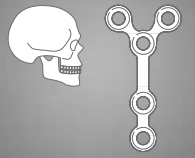

39

Tonsillektomie, Laryngo-Bronchoskopie
Tonsillectomy, Laryngo-Bronchoscopy
Tonsilectomía, Laringo-Bronchoscopia
Tonsillectomie, Laryngo-Bronchoscopie
Tonsilectomia, Laringo-Bronchoscopia

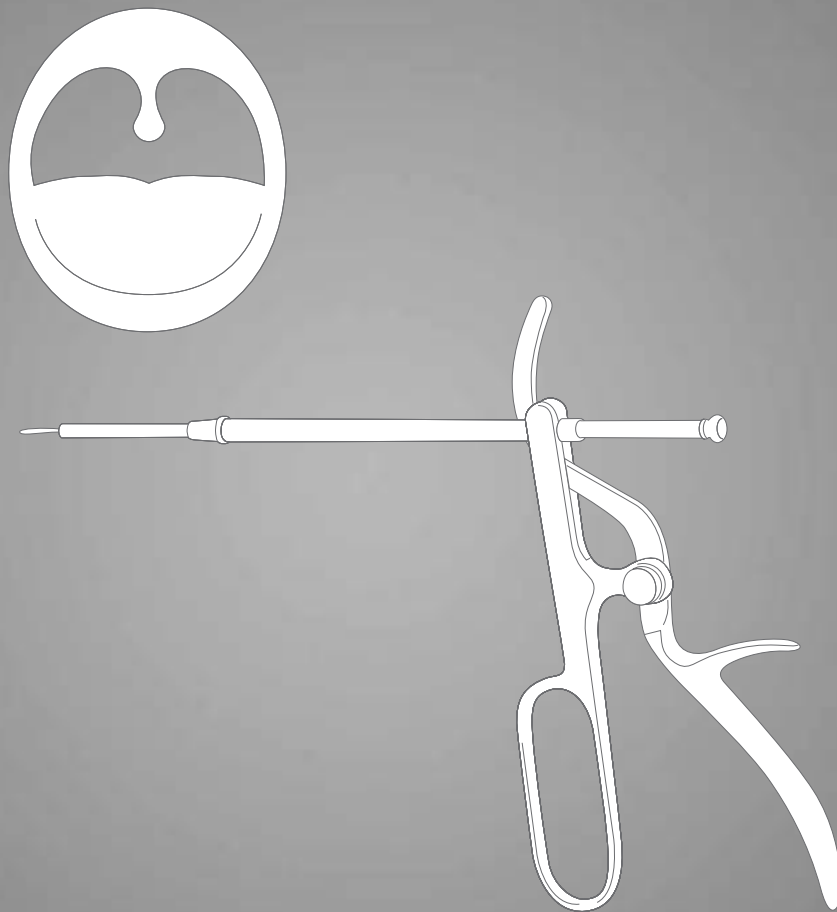

Gaumenspalten-Instrumente

Cleft Palate Instruments

Instrumentos paladares

Instruments pour palais

Strumenti per palato



1/2

Salyer

39-001-18-07 -
39-027-18-07

18 cm / 7 1/8"

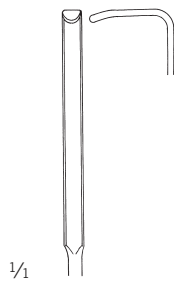

1/1

39-001-18-07

Gaumenspalten-Häkchen, kurz
Cleft Palate Hooklet, short
Ganchito para el paladar, corto
Crochet pour palais, court
Uncino per palato, corto

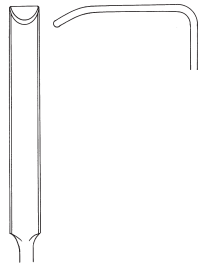

39-003-18-07

Gaumenspalten-Häkchen, lang
Cleft Palate Hooklet, long
Ganchito para el paladar, larga
Crochet pour palais, longue
Uncino per palato, lunga

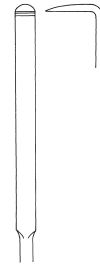

39-011-18-07

Gaumenspalten-Dissektor, kurz
Cleft Palate Dissector, short
Disecador para el paladar, corto
Dissecteur pour palais, court
Disettore per palato, corto

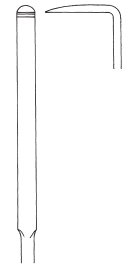

39-013-18-07

Gaumenspalten-Dissektor, lang
Cleft Palate Dissector, long
Disecador para el paladar, larga
Dissecteur pour palais, longue
Disettore per palato, lunga

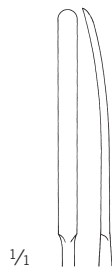

1/1

39-021-18-07

Gaumenspalten-Elevatorium
Cleft Palate Instruments
Instrumentos paladares
Instruments pour palais
Strumenti per palato



39-023-18-07

Gaumenspalten-Elevatorium
Cleft Palate Elevator
Elevador para el paladar
Élévateur pour palais
Elevatore per palato

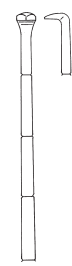

39-027-18-07

Gaumenspalten-Elevatorium, graduiert
Cleft Palate Elevator, graduated
Elevador para el paladar, graduado
Élévateur pour palais, gradué
Elevatore per palato, graduato



1/2

39-101-18-07 -
39-102-18-07

14 cm / 5 4/8"



1/1

39-101-18-07

links
left
izquierdo
gauche
sinistra



39-102-18-07

rechts
right
derecho
droit
destra

Tonsillennmesser, Tonsillenelevatorien Tonsillektomie, Laryngo-Bronchoskopie

Tonsil Knife, Tonsil Dissectors

Cuchillo, Disectores para amígdalas

Bistouri pour amygdales, Dissecteurs pour amygdales

Bisturi per tonsille, Disettori per tonsille

Tonsillectomy, Laryngo-Bronchoscopy

Tonsilectomía, Laringo-Bronchoscopía

Tonsillectomie, Laryngo-Bronchoscopie

Tonsilectomia, Laringo-Bronchoscopia

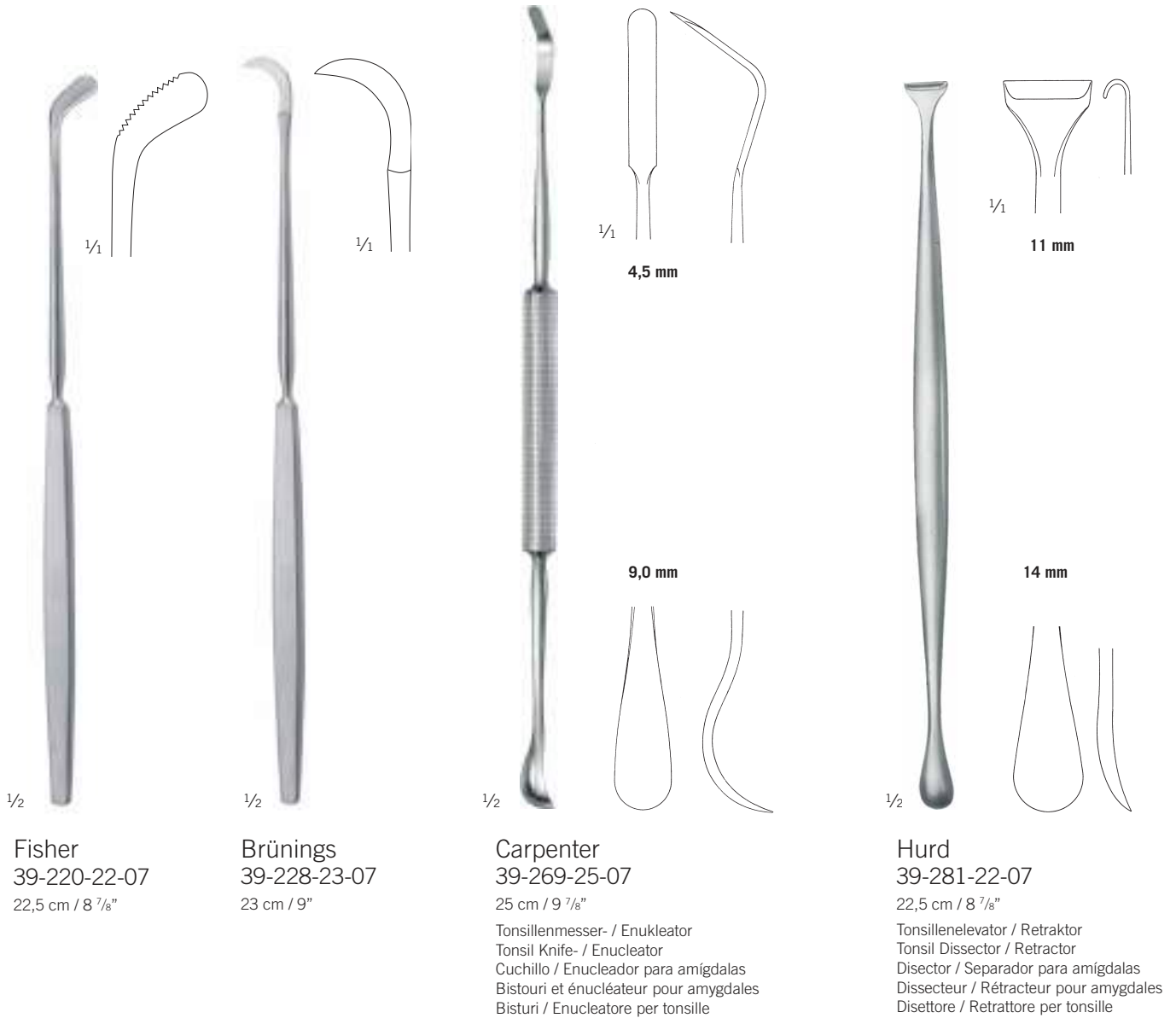
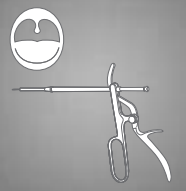

39

Tonsillenelevatorien, Tamponstopfer

Tonsil Dissectors, Gauze Packers

Disectores para amígdalas, Taponeadores

Dissecteurs pour amygdales, Porte-tampon

Disettori per tonsille, Tamponatori

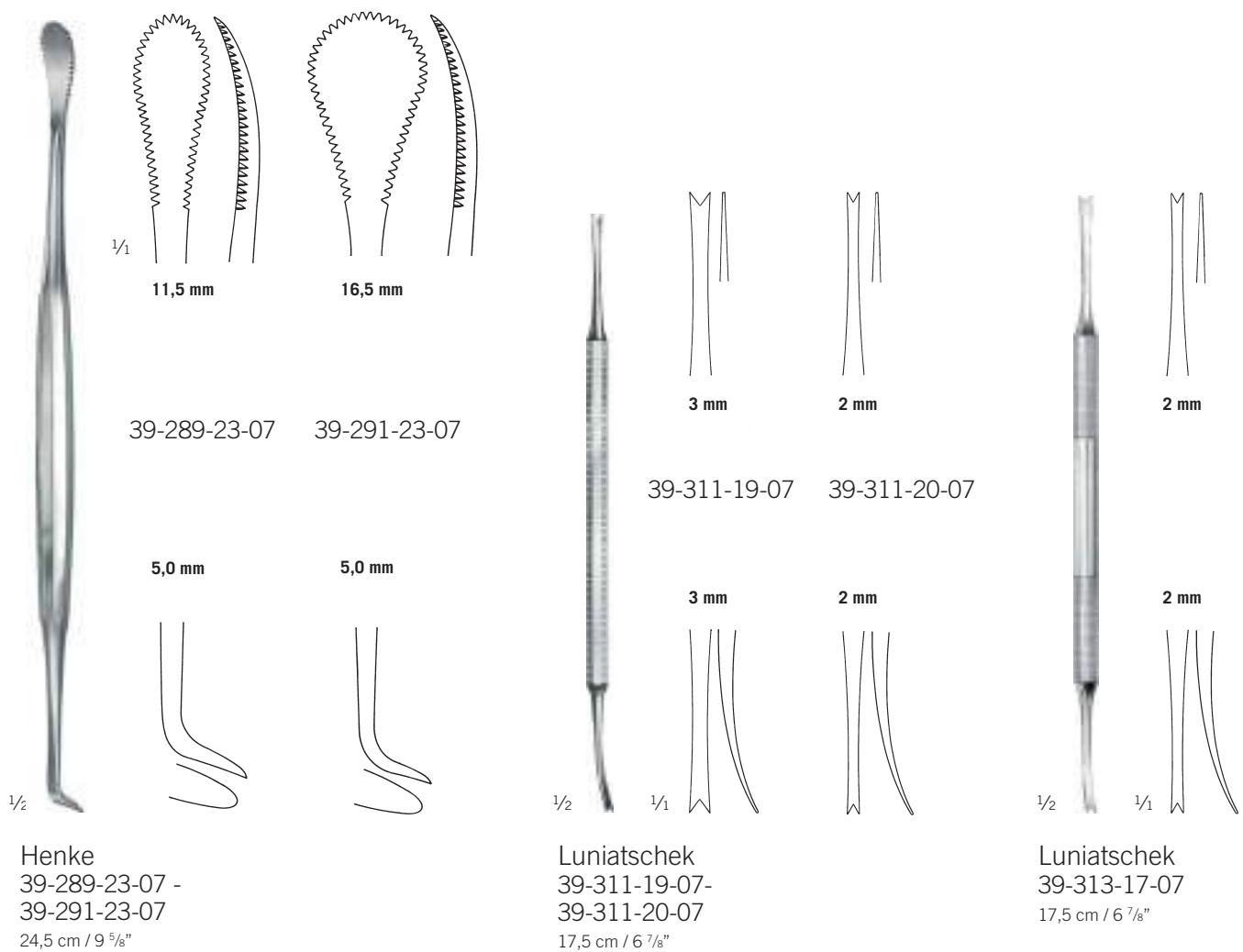

Tonsillenklemmen

Tonsil Forceps
Pinzas para amígdalas
Pincés pour amygdales
Pinze per tonsille

Tonsillektomie, Laryngo-Bronchoskopie

Tonsillectomy, Laryngo-Bronchoscopy
Tonsilectomía, Laringo-Bronhoscopia
Tonsillectomie, Laryngo-Bronhoscopie
Tonsilectomia, Laringo-Bronhoscopia

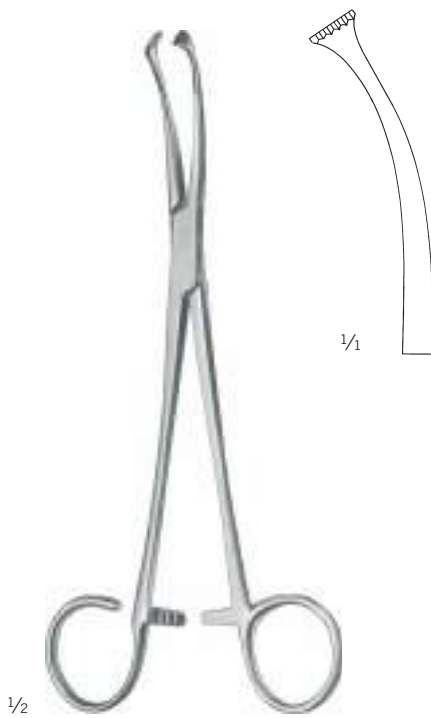

1/2

White
39-419-18-07
18 cm / 7 1/8"

Tonsillenfasszange
Tonsil Grasping Forceps
Pinza para amígdalas
Pince pour amygdales
Pinze per tonsille



1/2

Blohmke
39-423-20-07
20 cm / 7 1/8"

Tonsillenfasszange
Tonsil Grasping Forceps
Pinza para amígdalas
Pince pour amygdales
Pinze per tonsille



1/2

Schnidt
39-443-19-07 -
39-445-19-07

39-443-19-07
19 cm / 7 4/8"

39-445-19-07
18,5 cm / 7 2/8"



1/2

Schnidt
39-447-19-07 -
39-449-19-07

39-447-19-07
19 cm / 7 4/8"

39-449-19-07
18,5 cm / 7 2/8"

Tonsillenschnürer

Tonsil Snares

Cierra-nudos para amígdalas

Serre-noeuds pour amygdales

Serranodi per tonsille

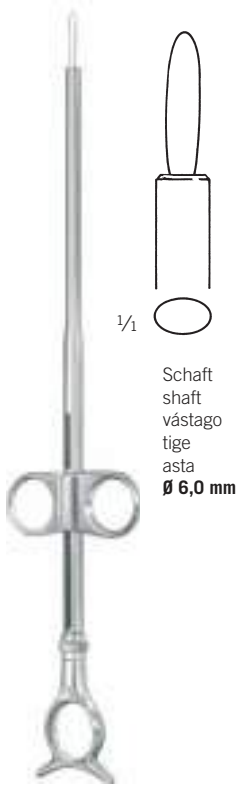

1/1

Schaft
shaft
vástago
tige
asta
Ø 6,0 mm



1/1

Schaft
shaft
vástago
tige
asta
Ø 6,0 mm



1/1

Schaftspitze
shaft tip
alto de vástago
pointe de tige
punta di asta
9,5 mm

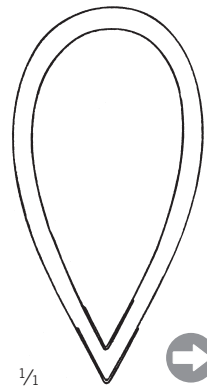

39-506-28-07

39-511-40-07
Ø 40 x 0,3 mm

39-511-50-07
Ø 50 x 0,3 mm

Eves
39-500-28-07
28,5 cm / 11 2/8"

ohne Raste
without ratchet
sin cremallera
sans cremaillère
senza cremagliera

Eves
39-502-28-07
28,5 cm / 11 2/8"

mit Raste
with ratchet
con cremallera
avec cremaillère
con cremagliera

Brünings
39-506-28-07
29 cm / 11 3/8"

mit Doppelraste
with double ratchet
con cremallera doble
avec cremaillère double
con cremagliera doppio

39-511-40-07 -
39-511-50-07

Schlinge, Packung mit 100 Stück
Wire Loop, package of 100 pieces
Asa de alambre, paquete con 100 piezas
Anse en fil, paquet avec 100 pièces
Laccio, confezione di 100 pezzi



39-500-28-07
39-502-28-07
39-525-01-07

Ø 0,3 mm
39-513-01-07

Schnürdraht, Packung mit 100 Stück
Snare Wire, package of 100 pieces
Alambre para asas, paquete con 100 piezas
Fil pour anses, paquet avec 100 pièces
Filo per legare, confezione di 100 pezzi

Tyding
39-525-01-07

mit einem geraden Aufsatz
with one straight tip
con una punta recta
avec une pointe droite
con una punta diritta



1/2

Broncho-Oesophagoskopiezangen

Broncho-Esophagocopy Forceps
Pinzas para Broncho-Esofagoscopia
Pincas pour Broncho-Esophagoscopie
Pinze per Broncho-Esofagoscopia

Laryngo-Bronchoskopie

Tonsillectomy, Laryngo-Bronchoscopy
Tonsilectomía, Laringo-Bronchoscopía
Tonsillectomie, Laryngo-Bronchoscopie
Tonsilectomia, Laringo-Bronchoscopia

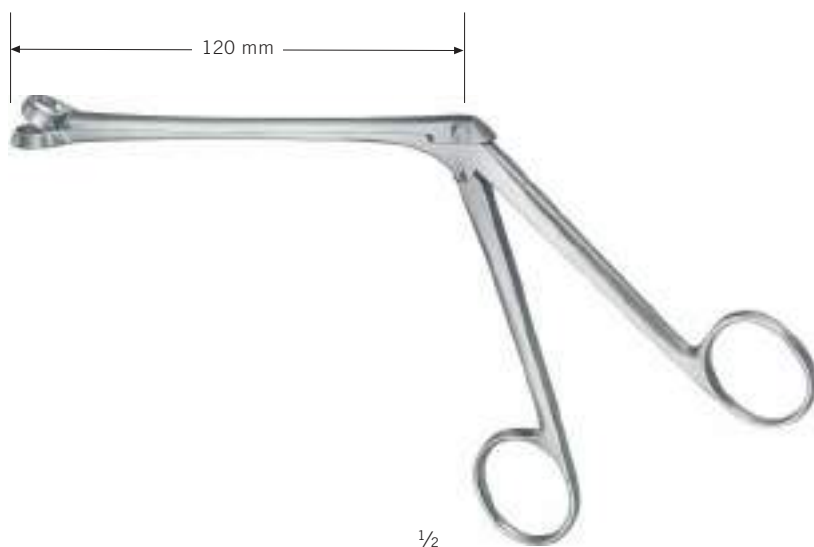
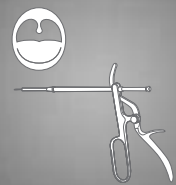

1/4

39-541-13-07

Schnitt
cut
corte
tranchant
tagliente
Ø 13 mm

Schaftlänge
shaft length
longitud del vástago
longueur de la tige
lunghezza dell'asta
120 mm

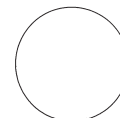

39-541-15-07

Schnitt
cut
corte
tranchant
tagliente
Ø 15 mm

Schaftlänge
shaft length
longitud del vástago
longueur de la tige
lunghezza dell'asta
120 mm

Hartmann
39-541-13-07 -
39-541-15-07

Tonsillenzange, durchschneidend
Tonsil Punchthrough-cutting
Pinzas para amígdalas, cortante
Pince pour amygdales, tranchante
Pinza per tonsille, tagliente



Brünings

39-584-20-07	22 cm / 8 5/8"
39-584-30-07	32 cm / 12 5/8"
39-584-40-07	41 cm / 16 1/8"

➔ 39-581-01-07



Huber
39-581-01-07

für Verlängerungsrohre 39-584-20-07 - 39-587-20-07
for interchangeable tubes 39-584-20-07 - 39-587-20-07
para tubos de extensión 39-584-20-07 - 39-587-20-07
pour tubes rallonges 39-584-20-07 - 39-587-20-07
per tubi allunghi 39-584-20-07 - 39-587-20-07



Brünings
39-587-20-07

18 cm / 7 1/8"

➔ 39-581-01-07

Auswechselbare Zangenaufsätze

Exchangeable Tips

Pinzas intercambiables

Embouts interchangeables

Pinze intercambiabili



Fraenkel
39-600-01-07

für Verlängerungsrohre 39-584-20-07 - 39-587-20-07
for interchangeable tubes 39-584-20-07 - 39-587-20-07
para tubos de extension 39-584-20-07 - 39-587-20-07
pour tubes rallonges 39-584-20-07 - 39-587-20-07
per tubi allunghi 39-584-20-07 - 39-587-20-07



Seiffert
39-604-01-07

für Verlängerungsrohre 39-584-20-07 - 39-587-20-07
for interchangeable tubes 39-584-20-07 - 39-587-20-07
para tubos de extension 39-584-20-07 - 39-587-20-07
pour tubes rallonges 39-584-20-07 - 39-587-20-07
per tubi allunghi 39-584-20-07 - 39-587-20-07



Fraenkel
39-608-01-07

für Verlängerungsrohre 39-584-20-07 - 39-587-20-07
for interchangeable tubes 39-584-20-07 - 39-587-20-07
para tubos de extension 39-584-20-07 - 39-587-20-07
pour tubes rallonges 39-584-20-07 - 39-587-20-07
per tubi allunghi 39-584-20-07 - 39-587-20-07



Scheinmann
39-611-01-07

für Verlängerungsrohre 39-584-20-07 - 39-587-20-07
for interchangeable tubes 39-584-20-07 - 39-587-20-07
para tubos de extension 39-584-20-07 - 39-587-20-07
pour tubes rallonges 39-584-20-07 - 39-587-20-07
per tubi allunghi 39-584-20-07 - 39-587-20-07



Scheinmann
39-613-01-07

für Verlängerungsrohre 39-584-20-07 - 39-587-20-07
for interchangeable tubes 39-584-20-07 - 39-587-20-07
para tubos de extension 39-584-20-07 - 39-587-20-07
pour tubes rallonges 39-584-20-07 - 39-587-20-07
per tubi allunghi 39-584-20-07 - 39-587-20-07



Brünings
39-616-02-07 - 39-616-03-07

für Verlängerungsrohre 39-584-20-07 - 39-587-20-07
for interchangeable tubes 39-584-20-07 - 39-587-20-07
para tubos de extension 39-584-20-07 - 39-587-20-07
pour tubes rallonges 39-584-20-07 - 39-587-20-07
per tubi allunghi 39-584-20-07 - 39-587-20-07



Fig. 2
39-616-02-07



Fig. 3
39-616-03-07



Brünings
39-618-02-07 - 39-618-03-07

für Verlängerungsrohre 39-584-20-07 - 39-587-20-07
for interchangeable tubes 39-584-20-07 - 39-587-20-07
para tubos de extension 39-584-20-07 - 39-587-20-07
pour tubes rallonges 39-584-20-07 - 39-587-20-07
per tubi allunghi 39-584-20-07 - 39-587-20-07



Fig. 2
39-618-02-07



Fig. 3
39-618-03-07



Lange
39-624-01-07

für Verlängerungsrohre 39-584-20-07 - 39-587-20-07
for interchangeable tubes 39-584-20-07 - 39-587-20-07
para tubos de extension 39-584-20-07 - 39-587-20-07
pour tubes rallonges 39-584-20-07 - 39-587-20-07
per tubi allunghi 39-584-20-07 - 39-587-20-07



Fig. 1
39-624-01-07

Auswechselbare Zangenaufsätze

Exchangeable Tips
Pinzas intercambiables
Embouts interchangeables
Pinze intercambiabili

Laryngo-Bronchoskopie

Tonsillectomy, Laryngo-Bronchoscopy
Tonsilectomía, Laringo-Broncoscopia
Tonsillectomie, Laryngo-Bronchoscopie
Tonsilectomia, Laringo-Bronchoscopia

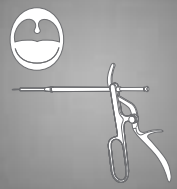

1/2

Krause

39-628-01-07 - 39-628-02-07

für Verlängerungsrohre 39-584-20-07 - 39-587-20-07
for interchangeable tubes 39-584-20-07 - 39-587-20-07
para tubos de extension 39-584-20-07 - 39-587-20-07
pour tubes rallonges 39-584-20-07 - 39-587-20-07
per tubi allunghi 39-584-20-07 - 39-587-20-07



Fig. 1
39-628-01-07



Fig. 2
39-628-02-07



1/1



1/1

Krause

39-632-01-07

für Verlängerungsrohre 39-584-20-07 - 39-587-20-07
for interchangeable tubes 39-584-20-07 - 39-587-20-07
para tubos de extension 39-584-20-07 - 39-587-20-07
pour tubes rallonges 39-584-20-07 - 39-587-20-07
per tubi allunghi 39-584-20-07 - 39-587-20-07



1/1

Cordes

39-637-01-07 - 39-637-04-07

für Verlängerungsrohre 39-584-20-07 - 39-587-20-07
for interchangeable tubes 39-584-20-07 - 39-587-20-07
para tubos de extension 39-584-20-07 - 39-587-20-07
pour tubes rallonges 39-584-20-07 - 39-587-20-07
per tubi allunghi 39-584-20-07 - 39-587-20-07



Fig. 1
39-637-01-07



Fig. 2
39-637-02-07



Fig. 3
39-637-03-07



Fig. 4
39-637-04-07



1/1



1/1

Schumacher

39-639-01-07

für Verlängerungsrohre 39-584-20-07 - 39-587-20-07
for interchangeable tubes 39-584-20-07 - 39-587-20-07
para tubos de extension 39-584-20-07 - 39-587-20-07
pour tubes rallonges 39-584-20-07 - 39-587-20-07
per tubi allunghi 39-584-20-07 - 39-587-20-07



1/1

Cordes

39-643-01-07 - 39-643-02-07

für Verlängerungsrohre 39-584-20-07 - 39-587-20-07
for interchangeable tubes 39-584-20-07 - 39-587-20-07
para tubos de extension 39-584-20-07 - 39-587-20-07
pour tubes rallonges 39-584-20-07 - 39-587-20-07
per tubi allunghi 39-584-20-07 - 39-587-20-07



Fig. 1
39-643-01-07



Fig. 2
39-643-02-07



1/1



1/1

Cordes

39-647-01-07

für Verlängerungsrohre 39-584-20-07 - 39-587-20-07
for interchangeable tubes 39-584-20-07 - 39-587-20-07
para tubos de extension 39-584-20-07 - 39-587-20-07
pour tubes rallonges 39-584-20-07 - 39-587-20-07
per tubi allunghi 39-584-20-07 - 39-587-20-07



1/1



1/1

Rosenberg

39-657-01-07

für Verlängerungsrohre 39-584-20-07 - 39-587-20-07
for interchangeable tubes 39-584-20-07 - 39-587-20-07
para tubos de extension 39-584-20-07 - 39-587-20-07
pour tubes rallonges 39-584-20-07 - 39-587-20-07
per tubi allunghi 39-584-20-07 - 39-587-20-07

Kehlkopfspiegel

Laryngeal Mirrors

Espejos laringeos

Miroirs laryngiens

Specchi laringei

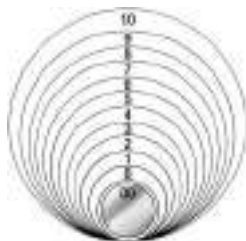

Fig. 00	39-781-08-01	Ø 8 mm
Fig. 0	39-781-10-01	Ø 10 mm
Fig. 1	39-781-12-01	Ø 12 mm
Fig. 2	39-781-14-01	Ø 14 mm
Fig. 3	39-781-16-01	Ø 16 mm
Fig. 4	39-781-18-01	Ø 18 mm
Fig. 5	39-781-20-01	Ø 20 mm
Fig. 6	39-781-22-01	Ø 22 mm
Fig. 7	39-781-24-01	Ø 24 mm
Fig. 8	39-781-26-01	Ø 26 mm
Fig. 9	39-781-28-01	Ø 28 mm
Fig. 10	39-781-30-01	Ø 30 mm

rhodiumbeschichtet rhodium plated cubierto de rodio plaqué du rhodium coperto di rodio		
Fig. 00	39-782-08-04	Ø 8 mm
Fig. 0	39-782-10-04	Ø 10 mm
Fig. 1	39-782-12-04	Ø 12 mm
Fig. 2	39-782-14-04	Ø 14 mm
Fig. 3	39-782-16-04	Ø 16 mm
Fig. 4	39-782-18-04	Ø 18 mm
Fig. 5	39-782-20-04	Ø 20 mm
Fig. 6	39-782-22-04	Ø 22 mm
Fig. 7	39-782-24-04	Ø 24 mm
Fig. 8	39-782-26-04	Ø 26 mm
Fig. 9	39-782-28-04	Ø 28 mm
Fig. 10	39-782-30-04	Ø 30 mm

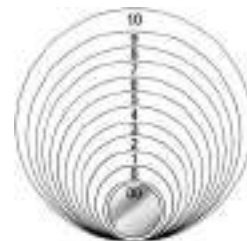

Fig. 00	39-785-08-01	Ø 8 mm
Fig. 0	39-785-10-01	Ø 10 mm
Fig. 1	39-785-12-01	Ø 12 mm
Fig. 2	39-785-14-01	Ø 14 mm
Fig. 3	39-785-16-01	Ø 16 mm
Fig. 4	39-785-18-01	Ø 18 mm
Fig. 5	39-785-20-01	Ø 20 mm
Fig. 6	39-785-22-01	Ø 22 mm
Fig. 7	39-785-24-01	Ø 24 mm
Fig. 8	39-785-26-01	Ø 26 mm
Fig. 9	39-785-28-01	Ø 28 mm
Fig. 10	39-785-30-01	Ø 30 mm

rhodiumbeschichtet rhodium plated cubierto de rodio plaqué du rhodium coperto di rodio		
Fig. 00	39-786-08-04	Ø 8 mm
Fig. 0	39-786-10-04	Ø 10 mm
Fig. 1	39-786-12-04	Ø 12 mm
Fig. 2	39-786-14-04	Ø 14 mm
Fig. 3	39-786-16-04	Ø 16 mm
Fig. 4	39-786-18-04	Ø 18 mm
Fig. 5	39-786-20-04	Ø 20 mm
Fig. 6	39-786-22-04	Ø 22 mm
Fig. 7	39-786-24-04	Ø 24 mm
Fig. 8	39-786-26-04	Ø 26 mm
Fig. 9	39-786-28-04	Ø 28 mm
Fig. 10	39-786-30-04	Ø 30 mm



1/2

39-781-08-01 -
39-782-30-04

18,5 cm / 7 2/8"
plan, mit festem Handgriff
plane, with fixed handle
plano, con mango fijado
plat, avec manche fixe
plano, con manico fisso



1/2

39-785-08-01 -
39-786-30-04

13,5 cm / 5 3/8"
plan, ohne Handgriff
plane, without handle
plano, sin mango
plat, sans manche
plano, senza manico

Kehlkopfspiegel -und Griffe

Laryngeal Mirrors, Laryngeal Mirror Handles
Espejos laringeos, Mangos para espejos laringeos
Miroirs laryngiens, Manche pour miroirs laryngiens
Specchi laringei, Manico per specchi laringei

Tonsillektomie, Laryngo-Bronchoskopie

Tonsillectomy, Laryngo-Bronchoscopy
Tonsilectomía, Laringo-Broncoscopia
Tonsillectomie, Laryngo-Bronchoscopie
Tonsilectomia, Laringo-Bronchoscochia

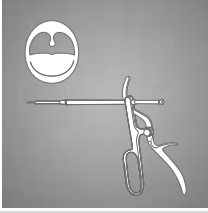

Cr



Fig. 1 39-789-12-02 Ø 12 mm
Fig. 2 39-789-14-02 Ø 14 mm



Fig. 3 39-789-16-02 Ø 16 mm
Fig. 4 39-789-18-02 Ø 18 mm



39-794-11-02 11 cm / 4 4/8"
39-798-12-02 12,5 cm / 4 7/8"

➔ 39-785-08-01 - 39-786-30-04
➔ 39-785-08-01 - 39-786-30-04

Michel
39-789-12-02 -
39-789-18-02
27 cm / 10 5/8"
beweglicher Spiegel
moveable mirror
espejo movable
miroir mobile
specchio mobile

39

Kehlkopfpolypenzangen

Laryngeal Polypus Forceps

Pinzas para pólipos laringeos

Pinces pour polypes laryngiens

Pinze per polipi laringei



Fig. 1
39-814-01-07



Fig. 2
39-814-02-07



Fig. 3
39-814-03-07



Fig. 4
39-814-04-07



1/2

Jurasz
39-814-01-07 -
39-814-04-07
23 cm / 9"

Dental, Oral

40-47

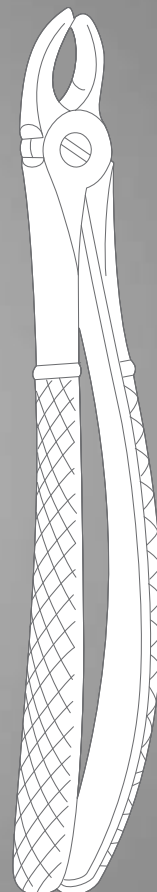
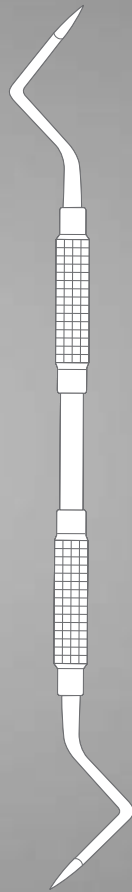
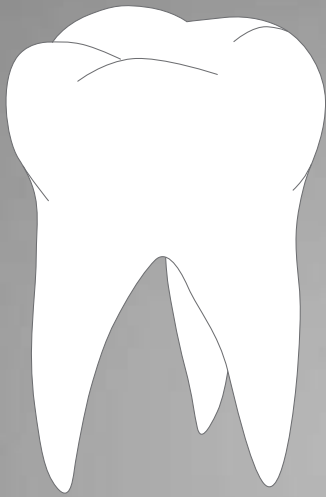

Spezial-Produkte

Special Products

Productos especiales

Produits spéciaux

Prodotti speciali

Unser Katalog „Dental/Oral“ enthält die gesamte Palette der KLS-Martin-Dental-Instrumente.

Our catalog “Dental/Oral” contains the full range of KLS-Martin dental instruments.

Nuestro catálogo “Dental/Oral” incluye la gama completa de instrumentos dentales de KLS-Martin.

Notre catalogue «Dental/Oral» contient l'ensemble de la palette des instruments dentaires KLS Martin.

Il nostro catalogo “Dental/Oral” contiene la gamma completa degli strumenti dentali di KLS Martin.



Verschiedenes
Miscellaneous
Diversos artículos
Articles divers
Articoli diversi

54-73

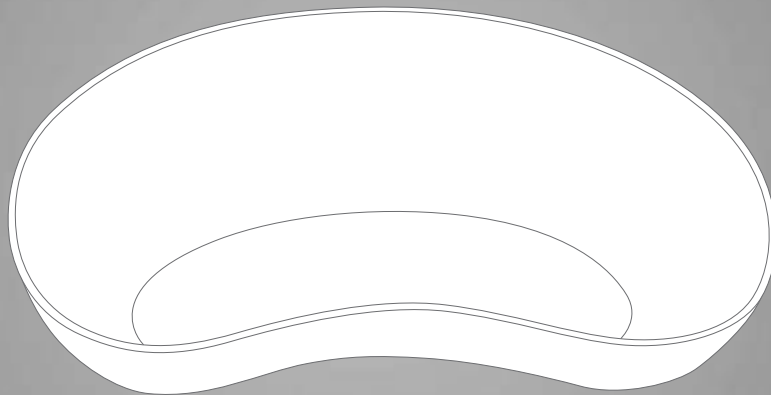

Handwaschbürste, Bürstenspender

Hand and Nail Brush, Brush Dispensers
Cepillo para uñas, Dispensadores de cepillos
Brosse à ongles, Distributeurs de brosses
Spazzola per unghie, Distributore per spazzole

St
18/8



Martin-Aseptic 54-100-01-04

110 x 40 x 35 mm (l x b x h)

Kunststoff, mehr als 400 x autoklavierbar
plastic, more than 400 x autoclavable
plástico, más que 400 x autoclavable
matière plastique, stérilisable à autoclave 400 fois et plus
plastico, sterilizzabile più di 400 volte in autoclave

Martin 54-150-10-01

265 x 165 x 65 mm

für 10 Bürsten (ohne Bürsten)
for 10 brushes (without brushes)
para 10 cepillos (sin cepillos)
pour 10 brosses (sans brosses)
per 10 spazzole (senza spazzole)

mit Aufhängevorrichtung
with suspension
con suspensión
avec suspension
con suspensioe



Martin 54-150-20-01

275 x 240 x 65 mm

für 20 Bürsten (ohne Bürsten)
for 20 brushes (without brushes)
para 20 cepillos (sin cepillos)
pour 20 brosses (sans brosses)
per 20 spazzole (senza spazzole)

mit Aufhängevorrichtung
with suspension
con suspensión
avec suspension
con suspensioe

Zubehör für Bürstenspender

Accessories for Brush Dispensers

Accesorios para dispensadores de cepillos

Accessoires pour distributeurs de brosses

Assessori per distributore per spazzole

Verschiedenes

Miscellaneous

Diversos artículos

Articles divers

Articoli diversi



St
18/6



54-155-25-04

Kunststoff
plastic
plástico
plastique
plastico



54-150-10-01, 54-150-20-01

54-160-20-01

Bürstenabwurfbehälter
Brush Collecting Box
Recipiente de descarga
para cepillos
Boîte pour déposer
les brosses à ongles
Contenitore per spazzole usate

mit Aufhängevorrichtung
with suspension
con suspensión
avec suspension
con suspensioe

54-
73

Nagelscheren, Nagelzangen

Nail Scissors
Tijeras para uñas
Ciseaux à ongles
Forbici per unghie



1/2

54-301-10-07

Nagelschere und Nagelfeile an Kette
nail scissors and nail file with chain
tijeras y lima para uñas con cadena
ciseaux à ongles et lime à ongles avec chaîne
forbici e lima per unghie con catena



1/2

54-305-10-07

10,5 cm / 4 1/8"



1/2

54-331-14-07

14 cm / 5 4/8"



1/2

54-336-14-07

14 cm / 5 4/8"

54-336-16-07

16 cm / 6 2/8"



1/2

Turnbull

54-341-11-07

12 cm / 4 6/8"

54-341-13-07

13 cm / 5 1/8"



1/2

54-347-13-07

14 cm / 5 4/8"



1/2

54-353-12-07

12 cm / 4 6/8"

Nageleckenzangen, Nagelhautzangen, Hautscheren, Nagelfeilen

Nail Nippers, Cuticle Nippers, Cuticle Scissors, Nail Files

Pinzas para cortar uñas, Pinzas cuticulares, Tijeras cuticulares, Limas para uñas

Pinces pour couper ongles, Pinces à envies, Ciseaux à envies, Limes à ongles

Tronchesine per unghie, Tronchesine per pelle, Forbici per pelle, Lime per unghie

Verschiedenes
Miscellaneous
Diversos artículos
Articles divers
Articoli diversi



1/2

54-360-11-07 10 cm / 3 7/8"
54-360-13-07 13 cm / 5 1/8"
54-360-15-07 15 cm / 5 7/8"

gerade Schneiden
straight cutting edges
hojas cortantes rectas
lames tranchantes droites
parte tagliente diritta



1/2

54-365-11-07 11 cm / 4 3/8"
54-365-13-07 13 cm / 5 1/8"



1/2

54-373-10-07
11 cm / 4 3/8"
feines Modell
delicate pattern
modelo delicado
modèle fin
modello fino



1/2

54-378-10-07 10,5 cm / 4 1/8"
54-378-12-07 11,5 cm / 4 4/8"
feines Modell
delicate pattern
modelo delicado
modèle fin
modello fino

54-73



1/2

54-379-10-07 10,5 cm / 4 1/8"
54-379-12-07 11,5 cm / 4 4/8"
feines Modell
delicate pattern
modelo delicado
modèle fin
modello fino



1/2

54-386-10-07
9 cm / 3 4/8"



1/2

54-388-11-07
11 cm / 4 3/8"



1/2

54-389-16-04
16 cm / 6 2/8"
Saphirbelag
sapphire coating
recubrimiento de zafiro
couche en saphir
rivestimento in zaffiro

Infektions-Schutzbrillen, Gesichtsschutz

Protection Spectacles, Face Protection Mask

Gafas protectoras, Protector de cara

Lunettes protectrices, Protecteur facial

Occhiali protettivi, Protettore faciale



Zeller
54-406-00-04



Mod. Martin
54-410-01-04



54-410-05-04
Schutzschild
Protecting Shield
Protector suelta
Masque protectrice
Maschera protettrice

➔ 54-410-01-04

54-410-06-04
Stirnreif
Head Band
Cinta frontal
Bandeau frontal
Cinta frontale sola

➔ 54-410-01-04

Verschiedenes
Miscellaneous
Diversos artículos
Articles divers
Articoli diversi

55

Unser Katalog „Steriltechnik“ enthält die gesamte Palette der KLS-Martin-Sterilisationscontainer- und Siebkorbssysteme.

Our catalog “Sterile Technology” contains the full range of KLS-Martin sterilizing containers and perforated sterilization baskets.

Nuestro catálogo “Técnica de esterilización” incluye la gama completa de contenedores de esterilización y sistemas de bandejas cribadas de KLS-Martin.

Notre catalogue «Technologie stérile» contient l'ensemble de la palette des conteneurs de stérilisation et paniers à mailles KLS Martin.

Il nostro catalogo “Tecnica di sterilizzazione” contiene la gamma completa dei sistemi di contenitori di sterilizzazione e vassoi reticolati di KLS Martin.

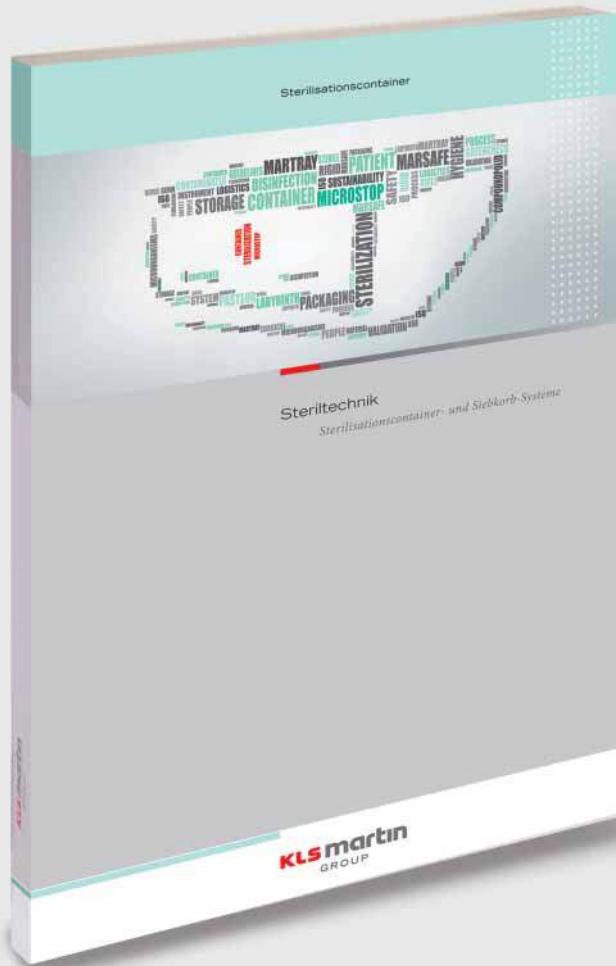

54-
73

Sterilisierzangen, Petrischalengestell

Sterilizing Forceps, Storage Rack for Petri Dishes

Pinzas para esterilización, Caballete para cápsulas de Petri

Pinces pour instruments stérilisés, Support pour boîtes de Petri

Pinze per strumenti sterilizzati, Supporti per piatti Petri



1/3

Cheattle
55-085-27-07
27 cm / 10 5/8"



1/3

55-091-30-07
30 cm / 11 6/8"



ca. 1/3

55-141-10-01

für bis zu 10 Schalen mit Ø 8 - 10 cm,
mit Fixiervorrichtung

for up to 10 dishes of Ø 8 - 10 cm,
with fixation device

para hasta 10 cápsulas de Ø 8 - 10 cm,
con dispositivo de fijación

pour jusqu'à 10 boîtes de Ø 8 - 10 cm,
avec dispositif de fixation

per fina a 10 bucce da Ø 8 - 10 cm,
con dispositivo di fissazione

St
18/8



ca. 1/3

55-142-10-01

für bis zu 10 Schalen mit Ø 8 - 10 cm,
mit Fixiervorrichtung

for up to 10 dishes of Ø 8 - 10 cm,
with fixation device

para hasta 10 cápsulas de Ø 8 - 10 cm,
con dispositivo de fijación

pour jusqu'à 10 boîtes de Ø 8 - 10 cm,
avec dispositif de fixation

per fina a 10 bucce da Ø 8 - 10 cm,
con dispositivo di fissazione

Nadeldosen

Needle Cases

Estuches para agujas

Boîtes pour aiguilles

Scatole per aghi

Verschiedenes

Miscellaneous

Diversos artículos

Articles divers

Articoli diversi



ca. 1/3

Sauerbruch
55-162-20-01

210 x 125 x 17 mm

Deckel und Boden perforiert
perforated lid and bottom
tapa y fondo perforado
couverture et fond perforé
coperchio e fondo perforati



ca. 1/3

Sauerbruch
55-164-20-01

210 x 125 x 17 mm

Deckel und Boden perforiert
perforated lid and bottom
tapa y fondo perforado
couverture et fond perforé
coperchio e fondo perforati

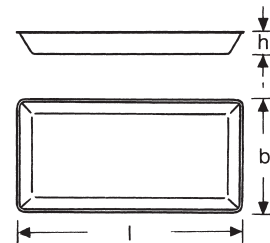

55-300-50-01 50 x 25 x 4,5 mm

55-300-65-01 65 x 42 x 8 mm

55-300-75-01 75 x 25 x 4,5 mm

55-302-50-01 50 x 25 x 4,5 mm

55-302-65-01 65 x 42 x 8 mm

55-302-75-01 75 x 25 x 4,5 mm

54-
73

Nadeldosen

Needle Cases

Estuches para agujas

Boîtes pour aiguilles

Scatole per aghi

St
18/6



1/2

55-309-65-01

h = 18 mm Ø 67 mm

komplett mit perforierter Innendose
complete with perforated interior box
completa con caja interior perforada
complet avec boîte intérieure perforée
completo con scatola interiore perforata

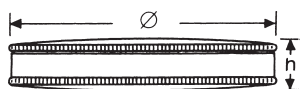

1/4

55-310-65-01

h = 15 mm Ø 61 mm

Innendose, Deckel und Boden perforiert
Interior Box, perforated lid and bottom
Caja interior, tapa y fondo perforado
Boîte intérieure, couvercle et fond perforé
Scatola per aghi, coperchio e fondo perforati

55-335-01-01

150 x 95 x 13 mm



1/4

55-335-02-01

150 x 95 x 13 mm

Deckel und Boden perforiert
perforated lid and bottom
tapa y fondo perforado
couvercle et fond perforé
coperchio e fondo perforati



1/4

55-335-03-01

150 x 95 x 13 mm

Boden perforiert
perforated bottom
fondo perforado
fond perforé
fondo perforato



1/4

55-335-05-01

150 x 95 x 13 mm

Deckel und Boden perforiert
perforated lid and bottom
tapa y fondo perforado
couvercle et fond perforé
coperchio e fondo perforati

Nadelkassetten, Bereitstellungsbecher

Needle Cases, Storing Cup

Estuches para agujas, Tarro para instrumentos

Boîtes pour aiguilles, Goblet pour instruments

Scatole per aghi, Contenitore per strumenti

Verschiedenes

Miscellaneous

Diversos artículos

Articles divers

Articoli diversi



St
18/8



1/4

55-337-01-01

150 x 95 x 13 mm



1/4

55-337-02-01

150 x 95 x 13 mm

Deckel und Boden perforiert
perforated lid and bottom
tapa y fondo perforado
couvricle et fond perforé
coperchio e fondo perforati



1/4

55-340-02-01

150 x 95 x 11 mm

Nadelschale, Boden perforiert
Needle Tray, perforated bottom
Bandeja para agujas, fondo perforado
Boîte pour aiguilles, fond perforé
Scatola per aghi, fondo perforati



55-348-00-01

h = 75 mm Ø 75 mm

für Mikroinstrumente, mit auswechselbarer Silikon-Bodenplatte
for micro instruments, with exchangeable silicone plate
para micro instrumentos, con plaquita de silicona cambiabile
pour micro instruments, avec plaque de fond en silicone interchangeable
per micro strumenti, con stuoia di silicone intercambiabile



55-348-01-01

Silikoneinlage
Silicone plate
Plaquita de silicona
Plaque de silicone
Stuoia in silicone



55-348-00-01

54-
73

Kappenzangen, Sterilisierklammer

Dressing Forceps in jar with cap, Safety Pins

Pinza en tarro con tapa, Imperdibles para instrumentos

Combinaison couvercle/pinçe, Clips de stérilisation

Pinza-coperchio, Pinze per sterilizzazione

St
18/6



1/3

Mod. Martin
55-358-25-01

Standgefäß 20,5 cm hoch,
mit 25 cm langer Kornzange

jar 20,5 cm high,
with 25 cm long dressing forceps

tarro 20,5 cm de altura,
con pinza de vendaje de 25 cm

goblet 20,5 cm de hauteur,
avec pince à pansement de 25 cm longueur

contenitore 20,5 cm di altezza,
con pinza per medicatura di 25 cm di lunghezza



Mod. Martin
55-358-32-01

Standgefäß 25,5 cm hoch,
mit 32 cm langer Kornzange

jar 25,5 cm high,
with 32 cm long dressing forceps

tarro 25,5 cm de altura,
con pinza de vendaje de 32 cm

goblet 25,5 cm de hauteur,
avec pince à pansement de 25 cm longueur

contenitore 25,5 cm di altezza,
con pinza per medicatura di 32 cm di lunghezza



1/2

Mayo
55-805-14-01
14 cm / 5 4/8"



1/2

Mayo
55-808-14-01
14 cm / 5 4/8"

Verschiedenes
Miscellaneous
Diversos artículos
Articles divers
Articoli diversi

56

Metallschalen, Messbecher

Stainless Steel Bowls, Measurers

Cubetas de acero inoxidable, Caso-medidas

Cuvettes de acier inoxydable, Mesures graduées

Scodelle di acciaio inossidabile, Bicchieri graduati

St
18/8



	Ø x h	
56-176-33-01	Ø 330 mm x 90 mm	6.000 ccm
56-178-33-01	Ø 330 mm x 115 mm	8.000 ccm



	Ø x h	
56-231-04-01	Ø 40 x 19 mm	20 ccm
56-231-06-01	Ø 61 x 30 mm	70 ccm
56-231-08-01	Ø 80 x 40 mm	140 ccm
56-231-11-01	Ø 116 x 50 mm	250 ccm
56-231-12-01	Ø 128 x 55 mm	350 ccm
56-231-14-01	Ø 147 x 65 mm	500 ccm
56-231-16-01	Ø 167 x 75 mm	900 ccm
56-231-18-01	Ø 187 x 85 mm	1.300 ccm



	Ø x h	
56-235-11-01	Ø 116 x 35 mm	200 ccm
56-235-12-01	Ø 128 x 38 mm	300 ccm
56-235-14-01	Ø 147 x 50 mm	400 ccm
56-235-16-01	Ø 167 x 45 mm	500 ccm
56-235-18-01	Ø 187 x 45 mm	800 ccm



innen graduiert graduated inside graduado interiormente gradué intérieurment graduato all'interno
56-254-01-01 = 100 ccm



innen graduiert graduated inside graduado interiormente gradué intérieurment graduato all'interno
56-256-02-01 = 250 ccm
56-256-05-01 = 500 ccm
56-256-10-01 = 1.000 ccm
56-256-20-01 = 2.000 ccm

Mehrzweckschalen

Universal Trays
Bandejas universales
Plateaux universaux
Bacinelle universali

Verschiedenes

Miscellaneous
Diversos artículos
Articles divers
Articoli diversi



St
18/8

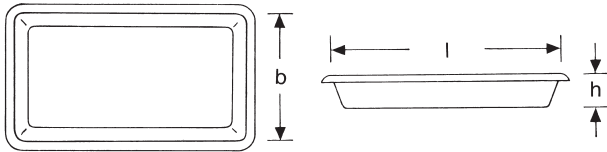

l x b x h

56-321-23-01	= 230 x 155 x 30 mm
56-321-30-01	= 300 x 175 x 30 mm
56-321-31-01	= 300 x 175 x 40 mm
56-321-35-01	= 350 x 240 x 40 mm
56-321-40-01	= 470 x 320 x 50 mm

l x b x h

56-324-21-01	= 210 x 160 x 11 mm
56-324-24-01	= 240 x 180 x 8 mm
56-324-30-01	= 310 x 150 x 11 mm
56-324-31-01	= 310 x 160 x 11 mm
56-324-35-01	= 350 x 235 x 10 mm
56-324-40-01	= 425 x 290 x 18 mm
56-324-42-01	= 400 x 300 x 12 mm

54-
73



l x b x h

56-340-23-01	= 235 x 190 x 40 mm
--------------	---------------------



Ø x h

56-348-22-01	= Ø 220 mm x 70 mm
--------------	--------------------

Standgefäße, Instrumentenkästen

Metal Jars, Instrument Boxes

Tarros metálicos, Cajas para instrumentos

Récipients en métal, Boîtes pour instruments

Recipienti metallici, Scatole per strumenti



	Ø x h
56-360-30-01	= 30 mm x 90 mm
56-360-50-01	= 50 mm x 100 mm
56-360-51-01	= 50 mm x 130 mm
56-360-52-01	= 50 mm x 175 mm
56-360-75-01	= 75 mm x 100 mm
56-360-76-01	= 75 mm x 130 mm
56-360-77-01	= 75 mm x 175 mm
56-360-98-01	= 100 mm x 175 mm
56-360-99-01	= 100 mm x 200 mm

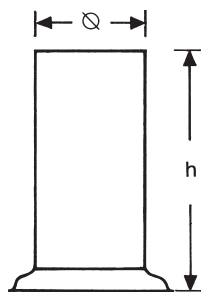

mit Knopfdeckel
lid with knob
tapa con botón
avec couvercle à bouton
con coperchio a bottone

	l x b x h
56-411-16-01	= 165 x 85 x 35 mm
56-411-20-01	= 200 x 100 x 35 mm
56-411-21-01	= 200 x 100 x 50 mm
56-411-23-01	= 230 x 130 x 50 mm
56-411-26-01	= 260 x 150 x 50 mm
56-411-27-01	= 270 x 235 x 50 mm
56-411-30-01	= 300 x 200 x 50 mm
56-411-33-01	= 325 x 275 x 50 mm

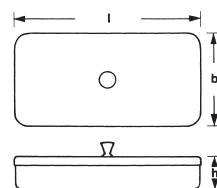

	l x b x h
56-419-20-01	= 205 x 105 x 40 mm

Runde Metalldosen, Nierenschale

Round Metal Boxes, Kidney Dishes

Cajas metálicas redondas, Riñoneras

Boîtes pour instruments, Bassins réniformes

Scatole per strumenti, Bacinelle reniformi

Verschiedenes

Miscellaneous

Diversos artículos

Articles divers

Articoli diversi



St
18/8



	Ø x h
56-431-06-01	= 100 mm x 60 mm
56-431-10-01	= 100 mm x 100 mm
56-432-08-01	= 125 mm x 80 mm
56-432-12-01	= 125 mm x 125 mm
56-435-15-01	= 150 mm x 150 mm

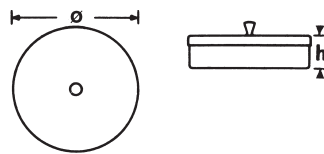

Nierenschalen-Deckel
Lid for Kidney Dishes
Tapa para riñoneras
Couvercle pour bassins réniformes
Coperchio per bacinelle reniformi

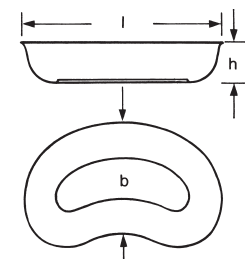

	l x b x h		
56-673-17-01	= 170 x 100 x 35 mm	300 ccm	—
56-673-25-01	= 250 x 140 x 40 mm	800 ccm	56-675-25-01
56-673-27-01	= 275 x 150 x 45 mm	1200 ccm	—

54-73

Verschiedenes
Miscellaneous
Diversos artículos
Articles divers
Articoli diversi

73

Wasserstrahl-Reinigungspistole

Water Jet Pistol

Pistola-lavatoria de chorro de agua

Pistolet-laveur à jet d'eau

Pistola lavatrice a getto d'acqua



Martin aquajet 73-101-00-04

komplett, mit 9 Aufsätzen 73-101-01-04 bis 73-101-09-04,
1 m Druckschlauch, Haken und Schelle

complete, with 9 tips 73-101-01-04 to 73-101-09-04,
1 m pressure tube, strap and suspension hook

completo, con 9 toberas 73-101-01-04 a 73-101-09-04,
1 m tubo de presión, abrazadera y gancho de
suspensión

complet, avec 9 embouts 73-101-01-04 à 73-101-09-04,
1 m de tuyau à haute pression, agrafe de serrage et
crochet de suspension

completa, con 9 raccordi 73-101-01-04 sino 73-101-09-04
1 m tubo ad alta pressione, graffa e gancio di sospensione

Martin aquajet 73-101-20-04

allein
only
suelto
seul
solo



Aufsätze
tips
toberas
embouts
raccordi



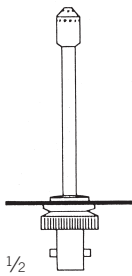

73-101-01-04

Fig. 1

für Flaschen
for bottles
para botellas
pour bouteilles
per bottiglie



73-101-02-04

Fig. 2

für Record-Spritzen Konen
for cones of record-syringes
para conos de jeringas
Record
pour raccords de seringues
Record
per coni di siringhe Record

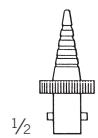

73-101-03-04

Fig. 3

für Katheter
for catheters
para catéteres
pour sondes
per cateteri



73-101-04-04

Fig. 4

für Drainageschläuche
for drainage tubings
para tubos de drenaje
pour sondes à drainage
per tubi di drenaggio

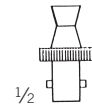

73-101-05-04

Fig. 5

für Hohlgefäße
for receptacles
para recipientes
pour vases
per recipienti



73-101-06-04

Fig. 6

für Kanülen mit Record-Konus
for hypodermic needles
with Record-cone
para agujas de inyección
con cono Record
pour aiguilles hypodér-
miques, raccord Record
per aghi ipodermici
con cono Record

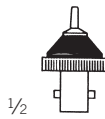

73-101-07-04

Fig. 7

für Kanülen mit Luer-Konus
for hypodermic needles
with Luer-cone
para agujas de inyección
con cono Luer
pour aiguilles hypodérmi-
ques, raccord Luer
per aghi ipodermici
con cono Luer



73-101-08-04

Fig. 8

für Meß- und Vollpipetten
for measuring and volume-
tric pipettes
para pipetas de medida
y volumétricas
pour pipettes ordinaires
et de précision
per pipette comuni
e graduate

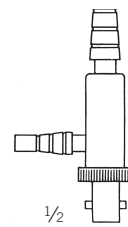

73-101-09-04

Fig. 9

für feine Pipetten
for fine pipettes
para pipetas finas
pour pipettes fines
per pipette fine



73-102-02-04

Überwurfmutter
Coupling
Tuerca-hembra
Ecrou-raccord
Dado premistoppa
1/2 Zoll
1/2 inch
1/2 pulgada
1/2 pouces
1/2 pollici

73-102-03-04

3/4 Zoll
3/4 inch
3/4 pulgada
3/4 pouces
3/4 pollici

Reinigungsbürsten

Cleaning Brushes

Cepillos de limpieza

Brosses à lavement

Spazzole per pulire

Nylonborsten
Nylon bristles
Cerdas de nailon
Poils nylon Scovolino
in nylon

Naturborsten
Natural bristles
Cerdas naturales
Poils naturels
Scovolino naturale

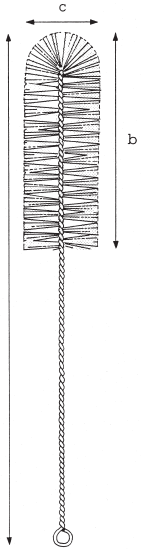

	73-301-03-04	73-303-03-04	73-304-07-04	73-306-08-04
a x b x c	250 x 70 x 3 mm	425 x 70 x 3 mm	285 x 75 x 7 mm	270 x 65 x 8 mm

Naturborsten
Natural bristles
Cerdas naturales
Poils naturels
Scovolino naturale



73-306-12-04	73-306-13-04	73-306-15-04	73-308-20-04	73-308-25-04	73-308-30-04
270 x 65 x 12 mm	230 x 60 x 13 mm	205 x 60 x 15 mm	215 x 65 x 20 mm	215 x 65 x 25 mm	215 x 65 x 30 mm

Reinigungsbürsten

Cleaning Brushes
Cepillos de limpieza
Brosses à lavement
Spazzole per pulire

Verschiedenes

Miscellaneous
Diversos artículos
Articles divers
Articoli diversi



Naturborsten
Natural bristles
Cerdas naturales
Poils naturels
Scovolino naturale

73-315-13-04	= 210 x 60 x 13 mm
73-315-15-04	= 230 x 65 x 15 mm
73-315-20-04	= 230 x 95 x 20 mm
73-315-25-04	= 230 x 95 x 25 mm
73-315-28-04	= 215 x 95 x 28 mm

73-315-00-04

Satz mit 5 Bürsten
set of 5 brushes
juego de 5 cepillos
jeu de 5 brosses
set a 5 spazzole

73-315-13-04 – 73-315-28-04

Naturborsten mit Wollfasern
Natural bristles with wool fibers
Cerdas naturales con fibras de lana
Poils naturels avec fibres de laine
Scovolino naturale con fibre di lana



73-318-12-04
275 x 75 x 12 mm

73-318-15-04
275 x 90 x 15 mm

73-318-30-04
320 x 150 x 30 mm

73-318-50-04
320 x 130 x 50 mm

54-73

Reinigungsbürsten

Cleaning Brushes

Cepillos de limpieza

Brosses à lavement

Spazzole per pulire

Naturborsten
Natural bristles
Cerdas naturales
Poils naturels
Scovolino naturale



73-324-35-04
360 x 140 x 35 mm



73-326-40-04
440 x 180 x 40 mm

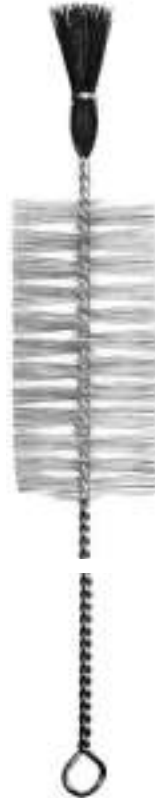

73-327-60-04
510 x 135 x 60 mm



Roßhaarborsten
Horsehair bristles
Cerdas de crin de caballo
Poils en crin
Scovolino in crine di cavallo

73-333-80-04
490 x 150 x 80 mm

Naturborsten
Natural bristles
Cerdas naturales
Poils naturels
Scovolino naturale



73-335-60-04
490 x 160 x 60 mm



73-340-75-04
420 x 130 x 75 mm



73-351-50-04
330 x 130 x 50 mm

Reinigungsbürsten

Cleaning Brushes
Cepillos de limpieza
Brosses à lavement
Spazzole per pulire

Verschiedenes

Miscellaneous
Diversos artículos
Articles divers
Articoli diversi



Naturborsten, konisch
Natural bristles, conical
Cerdas naturales, cónico
Poils naturels, conique
Scovolino naturale, conico



73-356-15-04	73-359-18-04	73-361-15-04	73-365-08-04	73-367-16-04
410 x 190 x 8/20 mm	290 x 110 x 18/33 mm	315 x 85 x 15/25 mm	415 x 70 x 8/15 mm	1000 x 180 x 16 mm

54-73

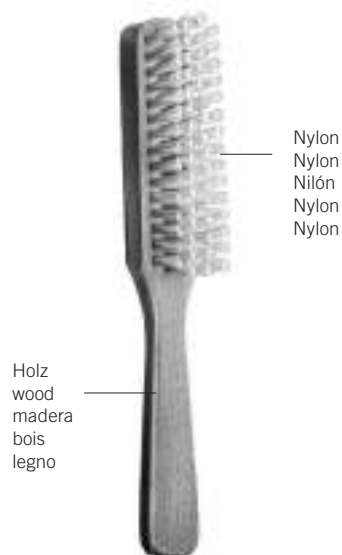

Nylon
Nylon
Nílon
Nylon
Nylon

Holz
wood
madera
bois
legno

73-370-95-04
210 x 95 mm

Abfalleimer, Abfallzangen

Waste Bucket, Waste Forceps

Cobo para desechos, Pinzas para desechos

Seaux pour déchets, Pincés pour déchets

Secchi per rifiuti, Pinze per rifiuti

St
18/8



73-454-15-01

h = 325 mm Ø 305 mm

Inhalt
capacity
capacidad
capacité
capacità
15 l

73-455-15-01



73-454-15-01



1/3

Martin
73-470-58-07
58 cm / 22 7/8"



1/3

Sauerbruch
73-474-55-07
55 cm / 21 5/8"

Laserchirurgie
Laser Surgery
Cirugía láser
Chirurgie laser
Chirurgia laser

76-79

Informationen zu den KLS-Martin-Laser-Systemen entnehmen Sie bitte den separaten Broschüren:

- diodengepumpter Nd:YAG-Laser Limax®
- Diodenlaser diomax®
- CO₂-Laser MCO 25plus und MCO 50plus

Please refer to the separate brochures for information about KLS-Martin laser systems:

- Diode-pumped Nd:YAG Laser Limax®
- Diode laser diomax®
- CO₂ laser MCO 25plus and MCO 50plus

Encontrará información sobre los sistemas láser de KLS-Martin en los folletos específicos:

- Láser Nd:YAG bombeado por diodo Limax®
- Láser de diodo diomax®
- Láser CO₂ MCO 25plus y MCO 50plus

Veuillez vous reporter aux brochures séparées pour obtenir des informations détaillées à propos des systèmes de laser KLS Martin :

- Laser Nd:YAG Limax® pompé par diodes
- Laser à diodes diomax®
- Laser au CO₂ MCO 25plus et MCO 50plus

Per informazioni sui sistemi laser di KLS Martin, consultare le brochure separate:

- Laser Nd:YAG pompato a diodi Limax®
- Laser a diodi diomax®
- Laser CO₂ MCO 25plus e MCO 50plus



MCO 2500 and MCO 50
Mit innovativer Technologie
spezialisiert auf die Zahnmedizin

KLS martin
DENTAL



Das Laser System
für die Zahnmedizin

KLS martin
DENTAL



Der Röntgengepumpte Nd-YAG-Laser Limax
Liefert höchste Ansprüche an
Wirkungsqualität und Patientensicherheit

KLS martin
DENTAL

HF-Chirurgie
HF Surgery
Cirugia AF
Chirurgie HF
Chirurgia AF

80

Spezial-Produkte

Special Products
Productos especiales
Produits spéciaux
Prodotti speciali

Informationen zu den KLS-Martin-Elektrochirurgie-Systemen entnehmen Sie bitte den separaten Katalogen bzw. Broschüren:

- Zubehör für die Elektrochirurgie
- Elektrochirurgiegerät maxium®
- marSeal – das System zur bipolaren Gefäßversiegelung

Please refer to the separate catalogs and brochures for information about KLS-Martin electrosurgery systems:

- Electrosurgery accessories
- Electrosurgery device maxium®
- marSeal – the bipolar vessel sealing system

Encontrará información sobre los sistemas de electrocirugía de KLS-Martin en los catálogos o folletos específicos:

- Accesorios para electrocirugía
- Aparato de electrocirugía maxium®
- marSeal – el sistema para el sellado vascular bipolar

Veillez vous reporter aux catalogues ou brochures séparés pour obtenir des informations détaillées à propos des systèmes d'électrochirurgie KLS Martin:

- Accessoires d'électrochirurgie
- Dispositif d'électrochirurgie maxium®
- marSeal – le système de scellement de vaisseaux bipolaire

Per informazioni sui sistemi di elettrochirurgia di KLS Martin, consultare i cataloghi e/o le brochure separati:

- Accessori per elettrochirurgia
- Apparecchio elettrochirurgico maxium®
- marSeal – il sistema per la sigillatura vascolare bipolare



Deckenversorgungseinheiten
Ceiling-mounting systems
Unidades de alimentación de techo
Unités d'alimentation montées au plafond
Sistemi pensili

85

Spezial-Produkte

Special Products

Productos especiales

Produits spéciaux

Prodotti speciali

Informationen zu den KLS-Martin-Deckenstativ-Systemen entnehmen Sie bitte den separaten Broschüren:

- *Independant®*
- *Independant® ITS*

Please refer to the separate brochures for information about KLS-Martin ceiling mounting systems:

- *Independant®*
- *Independant® ITS*

Veillez vous reporter aux brochures séparées pour obtenir des informations détaillées à propos des statifs de plafond KLS Martin:

- *Independant®*
- *Independant® ITS*

Per informazioni sui sistemi pensili a soffitto di KLS Martin, consultare le brochure separate:

- *Independant®*
- *Independant® ITS*

Encontrará información sobre los sistemas de soportes de techo de KLS-Martin en los folletos específicos:

- *Independant®*
- *Independant® ITS*



OP-Leuchten
Operating Theatre Lights
Lámparas de quirófano
Lampes opératoires
Lampade scialitiche

86-89

Spezial-Produkte

Special Products
Productos especiales
Produits spéciaux
Prodotti speciali

Informationen zu den KLS-Martin-Operations- und Untersuchungsleuchtenentnehmen Sie bitte den separaten Broschüren:

- Operationsleuchten marLED® V10/V16
- Operationsleuchten marLED® E9/E15
- Untersuchungsleuchten marLED® E3

Please refer to the separate brochures for information about KLS-Martin operating lights and examination lights:

- Operating lights marLED® V10/V16
- Operating lights marLED® E9/E15
- Examination lights marLED® E3

Encontrará información sobre las lámparas de quirófano y exploración de KLS-Martin en los folletos específicos:

- Lámparas de quirófano marLED® V10/V16
- Lámparas de quirófano marLED® E9/E15
- Lámparas de exploración marLED® E3

Veillez vous reporter aux brochures séparées pour obtenir des informations détaillées relatives aux éclairages opératoires et d'examen KLS Martin :

- Éclairages opératoires marLED® V10/V16
- Éclairages opératoires marLED® E9/E15
- Éclairages d'examen marLED® E3

Per informazioni sulle lampade scialitiche e le lampade diagnostiche di KLS Martin, consultare le brochure separate:

- Lampade scialitiche marLED® V10/V16
- Lampade scialitiche marLED® E9/E15
- Lampade diagnostiche marLED® E3



Nummern-Index
Index of order numbers
Índice de números de referencia
Index numérique des références de commande
Elenco dei codici



Nummern-Index

Index of order numbers

Índice de números de referencia

Index numérique des références de commande

Elenco dei codici

10

10-002-01-07.....2
10-002-02-07.....2
10-002-03-07.....2
10-002-04-07.....2
10-002-05-07.....2
10-002-06-07.....2
10-002-07-07.....2
10-002-08-07.....2
10-002-09-07.....2
10-002-10-07.....2
10-038-16-07.....3
10-038-20-07.....3
10-038-24-07.....3
10-090-09-07.....4
10-091-09-07.....4
10-092-11-07.....4
10-094-13-07.....4
10-096-00-07.....4
10-100-04-07.....5
10-100-34-07.....5
10-104-41-07.....5
10-104-45-07.....5
10-108-08-07.....6
10-109-09-07.....6
10-112-04-07.....6
10-116-03-07.....6
10-117-03-07.....6
10-118-03-07.....6
10-120-04-07.....6
10-125-01-07.....7
10-125-02-07.....7
10-130-03-07.....7
.....446, 447
10-130-04-07.....7
10-130-05-07.....7
10-133-31-07.....8
10-133-35-07.....8
10-135-01-07.....8
10-137-07-07.....9
10-137-71-07.....9
10-140-03-07.....9
10-142-03-07.....9
10-146-03-07.....9
10-147-03-07.....9
10-148-03-07.....9
10-150-10-04.....10
10-150-11-04.....10
10-150-12-04.....10
10-150-13-04.....10
10-150-15-04.....10
10-150-16-04.....10
10-150-17-04.....10
10-150-18-04.....11
10-150-19-04.....11
10-150-20-04.....11
10-150-21-04.....11
10-150-22-04.....11
10-150-23-04.....11
10-150-24-04.....11
10-150-34-04.....11
10-150-36-04.....11
10-151-12-04.....10
10-151-15-04.....10
10-155-09-04.....10
10-155-10-04.....10
10-155-11-04.....10
10-155-12-04.....10
10-155-13-04.....10
10-155-15-04.....10
10-155-16-04.....10
10-155-17-04.....10
10-155-18-04.....11
10-155-19-04.....11
10-155-20-04.....11
10-155-21-04.....11
10-155-22-04.....11
10-155-23-04.....11
10-155-24-04.....11
10-155-34-04.....11

10-155-36-04.....11
10-156-12-04.....10
10-156-15-04.....10
10-159-00-09.....12
10-160-01-07.....12
10-199-00-01.....10
10-285-18-04.....13
10-285-19-04.....13
10-285-20-04.....13
10-285-21-04.....13
10-285-22-04.....13
10-285-23-04.....13
10-285-24-04.....13
10-295-15-04.....14
10-295-11-04.....14
10-295-12-04.....14
10-295-13-04.....14
10-295-15-04.....14
10-296-12-04.....14
10-296-15-04.....14
10-500-16-07.....15
10-500-19-07.....15
10-560-06-07.....15
10-570-05-07.....15
10-572-05-07.....15
10-800-00-07.....16
10-811-00-07.....16
10-875-00-04.....16
10-877-00-04.....16
10-878-00-07.....17
10-878-01-07.....17
10-880-00-07.....17
10-880-01-07.....17
10-880-02-07.....17
10-882-19-07.....17

11

11-100-11-07.....20
11-100-13-07.....20
11-100-14-07.....20
11-100-15-07.....20
11-100-16-07.....20
11-100-17-07.....20
11-100-18-07.....20
11-100-20-07.....20
11-102-11-07.....22
11-102-13-07.....22
11-102-14-07.....22
11-102-15-07.....22
11-102-16-07.....22
11-102-17-07.....22
11-102-18-07.....22
11-102-20-07.....22
11-104-11-07.....24
11-104-13-07.....24
11-104-14-07.....24
11-104-15-07.....24
11-104-16-07.....24
11-105-11-07.....26
11-105-13-07.....26
11-105-14-07.....26
11-105-15-07.....26
11-105-16-07.....26
11-105-17-07.....26
11-105-18-07.....26
11-105-20-07.....26
11-107-11-07.....28
11-107-13-07.....28
11-107-14-07.....28,
.....446, 447
11-107-15-07.....28
11-107-16-07.....28
11-107-17-07.....28
11-107-18-07.....28
11-107-20-07.....28
11-109-11-07.....30
11-109-13-07.....30
11-109-14-07.....30
11-109-15-07.....30

11-109-16-07.....30
11-120-13-07.....31
11-120-14-07.....31
11-122-13-07.....31
11-122-14-07.....31
11-124-13-07.....31
11-124-14-07.....31
11-125-13-07.....32
11-125-14-07.....32
11-127-13-07.....32
11-127-14-07.....32
11-129-13-07.....32
11-129-14-07.....32
11-136-14-07.....33
11-140-14-07.....33
11-141-14-07.....33
11-142-15-07.....33
11-170-14-07.....34
11-170-15-07.....34
11-170-17-07.....34
11-170-23-07.....34
11-171-14-07.....35
11-171-15-07.....35
11-171-17-07.....35
11-171-23-07.....35
11-174-22-07.....39
11-175-22-07.....39
11-175-30-07.....39
11-180-15-07.....36
11-180-17-07.....36
11-181-15-07.....37
11-181-17-07.....37
11-184-16-07.....38
11-184-19-07.....38
11-184-21-07.....38
11-185-16-07.....38
11-185-19-07.....38
11-185-21-07.....38
11-190-17-07.....39
11-191-17-07.....39
11-200-20-07.....40
11-200-23-07.....40
11-203-20-07.....41
11-203-23-07.....41
11-226-16-07.....42
11-227-16-07.....43
11-230-17-07.....44
11-231-17-07.....44
11-232-24-07.....45
11-233-24-07.....45
11-235-20-07.....46
11-235-23-07.....46
11-248-11-07.....47
11-249-11-07.....48
11-250-14-07.....50
11-252-14-07.....52
11-254-14-07.....52
11-255-14-07.....51,
.....446, 447
11-257-14-07.....52
11-259-14-07.....52
11-264-15-07.....52
11-265-15-07.....52
11-280-18-07.....53
11-280-20-07.....53
11-280-23-07.....53
11-280-25-07.....53
11-280-28-07.....53
11-280-30-07.....53
11-284-18-07.....52
11-284-20-07.....52
11-285-18-07.....54
11-285-20-07.....54
11-285-23-07.....54
11-285-25-07.....54
11-285-28-07.....54
11-285-30-07.....54
11-298-14-07.....56
11-299-14-07.....56
11-300-15-07.....56

11-301-15-07.....56
11-305-00-07.....57
11-306-12-07.....57
11-306-19-07.....57
11-307-19-07.....57
11-308-17-07.....57
11-310-16-07.....60
11-311-16-07.....58
11-313-18-07.....61
11-313-21-07.....61
11-313-24-07.....61
11-314-18-07.....61
11-314-21-07.....61
11-314-24-07.....61
11-315-17-07.....62
11-315-20-07.....62
11-316-17-07.....62
11-316-20-07.....62
11-317-11-07.....63
11-317-14-07.....63
11-319-19-07.....63
11-320-10-07.....64
11-321-10-07.....64
11-324-16-07.....65
11-325-16-07.....65
11-326-14-07.....66
11-327-14-07.....67
11-328-14-07.....68
11-329-14-07.....68
11-330-18-07.....69
11-330-20-07.....69
11-330-23-07.....69
11-331-18-07.....70
11-331-20-07.....70
11-331-23-07.....70
11-335-18-07.....71
11-335-20-07.....71
11-335-23-07.....71
11-339-12-07.....72
11-339-18-07.....72
11-340-14-07.....72
11-341-14-07.....72
11-344-11-07.....72
11-345-11-07.....72
11-350-14-07.....73
11-351-14-07.....74
11-352-14-07.....75
11-353-14-07.....75
11-354-14-07.....75
11-355-14-07.....75
11-357-12-07.....75
11-358-13-07.....75
11-359-12-07.....76
11-359-15-07.....76
11-362-14-07.....77
11-363-14-07.....77
11-364-15-07.....77
11-365-15-07.....78
11-365-18-07.....78
11-367-14-07.....77
11-369-14-07.....77
11-370-01-07.....79
11-370-02-07.....79
11-371-01-07.....79
11-371-02-07.....79
11-371-03-07.....79
11-371-04-07.....79
11-371-05-07.....79
11-371-06-07.....79
11-371-07-07.....79
11-371-08-07.....79
11-374-19-07.....80
11-375-19-07.....80
11-375-24-07.....80
11-379-45-07.....82
11-380-25-07.....81
11-380-45-07.....81
11-380-60-07.....81
11-380-90-07.....81
11-381-00-07.....81

11-381-01-07.....81
11-382-25-07.....82
11-382-45-07.....82
11-382-60-07.....82
11-382-90-07.....82
11-383-01-07.....82
11-384-25-07.....85
11-384-45-07.....85
11-384-60-07.....85
11-384-90-07.....85
11-385-00-07.....85
11-390-45-07.....82
11-390-60-07.....82
11-391-19-07.....83
11-393-19-07.....83
11-394-19-07.....83
11-395-19-07.....83
11-396-19-07.....83
11-397-19-07.....83
11-398-19-07.....83
11-398-25-07.....85
11-398-45-07.....85
11-398-60-07.....85
11-398-90-07.....85
11-399-00-07.....85
11-399-19-07.....83
11-400-25-07.....85
11-400-45-07.....85
11-400-60-07.....85
11-400-90-07.....85
11-401-00-07.....85
11-402-25-07.....85
11-402-45-07.....85
11-402-60-07.....85
11-402-90-07.....85
11-403-00-07.....85
11-404-25-07.....84
11-404-45-07.....84
11-404-60-07.....84
11-404-90-07.....84
11-405-00-07.....84
11-406-25-07.....84
11-406-45-07.....84
11-406-60-07.....84
11-406-90-07.....84
11-407-00-07.....84
11-408-25-09.....85
11-408-45-09.....85
11-408-60-09.....85
11-408-90-09.....85
11-409-00-09.....85
11-410-25-09.....85
11-410-45-09.....85
11-410-60-09.....85
11-410-90-09.....85
11-411-00-09.....85
11-412-25-07.....86
11-412-45-07.....86
11-412-60-07.....86
11-412-90-07.....86
11-413-00-07.....86
11-414-25-07.....86
11-414-45-07.....86
11-414-60-07.....86
11-414-90-07.....86
11-415-00-07.....86
11-416-25-07.....87
11-416-45-07.....87
11-416-60-07.....87
11-416-90-07.....87
11-417-00-07.....87
11-418-25-07.....87
11-418-45-07.....87
11-418-60-07.....87
11-418-90-07.....87
11-419-00-07.....87
11-419-90-07.....88
11-420-11-07.....88
11-421-14-07.....88
11-422-15-07.....88

Nummern-Index

Index of order numbers

Índice de números de referencia

Index numérique des références de commande

Elenco dei codici

11-423-25-07.....	89
11-423-45-07.....	89
11-423-60-07.....	89
11-423-90-07.....	89
11-424-00-07.....	89
11-425-25-07.....	89
11-425-45-07.....	89
11-425-60-07.....	89
11-425-90-07.....	89
11-426-00-07.....	89
11-427-25-07.....	89
11-427-45-07.....	89
11-427-60-07.....	89
11-427-90-07.....	89
11-428-00-07.....	89
11-429-25-07.....	89
11-429-45-07.....	89
11-429-60-07.....	89
11-429-90-07.....	89
11-430-00-07.....	89
11-431-25-07.....	89
11-431-45-07.....	89
11-431-60-07.....	89
11-431-90-07.....	89
11-432-00-07.....	89
11-435-01-07.....	90
11-435-02-07.....	90
11-436-25-07.....	86
11-436-45-07.....	86
11-436-60-07.....	86
11-436-90-07.....	86
11-437-00-07.....	86
11-438-25-07.....	86
11-438-45-07.....	86
11-438-60-07.....	86
11-438-90-07.....	86
11-439-00-07.....	86
11-445-22-07.....	90
11-446-22-07.....	90
11-455-17-07.....	90
11-459-17-07.....	91
11-461-18-07.....	91
11-462-18-07.....	91
11-475-23-07.....	92
11-480-19-07.....	92
11-495-17-07.....	93
11-497-17-07.....	94
11-499-19-07.....	93
11-503-15-07.....	95
11-505-16-07.....	95
11-507-15-07.....	95
11-509-16-07.....	96
11-511-18-07.....	96
11-513-18-07.....	96
11-517-11-07.....	96
11-519-11-07.....	96
11-531-18-07.....	97
11-535-14-07.....	97
11-537-22-07.....	97
11-545-10-07.....	98
11-547-16-07.....	98
11-551-16-07.....	98
11-553-16-07.....	98
11-566-13-07.....	99
11-567-13-07.....	99
11-570-12-07.....	100
11-571-12-07.....	100
11-580-12-07.....	100
11-582-12-07.....	100
11-584-12-07.....	100
11-585-12-07.....	100
11-587-12-07.....	100
11-589-12-07.....	100
11-593-11-07.....	101
11-594-11-07.....	101
11-595-11-07.....	101
11-605-16-07.....	102
11-607-16-07.....	102
11-618-08-07.....	103
11-619-08-07.....	103

11-620-09-07.....	103
11-620-10-07.....	103
11-621-09-07.....	103
11-621-10-07.....	103
11-622-10-07.....	103
11-624-09-07.....	104
11-625-09-07.....	104
11-630-11-07.....	105
11-631-11-07.....	106
11-633-11-07.....	104
11-635-11-07.....	107
11-637-10-07.....	104
11-640-12-07.....	104
11-641-12-07.....	104
11-650-14-07.....	22
11-651-14-07.....	28
11-652-14-07.....	34
11-652-17-07.....	34
11-652-23-07.....	34
11-653-14-07.....	35
11-653-17-07.....	35
11-653-23-07.....	35
11-654-15-07.....	36
11-654-17-07.....	36
11-655-15-07.....	37
11-655-17-07.....	37
11-656-16-07.....	42
11-657-16-07.....	43
11-658-11-07.....	47
11-658-14-07.....	50
11-659-11-07.....	48
11-659-14-07.....	51
11-660-18-07.....	53
11-660-20-07.....	53
11-660-23-07.....	53
11-660-26-07.....	53
11-660-28-07.....	53
11-660-31-07.....	53
11-661-18-07.....	54
11-661-20-07.....	54
11-661-23-07.....	54
11-661-26-07.....	54
11-661-28-07.....	54
11-661-31-07.....	54
11-662-10-07.....	64
11-662-16-07.....	60
11-663-10-07.....	64
11-663-16-07.....	58
11-665-14-07.....	67
11-665-18-07.....	70
11-665-20-07.....	70
11-665-23-07.....	70
11-666-14-07.....	73
11-667-14-07.....	74
11-669-12-07.....	76
11-669-15-07.....	76
11-671-15-07.....	78
11-671-18-07.....	78
11-672-11-07.....	105
11-673-11-07.....	106
11-674-10-07.....	108
11-675-10-07.....	108
11-676-10-07.....	109
11-677-10-07.....	109
11-680-11-07.....	108
11-681-11-07.....	108
11-682-11-07.....	109
11-683-11-07.....	109
11-690-11-07.....	110
11-691-11-07.....	110
11-700-00-07.....	111
11-700-01-07.....	111
11-700-02-07.....	111
11-700-03-07.....	111
11-700-04-07.....	111
11-700-05-07.....	111
11-700-06-07.....	111
11-700-07-07.....	111
11-701-00-07.....	111
11-701-01-07.....	111

11-701-02-07.....	111
11-701-03-07.....	111
11-701-04-07.....	111
11-701-05-07.....	111
11-701-06-07.....	111
11-701-07-07.....	111
11-705-11-07.....	110
11-710-15-07.....	112
11-710-18-07.....	112
11-710-19-07.....	112
11-710-21-07.....	112
11-710-23-07.....	112
11-711-15-07.....	112
11-711-18-07.....	112
11-711-19-07.....	112
11-711-20-07.....	112
11-711-21-07.....	112
11-711-23-07.....	112
11-712-15-07.....	113
11-712-18-07.....	113
11-712-19-07.....	113
11-712-21-07.....	113
11-712-23-07.....	113
11-713-15-07.....	113
11-713-18-07.....	113
11-713-19-07.....	113
11-713-20-07.....	113
11-713-21-07.....	113
11-713-23-07.....	113
11-716-15-09.....	112
11-716-18-09.....	112
11-716-21-09.....	112
11-717-15-09.....	112
11-717-18-09.....	112
11-717-21-09.....	112
11-718-15-09.....	113
11-718-18-09.....	113
11-718-21-09.....	113
11-719-15-09.....	113
11-719-18-09.....	113
11-719-21-09.....	113
11-732-23-07.....	114
11-733-23-07.....	114
11-734-23-07.....	114
11-735-23-07.....	114
11-740-11-07.....	110
11-741-11-07.....	110
11-748-19-07.....	115
11-749-19-07.....	115
11-750-19-07.....	115
11-751-19-07.....	115
11-752-19-07.....	115
11-755-11-07.....	116
11-756-12-07.....	116
11-758-12-07.....	116
11-760-09-07.....	116
11-761-09-07.....	116
11-765-18-07.....	117
11-767-18-07.....	117
11-769-18-07.....	117
11-776-02-07.....	117
11-778-01-07.....	117
11-778-02-07.....	117
11-782-21-07.....	118
11-784-09-07.....	119
11-784-21-07.....	118
11-785-32-07.....	118
11-801-10-07.....	119
11-809-11-07.....	119
11-819-13-07.....	119
11-824-09-07.....	119
11-826-13-07.....	120
11-830-14-07.....	120
11-830-18-07.....	120
11-834-14-07.....	120
11-840-12-07.....	120
11-865-12-07.....	121
11-874-10-07.....	122
11-875-10-07.....	122
11-878-12-07.....	122

11-879-12-07.....	122
11-882-18-07.....	123
11-886-20-07.....	123
11-886-50-07.....	123
11-886-90-07.....	123
11-887-11-07.....	49
11-887-18-07.....	55
11-887-20-07.....	55
11-887-23-07.....	55
11-887-25-07.....	55
11-887-30-07.....	55
11-889-14-07.....	67
11-889-18-07.....	70
11-893-17-07.....	129
11-895-16-07.....	59
11-902-14-07.....	20
11-903-14-07.....	26
11-904-14-07.....	22
11-905-14-07.....	28
11-906-14-07.....	24
11-907-14-07.....	30
11-910-14-07.....	34
11-910-17-07.....	34
11-910-23-07.....	34
11-911-14-07.....	35
11-911-17-07.....	35
11-911-23-07.....	35
11-914-11-07.....	124
11-914-14-07.....	124
11-914-18-07.....	124
11-914-20-07.....	124
11-914-23-07.....	124
11-914-25-07.....	124
11-914-30-07.....	124
11-915-14-07.....	125
11-915-17-07.....	125
11-915-23-07.....	125
11-917-11-07.....	49
11-917-18-07.....	55
11-917-20-07.....	55
11-917-23-07.....	55
11-917-25-07.....	55
11-917-30-07.....	55
11-919-14-07.....	126
11-919-18-07.....	126
11-921-17-07.....	129
11-923-16-07.....	59
11-925-20-07.....	41
11-925-23-07.....	41
11-927-22-07.....	132
11-927-23-07.....	133
11-930-15-07.....	36
11-930-17-07.....	36
11-931-15-07.....	37
11-931-17-07.....	37
11-936-11-07.....	47
11-937-11-07.....	48
11-938-14-07.....	50
11-939-14-07.....	51
11-942-18-07.....	53
11-942-20-07.....	53
11-942-23-07.....	53
11-942-25-07.....	53
11-942-28-07.....	53
11-942-30-07.....	53
11-943-18-07.....	54
11-943-20-07.....	54
11-943-23-07.....	54
11-943-25-07.....	54
11-943-28-07.....	54
11-943-30-07.....	54
11-945-20-07.....	127
11-945-23-07.....	127
11-945-28-07.....	127
11-948-14-07.....	73
11-949-14-07.....	74
11-950-16-07.....	60
11-950-21-07.....	127
11-951-16-07.....	58
11-951-21-07.....	127

11-953-16-07.....	127
11-954-14-07.....	66
11-955-14-07.....	67
11-956-14-07.....	68
11-957-14-07.....	68
11-960-18-07.....	69
11-961-18-07.....	70
11-961-20-07.....	70, 128
11-961-23-07.....	70
11-961-25-07.....	128
11-961-28-07.....	128
11-962-18-07.....	128
11-962-20-07.....	128
11-962-23-07.....	128
11-962-30-07.....	128
11-965-14-07.....	128
11-965-17-07.....	129
11-965-20-07.....	130
11-965-23-07.....	130
11-967-18-07.....	71
11-967-20-07.....	71
11-967-23-07.....	71
11-970-19-07.....	131
11-970-23-07.....	131
11-973-17-07.....	131
11-975-20-07.....	41
11-975-23-07.....	41
11-976-23-07.....	40
11-977-23-07.....	41
11-979-22-07.....	132
11-979-23-07.....	133
11-980-13-07.....	99
11-981-13-07.....	99
11-982-11-07.....	105
11-983-11-07.....	106
11-985-25-07.....	134
11-985-45-07.....	134
11-985-60-07.....	134
11-987-25-07.....	134
11-987-45-07.....	134
11-987-60-07.....	134
11-989-11-07.....	107
11-989-22-07.....	132
11-989-23-07.....	133
11-991-12-07.....	135
11-992-16-07.....	42
11-993-16-07.....	43
11-994-17-07.....	94
11-995-12-07.....	121
11-996-16-07.....	135
11-997-16-07.....	102
11-999-16-07.....	102

12

12-100-10-07.....	138
12-100-11-07.....	138
12-100-13-07.....	138
12-100-14-07.....	138
12-100-16-07.....	138
12-100-18-07.....	138
12-100-20-07.....	138
12-100-23-07.....	138
12-100-25-07.....	138
12-100-30-07.....	138
12-120-11-07.....	138
12-120-13-07.....	138
12-120-14-07.....	138
12-120-16-07.....	138
12-120-18-07.....	138
12-120-20-07.....	138
12-120-23-07.....	138
12-120-25-07.....	138
12-120-30-07.....	138
12-122-13-07.....	139
12-123-15-07.....	139
12-126-13-07.....	139
12-126-14-07.....	139, 446, 447
12-130-15-07.....	139
12-131-17-07.....	139

Nummern-Index

Index of order numbers

Índice de números de referencia

Index numérique des références de commande

Elenco dei codici

12-132-19-07.....	139	12-282-24-09.....	148	12-392-18-07.....	154	12-563-04-07.....	162	12-579-18-09.....	163
12-133-20-07.....	139	12-284-16-09.....	148	12-392-21-07.....	154	12-563-05-07.....	162	12-580-15-09.....	163
12-134-20-07.....	139	12-284-20-09.....	148	12-392-25-07.....	154	12-564-15-07.....	163	12-580-18-09.....	163
12-135-13-07.....	140	12-284-24-09.....	148	12-392-30-07.....	154	12-564-18-07.....	163	12-580-21-09.....	163
12-135-15-07.....	140	12-285-18-07.....	148	12-400-12-07.....	155	12-565-15-07.....	163	12-580-23-09.....	163
12-135-17-07.....	140	12-285-18-09.....	148	12-402-12-07.....	155	12-565-18-07.....	163	12-580-25-09.....	163
12-135-20-07.....	140	12-285-20-07.....	148	12-403-12-07.....	155	12-566-15-07.....	163	12-581-15-09.....	163
12-166-12-07.....	140	12-285-20-09.....	148	12-404-12-07.....	155	12-566-18-07.....	163	12-581-18-09.....	163
12-168-12-07.....	140	12-286-18-07.....	148	12-404-15-07.....	155	12-566-21-07.....	163	12-581-21-09.....	163
12-168-15-07.....	140	12-286-18-09.....	148	12-406-12-07.....	155	12-566-23-07.....	163	12-581-23-09.....	163
12-170-15-07.....	140	12-286-20-07.....	148	12-406-15-07.....	155	12-566-25-07.....	163	12-581-25-09.....	163
12-171-20-07.....	140	12-286-20-09.....	148	12-408-11-07.....	155	12-567-15-07.....	163	12-582-15-09.....	165
12-172-12-07.....	141	12-287-18-07.....	148	12-409-12-07.....	156	12-567-18-07.....	163	12-582-18-09.....	165
12-172-15-07.....	141	12-287-18-09.....	148	12-410-12-07.....	156	12-567-21-07.....	163	12-583-15-09.....	165
12-174-17-07.....	141	12-287-20-07.....	148	12-412-11-07.....	156	12-567-23-07.....	163	12-583-18-09.....	165
12-180-17-07.....	141	12-287-20-09.....	148	12-414-11-07.....	156	12-567-25-07.....	163	12-584-15-09.....	165
12-183-17-07.....	141	12-288-16-09.....	148	12-416-11-07.....	156	12-568-15-07.....	165	12-584-18-09.....	165
12-184-06-07.....	141	12-288-20-09.....	148	12-418-11-07.....	156	12-568-18-07.....	165	12-584-21-09.....	165
12-184-08-07.....	141	12-288-24-09.....	148	12-420-15-07.....	157	12-569-15-07.....	165	12-585-15-09.....	165
12-184-10-07.....	141	12-301-10-07.....	149	12-420-20-07.....	157	12-569-18-07.....	165	12-585-18-09.....	165
12-184-18-07.....	142	12-301-11-07.....	149	12-420-25-07.....	157	12-570-15-07.....	165	12-585-21-09.....	165
12-186-18-07.....	142	12-301-13-07.....	149	12-426-14-07.....	157	12-570-18-07.....	165	12-586-15-09.....	165
12-187-18-07.....	142	12-301-14-07.....	149	12-426-16-07.....	157	12-570-21-07.....	165	12-586-18-09.....	165
12-188-17-07.....	142	446, 447	12-426-20-07.....	157	12-570-23-07.....	165	12-586-21-09.....	165
12-189-17-07.....	142	12-301-16-07.....	149	12-426-25-07.....	157	12-571-15-07.....	165	12-586-23-09.....	165
12-192-18-07.....	142	12-301-18-07.....	149	12-444-18-07.....	157	12-571-18-07.....	165	12-586-25-09.....	165
12-192-21-07.....	142	12-301-20-07.....	149	12-444-26-07.....	157	12-571-21-07.....	165	12-587-15-09.....	165
12-192-25-07.....	142	12-301-23-07.....	149	12-451-18-07.....	158	12-571-23-07.....	165	12-587-18-09.....	165
12-192-30-07.....	142	12-301-25-07.....	149	12-456-23-07.....	158	12-572-00-07.....	164	12-587-21-09.....	165
12-230-17-07.....	143	12-301-30-07.....	149	12-460-18-07.....	158	12-572-01-07.....	164	12-587-23-09.....	165
12-234-17-07.....	143	12-302-11-07.....	149	12-460-23-07.....	158	12-572-02-07.....	164	12-587-25-09.....	165
12-236-15-07.....	143	12-302-13-07.....	149	12-466-23-07.....	159	12-572-03-07.....	164	12-588-15-09.....	165
12-238-15-07.....	143	12-302-14-07.....	149	12-467-23-07.....	159	12-572-04-07.....	164	12-588-18-09.....	165
12-240-16-07.....	143	12-302-16-07.....	149	12-468-18-07.....	159	12-572-05-07.....	164	12-588-21-09.....	165
12-240-18-07.....	143	12-302-17-07.....	149	12-502-10-07.....	160	12-572-06-07.....	164	12-588-23-09.....	165
12-242-16-07.....	143	12-302-18-07.....	149	12-503-10-07.....	160	12-572-07-07.....	164	12-588-25-09.....	165
12-242-18-07.....	143	12-302-20-07.....	149	12-505-10-07.....	160	12-572-08-07.....	164	12-589-15-07.....	165
12-244-12-07.....	144	12-302-25-07.....	149	12-512-10-07.....	160	12-572-09-07.....	164	12-589-18-07.....	165
12-246-12-07.....	144	12-303-14-07.....	150	12-513-10-07.....	160	12-572-15-07.....	164	12-589-21-07.....	165
12-246-15-07.....	144	12-303-16-07.....	150	12-515-10-07.....	160	12-572-20-07.....	164	12-589-23-07.....	165
12-250-12-07.....	144	12-303-20-07.....	150	12-552-01-07.....	161	12-572-25-07.....	164	12-589-25-07.....	165
12-250-15-07.....	144	12-304-14-07.....	150	12-552-02-07.....	161	12-572-30-07.....	164	12-590-15-09.....	165
12-252-12-07.....	144	12-304-16-07.....	150	12-552-03-07.....	161	12-573-00-07.....	164	12-590-18-09.....	165
12-252-15-07.....	144	12-321-13-07.....	150	12-552-04-07.....	161	12-573-01-07.....	164	12-590-21-09.....	165
12-254-17-07.....	145	12-321-14-07.....	150	12-552-05-07.....	161	12-573-02-07.....	164	12-590-23-09.....	165
12-255-18-07.....	145	446, 447	12-552-06-07.....	161	12-573-03-07.....	164	12-590-25-09.....	165
12-256-18-07.....	145	12-321-16-07.....	150	12-552-07-07.....	161	12-573-04-07.....	164	12-591-00-07.....	163
12-258-14-07.....	145	12-321-18-07.....	150	12-552-08-07.....	161	12-573-05-07.....	164	12-591-01-07.....	163
12-258-15-07.....	145	12-321-20-07.....	150	12-552-09-07.....	161	12-573-06-07.....	164	12-591-02-07.....	163
12-258-18-07.....	145	12-321-23-07.....	150	12-552-10-07.....	161	12-573-07-07.....	164	12-591-03-07.....	163
12-258-20-07.....	145	12-321-25-07.....	150	12-552-11-07.....	161	12-573-08-07.....	164	12-591-04-07.....	163
12-258-23-07.....	145	12-321-30-07.....	150	12-552-12-07.....	161	12-573-09-07.....	164	12-591-05-07.....	163
12-258-25-07.....	145	12-323-15-07.....	151	12-553-01-07.....	161	12-573-10-07.....	164	12-592-00-07.....	163
12-260-14-07.....	146	12-326-13-07.....	151	12-553-05-07.....	161	12-573-11-07.....	164	12-592-01-07.....	163
12-260-16-07.....	146	12-326-14-07.....	151	12-553-06-07.....	161	12-573-12-07.....	164	12-592-02-07.....	163
12-260-18-07.....	146	12-331-15-07.....	151	12-553-07-07.....	161	12-573-13-07.....	164	12-592-03-07.....	163
12-260-20-07.....	146	12-332-15-07.....	151	12-553-08-07.....	161	12-573-14-07.....	164	12-592-04-07.....	163
12-260-25-07.....	146	12-366-15-07.....	151	12-553-09-07.....	161	12-573-15-07.....	164	12-592-05-07.....	163
12-266-15-07.....	146	12-366-20-07.....	151	12-560-00-07.....	162	12-573-16-07.....	164	12-600-12-07.....	166
12-266-23-07.....	146	12-367-15-07.....	151	12-560-02-07.....	162	12-573-17-07.....	164	12-601-12-07.....	166
12-270-15-07.....	147	12-367-20-07.....	151	12-560-03-07.....	162	12-573-18-07.....	164	12-604-09-07.....	166
12-270-19-07.....	147	12-367-25-07.....	151	12-560-05-07.....	162	12-573-19-07.....	164	12-604-11-07.....	166
12-270-24-07.....	147	12-368-12-07.....	152	12-560-45-07.....	162	12-574-15-07.....	165	12-604-12-07.....	166
12-272-15-07.....	147	12-368-15-07.....	152	12-560-90-07.....	162	12-574-18-07.....	165	12-605-09-07.....	166
12-272-19-07.....	147	12-370-15-07.....	152	12-561-00-07.....	162	12-574-21-07.....	165	12-605-12-07.....	166
12-272-24-07.....	147	12-371-20-07.....	152	12-561-02-07.....	162	12-574-23-07.....	165	12-616-16-07.....	167
12-273-15-07.....	147	12-371-25-07.....	152	12-561-03-07.....	162	12-574-25-07.....	165	12-618-16-07.....	167
12-273-19-07.....	147	12-372-12-07.....	152	12-561-05-07.....	162	12-575-15-07.....	165	12-619-16-07.....	167
12-273-24-07.....	147	12-372-15-07.....	152	12-561-45-07.....	162	12-575-18-07.....	165	12-624-12-07.....	167
12-274-15-07.....	147	12-373-20-07.....	153	12-561-90-07.....	162	12-575-21-07.....	165	12-626-14-07.....	167
12-274-19-07.....	147	12-374-17-07.....	153	12-562-00-07.....	162	12-575-23-07.....	165	12-630-07-07.....	167
12-274-24-07.....	147	12-380-17-07.....	153	12-562-01-07.....	162	12-575-25-07.....	165	12-630-09-07.....	167
12-276-18-07.....	147	12-383-17-07.....	153	12-562-02-07.....	162	12-576-15-07.....	165	12-630-11-07.....	167
12-278-18-07.....	147	12-384-06-07.....	153	12-562-03-07.....	162	12-576-18-07.....	165	12-640-10-07.....	168
12-279-18-07.....	147	12-384-08-07.....	153	12-562-04-07.....	162	12-576-21-07.....	165	12-641-10-07.....	168
12-280-16-09.....	148	12-384-10-07.....	153	12-562-05-07.....	162	12-576-23-07.....	165	12-655-10-07.....	168
12-280-20-09.....	148	12-386-17-07.....	154	12-563-00-07.....	162	12-576-25-07.....	165	12-656-10-07.....	168
12-280-24-09.....	148	12-386-23-07.....	154	12-563-01-07.....	162	12-578-15-09.....	163	12-657-10-07.....	168
12-282-16-09.....	148	12-387-17-07.....	154	12-563-02-07.....	162	12-578-18-09.....	163	12-659-10-07.....	168
12-282-20-09.....	148	12-388-17-07.....	154	12-563-03-07.....	162	12-579-15-09.....	163	12-661-09-07.....	168

Nummern-Index

Index of order numbers
Índice de números de referencia
Index numérique des références de commande
Elenco dei codici

Index

Index
Indice
Index
Indice



12-664-08-07.....	169
12-666-09-07.....	169
12-674-09-07.....	169
12-676-09-07.....	169
12-680-09-07.....	169
12-695-10-07.....	169
12-720-13-07.....	170
12-721-13-07.....	170
12-725-11-07.....	170
12-740-15-07.....	170
12-741-15-07.....	170
12-774-15-07.....	165
12-774-18-07.....	165
12-774-21-07.....	165
12-774-23-07.....	165
12-774-25-07.....	165
12-776-15-07.....	165
12-776-18-07.....	165
12-776-21-07.....	165
12-776-23-07.....	165
12-776-25-07.....	165
12-786-15-09.....	165
12-786-18-09.....	165
12-786-21-09.....	165
12-786-23-09.....	165
12-786-25-09.....	165
12-787-15-09.....	165
12-787-18-09.....	165
12-787-21-09.....	165
12-787-23-09.....	165
12-787-25-09.....	165

13

13-010-00-07.....	172
13-050-14-07.....	172
13-051-14-07.....	172
13-052-04-07.....	172
13-052-05-07.....	172
13-053-05-07.....	172
13-054-05-07.....	173
13-055-05-07.....	173
13-056-03-07.....	173
13-058-05-07.....	173
13-059-05-07.....	173
13-060-01-07.....	173
13-060-02-07.....	173
13-060-03-07.....	173
13-060-04-07.....	172, 173
13-062-00-07.....	174
13-062-01-07.....	174
13-062-02-07.....	174
13-063-00-07.....	174
13-063-02-07.....	174
13-063-04-07.....	174
13-102-04-07.....	175
13-102-06-07.....	175
13-102-08-07.....	175
13-102-10-07.....	175
13-104-14-07.....	175
13-106-18-07.....	175
13-108-10-07.....	176
13-108-14-07.....	176
13-108-18-07.....	176
13-109-10-07.....	176
13-109-14-07.....	176
13-109-18-07.....	176
13-110-06-07.....	176
13-111-06-07.....	176
13-114-03-07.....	176
13-114-05-07.....	176
13-115-03-07.....	176
13-115-05-07.....	176
13-115-38-07.....	177
13-115-45-07.....	177
13-115-55-07.....	177
13-115-65-07.....	177
13-115-70-07.....	177
13-115-75-07.....	177
13-115-90-07.....	177

13-116-38-07.....	177
13-116-45-07.....	177
13-116-55-07.....	177
13-116-65-07.....	177
13-116-70-07.....	177
13-116-75-07.....	177
13-116-90-07.....	177
13-120-08-07.....	178
13-120-10-07.....	178
13-120-12-07.....	178
13-121-08-07.....	178
13-121-10-07.....	178
13-121-12-07.....	178
13-122-10-07.....	178
13-122-14-07.....	178
13-122-20-07.....	178
13-123-10-07.....	178
13-123-14-07.....	178
13-123-20-07.....	178
13-124-11-07.....	179
13-124-12-07.....	179
13-124-13-07.....	179
13-124-14-07.....	179
13-124-15-07.....	179
13-124-16-07.....	179
13-124-17-07.....	179
13-124-18-07.....	179
13-124-19-07.....	179
13-124-20-07.....	179
13-124-25-07.....	179
13-124-26-07.....	179
13-124-27-07.....	179
13-124-28-07.....	179
13-124-29-07.....	179
13-124-30-07.....	179
13-124-31-07.....	179
13-124-32-07.....	179
13-125-10-07.....	178
13-125-14-07.....	178
13-125-20-07.....	178
13-126-10-09.....	178
13-126-14-09.....	178
13-126-20-09.....	178
13-127-10-09.....	178
13-127-14-09.....	178
13-127-20-09.....	178
13-128-10-09.....	178
13-128-14-09.....	178
13-128-20-09.....	178
13-131-24-07.....	181
13-132-30-09.....	180, 181
13-132-35-09.....	180
13-132-40-09.....	180
13-132-50-09.....	180
13-133-30-09.....	180
13-133-35-09.....	180
13-133-40-09.....	180
13-133-50-09.....	180
13-135-30-09.....	181
13-135-35-09.....	181
13-135-40-09.....	181
13-135-50-09.....	181
13-142-30-09.....	180
13-142-35-09.....	180
13-142-40-09.....	180
13-142-50-09.....	180
13-143-30-09.....	180
13-143-35-09.....	180
13-143-40-09.....	180
13-143-50-09.....	180
13-145-30-09.....	181
13-145-35-09.....	181
13-145-40-09.....	181
13-145-50-09.....	181
13-176-14-07.....	182
13-176-16-07.....	182
13-248-13-07.....	182
13-248-14-07.....	182
13-248-15-07.....	182
13-248-18-07.....	182

13-248-20-07.....	182
13-249-13-07.....	182
13-249-14-07.....	182
13-249-15-07.....	182
13-249-18-07.....	182
13-249-20-07.....	182
13-256-13-07.....	183
13-258-13-07.....	183
13-266-25-07.....	183
13-266-26-07.....	183
13-268-14-07.....	184
13-278-17-07.....	184
13-280-15-07.....	184
13-280-20-07.....	184
13-282-15-07.....	184
13-290-14-07.....	185
13-302-12-07.....	185
13-303-01-07.....	185
13-303-02-07.....	185
13-304-14-07.....	185
13-305-18-07.....	185
13-306-10-07.....	186
13-307-10-07.....	186
13-309-12-07.....	186
13-310-12-07.....	186
13-310-14-07.....	186
13-310-62-09.....	187
13-311-12-07.....	186, 446, 447
13-311-14-07.....	186
13-311-62-09.....	187
13-312-12-07.....	186
13-312-14-07.....	186
13-312-62-09.....	187
13-313-12-07.....	186
13-313-14-07.....	186
13-313-62-09.....	187
13-316-18-07.....	187
13-316-21-07.....	187
13-317-18-07.....	187
13-317-21-07.....	187
13-318-18-07.....	187
13-318-21-07.....	187
13-319-18-07.....	187
13-319-21-07.....	187
13-320-10-07.....	188
13-320-12-07.....	188
13-321-10-07.....	188
13-321-12-07.....	188
13-322-10-07.....	188
13-322-12-07.....	188
13-323-10-07.....	188
13-323-12-07.....	188
13-324-14-07.....	188
13-325-14-07.....	188
13-326-15-07.....	188
13-327-15-07.....	188
13-328-15-07.....	188
13-329-15-07.....	188
13-330-14-07.....	189
13-330-64-09.....	189
13-331-14-07.....	189
13-331-64-09.....	189
13-332-12-07.....	189
13-333-19-07.....	189
13-334-16-07.....	190
13-335-16-07.....	190
13-339-14-07.....	190
13-340-14-07.....	190
13-340-64-09.....	190
13-341-14-07.....	190
13-341-64-09.....	190
13-342-14-07.....	190
13-343-14-07.....	190
13-346-16-07.....	191
13-347-16-07.....	191
13-348-15-07.....	191
13-350-15-07.....	191
13-351-12-07.....	191
13-355-14-07.....	191

13-357-14-07.....	191
13-363-18-07.....	192
13-363-19-07.....	192
13-364-18-07.....	192
13-365-18-07.....	192
13-369-20-07.....	192
13-370-16-07.....	192
13-370-20-07.....	192
13-371-16-07.....	192
13-371-20-07.....	192
13-374-13-07.....	193
13-374-14-07.....	193
13-374-16-07.....	193
13-375-13-07.....	193
13-375-14-07.....	193
13-375-16-07.....	193, 446, 447
13-380-14-07.....	193
13-380-16-07.....	193
13-380-18-07.....	193
13-381-14-07.....	193
13-381-16-07.....	193
13-381-18-07.....	193
13-382-14-07.....	194
13-382-16-07.....	194
13-382-18-07.....	194
13-383-14-07.....	194
13-383-16-07.....	194
13-383-18-07.....	194
13-384-13-07.....	194
13-384-14-07.....	194
13-384-16-07.....	194
13-385-13-07.....	194
13-385-14-07.....	194
13-385-16-07.....	194, 446, 447
13-390-20-07.....	195
13-390-26-07.....	195
13-391-20-07.....	195
13-391-26-07.....	195
13-392-20-07.....	195
13-392-26-07.....	195
13-393-20-07.....	195
13-393-26-07.....	195
13-410-14-07.....	196
13-410-16-07.....	196
13-410-18-07.....	196
13-410-20-07.....	196
13-410-22-07.....	196
13-410-24-07.....	196
13-410-26-07.....	196
13-410-30-07.....	196
13-411-14-07.....	197
13-411-16-07.....	197
13-411-18-07.....	197
13-411-20-07.....	197
13-411-22-07.....	197
13-411-24-07.....	197
13-411-26-07.....	197
13-411-30-07.....	197
13-414-14-07.....	198
13-414-16-07.....	198
13-414-18-07.....	198
13-414-20-07.....	198
13-414-22-07.....	198
13-414-24-07.....	198
13-414-26-07.....	198
13-414-30-07.....	198
13-415-14-07.....	199
13-415-16-07.....	199
13-415-18-07.....	199
13-415-20-07.....	199
13-415-22-07.....	199
13-415-24-07.....	199
13-415-26-07.....	199
13-415-30-07.....	199
13-417-01-07.....	200
13-417-02-07.....	200
13-417-03-07.....	200
13-417-04-07.....	200

13-417-05-07.....	200
13-419-18-07.....	201
13-421-14-07.....	201
13-421-18-07.....	201
13-422-20-07.....	201
13-423-20-07.....	201
13-425-20-07.....	201
13-427-21-07.....	201
13-428-22-07.....	202
13-429-22-07.....	202
13-432-24-07.....	202
13-433-24-07.....	202
13-439-18-07.....	203
13-439-24-07.....	203
13-440-01-07.....	203
13-440-02-07.....	203
13-440-03-07.....	203
13-443-01-07.....	204
13-443-02-07.....	204
13-443-03-07.....	204
13-443-04-07.....	204
13-443-05-07.....	204
13-443-06-07.....	204
13-443-07-07.....	204
13-447-01-07.....	204
13-447-02-07.....	204
13-447-03-07.....	204
13-447-04-07.....	204
13-447-05-07.....	204
13-447-06-07.....	204
13-447-07-07.....	204
13-448-00-07.....	205
13-448-01-07.....	205
13-448-02-07.....	205
13-448-03-07.....	205
13-448-06-07.....	205
13-449-00-07.....	206
13-449-01-07.....	206
13-449-06-07.....	206
13-450-01-07.....	206
13-450-02-07.....	206
13-451-13-07.....	207
13-451-16-07.....	207
13-451-18-07.....	207
13-451-20-07.....	207
13-451-23-07.....	207
13-451-25-07.....	207
13-451-28-07.....	207
13-453-18-07.....	207
13-453-22-07.....	207
13-453-25-07.....	207
13-453-28-07.....	207
13-461-01-07.....	208
13-461-02-07.....	208
13-461-03-07.....	208
13-461-04-07.....	208
13-461-05-07.....	208
13-469-01-07.....	209
13-469-02-07.....	209
13-471-14-07.....	209
13-473-15-07.....	210
13-473-19-07.....	210
13-479-14-07.....	210
13-479-17-07.....	210
13-479-19-07.....	210
13-479-20-07.....	210
13-479-23-07.....	210
13-479-26-07.....	

Nummern-Index

Index of order numbers

Índice de números de referencia

Index numérique des références de commande

Elenco dei codici

13-527-01-07.....	214
13-527-02-07.....	214
13-529-23-07.....	214
13-529-24-07.....	214
13-531-20-07.....	215
13-531-22-07.....	215
13-531-24-07.....	215
13-533-23-07.....	215
13-571-21-07.....	216
13-577-19-07.....	217
13-577-22-07.....	217
13-577-24-07.....	217
13-579-19-07.....	217
13-579-22-07.....	217
13-579-24-07.....	217
13-581-19-07.....	217
13-581-22-07.....	217
13-581-24-07.....	217
13-583-28-07.....	218
13-585-28-07.....	218
13-595-19-07.....	218
13-597-19-07.....	218
13-600-21-07.....	219
13-601-21-07.....	219
13-613-19-07.....	219
13-613-21-07.....	219
13-613-23-07.....	219
13-615-19-07.....	219
13-615-21-07.....	219
13-615-23-07.....	219
13-625-21-07.....	220
13-635-10-07.....	221
13-635-20-07.....	221
13-635-30-07.....	221
13-635-40-07.....	221
13-637-10-07.....	221
13-637-20-07.....	221
13-637-30-07.....	221
13-637-35-07.....	221
13-671-23-07.....	222
13-673-24-07.....	222
13-697-25-07.....	223
13-717-22-07.....	223
13-719-23-07.....	223
13-721-14-07.....	224
13-725-18-07.....	224
13-727-20-07.....	224
13-745-20-07.....	225
13-749-21-07.....	225
13-751-20-07.....	225
13-753-20-07.....	225
13-875-09-07.....	226
13-881-05-07.....	226
13-881-09-07.....	226
13-883-09-07.....	226
13-909-11-07.....	226
13-909-13-07.....	226
13-913-11-07.....	226
13-915-08-07.....	226
13-915-11-07.....	226
13-915-13-07.....	226
13-915-15-07.....	226
13-916-15-07.....	227
13-917-13-07.....	227
13-919-10-07.....	227
13-919-13-07.....	227
13-921-16-07.....	227
13-923-10-07.....	227, 446, 447
13-923-13-07.....	227
13-923-14-07.....	228
13-924-11-07.....	228
13-924-14-07.....	228
13-935-20-07.....	228
13-940-14-07.....	228
13-942-16-07.....	228
13-944-15-07.....	229
13-944-18-07.....	229
13-944-20-07.....	229
13-946-15-07.....	229

13-946-18-07.....	229
13-946-20-07.....	229
13-948-01-04.....	230
13-948-02-07.....	230

14

14-100-22-07.....	232
14-100-27-07.....	232
14-101-22-07.....	232
14-101-27-07.....	232
14-110-13-07.....	233
14-110-16-07.....	233
14-110-18-07.....	233
14-120-17-07.....	233
14-222-20-07.....	234
14-222-22-07.....	234, 446, 447
14-222-27-07.....	234
14-223-20-07.....	234
14-223-22-07.....	234
14-223-27-07.....	234
14-231-40-07.....	234
14-286-25-07.....	235
14-290-25-07.....	235
14-313-26-07.....	235
14-320-24-07.....	236
14-350-25-07.....	236
14-352-18-07.....	236
14-352-20-07.....	236
14-352-25-07.....	236
14-353-25-07.....	236
14-355-18-07.....	236
14-355-20-07.....	236
14-355-25-07.....	236
14-360-25-07.....	237
14-361-25-07.....	237
14-370-18-07.....	237
14-370-25-07.....	237

15

15-006-10-07.....	240
15-066-01-07.....	240
15-066-02-07.....	240
15-068-01-07.....	240
15-068-02-07.....	240
15-068-03-07.....	240
15-068-04-07.....	240
15-068-05-07.....	240
15-070-16-07.....	241
15-072-01-07.....	241
15-072-02-07.....	241
15-074-01-07.....	241
15-074-02-07.....	241
15-074-03-07.....	241
15-074-04-07.....	241
15-075-01-07.....	241
15-075-02-07.....	241
15-075-03-07.....	241
15-075-04-07.....	241
15-078-02-07.....	242
15-078-03-07.....	242
15-078-04-07.....	242
15-079-02-07.....	242
15-079-03-07.....	242
15-079-04-07.....	242
15-086-04-07.....	242
15-087-04-07.....	242
15-088-12-07.....	242
15-091-08-07.....	243
15-091-10-07.....	243
15-091-12-07.....	243
15-091-14-07.....	243
15-091-16-07.....	243
15-091-18-07.....	243
15-093-12-07.....	243
15-093-14-07.....	243
15-093-16-07.....	243
15-093-18-07.....	243
15-095-10-07.....	243
15-095-17-07.....	243
15-095-20-07.....	243

15-095-22-07.....	243
15-099-16-07.....	244
15-100-01-07.....	244
15-100-02-07.....	244, 446, 447
15-100-03-07.....	244
15-100-04-07.....	244
15-101-01-07.....	244
15-101-02-07.....	244
15-101-03-07.....	244
15-101-04-07.....	244
15-151-01-07.....	244
15-151-02-07.....	244
15-151-03-07.....	244
15-151-04-07.....	244
15-151-05-07.....	244
15-151-06-07.....	244
15-171-01-07.....	245
15-161-02-07.....	245
15-164-14-07.....	245
15-166-16-07.....	245
15-167-16-07.....	245
15-170-20-07.....	245
15-171-08-07.....	246
15-171-10-07.....	246
15-171-12-07.....	246
15-171-14-07.....	246
15-171-16-07.....	246
15-171-18-07.....	246
15-172-08-07.....	246
15-172-10-07.....	246
15-172-12-07.....	246
15-172-14-07.....	246
15-172-16-07.....	246
15-172-18-07.....	246
15-174-04-07.....	247
15-174-06-07.....	247
15-174-08-07.....	247
15-174-11-07.....	247
15-174-15-07.....	247
15-174-17-07.....	247
15-174-20-07.....	247
15-174-23-07.....	247
15-176-01-07.....	248
15-176-02-07.....	248
15-191-01-07.....	248
15-191-02-07.....	248
15-192-02-07.....	248
15-195-01-07.....	249
15-195-02-07.....	249
15-195-03-07.....	249
15-200-04-07.....	249
15-201-04-07.....	249
15-210-01-07.....	250
15-210-02-07.....	250
15-210-03-07.....	250
15-210-04-07.....	250
15-210-06-07.....	250
15-211-01-07.....	250
15-211-02-07.....	250
15-211-03-07.....	250
15-211-04-07.....	250
15-211-06-07.....	250
15-220-01-07.....	251
15-220-02-07.....	251
15-220-03-07.....	251
15-220-04-07.....	251
15-220-06-07.....	251
15-221-01-07.....	251
15-221-02-07.....	251
15-221-03-07.....	251
15-221-04-07.....	251
15-221-06-07.....	251
15-222-01-07.....	251
15-222-02-07.....	251
15-222-03-07.....	251
15-222-04-07.....	251
15-222-06-07.....	251
15-230-01-07.....	252
15-231-01-07.....	252

15-232-01-07.....	252
15-240-01-07.....	253
15-240-02-07.....	253
15-240-03-07.....	253
15-240-04-07.....	253
15-240-06-07.....	253
15-240-08-07.....	253
15-241-01-07.....	253
15-241-02-07.....	253
15-241-03-07.....	253
15-241-04-07.....	253
15-241-06-07.....	253
15-241-08-07.....	253
15-242-01-07.....	253
15-242-02-07.....	253
15-242-03-07.....	253
15-242-04-07.....	253
15-242-06-07.....	253
15-242-08-07.....	253
15-245-02-07.....	254
15-245-03-07.....	254
15-245-04-07.....	254
15-245-06-07.....	254
15-246-02-07.....	254
15-246-03-07.....	254
15-246-04-07.....	254
15-246-06-07.....	254
15-251-03-07.....	255
15-253-04-07.....	255
15-261-02-07.....	256
15-266-08-07.....	256
15-267-08-07.....	256
15-281-04-07.....	257
15-283-05-07.....	257
15-287-06-07.....	257
15-289-07-07.....	257
15-291-01-07.....	258
15-291-02-07.....	258
15-291-03-07.....	258
15-291-04-07.....	258
15-291-05-07.....	258
15-293-01-07.....	258
15-293-02-07.....	258
15-293-03-07.....	258
15-293-04-07.....	258
15-293-05-07.....	258
15-295-21-07.....	259
15-297-21-07.....	259
15-299-01-07.....	260
15-301-16-07.....	260
15-301-25-07.....	260
15-307-19-07.....	261
15-313-20-07.....	261
15-315-18-07.....	262
15-315-20-07.....	262
15-315-25-07.....	262
15-315-30-07.....	262
15-315-40-07.....	262
15-317-01-07.....	263
15-317-02-07.....	263
15-317-03-07.....	263
15-317-04-07.....	263
15-317-05-07.....	263
15-317-06-07.....	263
15-317-07-07.....	263
15-317-08-07.....	263
15-317-09-07.....	263
15-319-01-07.....	264
15-319-02-07.....	264
15-319-03-07.....	264
15-319-04-07.....	264
15-319-05-07.....	264
15-319-06-07.....	264
15-319-07-07.....	264
15-319-08-07.....	264
15-321-00-07.....	265
15-321-01-07.....	265
15-321-02-07.....	265
15-321-03-07.....	265
15-321-04-07.....	265

15-321-05-07.....	265
15-325-01-07.....	266
15-325-02-07.....	266
15-351-01-07.....	266
15-351-02-07.....	266
15-351-03-07.....	266
15-361-01-07.....	267
15-361-02-07.....	267
15-361-03-07.....	267
15-381-01-01.....	267
15-381-02-01.....	267
15-391-01-01.....	268
15-391-02-01.....	268
15-391-03-01.....	268
15-395-24-01.....	268
15-397-26-01.....	268
15-401-01-07.....	269
15-401-02-07.....	269
15-401-03-07.....	269
15-405-01-07.....	270
15-405-02-07.....	270
15-405-03-07.....	270
15-405-04-07.....	270
15-405-05-07.....	270
15-405-06-07.....	270
15-441-01-07.....	271
15-441-02-07.....	271
15-441-03-07.....	271
15-452-00-07.....	272
15-452-01-07.....	272
15-452-02-07.....	272
15-452-03-07.....	272
15-452-04-07.....	272
15-452-05-07.....	272
15-461-25-01.....	273
15-469-22-07.....	273
15-471-01-07.....	273
15-471-02-07.....	273
15-471-03-07.....	273
15-501-25-07.....	274
15-505-28-07.....	274
15-507-28-07.....	274
15-537-01-07.....	275
15-537-02-07.....	275
15-537-03-07.....	275
15-545-01-07.....	276
15-545-02-07.....	276
15-551-25-07.....	277
15-558-08-07.....	278
15-558-10-07.....	278
15-558-12-07.....	278
15-558-13-07.....	278
15-558-14-07.....	278
15-558-16-07.....	278
15-558-18-07.....	278
15-559-08-07.....	279
15-559-10-07.....	279
15-559-12-07.....	279
15-559-14-07.....	279
15-559-16-07.....	279
15-559-18-07.....	279
15-561-01-07.....	280
15-561-02-07.....	280
15-561-03-07.....	280
15-563-01-07.....	281
15-563-02-07.....	281
15-563-03-07.....	281
15-563-04-07.....	281
15-563-05-07.....	281
15-563-06-07.....	281
15-564-01-07.....	282
15-564-02-07.....	282
15-564-03-07.....	282
15-564-04-07.....	282
15-564-05-07.....	282
15-564-06-07.....	282
15-577-27-07.....	283
15-579-27-07.....	284
15-581-01-07.....	285
15-581-02-07.....	285

Nummern-Index

Index of order numbers

Índice de números de referencia

Index numérique des références de commande

Elenco dei codici

15-591-01-07.....	286
15-591-02-07.....	286
15-591-03-07.....	286
15-591-04-07.....	286
15-591-05-07.....	286
15-591-06-07.....	286
15-591-07-07.....	287
15-591-08-07.....	287
15-591-09-07.....	287
15-592-04-07.....	288
15-592-07-07.....	288
15-592-08-07.....	288
15-592-10-07.....	288
15-593-01-01.....	289
15-593-02-01.....	289
15-593-03-01.....	289
15-603-01-07.....	290
15-603-02-07.....	290
15-603-03-07.....	290
15-607-26-07.....	291
15-611-01-07.....	291
15-611-02-07.....	291
15-615-01-01.....	292
15-615-02-01.....	292
15-615-03-01.....	292
15-621-28-07.....	293
15-623-20-07.....	293
15-623-30-07.....	293
15-623-40-07.....	293
15-652-01-01.....	294
15-655-00-01.....	294
15-655-01-01.....	294
15-655-02-01.....	294
15-655-03-01.....	294
15-663-00-07.....	295
15-665-00-07.....	295
15-667-06-01.....	295
15-669-13-01.....	295
15-673-01-07.....	296
15-673-02-07.....	296
15-675-00-07.....	296
15-683-00-07.....	297
15-687-00-07.....	297
15-695-00-01.....	297
15-700-05-07.....	298
15-701-05-07.....	298
15-702-07-07.....	298
15-703-07-07.....	298
15-704-07-07.....	298
15-705-07-07.....	298
15-708-04-07.....	299
15-710-06-07.....	299
15-714-07-07.....	300
15-714-10-07.....	300
15-715-07-07.....	300
15-715-10-07.....	300
15-717-10-07.....	299
15-723-10-07.....	300
15-723-20-07.....	300
15-725-14-07.....	301
15-727-14-07.....	301
15-732-20-07.....	301
15-733-21-07.....	302
15-733-22-07.....	302
15-734-20-07.....	303
15-734-21-07.....	303
15-734-24-07.....	303
15-734-26-07.....	303
15-735-20-07.....	303
15-735-24-07.....	303
15-735-26-07.....	303
15-736-24-07.....	303
15-736-26-07.....	304
15-736-27-07.....	304
15-737-26-07.....	304
15-738-25-07.....	305
15-738-26-07.....	304
15-738-27-07.....	305
15-739-25-07.....	305
15-739-26-07.....	304
15-740-13-07.....	306
15-741-13-07.....	306
15-747-10-07.....	306
15-748-10-07.....	306
15-749-10-07.....	306
15-750-13-07.....	307
15-750-14-07.....	307
15-750-16-07.....	307
15-750-17-07.....	307
15-751-13-0730, 446, 447	307
15-751-16-07.....	307
15-752-13-07.....	308
15-753-13-07.....	308
15-754-15-07.....	308
15-755-13-07.....	309
15-756-13-07.....	309
15-757-11-07.....	309
15-759-11-07.....	309
15-761-05-07.....	310
15-761-06-07.....	310
15-761-07-07.....	310
15-762-05-07.....	310
15-762-06-07.....	310
15-762-07-07.....	310
15-765-13-07.....	311
15-767-00-07.....	311
15-767-01-07.....	311
15-767-13-07.....	311
15-768-00-07.....	312
15-768-19-07.....	312
15-768-25-07.....	312
15-768-32-07.....	312
15-769-00-07.....	312
15-770-13-07.....	313
15-770-16-07.....	313
15-770-20-07.....	313
15-770-26-07.....	313
15-771-13-07.....	313
15-771-16-07.....	313
15-771-20-07.....	313
15-771-26-07.....	313
15-772-13-07.....	313
15-772-16-07.....	313
15-772-20-07.....	313
15-772-26-07.....	313
15-773-13-07.....	314
15-774-00-07.....	315
15-774-25-07.....	315
15-774-40-07.....	315
15-774-45-07.....	315
15-774-50-07.....	315
15-774-55-07.....	315
15-774-60-07.....	315
15-775-00-07.....	316
15-775-15-07.....	316
15-775-40-07.....	316
15-775-45-07.....	316
15-775-50-07.....	316
15-775-55-07.....	316
15-775-60-07.....	316
15-776-31-07.....	317
15-776-32-07.....	317
15-777-32-07.....	318
15-777-33-07.....	318
15-778-00-07.....	319
15-778-01-07.....	319
15-778-02-07.....	319
15-778-03-07.....	319
15-778-32-07.....	320
15-790-01-07.....	321
15-790-02-07.....	321
15-792-00-01.....	322
15-792-01-01.....	322
15-792-02-01.....	322
15-793-00-01.....	322
15-794-00-01.....	322
15-794-90-98.....	322
15-798-01-01.....	322
15-801-00-07.....	323
15-802-13-07.....	323

15-802-18-07.....	323
15-804-18-07.....	323
15-820-00-07.....	324, 327,
.....	328, 329
15-822-22-07.....	324
15-823-00-07.....	325
15-823-90-98.....	325
15-824-00-07.....	325
15-824-90-98.....	325
15-826-00-07.....	326,
.....	328, 329
15-826-90-98.....	326
15-828-00-07.....	327
15-828-01-07.....	327
15-830-00-07.....	327
15-830-02-07.....	327
15-830-04-07.....	327
15-839-18-07.....	324, 328
15-839-27-07.....	324, 328
15-839-38-07.....	324,
.....	325, 328
15-839-45-07.....	325, 328
15-839-50-07.....	329
15-839-52-07.....	329
15-839-60-07.....	326, 328
15-839-70-07.....	329
15-839-90-07.....	327, 329
15-839-92-07.....	327, 329
15-839-94-07.....	329
15-840-00-07.....	330
15-844-00-07.....	330
15-844-91-98.....	330
15-846-00-07.....	331
15-850-00-07.....	331
15-850-92-99.....	331
15-852-00-07.....	332
15-854-00-07.....	332
15-856-00-07.....	333
15-856-90-98.....	333
15-856-91-98.....	333
15-858-00-07.....	334
15-859-01-07.....	332, 334
15-859-02-07.....	334, 335
15-859-06-07.....	334
15-860-00-07.....	335
15-860-06-07.....	335
15-860-08-07.....	335
15-868-00-01.....	336
15-868-90-98.....	336
15-868-91-98.....	336
15-882-00-07.....	337
15-882-30-07.....	337
15-884-00-07.....	338
15-884-24-07.....	338, 339
15-889-40-07.....	338, 339
15-889-50-07.....	337,
.....	338, 339
15-889-60-07.....	339
15-889-78-07.....	339
15-889-80-07.....	339
15-889-98-07.....	337, 339
15-889-99-07.....	337, 339
15-906-00-07.....	340
15-906-01-07.....	341
15-906-02-07.....	341
15-906-06-07.....	341
15-906-07-07.....	341
15-906-11-07.....	341
15-906-12-07.....	341
15-906-13-07.....	341
15-906-41-07.....	341
15-906-42-07.....	341
15-906-43-07.....	341
15-906-44-07.....	341
15-906-46-07.....	341
15-906-47-07.....	341
15-906-50-07.....	340
15-910-01-07.....	342
15-910-10-04.....	342
15-910-50-07.....	342, 343

15-917-00-07.....	343
15-917-01-07.....	343
15-917-02-07.....	343
15-917-03-07.....	343
15-917-04-07.....	343
15-917-10-07.....	343
15-917-12-07.....	343
15-917-15-07.....	343
15-963-01-01.....	344
15-963-02-01.....	344
15-963-03-01.....	344
15-971-00-01.....	344
15-971-01-01.....	344
15-971-02-01.....	344
15-975-06-01.....	344
15-975-09-01.....	344
15-975-13-01.....	344
15-975-16-01.....	344
15-975-19-01.....	344
15-975-25-01.....	344

16

16-100-11-01.....	346
16-100-13-01.....	346
16-100-14-01.....	346
16-100-16-01.....	346
16-100-18-01.....	346
16-100-20-01.....	346
16-100-25-01.....	346
16-100-30-01.....	346
16-102-11-01.....	346
16-102-13-01.....	346
16-102-14-01.....	346
16-102-16-01.....	346
16-102-18-01.....	346
16-102-20-01.....	346
16-103-13-01.....	346
16-103-14-01.....	346
16-103-16-01.....	346
16-103-18-01.....	346
16-103-20-01.....	346
16-103-25-01.....	346
16-108-13-01.....	346
16-108-14-01.....	346
16-108-16-01.....	346
16-130-10-08.....	346
16-150-13-07.....	346
16-150-14-07.....	346
16-150-16-07.....	346
16-150-18-07.....	346
16-150-20-07.....	346
16-160-13-01.....	347
16-160-14-01.....	347
16-160-16-01.....	347
16-170-13-01.....	347
16-170-14-01.....	347
16-170-16-01.....	347
16-175-14-01.....	347
16-185-16-01.....	347
16-186-16-07.....	347
16-187-16-07.....	347
16-189-16-07.....	347
16-191-16-07.....	347
16-248-00-01.....	348
16-248-01-07.....	348
16-248-02-07.....	348
16-248-03-07.....	348
16-248-04-07.....	348
16-249-01-07.....	349
16-249-02-07.....	349
16-249-03-07.....	349
16-249-04-07.....	349
16-249-05-07.....	349
16-249-06-07.....	349
16-250-00-01.....	350
16-250-02-04.....	350
16-250-03-07.....	350
16-250-06-07.....	350
16-250-09-07.....	350
16-250-12-07.....	350

Index

Index

Indice

Index

Indice

16-250-15-07.....	350
16-250-80-07.....	350
16-250-90-07.....	350
16-251-02-01.....	351
16-251-03-01.....	351
16-251-04-01.....	351
16-251-06-01.....	351
16-251-07-01.....	351
16-251-08-01.....	351
16-251-10-01.....	351
16-251-12-01.....	351
16-251-14-01.....	351
16-251-30-01.....	351
16-420-10-01.....	352
16-420-14-01.....	352
16-420-16-01.....	352
16-425-14-07.....	352
16-425-15-07.....	352
16-425-16-07.....	352
16-425-18-07.....	352

18

18-306-04-07.....	358
18-348-07-01.....	358
18-350-09-01.....	358
18-352-11-01.....	358
18-510-33-07.....	359
18-510-50-07.....	359
18-511-33-07.....	359
18-511-50-07.....	359
18-512-33-07.....	359
18-512-50-07.....	359
18-513-33-07.....	359
18-513-50-07.....	359
18-514-33-07.....	359
18-514-50-07.....	359
18-516-60-07.....	360
18-521-21-01.....	360
18-522-10-01.....	360
18-523-06-01.....	361
18-523-07-01.....	361
18-523-08-01.....	361
18-523-09-01.....	361
18-523-10-01.....	361
18-523-11-01.....	361
18-523-12-01.....	361
18-523-13-01.....	361
18-524-15-01.....	361
18-524-20-01.....	361
18-524-25-01.....	361
18-524-30-01.....	361
18-524-40-01.....	361
18-524-50-01.....	361
18-525-06-01.....	362
18-525-08-01.....	362
18-525-10-01.....	362
18-525-12-01.....	362
18-526-00-01.....	362
18-526-05-01.....	362
18-526-07-01.....	362
18-526-09-01.....	362
18-526-12-01.....	362
18-527-00-01.....	363
18-527-01-01.....	363
18-527-04-01.....	363
18-527-06-01.....	363
18-527-08-01.....	363
18-528-10-01.....	363
18-528-15-01.....	363
18-528-20-01.....	363
18-529-30-07.....	364
18-529-35-07.....	364
18-529-45-07.....	364
18-531-01-07.....	364
18-533-01-07.....	365
18-535-00-07.....	365
18-540-15-01.....	365
18-540-20-01.....	365

Nummern-Index

Index of order numbers

Índice de números de referencia

Index numérique des références de commande

Elenco dei codici

18-542-21-01.....	366
18-543-27-01.....	366
18-544-16-07.....	366
18-544-20-07.....	366
18-544-28-07.....	366
18-545-00-01.....	367
18-545-01-01.....	367
18-545-02-01.....	367
18-545-10-01.....	367
18-545-11-01.....	367
18-545-12-01.....	367
18-545-13-01.....	367
18-545-15-01.....	367
18-548-19-01.....	368
18-549-19-01.....	368
18-550-22-01.....	368
18-551-22-01.....	368
18-553-09-07.....	369
18-554-09-07.....	369
18-555-09-07.....	369
18-556-06-07.....	369
18-561-35-01.....	370
18-563-31-01.....	370
18-565-30-01.....	370
18-567-33-01.....	370
18-568-28-07.....	371
18-568-30-07.....	371
18-569-21-01.....	372
18-571-21-01.....	372
18-572-05-07.....	372
18-572-10-07.....	372
18-572-15-07.....	372
18-573-05-07.....	372
18-573-10-07.....	372
18-575-05-01.....	373
18-575-06-01.....	373
18-575-07-01.....	373
18-575-08-01.....	373
18-575-24-01.....	373
18-577-01-01.....	373
18-577-02-01.....	373
18-577-03-01.....	373
18-579-23-01.....	373
18-580-08-07.....	374
18-580-10-07.....	374
18-580-12-07.....	374
18-580-14-07.....	374
18-580-16-07.....	374
18-580-18-07.....	374
18-581-08-07.....	374
18-581-10-07.....	374
18-581-12-07.....	374
18-581-14-07.....	374
18-581-16-07.....	374
18-581-18-07.....	374
18-583-08-07.....	375
18-583-10-07.....	375
18-583-12-07.....	375
18-583-14-07.....	375
18-583-16-07.....	375
18-583-18-07.....	375
18-584-08-07.....	375
18-584-10-07.....	375
18-584-12-07.....	375
18-584-14-07.....	375
18-584-16-07.....	375
18-584-18-07.....	375
18-606-00-01.....	376
18-606-01-01.....	376
18-610-12-07.....	376
18-610-15-07.....	376
18-611-20-07.....	376
18-611-30-07.....	376
18-611-37-07.....	376
18-611-50-07.....	376
18-632-12-07.....	377
18-632-14-07.....	377
18-632-16-07.....	377
18-635-10-07.....	377
18-640-10-07.....	377

18-640-15-07.....	377
18-640-20-07.....	377
18-641-20-07.....	377
18-642-20-07.....	364, 377
18-645-15-07.....	378
18-645-20-07.....	378
18-645-25-07.....	378
18-645-30-07.....	378
18-647-15-07.....	378
18-647-20-07.....	378
18-665-20-07.....	378
18-666-20-07.....	378
18-691-15-07.....	378
18-691-20-07.....	378
18-691-25-07.....	378
18-691-30-07.....	378
18-691-40-07.....	378
18-695-03-08.....	379
18-695-04-08.....	379
18-695-05-08.....	379
18-695-06-08.....	379
18-696-06-01.....	376, 379
18-700-10-07.....	379
18-700-15-07.....	379
18-700-20-07.....	379
18-700-25-07.....	379
18-700-30-07.....	379
18-700-35-07.....	379
18-700-40-07.....	379
18-700-50-07.....	379
18-710-14-02.....	379
18-710-18-02.....	379
18-800-00-02.....	380
18-802-00-02.....	380
18-804-00-02.....	380
18-806-00-02.....	380
18-825-01-02.....	380
18-825-02-02.....	380
18-825-03-02.....	380
18-830-00-02.....	380
18-840-00-02.....	380
18-845-00-02.....	380
18-850-03-02.....	380
18-850-04-02.....	380
18-850-05-02.....	380
18-850-06-02.....	380
18-850-07-02.....	380
18-850-08-02.....	380
18-850-09-02.....	380
18-850-10-02.....	380
18-850-11-02.....	380
18-850-12-02.....	380
18-850-13-02.....	380
18-900-01-04.....	381
18-900-02-04.....	381
18-900-05-04.....	381
18-900-10-04.....	381
18-900-20-04.....	381
18-900-50-04.....	381
18-902-01-04.....	381
18-902-02-04.....	381
18-902-05-04.....	381
18-902-10-04.....	381
18-902-20-04.....	381
18-902-50-04.....	381
18-910-01-04.....	381
18-910-02-04.....	381
18-910-05-04.....	381
18-910-10-04.....	381
18-910-20-04.....	381
18-910-50-04.....	381
18-912-01-04.....	381
18-912-02-04.....	381
18-912-05-04.....	381
18-912-10-04.....	381
18-912-20-04.....	381
18-912-50-04.....	381
18-915-02-04.....	382
18-915-05-04.....	382
18-915-10-04.....	382

18-917-02-04.....	382
18-917-05-04.....	382
18-917-10-04.....	382
18-920-01-04.....	382
18-920-02-04.....	382
18-922-01-04.....	382
18-922-02-04.....	382
18-925-01-04.....	383
18-926-01-04.....	383
18-930-05-04.....	384
18-930-10-04.....	384
18-930-15-04.....	384
18-930-20-04.....	384
18-932-05-04.....	384
18-932-10-04.....	384
18-932-15-04.....	384
18-932-20-04.....	384

19

19-301-15-07.....	386
19-301-20-07.....	386
19-303-25-07.....	386
19-350-00-07.....	387
19-351-00-07.....	387
19-352-00-07.....	387
19-353-00-07.....	387
19-353-01-07.....	387
19-353-02-07.....	387
19-353-03-07.....	387
19-353-04-07.....	387
19-360-00-07.....	388
19-361-00-07.....	388
19-363-01-07.....	388
19-363-02-07.....	388
19-363-03-07.....	388
19-363-04-07.....	388
19-380-00-07.....	389
19-383-00-07.....	389
19-383-01-07.....	389
19-383-02-07.....	389
19-383-03-07.....	389
19-383-04-07.....	389
19-384-00-07.....	389
19-387-01-07.....	390, 391
19-387-02-07.....	390
19-387-03-07.....	390
19-387-04-07.....	390, 391
19-390-00-07.....	390
19-391-00-07.....	390
19-392-00-02.....	391
19-395-00-04.....	391
19-395-01-04.....	391
19-398-01-04.....	391
19-398-02-04.....	391
19-398-03-04.....	391
19-398-04-04.....	391
19-500-00-07.....	392
19-505-00-07.....	392
19-510-00-07.....	392
19-515-00-07.....	392
19-520-00-07.....	393
19-520-01-07.....	393
19-520-02-07.....	393
19-520-03-07.....	393
19-520-04-07.....	392, 393
19-540-00-07.....	394
19-545-00-07.....	394
19-550-00-07.....	394
19-555-00-07.....	394
19-560-00-07.....	395
19-560-01-07.....	395
19-560-02-07.....	395
19-560-03-07.....	395
19-560-04-07.....	395
19-565-00-07.....	396
19-570-00-07.....	396
19-575-00-07.....	396
19-575-00-07.....	396
19-585-00-07.....	397

20

20-000-00-07.....	404
20-000-01-07.....	404
20-000-02-07.....	404
20-000-03-07.....	404
20-001-00-07.....	404
20-001-01-07.....	404
20-001-02-07.....	404
20-001-03-07.....	404
20-002-15-07.....	405
20-002-18-07.....	405
20-003-15-07.....	405
20-003-18-07.....	405
20-004-15-07.....	405
20-004-18-07.....	405
20-005-15-07.....	405
20-005-18-07.....	405
20-006-18-07.....	405
20-006-18-09.....	405
20-007-18-07.....	405
20-007-18-09.....	405
20-008-18-07.....	405
20-008-18-09.....	405
20-009-18-07.....	405
20-009-18-09.....	405
20-010-15-07.....	406
20-010-18-07.....	406
20-010-21-07.....	406
20-010-23-07.....	406
20-010-25-07.....	406
20-011-15-07.....	406
20-011-18-07.....	406
20-011-21-07.....	406
20-011-23-07.....	406
20-011-25-07.....	406
20-012-15-07.....	406
20-012-18-07.....	406
20-012-21-07.....	406
20-012-23-07.....	406
20-012-25-07.....	406
20-013-15-07.....	406
20-013-18-07.....	406
20-013-21-07.....	406
20-013-23-07.....	406
20-013-25-07.....	406
20-016-15-09.....	405
20-016-18-09.....	405
20-017-15-09.....	405
20-017-18-09.....	405
20-018-15-09.....	405
20-018-18-09.....	405
20-019-15-09.....	405
20-019-18-09.....	405
20-020-15-09.....	406
20-020-18-09.....	406
20-020-21-09.....	406
20-020-23-09.....	406
20-020-25-09.....	406
20-021-15-09.....	406
20-021-18-09.....	406
20-021-21-09.....	406

20-021-23-09.....	406
20-021-25-09.....	406
20-022-15-09.....	406
20-022-18-09.....	406
20-022-21-09.....	406
20-022-23-09.....	406
20-022-25-09.....	406
20-023-15-09.....	406
20-023-18-09.....	406
20-023-21-09.....	406
20-023-23-09.....	406
20-023-25-09.....	406
20-030-15-07.....	406
20-030-15-09.....	406
20-030-18-07.....	406
20-030-18-09.....	406
20-030-21-07.....	406
20-030-21-09.....	406
20-030-23-07.....	406
20-030-23-09.....	406
20-030-25-07.....	406
20-030-25-09.....	406
20-031-15-07.....	406
20-031-15-09.....	406
20-031-18-07.....	406
20-031-18-09.....	406
20-031-21-07.....	406
20-031-21-09.....	406
20-031-23-07.....	406
20-031-23-09.....	406
20-031-25-07.....	406
20-031-25-09.....	406
20-032-15-07.....	406
20-032-15-09.....	406
20-032-18-07.....	406
20-032-18-09.....	406
20-032-21-07.....	406
20-032-21-09.....	406
20-032-23-07.....	406
20-032-23-09.....	406
20-032-25-07.....	406
20-032-25-09.....	406
20-033-15-07.....	406
20-033-15-09.....	406
20-033-18-07.....	406
20-033-18-09.....	406
20-033-21-07.....	406
20-033-21-09.....	406
20-033-23-07.....	406
20-033-23-09.....	406
20-033-25-07.....	406
20-033-25-09.....	406
20-060-15-07.....	407
20-060-15-09.....	407
20-060-18-07.....	407
20-060-18-09.....	407
20-060-21-07.....	407
20-060-21-09.....	407
20-060-23-07.....	407
20-060-23-09.....	407
20-061-15-07.....	407
20-061-15-09.....	407
20-061-18-07.....	407
20-061-18-09.....	407
20-061-21-07.....	407
20-061-21-09.....	407
20-061-23-07.....	407
20-061-23-09.....	407
20-062-15-07.....	407
20-062-15-09.....	407
20-062-18-07.....	407
20-062-18-09.....	407
20-062-21-07.....	407
20-062-21-09.....	407
20-062-23-07.....	407
20-062-23-09.....	407
20-063-15-07.....	407
20-063-15-09.....	407
20-063-18-07.....	407
20-063-18-09.....	407

Nummern-Index

Index of order numbers

Índice de números de referencia

Index numérique des références de commande

Elenco dei codici

Index

Index

Indice

Index

Indice



20-063-21-07.....	407
20-063-21-09.....	407
20-063-23-07.....	407
20-063-23-09.....	407
20-070-15-07.....	407
20-070-15-09.....	407
20-070-18-07.....	407
20-070-18-09.....	407
20-070-21-07.....	407
20-070-21-09.....	407
20-070-23-07.....	407
20-070-23-09.....	407
20-071-15-07.....	407
20-071-15-09.....	407
20-071-18-07.....	407
20-071-18-09.....	407
20-071-21-07.....	407
20-071-21-09.....	407
20-071-23-07.....	407
20-071-23-09.....	407
20-072-15-07.....	407
20-072-15-09.....	407
20-072-18-07.....	407
20-072-18-09.....	407
20-072-21-07.....	407
20-072-21-09.....	407
20-072-23-07.....	407
20-072-23-09.....	407
20-073-15-07.....	407
20-073-15-09.....	407
20-073-18-07.....	407
20-073-18-09.....	407
20-073-21-07.....	407
20-073-21-09.....	407
20-073-23-07.....	407
20-073-23-09.....	407
20-123-01-04.....	402
20-123-02-04.....	402
20-123-03-04.....	402
20-123-04-04.....	402
20-123-05-04.....	402
20-123-06-04.....	402
20-123-07-04.....	402
20-123-08-04.....	402
20-123-09-04.....	402
20-123-10-04.....	402
20-123-11-04.....	402
20-123-12-04.....	402
20-123-13-04.....	402
20-123-14-04.....	402
20-123-15-04.....	402
20-123-16-04.....	402
20-127-01-04.....	402
20-127-02-04.....	402
20-127-03-04.....	402
20-127-04-04.....	402
20-127-05-04.....	402
20-127-06-04.....	402
20-127-07-04.....	402
20-127-08-04.....	402
20-127-09-04.....	402
20-127-10-04.....	402
20-127-11-04.....	402
20-127-12-04.....	402
20-127-13-04.....	402
20-127-14-04.....	402
20-127-15-04.....	402
20-127-16-04.....	402
20-133-01-04.....	402
20-133-02-04.....	402
20-133-03-04.....	402
20-133-04-04.....	402
20-133-05-04.....	402
20-133-06-04.....	402
20-133-07-04.....	402
20-133-08-04.....	402
20-133-09-04.....	402
20-154-10-04.....	402
20-154-20-04.....	402
20-154-30-04.....	402

20-155-01-04.....	402
20-155-02-04.....	402
20-155-03-04.....	402
20-155-04-04.....	402
20-155-05-04.....	402
20-175-10-04.....	403
20-175-20-04.....	403
20-176-01-04.....	403
20-176-02-04.....	403
20-176-03-04.....	403
20-176-04-04.....	403
20-176-05-04.....	403
20-209-01-04.....	403
20-209-02-04.....	403
20-209-03-04.....	403
20-209-04-04.....	403
20-209-05-04.....	403
20-274-14-07.....	408
20-288-10-07.....	408
20-289-10-07.....	408
20-290-14-07.....	408
20-291-14-07.....	408
20-298-10-07.....	408
20-298-11-07.....	408
20-299-10-07.....	408
20-299-11-07.....	408
20-300-11-07.....	409
20-300-12-09.....	409
20-300-13-07.....	409
20-300-14-07.....	409
20-300-15-09.....	409
20-301-13-07.....	409
20-302-01-07.....	409
20-303-01-07.....	409
20-303-09-07.....	410
20-304-01-07.....	409
20-304-09-07.....	410
20-305-01-07.....	409
20-305-09-07.....	410
20-306-14-07.....	410
20-307-14-07.....	410
20-308-14-07.....	410
20-309-14-07.....	410
20-310-14-07.....	411
20-311-14-07.....	411
20-313-14-07.....	411
20-314-16-07.....	411
20-315-16-07.....	411
20-316-13-07.....	411
20-317-12-07.....	411
20-326-12-07.....	412
20-328-12-07.....	412
20-332-12-07.....	412
20-334-13-07.....	412
20-336-13-07.....	412
20-338-13-07.....	412
20-340-14-07.....	413
20-344-13-07.....	413
20-344-18-07.....	413
20-348-15-07.....	413
20-350-15-07.....	413
20-360-18-07.....	413
20-364-18-07.....	413
20-384-17-07.....	414
20-390-14-07.....	414
20-390-16-07.....	414
20-390-18-07.....	414
20-390-20-07.....	414
20-390-24-07.....	414
20-390-26-07.....	414
20-390-30-07.....	414
20-396-16-07.....	414
20-396-18-07.....	414
20-396-20-07.....	414
20-403-21-07.....	414
20-404-23-07.....	415
20-408-27-07.....	415
20-415-27-07.....	415
20-420-27-07.....	416
20-437-27-07.....	416

20-451-23-07.....	416
20-466-14-07.....	417
20-469-16-07.....	417
20-500-15-07.....	417
20-516-14-07.....	417
20-516-17-07.....	417
20-516-20-07.....	417
20-526-14-07.....	418
20-526-17-07.....	418
20-574-18-07.....	418
20-576-20-07.....	418
20-589-16-07.....	418
20-592-23-07.....	418
20-593-23-07.....	418
20-595-19-07.....	418
20-602-18-07.....	419
20-604-13-07.....	419
20-604-15-07.....	419
20-605-15-07.....	419
20-605-18-07.....	419
20-605-21-07.....	419
20-605-23-07.....	419
20-605-25-07.....	419
20-606-15-07.....	419
20-606-18-07.....	419
20-606-21-07.....	419
20-606-23-07.....	419
20-606-25-07.....	419
20-607-15-07.....	419
20-607-18-07.....	419
20-607-21-07.....	419
20-607-23-07.....	419
20-607-25-07.....	419
20-608-15-07.....	419
20-608-18-07.....	419
20-608-21-07.....	419
20-608-23-07.....	419
20-608-25-07.....	419
20-610-18-07.....	419
20-612-18-07.....	420
20-612-21-07.....	420
20-613-19-07.....	420
20-613-23-07.....	420
20-613-25-07.....	420
20-614-01-07.....	421
20-614-02-07.....	421
20-614-03-07.....	421
20-614-04-07.....	421
20-615-01-07.....	421
20-615-02-07.....	421
20-615-03-07.....	421
20-615-04-07.....	421
20-620-00-07.....	422
20-620-01-07.....	422
20-620-14-07.....	422
20-620-18-07.....	422
20-620-21-07.....	422
20-621-14-07.....	422
20-621-18-07.....	422
20-621-21-07.....	422
20-622-16-07.....	422
20-623-16-07.....	422
20-624-13-07.....	423
20-626-13-07.....	423
20-628-13-07.....	423
20-630-13-07.....	423
20-631-13-07.....	423
20-632-12-07.....	423
20-634-13-07.....	424
20-634-14-07.....	424
20-636-13-07.....	424
20-637-12-07.....	424
20-637-13-07.....	424
20-638-15-07.....	424
.....	446, 447
20-638-20-07.....	424
20-640-18-07.....	425
20-640-20-07.....	425
20-640-26-07.....	425
20-642-16-07.....	425

20-642-18-07.....	425
20-642-20-07.....	425
20-642-24-07.....	425
20-642-26-07.....	425
20-642-30-07.....	425
20-643-20-07.....	426
20-643-24-07.....	426
20-643-26-07.....	426
20-646-18-07.....	426
20-646-20-07.....	426
20-646-23-07.....	426
20-646-26-07.....	426
20-646-31-07.....	426
20-648-27-07.....	426
20-650-13-07.....	427
20-650-15-07.....	427
20-650-18-07.....	427
20-650-20-07.....	427
20-650-23-07.....	427
20-650-26-07.....	427
20-652-15-07.....	427
20-652-17-07.....	427
20-652-20-07.....	427
20-653-27-07.....	427
20-654-13-07.....	428
20-654-15-07.....	428
20-654-18-07.....	428
20-654-20-07.....	428
20-654-23-07.....	428
20-654-26-07.....	428
20-656-27-07.....	428
20-658-14-07.....	429
20-658-18-07.....	429
20-658-20-07.....	429
20-658-23-07.....	429
20-659-20-07.....	429
20-659-24-07.....	429
20-659-26-07.....	429
20-659-28-07.....	429
20-662-20-07.....	429
20-662-24-07.....	429
20-665-22-07.....	429
20-665-23-07.....	430
20-666-00-07.....	430
20-666-02-07.....	430
20-666-03-07.....	430
20-666-04-07.....	430
20-666-05-07.....	430
20-668-00-07.....	430
20-668-01-07.....	430
20-668-02-07.....	430
20-668-03-07.....	430
20-670-00-07.....	431
20-670-01-07.....	431
20-670-02-07.....	431
20-670-03-07.....	431
20-672-14-07.....	431
20-672-17-07.....	431
20-672-18-07.....	431
20-673-12-07.....	432
20-673-15-07.....	432
20-673-16-07.....	432
20-674-14-07.....	432
20-674-17-07.....	432
20-674-20-07.....	432
20-676-14-07.....	433
20-676-17-07.....	433
20-676-20-07.....	433
20-678-17-07.....	433
20-678-20-07.....	433
20-678-23-07.....	433
20-684-18-07.....	433
20-686-20-07.....	434
20-692-18-07.....	434
20-692-20-07.....	434
20-692-23-07.....	434
20-696-20-07.....	434
20-696-23-07.....	434
20-701-15-07.....	435
20-702-15-07.....	435

20-703-15-07.....	435
20-704-15-07.....	435
20-721-19-07.....	435
20-722-19-07.....	435
20-723-19-07.....	435
20-724-19-07.....	435
20-741-23-07.....	435
20-742-23-07.....	435
20-743-23-07.....	435
20-744-23-07.....	435
20-775-25-02.....	436
20-776-01-07.....	436
20-776-02-07.....	436
20-776-03-07.....	436
20-813-32-07.....	436
20-815-21-07.....	436
20-825-20-07.....	437
20-832-19-07.....	437
20-835-13-07.....	437
20-837-13-07.....	437
20-839-24-07.....	438
20-840-24-07.....	438
20-841-20-07.....	438
20-842-20-07.....	438
20-843-20-07.....	438
20-844-20-07.....	438
20-845-21-07.....	438
20-846-21-07.....	438
20-847-21-07.....	438
20-848-21-07.....	438
20-849-27-07.....	438
20-850-27-07.....	438
20-851-27-07.....	439
20-852-27-07.....	439
20-853-28-07.....	439
20-854-28-07.....	439
20-855-20-07.....	439
20-856-20-07.....	439
20-857-20-07.....	439
20-858-20-07.....	439
20-859-20-07.....	439
20-860-20-07.....	438, 439
20-861-30-07.....	440
20-862-30-07.....	440
20-863-30-07.....	440
20-864-30-07.....	440
20-865-25-07.....	441
20-866-28-07.....	441
20-867-25-07.....	441
20-868-18-04.....	442
20-869-27-04.....	442
20-870-01-04.....	442
20-870-24-04.....	442
20-871-19-07.....	442
20-872-19-07.....	442
20-875-03-07.....	442
20-875-05-07.....	442
20-875-07-07.....	442
20-877-22-07.....	443
20-878-22-07.....	443
20-882-23-07.....	443
20-884-21-07.....	443
20-886-23-07.....	443
20-910-18-07.....	444
20-916-12-07.....	444
20-922-12-07.....	444
20-924-12-07.....	444
20-928-12-07.....	444
20-929-12-07.....	444
20-935-14-07.....	444
20-940-01-01.....	445
20-940-02-01.....	445
20-940-04-01.....	445
20-940-05-01.....	445
2	

Nummern-Index

Index of order numbers

Índice de números de referencia

Index numérique des références de commande

Elenco dei codici

21

21-155-23-07	450
21-160-14-07	450
21-165-14-07	450
21-165-18-07	450
21-165-20-07	450
21-195-23-07	451
21-205-20-07	451
21-209-15-01	452
21-209-18-01	452
21-223-24-07	452
21-223-26-07	452
21-275-23-07	453
21-275-26-07	453
21-275-37-07	453
21-277-23-07	453
21-277-26-07	453
21-277-37-07	453
21-291-18-07	454
21-297-24-07	454
21-401-20-07	455
21-420-18-07	455
21-425-18-07	455
21-431-21-07	455
21-520-28-07	456
21-522-23-07	456
21-541-18-07	457
21-545-24-07	457
21-551-00-04	458
21-551-01-04	458
21-553-50-07	458
21-553-65-07	458

23

23-036-00-07	464
23-072-04-07	464
23-074-04-07	464
23-076-01-07	464
23-076-02-07	464
23-076-03-07	464
23-080-03-07	464
23-080-05-07	464
23-100-08-07	465
23-100-10-07	465
23-100-12-07	465
23-100-14-07	465
23-100-16-07	465
23-101-08-07	465
23-101-10-07	465
23-101-12-07	465
23-101-14-07	465
23-101-16-07	465
23-102-08-07	465
23-102-10-07	465
23-102-12-07	465
23-102-14-07	465
23-102-16-07	465
23-105-02-07	466
23-105-03-07	466
23-105-04-07	466
23-105-05-07	466
23-105-06-07	466
23-106-02-07	466
23-106-03-07	466
23-106-04-07	466
23-106-05-07	466
23-106-06-07	466
23-109-02-07	466
23-109-03-07	466
23-109-04-07	466
23-109-05-07	466
23-109-06-07	466
23-110-02-07	466
23-110-03-07	466
23-110-04-07	466
23-110-05-07	466
23-110-06-07	466
23-112-05-04	467
23-112-09-04	467
23-118-04-07	467

23-118-06-07	467
23-118-08-07	467
23-118-10-07	467
23-118-12-07	467
23-118-14-07	467
23-119-04-07	467
23-119-06-07	467
23-119-08-07	467
23-119-10-07	467
23-119-12-07	467
23-119-14-07	467
23-123-10-07	468
23-123-12-07	468
23-123-15-07	468
23-123-20-07	468
23-123-25-07	468
23-124-08-07	468
23-124-10-07	468
23-124-12-07	468
23-124-15-07	468
23-124-20-07	468
23-124-25-07	468
23-125-10-07	469
23-125-12-07	469
23-125-15-07	469
23-125-20-07	469
23-125-25-07	469
23-127-10-07	469
23-127-12-07	469
23-127-15-07	469
23-127-20-07	469
23-127-25-07	469
23-128-50-07	470
23-128-60-07	470
23-128-70-07	470
23-130-00-04	470
23-130-05-07	470
23-130-10-07	470
23-130-16-07	470
23-130-25-07	470
23-130-55-07	470
23-130-60-07	470
23-130-66-07	470
23-130-85-07	470
23-130-90-98	470
23-130-99-07	470
23-131-05-04	471
23-131-10-04	471
23-131-15-04	471
23-131-55-04	471
23-131-60-04	471
23-131-65-04	471
23-132-04-04	472
23-132-06-04	472
23-132-08-04	472
23-132-10-04	472
23-132-12-04	472
23-133-04-04	472
23-133-06-04	472
23-133-08-04	472
23-133-10-04	472
23-133-12-04	472
23-134-05-04	473
23-134-07-04	473
23-134-10-04	473
23-134-15-04	473
23-134-20-04	473
23-134-25-04	473
23-134-30-04	473
23-135-05-04	473
23-135-07-04	473
23-135-10-04	473
23-135-15-04	473
23-135-20-04	473
23-135-25-04	473
23-135-30-04	473
23-136-02-07	474
23-136-03-07	474
23-136-04-07	474
23-136-06-07	474

23-136-08-07	474
23-136-10-07	474
23-136-12-07	474
23-136-15-07	474
23-136-53-07	474
23-136-54-07	474
23-136-56-07	474
23-136-58-07	474
23-136-60-07	474
23-136-62-07	474
23-136-65-07	474
23-138-04-07	475
23-138-06-07	475
23-138-08-07	475
23-138-10-07	475
23-138-13-07	475
23-138-15-07	475
23-138-18-07	475
23-138-20-07	475
23-138-25-07	475
23-138-30-07	475
23-138-38-07	475
23-138-44-07	475
23-138-50-07	475
23-139-04-07	476
23-139-06-07	476
23-139-08-07	476
23-139-10-07	476
23-139-13-07	476
23-139-15-07	476
23-139-18-07	476
23-139-20-07	476
23-139-25-07	476
23-139-30-07	476
23-139-38-07	476
23-139-44-07	476
23-139-50-07	476
23-154-06-07	477
23-154-09-07	477
23-154-13-07	477
23-154-16-07	477
23-154-19-07	477
23-154-25-07	477
23-154-32-07	477
23-155-06-07	477
23-155-09-07	477
23-155-13-07	477
23-155-16-07	477
23-155-19-07	477
23-155-25-07	477
23-155-32-07	477
23-156-09-07	478
23-156-14-07	478
23-156-19-07	478
23-156-25-07	478
23-157-09-07	478
23-157-14-07	478
23-157-19-07	478
23-157-25-07	478
23-160-01-04	479
23-160-02-04	479
23-160-03-04	479
23-160-04-04	479
23-162-03-07	480
23-162-05-07	480
23-162-06-07	480
23-162-08-07	480
23-162-09-07	480
23-170-06-07	480
23-170-13-07	480
23-170-19-07	480
23-170-25-07	480
23-170-32-07	480
23-172-06-07	480
23-172-13-07	480
23-172-19-07	480
23-172-25-07	480
23-172-32-07	480
23-173-06-07	481
23-173-13-07	481

23-173-19-07	481
23-173-25-07	481
23-173-32-07	481
23-176-06-07	481
23-176-13-07	481
23-176-19-07	481
23-176-25-07	481
23-176-32-07	481
23-177-06-07	481
23-177-13-07	481
23-177-19-07	481
23-177-25-07	481
23-177-32-07	481
23-181-30-07	482
23-183-27-07	482
23-197-03-04	483
23-197-05-04	483
23-197-08-04	483
23-198-02-07	483
23-198-03-07	483
23-198-04-07	483
23-198-05-07	483
23-198-06-07	483
23-198-08-07	483
23-198-10-07	483
23-199-12-04	483
23-199-14-04	483
23-199-16-04	483
23-200-01-07	484
23-200-02-07	484
23-200-03-07	484
23-204-01-07	484
23-204-02-07	484
23-204-03-07	484
23-208-20-07	485
23-214-01-07	485
23-214-02-07	485
23-215-19-07	485
23-216-01-07	486
23-218-22-07	486
23-220-17-02	486
23-221-00-04	486
23-224-18-07	486
23-236-01-04	487
23-236-02-04	487
23-238-26-04	487
23-240-29-07	487
23-240-91-98	487
23-242-24-07	488
23-244-24-07	488
23-254-22-07	488
23-255-00-04	488
23-256-18-04	489
23-260-01-07	489
23-260-02-07	489
23-280-01-04	490
23-280-02-04	490
23-280-03-04	490
23-280-04-04	490
23-280-05-04	490
23-280-06-04	490
23-280-10-04	490
23-280-20-04	490
23-280-30-04	490
23-280-40-04	490
23-282-01-04	490
23-282-02-04	490
23-282-03-04	490
23-282-04-04	490
23-282-10-04	490
23-300-10-07	491
23-300-20-07	491
23-300-30-07	491
23-301-01-07	491
23-301-02-07	491
23-301-03-07	491
23-301-04-07	491
23-304-10-07	491
23-304-20-07	491
23-304-30-07	491

23-304-40-07	491
23-305-01-07	491
23-305-02-07	491
23-305-03-07	491
23-305-04-07	491
23-305-05-07	491
23-305-06-07	491
23-306-10-07	491
23-306-20-07	491
23-306-30-07	491
23-306-40-07	491
23-308-10-07	492
23-308-20-07	492
23-308-30-07	492
23-308-40-07	492
23-309-01-07	492
23-309-02-07	492
23-309-03-07	492
23-309-04-07	492
23-309-05-07	492
23-309-06-07	492
23-312-10-07	492
23-312-20-07	492
23-312-30-07	492
23-312-40-07	492
23-313-01-07	492
23-313-02-07	492
23-313-03-07	492
23-313-04-07	492
23-313-05-07	492
23-334-10-07	493
23-334-20-07	493
23-334-30-07	493
23-335-01-07	493
23-335-02-07	493
23-335-03-07	493
23-335-04-07	493
23-335-05-07	493
23-335-06-07	493
23-336-25-07	493
23-337-25-07	493
23-339-25-07	493
23-340-01-07	493
23-340-02-07	493
23-340-03-07	493
23-340-04-07	493
23-340-05-07	493
23-340-06-07	493
23-342-01-07	494
23-342-10-07	494
23-342-20-07	494
23-342-30-07	494
23-344-01-07	494
23-344-02-07	494
23-344-03-07	494
23-344-04-07	494
23-344-05-07	494
23-344-06-07	494
23-345-01-07	494
23-345-02-07	494
23-345-03-07	494
23-345-04-07	494
23-345-05-07	494
23-345-06-07	494
23-347-01-07	495
23-347-02-07	495
23-347-03-07	495
23-347-04-07	495
23-347-05-07	495
23-347-06-07	495
23-348-03-07	495
23-348-04-07	495
23-348-05-07	495
23-350-01-07	495
23-350-02-07	495
23-350-03-07	495
23-351-14-07	496
23-352-13-07	496
23-352-14-07	496
23-352-17-07	496

Nummern-Index

Index of order numbers

Índice de números de referencia

Index numérique des références de commande

Elenco dei codici

23-354-13-07.....	496
23-354-16-07.....	496
23-354-20-07.....	496
23-356-21-07.....	496
23-358-00-07.....	497
23-358-01-07.....	497
23-358-12-07.....	497
23-359-00-07.....	497
23-359-10-07.....	497
23-359-11-07.....	497
23-395-01-07.....	497
23-395-02-07.....	497
23-395-04-07.....	497
23-395-05-07.....	497
23-395-06-07.....	497
23-395-24-07.....	497
23-400-01-07.....	498
23-400-02-07.....	498
23-400-03-07.....	498
23-400-04-07.....	498
23-400-10-07.....	498
23-400-11-07.....	498
23-400-12-07.....	498
23-400-20-07.....	499
23-400-21-07.....	499
23-400-25-07.....	499
23-400-26-07.....	499
23-400-30-07.....	499
23-401-18-07.....	500
23-402-19-07.....	500
23-404-18-07.....	500
23-405-17-07.....	500
23-406-16-07.....	500
23-407-15-07.....	500
23-408-18-07.....	501
23-409-14-07.....	501
23-411-05-07.....	501
23-411-06-07.....	501
23-411-07-07.....	501
23-412-20-07.....	501
23-413-20-07.....	501
23-414-19-07.....	501
23-416-11-07.....	502
23-417-11-07.....	502
23-418-15-07.....	502
23-419-15-07.....	502
23-421-01-07.....	502
23-421-02-07.....	502
23-421-03-07.....	502
23-421-04-07.....	502
23-423-01-07.....	503
23-423-02-07.....	503
23-423-04-07.....	503
23-423-05-07.....	503
23-423-06-07.....	503
23-423-07-07.....	503
23-425-06-07.....	503
23-425-10-07.....	503
23-425-13-07.....	503
23-425-19-07.....	503
23-425-25-07.....	503
23-426-06-07.....	503
23-426-10-07.....	503
23-426-13-07.....	503
23-426-19-07.....	503
23-426-25-07.....	503
23-427-21-07.....	504
23-428-06-04.....	504
23-429-14-04.....	504
23-432-14-04.....	504
23-432-18-04.....	504
23-433-03-04.....	504
23-433-13-04.....	505
23-433-18-04.....	505
23-434-13-07.....	505
23-436-04-07.....	505
23-436-05-07.....	505
23-436-07-07.....	505
23-436-16-07.....	505
23-437-20-04.....	506

23-438-03-07.....	506
23-438-06-07.....	506
23-439-06-07.....	506
23-439-08-07.....	506
23-441-17-07.....	507
23-443-17-07.....	507
23-445-17-07.....	507
23-447-17-07.....	507
23-448-21-07.....	508
23-450-01-07.....	508
23-450-02-07.....	508
23-450-03-07.....	508
23-450-04-07.....	508
23-450-05-07.....	508
23-461-05-07.....	508
23-461-10-07.....	508
23-461-15-07.....	508
23-461-20-07.....	508
23-461-25-07.....	508
23-479-28-07.....	509
23-481-24-07.....	509
23-482-22-07.....	509
23-484-17-07.....	510
23-485-17-07.....	510
23-486-17-07.....	510
23-487-17-07.....	510
23-490-01-07.....	510
23-490-02-07.....	510
23-490-03-07.....	510
23-490-04-07.....	510
23-490-05-07.....	510
23-491-01-07.....	511
23-491-02-07.....	511
23-491-03-07.....	511
23-491-04-07.....	511
23-492-01-07.....	511
23-493-01-07.....	511
23-495-20-07.....	512
23-497-20-07.....	512
23-498-23-07.....	512
23-499-01-07.....	512
23-499-02-07.....	512
23-499-03-07.....	512
23-499-04-07.....	512
23-510-17-07.....	513
23-513-16-07.....	513
23-516-18-07.....	513
23-517-20-07.....	513
23-525-21-07.....	513
23-526-18-07.....	513
23-527-19-07.....	513
23-537-06-07.....	514
23-539-06-07.....	514
23-539-08-07.....	514
23-539-15-07.....	514
23-539-16-07.....	514
23-541-08-07.....	515
23-541-18-07.....	515
23-541-43-07.....	515
23-541-70-07.....	516
23-543-43-07.....	516
23-545-22-07.....	516
23-545-35-07.....	517
23-547-24-07.....	517
23-549-22-07.....	517
23-559-24-01.....	518
23-561-24-01.....	518
23-563-26-07.....	519
23-565-26-07.....	519
23-567-17-07.....	519
23-571-16-07.....	519
23-573-16-07.....	519
23-630-17-07.....	520
23-631-17-07.....	520
23-633-17-07.....	520
23-643-22-07.....	520
23-645-22-07.....	520
23-650-22-07.....	520
23-651-22-07.....	520
23-652-01-07.....	521

23-652-02-07.....	521
23-652-03-07.....	521
23-652-04-07.....	521
23-652-05-07.....	521
23-654-40-07.....	521
23-654-45-07.....	521
23-654-55-07.....	521
23-656-00-07.....	521
23-656-01-07.....	521
23-660-31-07.....	522
23-662-29-07.....	522
23-664-23-02.....	522
23-674-16-07.....	523
23-676-15-07.....	523
23-676-19-07.....	523
23-676-24-07.....	523
23-678-00-07.....	523
23-678-01-07.....	523
23-679-11-07.....	523
23-680-13-07.....	524
23-681-20-07.....	524
23-682-15-07.....	524
23-683-15-07.....	524
23-704-14-07.....	525
23-710-20-07.....	525
23-711-20-07.....	525
23-713-20-07.....	525
23-715-19-07.....	525
23-716-19-07.....	526
23-717-12-07.....	526
23-718-17-07.....	526
23-720-14-07.....	526
23-721-09-07.....	526
23-721-14-07.....	526
23-722-21-07.....	527
23-724-21-07.....	527
23-726-18-07.....	527
23-727-20-07.....	528
23-729-16-07.....	528
23-729-24-07.....	528
23-730-17-07.....	529
23-730-21-07.....	529
23-731-19-07.....	529
23-732-23-07.....	530
23-732-26-07.....	530
23-734-26-07.....	530
23-746-23-07.....	531
23-746-25-07.....	531
23-746-28-07.....	531
23-747-23-07.....	531
23-747-25-07.....	531
23-747-28-07.....	531
23-749-15-07.....	532
23-749-19-07.....	532
23-749-24-07.....	532
23-749-26-07.....	532
23-749-28-07.....	532
23-749-90-98.....	532
23-750-33-07.....	533
23-752-33-07.....	533
23-755-01-07.....	534
23-755-02-07.....	534
23-755-03-07.....	534
23-757-01-07.....	535
23-762-30-07.....	535
23-777-01-07.....	536
23-777-02-07.....	536
23-799-12-07.....	536
23-801-14-07.....	536
23-803-14-07.....	536
23-805-14-07.....	536
23-807-17-07.....	536
23-815-16-07.....	537
23-816-16-07.....	537
23-819-18-07.....	537
23-826-18-07.....	537
23-828-18-07.....	537
23-829-18-07.....	537
23-832-19-07.....	537
23-833-19-07.....	537

23-835-15-07.....	538
23-835-30-07.....	538
23-836-00-07.....	538
23-836-30-07.....	538
23-836-90-07.....	538
23-837-15-07.....	538
23-839-15-07.....	538
23-846-17-07.....	539
23-847-17-07.....	539
23-853-15-07.....	539
23-864-15-07.....	539
23-865-15-07.....	539
23-876-15-07.....	539
23-877-15-07.....	539
23-879-18-07.....	539
23-881-18-07.....	539
23-883-17-07.....	540
23-885-20-07.....	540
23-887-18-07.....	540
23-893-23-07.....	540
23-895-22-07.....	540
23-897-23-07.....	540
23-899-02-07.....	541
23-899-03-07.....	541
23-899-04-07.....	541
23-901-23-07.....	541
23-905-24-07.....	542
23-907-24-07.....	542
23-909-24-07.....	542
23-910-22-07.....	543
23-911-22-07.....	543
23-912-23-07.....	543
23-912-27-07.....	543
23-913-23-07.....	543
23-913-27-07.....	543
23-916-30-07.....	544
23-918-30-07.....	544
23-930-19-07.....	545
23-934-14-07.....	545
23-934-17-07.....	545
23-934-19-07.....	545
23-934-22-07.....	545
23-935-14-07.....	545
23-935-17-07.....	545
23-935-19-07.....	545
23-935-22-07.....	545
23-939-17-07.....	546
23-941-15-07.....	546
23-944-15-07.....	546
23-946-15-07.....	546
23-947-16-07.....	546
23-950-18-07.....	547
23-951-18-07.....	547
23-952-27-07.....	547
23-954-27-07.....	548
23-955-23-07.....	548
23-955-27-07.....	548
23-957-27-07.....	549
23-959-24-07.....	549

24

24-100-23-07.....	554
24-101-22-07.....	554
24-107-22-07.....	554
24-126-34-07.....	555
24-131-26-07.....	555
24-137-27-07.....	555
24-147-28-07.....	556
24-149-28-07.....	556
24-151-24-07.....	556
24-156-01-07.....	557
24-156-02-07.....	557
24-156-03-07.....	557
24-156-04-07.....	557
24-156-05-07.....	557
24-156-06-07.....	557
24-156-24-07.....	557
24-156-36-07.....	557
24-157-24-07.....	557
24-157-36-07.....	557

Index

Index

Indice

Index

Indice



24-159-01-09.....	558
24-159-02-09.....	558
24-159-03-09.....	558
24-160-01-04.....	558
24-160-02-04.....	558
24-160-03-04.....	559
24-160-04-04.....	559
24-161-01-04.....	559
24-161-02-04.....	559
24-163-01-04.....	560
24-163-02-04.....	560
24-163-03-04.....	560
24-165-01-04.....	560
24-165-02-04.....	560
24-165-03-04.....	560
24-166-01-04.....	561
24-166-02-04.....	561
24-166-03-04.....	561
24-167-01-04.....	561
24-168-90-07.....	562
24-169-01-04.....	562
24-170-00-07.....	563
24-171-00-07.....	563
24-174-02-07.....	563
24-177-75-07.....	564
24-178-01-07.....	564
24-178-02-07.....	564
24-178-03-07.....	564
24-179-00-07.....	565
24-179-01-07.....	565
24-179-02-07.....	565
24-179-03-07.....	565
24-179-04-07.....	565
24-180-00-07.....	566
24-180-01-07.....	566
24-180-02-07.....	566
24-180-03-07.....	566
24-180-04-07.....	566
24-180-05-07.....	566
24-180-06-07.....	566
24-181-00-07.....	567
24-181-01-07.....	567
24-181-02-07.....	567
24-181-03-07.....	567
24-181-04-07.....	567
24-182-00-07.....	568
24-182-01-07.....	568
24-182-02-07.....	568, 569
24-182-03-07.....	568, 569
24-182-04-07.....	568, 569
24-182-05-07.....	569
24-182-06-07.....	569
24-183-00-07.....	570
24-183-01-07.....	570
24-183-02-07.....	570
24-183-03-07.....	570, 571
24-183-04-07.....	570, 571
24-183-05-07	

Nummern-Index

Index of order numbers

Índice de números de referencia

Index numérique des références de commande

Elenco dei codici

24-188-01-07.....579	24-336-30-07.....596	24-398-11-07.....612	24-435-23-07.....635	24-461-54-09.....649
24-188-02-07.....579	24-336-45-07.....596	24-399-06-07.....612	24-435-27-07.....635	24-462-01-09.....650
24-188-03-07.....579	24-336-90-07.....596	24-399-07-07.....612	24-435-31-07.....635	24-462-02-09.....650
24-188-04-07.....579	24-338-00-07.....596	24-399-09-07.....612	24-436-18-07.....636	24-462-03-09.....650
24-189-00-07.....580	24-338-15-07.....596	24-399-11-07.....612	24-436-19-07.....636	24-462-04-09.....650
24-189-01-07.....580, 581	24-338-30-07.....596	24-400-21-07.....613	24-436-23-07.....636	24-462-05-09.....650
24-189-02-07.....580, 581	24-338-45-07.....596	24-400-22-07.....613	24-436-27-07.....636	24-462-20-09.....651
24-189-03-07.....581	24-338-90-07.....596	24-401-21-07.....613	24-437-18-07.....637	24-462-21-09.....651
24-189-04-07.....581	24-340-18-07.....597	24-401-22-07.....613	24-437-20-07.....637	24-462-22-09.....651
24-189-05-07.....581	24-341-17-07.....597	24-403-21-07.....614	24-437-21-07.....637	24-462-23-09.....651
24-189-09-07.....582	24-341-18-07.....597	24-403-22-07.....614	24-437-25-07.....637	24-462-40-09.....652
24-189-10-04.....582	24-341-19-07.....597	24-405-22-07.....615	24-437-29-07.....637	24-462-41-09.....652
24-189-10-07.....582	24-342-14-07.....598	24-407-22-07.....615	24-438-12-07.....638	24-462-42-09.....652
24-189-11-04.....582	24-342-16-07.....598	24-408-19-07.....615	24-438-14-07.....638	24-462-43-09.....653
24-189-11-07.....582	24-342-18-07.....598	24-408-23-07.....615	24-438-16-07.....638	24-462-44-09.....653
24-189-12-04.....582	24-343-18-07.....599	24-409-16-07.....616	24-438-18-07.....638	24-462-45-09.....653
24-189-12-07.....582	24-343-19-07.....599	24-411-19-07.....616	24-438-20-07.....638	24-462-46-09.....653
24-189-20-04.....583	24-344-16-07.....600	24-411-20-07.....616	24-439-12-07.....638	24-462-47-09.....653
24-189-20-07.....583	24-344-17-07.....600	24-413-18-07.....617	24-439-14-07.....638	24-462-48-09.....654
24-189-21-04.....583	24-344-18-07.....600	24-413-19-07.....617	24-439-16-07.....638	24-462-60-09.....655
24-189-21-07.....583	24-344-20-07.....600	24-413-20-07.....617	24-439-18-07.....638	24-462-61-09.....655
24-189-22-04.....583	24-344-24-07.....601	24-414-15-07.....618	24-439-20-07.....638	24-462-62-09.....655
24-189-22-07.....583	24-344-27-07.....601	24-414-18-07.....618	24-440-17-07.....639	24-462-63-09.....655
24-189-23-04.....583	24-344-30-07.....602	24-415-15-07.....618	24-441-16-07.....639	24-464-16-07.....656
24-189-23-07.....583	24-345-18-07.....603	24-415-18-07.....618	24-443-15-07.....639	24-464-20-07.....656
24-218-19-07.....584	24-347-18-07.....603	24-416-20-07.....618	24-445-15-07.....639	24-466-00-07.....657
24-220-14-07.....584	24-349-17-07.....603	24-417-26-07.....619	24-447-17-07.....640	24-466-01-07.....657
24-224-16-07.....584	24-349-18-07.....604	24-417-27-07.....619	24-449-17-07.....640	24-466-02-07.....657
24-226-16-07.....584	24-349-20-07.....604	24-417-31-07.....619	24-451-17-07.....640	24-466-03-07.....657
24-230-02-07.....585	24-350-00-07.....605	24-417-33-07.....619	24-451-21-07.....640	24-466-04-07.....657
24-230-03-07.....585	24-350-01-07.....605	24-418-28-07.....620	24-451-26-07.....640	24-466-05-07.....657
24-230-04-07.....585	24-350-02-07.....605	24-419-30-07.....620	24-453-16-07.....641	24-466-06-07.....657
24-230-05-07.....585	24-350-03-07.....605	24-420-25-07.....621	24-454-16-07.....641	24-467-21-07.....658
24-231-30-01.....586	24-350-04-07.....605	24-420-27-07.....621	24-454-17-07.....641	24-468-17-07.....658
24-231-32-01.....586	24-350-05-07.....605	24-421-24-07.....622	24-455-17-07.....641	24-469-18-07.....659
24-233-30-07.....586	24-350-07-07.....605	24-422-24-07.....622	24-456-16-07.....642	24-469-20-07.....659
24-241-22-07.....587	24-350-08-07.....605	24-423-25-07.....623	24-456-17-07.....642	24-469-26-07.....659
24-245-22-07.....587	24-350-09-07.....605	24-423-26-07.....623	24-456-18-07.....642	24-470-17-07.....660
24-247-22-07.....587	24-352-22-07.....606	24-424-01-07.....624	24-457-17-07.....642	24-471-16-07.....660
24-265-24-07.....588	24-352-25-07.....606	24-424-02-07.....624	24-457-19-07.....642	24-472-15-07.....660
24-267-24-07.....588	24-352-31-07.....606	24-424-03-07.....625	24-457-21-07.....642	24-472-16-07.....660
24-280-10-09.....589	24-353-25-07.....607	24-424-04-07.....625	24-458-10-07.....643	24-472-17-07.....660
24-280-25-09.....589	24-354-19-07.....608	24-425-00-07.....625	24-458-11-07.....643	24-473-17-07.....661
24-280-45-09.....589	24-354-26-07.....609	24-425-01-07.....626	24-458-12-07.....643	24-474-17-07.....661
24-280-60-09.....589	24-354-27-07.....608	24-425-02-07.....626	24-459-12-07.....643	24-475-26-07.....662
24-281-10-09.....589	24-354-32-07.....609	24-425-03-07.....626	24-459-13-07.....643	24-475-27-07.....662
24-281-25-09.....589	24-354-34-07.....608	24-425-07-07.....627	24-460-01-09.....644	24-475-28-07.....662
24-281-45-09.....589	24-384-16-07.....610	24-425-08-07.....627	24-460-02-09.....644	24-476-17-07.....663
24-281-60-09.....589	24-384-20-07.....610	24-425-09-07.....627	24-460-03-09.....644	24-477-16-07.....663
24-282-10-09.....589	24-384-24-07.....610	24-425-15-07.....627	24-460-04-09.....644	24-477-17-07.....663
24-282-25-09.....589	24-384-30-07.....610	24-425-20-07.....628	24-460-05-09.....644	24-478-16-07.....664
24-282-45-09.....589	24-386-16-07.....610	24-425-24-07.....628	24-460-06-09.....645	24-478-17-07.....664
24-282-60-09.....589	24-386-20-07.....610	24-425-25-07.....628	24-460-07-09.....645	24-478-18-07.....664
24-286-20-07.....590	24-386-24-07.....610	24-425-26-07.....628	24-460-08-09.....644	24-478-21-07.....664
24-287-20-07.....590	24-388-16-07.....610	24-425-27-07.....628	24-460-09-09.....645	24-479-17-07.....664
24-288-07-09.....591	24-388-20-07.....610	24-426-01-07.....629	24-460-10-09.....645	24-480-23-07.....664
24-288-08-09.....591	24-388-24-07.....610	24-426-02-07.....629	24-460-11-09.....645	24-480-25-07.....664
24-288-09-09.....591	24-388-30-07.....610	24-426-03-07.....629	24-461-01-09.....646	24-482-00-07.....665
24-288-10-09.....591	24-389-16-07.....611	24-426-04-07.....629	24-461-02-09.....646	24-484-00-07.....665
24-289-07-09.....591	24-389-20-07.....611	24-427-23-07.....630	24-461-03-09.....646	24-492-05-01.....667
24-289-08-09.....591	24-389-24-07.....611	24-427-25-07.....630	24-461-04-09.....646	24-492-10-01.....667
24-289-09-09.....591	24-389-30-07.....611	24-429-25-07.....630	24-461-05-09.....646	24-492-15-01.....667
24-289-10-09.....591	24-390-16-07.....610	24-430-00-07.....631	24-461-06-09.....646	24-492-20-01.....667
24-291-07-07.....592	24-390-20-07.....610	24-430-01-07.....631	24-461-07-09.....646	24-492-25-01.....667
24-291-09-07.....592	24-390-24-07.....610	24-430-21-07.....632	24-461-08-09.....646	24-492-30-01.....667
24-291-10-07.....592	24-390-30-07.....610	24-430-22-07.....632	24-461-09-09.....646	24-492-35-01.....667
24-293-06-07.....592	24-392-07-07.....591	24-431-17-07.....632	24-461-10-09.....646	24-492-40-01.....667
24-295-07-07.....592	24-392-08-07.....591	24-432-18-07.....633	24-461-11-09.....646	24-492-45-01.....667
24-297-09-07.....593	24-392-10-07.....591	24-432-20-07.....633	24-461-30-09.....647	24-492-50-01.....667
24-297-11-07.....593	24-392-12-07.....591	24-432-23-07.....633	24-461-31-09.....647	24-492-70-01.....667
24-299-01-07.....593	24-393-07-07.....591	24-432-25-07.....633	24-461-32-09.....647	24-492-90-01.....667
24-299-02-07.....593	24-393-08-07.....591	24-433-23-07.....634	24-461-33-09.....647	24-493-05-01.....667
24-300-16-07.....594	24-393-10-07.....591	24-433-24-07.....634	24-461-34-09.....648	24-493-10-01.....667
24-301-16-07.....594	24-393-12-07.....591	24-433-25-07.....634	24-461-35-09.....648	24-493-15-01.....667
24-302-15-07.....594	24-394-01-07.....611	24-433-26-07.....634	24-461-36-09.....648	24-493-20-01.....667
24-303-15-07.....594	24-394-02-07.....611	24-434-21-07.....635	24-461-37-09.....648	24-493-25-01.....667
24-317-23-07.....595	24-395-23-07.....612	24-434-23-07.....635	24-461-50-09.....649	24-493-30-01.....667
24-319-21-07.....595	24-398-06-07.....612	24-434-27-07.....635	24-461-51-09.....649	24-493-35-01.....667
24-336-00-07.....596	24-398-07-07.....612	24-434-31-07.....635	24-461-52-09.....649	24-493-40-01.....667
24-336-15-07.....596	24-398-09-07.....612	24-435-21-07.....635	24-461-53-09.....649	24-493-45-01.....667

Nummern-Index

Index of order numbers

Índice de números de referencia

Index numérique des références de commande

Elenco dei codici

Index

Index

Indice

Index

Indice



24-493-50-01.....	667
24-502-00-01.....	668
24-502-01-01.....	668
24-502-05-01.....	668
24-502-06-01.....	668
24-502-11-01.....	668
24-502-55-01.....	668
24-502-56-01.....	668
24-502-57-01.....	668
24-502-58-01.....	668
24-502-60-01.....	668
24-502-62-01.....	668
24-502-65-01.....	668
24-502-70-01.....	668
24-502-99-07.....	668
24-506-05-01.....	666
24-506-10-01.....	666
24-506-15-01.....	666
24-506-20-01.....	666
24-506-25-01.....	666
24-506-30-01.....	666
24-507-05-01.....	666
24-507-10-01.....	666
24-507-15-01.....	666
24-507-20-01.....	666
24-507-25-01.....	666
24-507-30-01.....	666
24-509-05-04.....	667
24-509-10-04.....	667
24-509-15-04.....	667
24-509-20-04.....	667
24-509-25-04.....	667
24-509-30-04.....	667
24-509-35-04.....	667
24-509-40-04.....	667
24-509-45-04.....	667
24-509-50-04.....	667
24-510-05-04.....	667
24-510-10-04.....	667
24-510-15-04.....	667
24-510-20-04.....	667
24-510-25-04.....	667
24-510-30-04.....	667
24-510-35-04.....	667
24-510-40-04.....	667
24-510-45-04.....	667
24-510-50-04.....	667
24-510-70-04.....	667
24-510-90-04.....	667
24-515-05-04.....	666
24-515-10-04.....	666
24-515-15-04.....	666
24-515-20-04.....	666
24-515-25-04.....	666
24-515-30-04.....	666
24-516-05-04.....	666
24-516-10-04.....	666
24-516-15-04.....	666
24-516-20-04.....	666
24-516-25-04.....	666
24-516-30-04.....	666
24-526-25-07.....	669
24-526-32-07.....	669
24-526-40-07.....	669
24-526-52-07.....	669
24-535-18-07.....	670
24-535-21-07.....	670
24-537-14-07.....	670
24-537-24-07.....	670
24-539-01-07.....	670
24-539-02-07.....	670
24-539-03-07.....	670
24-539-04-07.....	670
24-541-20-07.....	671
24-543-20-07.....	671
24-550-15-07.....	671
24-550-20-07.....	671
24-550-25-07.....	671
24-550-30-07.....	671
24-556-33-07.....	671

24-558-33-07.....	671
24-559-15-07.....	672
24-561-16-07.....	672
24-563-16-07.....	672
24-573-01-07.....	673
24-573-02-07.....	673
24-573-03-07.....	673
24-573-04-07.....	673
24-573-05-07.....	673
24-573-06-07.....	673
24-573-07-07.....	673
24-573-08-07.....	673
24-573-09-07.....	673
24-573-10-07.....	673
24-573-11-07.....	673
24-573-12-07.....	673
24-573-13-07.....	673
24-573-14-07.....	673
24-573-15-07.....	673
24-580-01-07.....	674
24-580-01-09.....	674
24-580-02-07.....	674
24-580-02-09.....	674
24-580-03-07.....	674
24-580-03-09.....	674
24-580-04-07.....	674
24-580-04-09.....	674
24-580-05-07.....	674
24-580-05-09.....	674
24-581-01-09.....	675
24-581-02-09.....	675
24-581-03-09.....	675
24-581-04-09.....	675
24-581-05-09.....	675
24-588-16-07.....	676
24-589-16-07.....	676
24-590-16-07.....	676
24-591-15-07.....	676
24-592-16-07.....	676
24-593-00-07.....	677
24-593-01-07.....	677
24-593-02-07.....	677
24-593-03-07.....	677
24-595-01-07.....	677
24-595-02-07.....	677
24-595-03-07.....	677
24-597-12-07.....	677
24-600-30-07.....	682
24-600-40-07.....	682
24-600-50-07.....	682
24-600-60-07.....	682
24-600-70-07.....	682
24-602-01-01.....	682
24-618-33-07.....	682
24-641-01-07.....	683
24-641-02-07.....	683
24-641-04-07.....	683
24-641-05-07.....	683
24-643-01-07.....	683
24-643-10-07.....	683
24-654-20-07.....	684
24-658-21-07.....	684
24-659-22-07.....	684
24-661-14-07.....	685
24-663-19-07.....	685
24-674-00-07.....	685
24-675-00-07.....	685
24-676-00-07.....	685
24-678-01-07.....	686
24-678-02-07.....	686
24-680-25-07.....	686
24-681-24-07.....	686
24-682-18-07.....	686
24-683-24-07.....	687
24-684-19-07.....	687
24-685-21-07.....	687
24-686-21-07.....	688
24-687-21-07.....	688
24-688-22-07.....	688
24-690-01-07.....	689

24-690-02-07.....	689
24-690-03-07.....	689
24-690-04-07.....	689
24-690-05-07.....	689
24-691-24-07.....	688
24-702-01-07.....	690
24-702-02-07.....	690
24-702-03-07.....	690,
.....	691, 692
24-702-04-07.....	690, 691
24-702-05-07.....	690, 691
24-702-06-07.....	691
24-702-07-07.....	691, 692
24-702-08-07.....	690,
.....	691, 692
24-702-11-07.....	692
24-702-12-07.....	692
24-702-13-07.....	692, 693
24-702-14-07.....	692, 693
24-702-15-07.....	691,
.....	692, 693
24-702-16-07.....	692, 693
24-720-08-01.....	694
24-720-11-01.....	694
24-720-14-01.....	694
24-720-17-01.....	694
24-721-14-01.....	694
24-721-17-01.....	694
24-721-20-01.....	694
24-738-26-07.....	695
24-740-26-07.....	695
24-742-19-07.....	695
24-742-28-07.....	695
24-744-19-07.....	695
24-744-28-07.....	695
24-748-17-07.....	695
24-748-21-07.....	695
24-823-20-07.....	696
24-824-20-07.....	696
24-825-16-07.....	696
24-827-18-07.....	696
24-830-19-07.....	697
24-831-19-07.....	697
24-835-13-07.....	697
24-835-18-07.....	697
24-850-01-07.....	698
24-850-02-07.....	698
24-850-03-07.....	698
24-850-04-07.....	698
24-850-05-07.....	698
24-850-10-07.....	698
24-850-11-07.....	698
24-850-15-07.....	698
24-850-20-07.....	699
24-850-21-07.....	699
24-850-22-07.....	699
24-850-23-07.....	699
24-850-24-07.....	699
24-850-25-07.....	699
24-850-26-07.....	699
24-850-28-07.....	699
24-850-30-07.....	699
24-850-31-07.....	699
24-850-32-07.....	699
24-850-33-07.....	699
24-850-40-07.....	700
24-850-41-07.....	700
24-850-42-07.....	700
24-850-50-07.....	700
24-850-60-07.....	700
24-851-01-07.....	701
24-851-02-07.....	701
24-851-10-07.....	701
24-851-11-07.....	701
24-851-12-07.....	701
24-851-13-07.....	701
24-852-01-07.....	702
24-852-02-07.....	702
24-852-10-07.....	702
24-852-11-07.....	702

24-852-12-07.....	702
24-852-20-07.....	702
24-852-21-07.....	702
24-852-22-07.....	702
24-852-23-07.....	702
24-852-24-07.....	702
24-852-25-07.....	702
24-852-26-07.....	702
24-852-30-07.....	702
24-852-31-07.....	702
24-852-40-07.....	702
24-852-41-07.....	702
24-852-50-07.....	702
24-852-51-07.....	702
24-852-60-07.....	703
24-852-61-07.....	703
24-852-70-07.....	702
24-852-71-07.....	702
24-852-72-07.....	702
24-852-73-07.....	702
24-852-74-07.....	702
24-852-75-07.....	702
24-852-76-07.....	702
24-852-77-07.....	702
24-852-78-07.....	702
24-853-01-07.....	704
24-853-02-07.....	704
24-853-03-07.....	704
24-854-01-07.....	704
24-854-02-07.....	704
24-854-03-07.....	704
24-854-04-07.....	704
24-854-05-07.....	704
24-854-06-07.....	704
24-854-07-07.....	704
24-854-08-07.....	704
24-854-09-07.....	704
24-854-10-07.....	704
24-854-11-07.....	704
24-854-12-07.....	704
24-856-01-07.....	705
24-856-02-07.....	705
24-856-03-07.....	705
24-856-04-07.....	705
24-856-05-07.....	705
24-856-06-07.....	705
24-856-10-07.....	705
24-858-01-07.....	705
24-858-10-07.....	705
24-858-11-07.....	705
24-858-12-07.....	705
24-858-13-07.....	705
24-858-20-07.....	705
24-858-21-07.....	705
24-858-30-07.....	705
24-860-01-07.....	706
24-860-02-07.....	706
24-860-03-07.....	706
24-860-04-07.....	706
24-862-01-07.....	706
24-862-02-07.....	706
24-862-03-07.....	706
24-862-04-07.....	706
24-862-05-07.....	706
24-862-06-07.....	706
24-862-07-07.....	706
24-862-10-07.....	706
24-862-11-07.....	706
24-862-20-07.....	706
24-863-01-07.....	707
24-863-10-07.....	707
24-863-11-07.....	707
24-863-12-07.....	707
24-863-13-07.....	707
24-864-01-07.....	708
24-864-02-07.....	708
24-865-01-07.....	708
24-865-10-07.....	708
24-865-11-07.....	708
24-866-01-07.....	708

24-866-02-07.....	708
24-940-01-07.....	709
24-940-02-07.....	709
24-940-03-07.....	709
24-940-04-07.....	709
24-942-05-07.....	709
24-942-07-07.....	709
24-942-09-07.....	709
24-942-11-07.....	709
24-973-16-07.....	710
24-974-17-07.....	710
24-975-17-07.....	710
24-977-27-07.....	711
24-978-01-07.....	712
24-978-01-14.....	712
24-978-02-07.....	712
24-978-02-14.....	712
24-978-03-07.....	712
24-978-03-14.....	712
24-978-04-07.....	712
24-978-04-14.....	712
24-978-05-07.....	712
24-978-05-14.....	712
24-978-06-07.....	712
24-978-06-14.....	712
24-978-07-07.....	712
24-978-07-14.....	712
24-978-08-07.....	712
24-978-08-14.....	712
24-978-09-07.....	712
24-978-09-14.....	712
24-978-10-07.....	712
24-978-10-14.....	712
24-978-11-07.....	712
24-978-11-14.....	712
24-978-12-07.....	712
24-978-12-14.....	712
24-978-13-07.....	712
24-978-13-14.....	712
24-978-14-07.....	712
24-978-14-14.....	712
24-978-15-07.....	712
24-978-15-14.....	712
24-978-16-07.....	712
24-978-16-14.....	712
24-978-17-07.....	712
24-978-17-14.....	712
24-978-18-07.....	712
24-978-18-14.....	712
24-978-19-07.....	712
24-978-19-14.....	712
24-978-20-07.....	712
24-978-20-14.....	712
24-978-21-07.....	712
24-978-21-14.....	712
24-978-22-07.....	712
24-978-22-14.....	712
24-978-23-07.....	712
24-978-23-14.....	71

Nummern-Index

Index of order numbers

Índice de números de referencia

Index numérique des références de commande

Elenco dei codici

24-981-17-07.....	724
24-981-17-14.....	724
24-981-18-07.....	724
24-981-18-14.....	724
24-981-19-07.....	724
24-981-19-14.....	724
24-981-20-07.....	724
24-981-20-14.....	724
24-981-25-07.....	725
24-981-25-14.....	725
24-981-26-07.....	725
24-981-26-14.....	725
24-981-27-07.....	725
24-981-27-14.....	725
24-981-28-07.....	725
24-981-28-14.....	725
24-981-29-07.....	725
24-981-29-14.....	725
24-981-30-07.....	725
24-981-30-14.....	725
24-981-31-07.....	725
24-981-31-14.....	725
24-981-32-07.....	725
24-981-32-14.....	725
24-981-33-07.....	725
24-981-33-14.....	725
24-981-34-07.....	725
24-981-34-14.....	725
24-981-35-07.....	725
24-981-35-14.....	725
24-981-36-07.....	725
24-981-36-14.....	725
24-981-37-07.....	725
24-981-37-14.....	725
24-981-38-07.....	725
24-981-38-14.....	725
24-981-39-07.....	725
24-981-39-14.....	725
24-981-40-07.....	725
24-981-40-14.....	725
24-981-45-07.....	726
24-981-45-14.....	726
24-981-46-07.....	726
24-981-46-14.....	726
24-981-47-07.....	726
24-981-47-14.....	726
24-981-48-07.....	726
24-981-48-14.....	726
24-981-49-07.....	726
24-981-49-14.....	726
24-981-50-07.....	726
24-981-50-14.....	726
24-981-51-07.....	726
24-981-51-14.....	726
24-981-52-07.....	726
24-981-52-14.....	726
24-981-53-07.....	726
24-981-53-14.....	726
24-981-54-07.....	726
24-981-54-14.....	726
24-981-55-07.....	726
24-981-55-14.....	726
24-981-56-07.....	726
24-981-56-14.....	726
24-981-57-07.....	726
24-981-57-14.....	726
24-981-58-07.....	726
24-981-58-14.....	726
24-981-59-07.....	726
24-981-59-14.....	726
24-981-60-07.....	726
24-981-60-14.....	726
24-981-61-07.....	727
24-981-61-14.....	727
24-981-62-07.....	727
24-981-62-14.....	727
24-981-63-07.....	727
24-981-63-14.....	727
24-981-64-07.....	727
24-981-64-14.....	727

24-981-65-07.....	727
24-981-65-14.....	727
24-981-66-07.....	727
24-981-66-14.....	727
24-981-67-07.....	727
24-981-67-14.....	727
24-981-68-07.....	727
24-981-68-14.....	727
24-981-71-07.....	728
24-981-71-14.....	728
24-981-72-07.....	728
24-981-72-14.....	728
24-981-73-07.....	728
24-981-73-14.....	728
24-981-74-07.....	728
24-981-74-14.....	728
24-981-75-07.....	728
24-981-75-14.....	728
24-981-76-07.....	728
24-981-76-14.....	728
24-981-77-07.....	728
24-981-77-14.....	728
24-981-78-07.....	728
24-981-78-14.....	728
24-981-80-07.....	729
24-981-80-14.....	729
24-981-81-07.....	729
24-981-81-14.....	729
24-981-82-07.....	729
24-981-82-14.....	729
24-981-83-07.....	729
24-981-83-14.....	729
24-981-84-07.....	730
24-981-84-14.....	730
24-981-85-07.....	730
24-981-85-14.....	730
24-981-86-07.....	730
24-981-86-14.....	730
24-981-87-07.....	730
24-981-87-14.....	730
24-981-91-07.....	730
24-981-91-14.....	730
24-981-92-07.....	730
24-981-92-14.....	730
24-981-93-07.....	730
24-981-93-14.....	730
24-981-94-07.....	730
24-981-94-14.....	730
24-981-95-07.....	730
24-981-95-14.....	730
24-981-96-07.....	730
24-981-96-14.....	730
24-982-10-07.....	731
24-982-10-14.....	731
24-982-11-07.....	731
24-982-11-14.....	731
24-982-12-07.....	731
24-982-12-14.....	731
24-982-13-07.....	731
24-982-13-14.....	731
24-996-25-07.....	732
24-996-27-07.....	732
24-996-50-07.....	732
24-996-51-07.....	732
24-998-08-07.....	733
24-998-09-07.....	733
24-998-10-07.....	733
24-999-07-07.....	733
24-999-09-07.....	733
24-999-11-07.....	733
27	
27-113-14-07.....	740
27-115-14-07.....	740
27-125-16-07.....	741
27-127-16-07.....	741
27-143-13-07.....	741
27-145-11-07.....	741
27-151-17-07.....	741
27-155-17-07.....	741

27-411-15-07.....	742
27-413-15-07.....	742
27-449-15-07.....	742
27-449-20-07.....	742
28	
28-135-14-07.....	744
28-188-01-07.....	744
28-188-02-07.....	744
28-188-03-07.....	744
28-188-04-07.....	744
28-196-01-07.....	744
28-196-02-07.....	744
28-196-03-07.....	744
28-196-04-07.....	744
28-196-05-07.....	744
28-196-06-07.....	744
28-203-15-07.....	745
28-207-18-07.....	745
28-209-18-07.....	745
28-215-03-07.....	745
28-215-04-07.....	745
28-240-02-07.....	745
28-240-03-07.....	745
28-240-04-07.....	745
28-240-05-07.....	745
28-240-06-07.....	745
28-240-07-07.....	745
28-240-08-07.....	745
28-261-14-07.....	746
28-263-14-07.....	746
28-271-10-07.....	746
28-275-14-07.....	746
28-279-10-07.....	746
28-294-14-07.....	746
28-296-11-07.....	746
28-300-15-07.....	747
28-501-14-07.....	747
28-503-15-07.....	747
28-503-18-07.....	747
28-505-18-07.....	747
28-521-18-07.....	748
28-525-18-07.....	748
28-529-23-07.....	748
30	
30-130-12-07.....	750
30-132-15-07.....	750
30-134-15-07.....	750
30-134-19-07.....	750
30-134-25-07.....	750
30-136-16-07.....	750
30-136-20-07.....	750
30-136-25-07.....	750
30-136-30-07.....	750
30-138-15-07.....	751
30-142-15-07.....	751
30-148-15-07.....	751
30-148-19-07.....	751
30-150-20-07.....	751
30-154-20-07.....	751
30-170-20-07.....	751
30-186-16-07.....	752
30-190-16-07.....	752
30-190-20-07.....	752
30-192-16-07.....	753
30-192-18-07.....	753
30-192-20-07.....	753
30-192-24-07.....	753
30-196-16-07.....	753
30-196-20-07.....	753
30-206-20-07.....	753
30-210-18-07.....	754
30-210-20-07.....	754
30-212-20-07.....	754
30-212-23-07.....	754
30-274-21-07.....	754
30-274-23-07.....	754
30-275-21-07.....	754
30-275-23-07.....	754

30-276-18-07.....	755
30-277-18-07.....	755
30-286-21-07.....	756
30-286-23-07.....	756
30-287-21-07.....	756
30-287-23-07.....	756
30-288-25-07.....	756
30-289-25-07.....	756
30-304-22-07.....	757
30-304-25-07.....	757
30-304-28-07.....	757
30-305-22-07.....	758
30-305-25-07.....	758
30-305-28-07.....	758
30-398-16-07.....	758
30-415-15-07.....	759
30-419-21-07.....	759
30-425-29-07.....	759
30-433-35-07.....	759
30-496-05-07.....	760
30-496-07-07.....	760
30-496-10-07.....	760
30-497-26-07.....	760
30-498-08-07.....	761
30-498-23-07.....	761
30-519-16-07.....	761
30-520-07-07.....	762
30-520-10-07.....	762
30-522-00-07.....	762
30-524-15-07.....	762
30-534-30-07.....	763
30-535-30-07.....	764
30-540-18-07.....	765
30-540-20-07.....	765
30-540-23-07.....	765
30-550-13-07.....	766
30-550-16-07.....	766
30-550-18-07.....	766
30-550-21-07.....	766
30-550-23-07.....	766
30-551-13-07.....	766
30-551-16-07.....	766
30-551-18-07.....	766
30-551-21-07.....	766
30-551-23-07.....	766
30-554-25-07.....	767
30-555-25-07.....	767
30-560-22-07.....	768
30-560-25-07.....	768
30-560-28-07.....	768
30-561-22-07.....	769
30-561-25-07.....	769
30-561-28-07.....	769
30-570-33-07.....	770
30-571-33-07.....	770
30-580-24-07.....	770
30-581-26-07.....	771
30-581-28-07.....	771
30-583-23-07.....	772
30-585-24-07.....	772
30-587-30-07.....	773
30-610-21-07.....	774
30-613-15-01.....	774
30-615-15-01.....	774
30-624-20-07.....	774
30-641-15-07.....	774
30-647-00-07.....	775
30-647-50-07.....	775
30-647-51-01.....	775
30-647-92-98.....	775
30-647-93-98.....	775
30-647-94-98.....	775
30-647-95-98.....	775
30-649-01-07.....	776
30-649-02-07.....	776
30-723-10-04.....	776
30-723-26-07.....	776
30-723-27-07.....	776
30-724-19-07.....	777
30-741-38-07.....	777

Index

Index

Indice

Index

Indice



31

31-101-23-07.....	780
31-103-22-07.....	780
31-105-22-07.....	780
31-107-22-07.....	780
31-113-16-07.....	780
31-113-17-07.....	780
31-170-01-01.....	781
31-170-02-01.....	781
31-170-03-01.....	781
31-170-04-01.....	781
31-170-05-01.....	781
31-170-06-01.....	781
31-170-07-01.....	781
31-170-08-01.....	781
31-170-09-01.....	781
31-170-10-01.....	781
31-170-11-01.....	781
31-170-12-01.....	781
31-170-13-01.....	781
31-204-20-07.....	782
31-205-20-07.....	782
31-214-20-07.....	782
31-215-20-07.....	782
31-217-22-07.....	783
31-223-23-07.....	783
31-225-23-07.....	783
31-340-01-07.....	784
31-340-02-07.....	784
31-340-03-07.....	784
31-340-04-07.....	784
31-340-05-07.....	784
31-340-06-07.....	784
31-340-07-07.....	784
31-340-08-07.....	784
31-401-21-07.....	785
31-405-21-07.....	785
31-407-22-07.....	785
31-451-24-07.....	786
31-453-24-07.....	786
31-461-23-07.....	786
31-463-23-07.....	787
31-465-24-07.....	787
31-475-00-07.....	788
31-510-00-07.....	788
31-512-00-07.....	789
31-512-90-98.....	789
31-512-91-98.....	789
31-512-92-98.....	789
31-599-00-07.....	790
31-599-08-07.....	790
31-599-10-07.....	790
31-599-12-07.....	790
31-599-14-07.....	790
31-599-16-07.....	790
31-599-18-07.....	790
31-599-20-07.....	790
31-599-22-07.....	790
31-599-24-07.....	790
31-599-26-07.....	790
31-599-28-07.....	790
31-599-30-07.....	790
31-599-32-07.....	790
31-599-34-07.....	790
31-599-36-07.....	790
31-607-10-07.....	790
31-607-11-07.....	790
31-607-12-07.....	790
31-607-13-07.....	790
31-607-14-07.....	790
31-607-15-07.....	790
31-607-16-07.....	790
31-607-17-07.....	790
31-607-18-07.....	790
31-607-19-07.....	790
31-607-20-07.....	790
31-607-21-07.....	790
31-607-22-07.....	790

Nummern-Index

Index of order numbers

Índice de números de referencia

Index numérique des références de commande

Elenco dei codici

31-607-25-07.....790
31-607-26-07.....790
31-607-27-07.....790
31-607-28-07.....790
31-607-29-07.....790
31-607-30-07.....790
31-610-13-04.....791
31-610-14-04.....791
31-610-15-04.....791
31-610-16-04.....791
31-721-12-01.....791
31-721-14-01.....791
31-740-00-07.....792
31-740-90-98.....792
31-745-00-07.....792
31-760-00-07.....793
31-763-00-04.....793
31-765-08-07.....793
31-765-11-07.....793
31-765-13-07.....793
31-765-16-07.....793
31-765-21-07.....793
31-765-26-07.....793
31-765-32-07.....793
31-766-00-07.....793
31-811-20-07.....794
31-811-28-07.....794
31-817-00-01.....794
31-817-12-07.....794
31-875-08-01.....795
31-881-11-01.....795

32

31-881-90-98.....795
32-110-01-01.....798
32-110-02-01.....798
32-110-03-01.....798
32-112-01-01.....798
32-114-01-01.....798
32-114-02-01.....798
32-114-03-01.....798
32-116-01-01.....798
32-116-02-01.....798
32-116-03-01.....798
32-120-01-01.....798
32-120-02-01.....798
32-120-03-01.....798
32-126-01-01.....799
32-126-02-01.....799
32-126-03-01.....799
32-128-01-01.....799
32-128-03-01.....799
32-130-01-01.....799
32-130-02-01.....799
32-130-03-01.....799
32-132-01-01.....799
32-132-02-01.....799
32-133-01-07.....799
32-160-01-01.....800
32-160-02-01.....800
32-160-03-01.....800
32-165-01-07.....800
32-165-02-07.....800
32-165-03-07.....800
32-182-01-01.....801
32-182-02-01.....801
32-182-03-01.....801
32-183-01-01.....801
32-183-02-01.....801
32-183-03-01.....801
32-185-01-01.....801
32-185-02-01.....801
32-185-03-01.....801
32-190-01-01.....802
32-190-02-01.....802
32-191-01-01.....802
32-191-02-01.....802
32-195-01-01.....802
32-195-02-01.....802

32-196-01-01.....803
32-196-02-01.....803
32-196-03-01.....803
32-197-01-01.....803
32-197-02-01.....803
32-197-03-01.....803
32-199-01-01.....803
32-199-02-01.....803
32-199-03-01.....803
32-202-01-01.....804
32-202-02-01.....804
32-202-03-01.....804
32-203-01-01.....804
32-203-02-01.....804
32-203-03-01.....804
32-205-01-01.....804
32-205-02-01.....804
32-205-03-01.....804
32-232-01-01.....805
32-232-02-01.....805
32-233-01-01.....805
32-233-02-01.....805
32-235-01-01.....805
32-235-02-01.....805
32-249-01-01.....806
32-249-02-01.....806
32-249-03-01.....806
32-250-01-01.....806
32-250-02-01.....806
32-250-03-01.....806
32-250-04-01.....806
32-251-01-01.....806
32-251-02-01.....806
32-251-03-01.....806
32-302-00-01.....808
32-302-01-01.....807
32-302-02-01.....807
32-302-03-01.....807
32-302-04-01.....807
32-302-05-01.....807
32-302-10-01.....808
32-302-12-01.....808
32-302-14-07.....807, 808
32-310-22-01.....809
32-310-90-98.....809
32-314-24-02.....810
32-314-99-02.....810
32-323-20-07.....810
32-323-25-07.....810
32-323-30-07.....810
32-323-35-07.....810
32-323-40-07.....810
32-324-20-07.....810
32-324-25-07.....810
32-324-30-07.....810
32-324-35-07.....810
32-324-40-07.....810
32-325-40-07.....810
32-342-24-01.....810
32-381-24-07.....811
32-383-24-07.....811
32-384-34-01.....811
32-400-01-01.....812
32-400-02-01.....812
32-400-03-01.....812
32-400-04-01.....812
32-400-05-01.....812
32-400-06-01.....812
32-400-07-01.....812
32-400-08-01.....812
32-400-09-01.....812
32-400-10-01.....812
32-400-11-01.....812
32-400-12-01.....812
32-400-13-01.....812
32-400-14-01.....812
32-400-15-01.....812
32-400-16-01.....812
32-400-17-01.....812
32-400-18-01.....812

32-400-19-01.....812
32-400-20-01.....812
32-400-21-01.....812
32-400-22-01.....812
32-400-23-01.....812
32-400-24-01.....812
32-400-25-01.....812
32-400-26-01.....812
32-400-80-01.....812
32-400-84-01.....812
32-400-90-01.....812
32-400-90-98.....812
32-401-01-01.....812
32-401-02-01.....812
32-401-03-01.....812
32-401-04-01.....812
32-401-05-01.....812
32-401-06-01.....812
32-401-07-01.....812
32-401-08-01.....812
32-401-09-01.....812
32-401-10-01.....812
32-401-11-01.....812
32-401-12-01.....812
32-401-13-01.....812
32-401-14-01.....812
32-401-15-01.....812
32-401-16-01.....812
32-401-17-01.....812
32-430-02-01.....813
32-430-04-01.....813
32-430-06-01.....813
32-430-08-01.....813
32-430-10-01.....813
32-430-12-01.....813
32-430-14-01.....813
32-430-16-01.....813
32-430-18-01.....813
32-430-20-01.....813
32-430-22-01.....813
32-430-24-01.....813
32-430-26-01.....813
32-430-80-01.....813
32-430-82-01.....814
32-430-84-01.....814
32-460-10-01.....815
32-460-12-01.....815
32-460-14-01.....815
32-460-16-01.....815
32-460-18-01.....815
32-460-20-01.....815
32-460-82-01.....815
32-583-32-01.....816
32-584-32-02.....816
32-593-25-01.....816
32-595-26-07.....816
32-622-25-07.....817
32-628-25-07.....817
32-645-28-07.....817
32-659-26-07.....817
32-663-24-07.....818
32-682-24-07.....818
32-683-24-07.....818
32-697-23-07.....818
32-699-26-07.....819
32-702-24-07.....819
32-704-24-07.....819
32-706-24-07.....819
32-728-21-07.....819
32-734-26-07.....820
32-738-16-07.....820
32-740-21-07.....820
32-741-32-07.....821
32-744-27-07.....821
32-745-25-07.....821
32-758-17-07.....822
32-760-17-07.....822
32-762-27-07.....822
32-773-27-07.....823
32-779-23-07.....823

32-793-25-07.....823
32-801-23-07.....824
32-804-03-07.....824
32-806-22-07.....824
32-808-22-07.....824
32-825-23-01.....825
32-827-30-07.....825
32-829-27-07.....825
32-841-23-07.....826
32-843-21-07.....826
32-846-21-07.....826
32-846-28-07.....826
32-851-22-07.....827
32-851-24-07.....827
32-853-26-07.....827
32-855-24-07.....828
32-855-25-07.....828
32-857-28-07.....829
32-859-32-07.....829
32-861-02-07.....829
32-865-00-07.....830
32-865-01-07.....830
32-866-22-07.....830
32-866-28-07.....830
32-900-01-07.....831
32-900-02-07.....831
32-900-03-07.....831
32-900-04-07.....831
32-900-05-07.....831
32-900-06-07.....831
32-906-01-07.....831
32-906-02-07.....831
32-906-03-07.....831
32-906-04-07.....831
32-906-05-07.....831
32-906-06-07.....831
32-919-00-07.....831
32-920-05-07.....832
32-920-06-07.....832
32-920-07-07.....832
32-920-08-07.....832
32-920-09-07.....832
32-920-11-07.....832
32-920-12-07.....832
32-920-14-07.....832
32-920-15-07.....832
32-920-16-07.....832
32-920-19-07.....832
32-920-20-07.....832
32-920-21-07.....832
32-920-23-07.....832
32-920-25-07.....832
32-920-30-07.....832
32-920-35-07.....832
32-920-40-07.....832
32-921-05-07.....832
32-921-06-07.....832
32-921-07-07.....832
32-921-08-07.....832
32-921-09-07.....832
32-921-11-07.....832
32-921-12-07.....832
32-921-14-07.....832
32-921-15-07.....832
32-921-16-07.....832
32-921-19-07.....832
32-921-20-07.....832
32-921-21-07.....832
32-921-23-07.....832
32-921-25-07.....832
32-921-30-07.....832
32-921-35-07.....832
32-921-40-07.....832
32-924-10-07.....834
32-924-12-07.....834
32-924-14-07.....834
32-926-05-07.....832
32-926-06-07.....832
32-926-07-07.....832
32-926-08-07.....832

32-926-09-07.....832
32-926-11-07.....832
32-926-12-07.....832
32-926-14-07.....832
32-926-15-07.....832
32-926-16-07.....832
32-926-19-07.....832
32-926-20-07.....832
32-926-21-07.....832
32-926-23-07.....832
32-926-25-07.....832
32-926-30-07.....832
32-926-35-07.....832
32-926-40-07.....832
32-927-05-07.....832
32-927-06-07.....832
32-927-07-07.....832
32-927-08-07.....832
32-927-09-07.....832
32-927-11-07.....832
32-927-12-07.....832
32-927-14-07.....832
32-927-15-07.....832
32-927-16-07.....832
32-927-19-07.....832
32-927-20-07.....832
32-927-21-07.....832
32-927-23-07.....832
32-927-25-07.....832
32-927-30-07.....832
32-927-35-07.....832
32-927-40-07.....832
32-989-03-01.....834
32-989-04-01.....834
32-989-06-01.....834
32-989-08-01.....834
32-989-10-01.....834
32-989-12-01.....834
32-989-14-01.....834
32-989-50-01.....834
32-995-00-02.....835
32-995-01-02.....835
32-995-02-02.....835

33

33-103-34-07.....838
33-141-36-07.....838
33-141-40-07.....838
33-145-30-07.....838
33-146-28-07.....838
33-149-36-07.....838
33-195-41-07.....839
33-197-40-07.....839
33-198-44-07.....839
33-300-21-07.....840
33-309-28-07.....840
33-328-27-07.....840
33-329-27-07.....840
33-344-01-07.....840
33-344-02-07.....840
33-345-01-07.....840
33-345-02-07.....840
33-382-01-07.....841
33-382-02-07.....841
33-382-03-07.....841
33-386-30-07.....842
33-465-09-07.....842

34

34-370-01-07.....844
34-370-02-07.....844

35

35-133-06-07.....844
35-133-07-07.....844
35-133-09-07.....844
35-134-09-07.....844
35-134-18-07.....844
35-220-00-18.....845
35-220-11-18.....845

Nummern-Index

Index of order numbers

Índice de números de referencia

Index numérique des références de commande

Elenco dei codici

35-220-22-18.....845
35-220-33-18.....845
35-220-44-18.....845
35-220-55-18.....845
35-220-66-18.....845
35-220-77-18.....845
35-220-88-18.....845
35-224-00-18.....845
35-224-01-18.....845
35-224-12-18.....845
35-224-23-18.....845
35-224-34-18.....845
35-224-45-18.....845
35-224-56-18.....845
35-224-67-18.....845
35-224-78-18.....845
35-224-99-18.....845
35-226-00-18.....845
35-226-01-18.....845
35-226-12-18.....845
35-226-23-18.....845
35-226-34-18.....845
35-226-45-18.....845
35-226-56-18.....845
35-226-67-18.....845
35-226-78-18.....845

36

36-001-01-02.....848
36-001-01-07.....848
36-001-06-02.....848
36-001-06-07.....848
36-001-07-02.....848
36-001-07-07.....848
36-001-08-02.....848
36-001-08-07.....848
36-001-09-02.....848
36-001-09-07.....848
36-001-11-02.....849
36-001-11-07.....849
36-001-16-02.....849
36-001-16-07.....849
36-001-21-02.....850
36-001-21-07.....850
36-001-26-02.....851
36-001-26-07.....851
36-001-27-02.....851
36-001-27-07.....851
36-001-28-02.....851
36-001-28-07.....851
36-001-29-02.....851
36-001-29-07.....851
36-003-01-02.....852
36-003-01-07.....852
36-003-02-02.....852
36-003-02-07.....852
36-003-03-02.....852
36-003-03-07.....852
36-003-04-02.....852
36-003-04-07.....852
36-003-11-02.....853
36-003-11-07.....853
36-003-12-02.....853
36-003-12-07.....853
36-003-13-02.....853
36-003-13-07.....853
36-003-14-02.....853
36-003-14-07.....853
36-005-01-02.....854
36-005-01-07.....854
36-005-02-02.....854
36-005-02-07.....854
36-005-03-02.....854
36-005-03-07.....854
36-005-04-02.....854
36-005-04-07.....854
36-005-51-02.....855
36-005-51-07.....855
36-005-52-02.....855

36-005-52-07.....855
36-005-53-02.....855
36-005-53-07.....855
36-005-54-02.....855
36-005-54-07.....855
36-010-11-02.....856
36-010-11-07.....856
36-010-12-02.....856
36-010-12-07.....856
36-011-01-02.....857
36-011-01-07.....857
36-011-02-02.....857
36-011-02-07.....857
36-011-06-02.....857
36-011-06-07.....857
36-011-07-02.....857
36-011-07-07.....857
36-013-01-02.....858
36-013-01-07.....858
36-020-06-07.....859
36-020-11-07.....859
36-020-16-07.....859
36-020-21-07.....859
36-022-01-07.....859
36-022-02-07.....859
36-022-03-07.....859
36-022-04-07.....859
36-022-05-07.....859
36-022-06-07.....859
36-022-07-07.....859
36-024-01-07.....860
36-024-02-07.....860
36-024-03-07.....860
36-024-04-07.....860
36-024-06-07.....860
36-024-07-07.....860
36-024-08-07.....860
36-024-11-07.....860
36-024-12-07.....860
36-024-13-07.....860
36-024-14-07.....860
36-024-15-07.....860
36-024-16-07.....860
36-024-17-07.....860
36-024-21-07.....860
36-024-22-07.....860
36-024-23-07.....860
36-024-24-07.....860
36-024-25-07.....860
36-024-26-07.....860
36-024-27-07.....860
36-024-31-07.....860
36-024-32-07.....860
36-025-01-07.....861
36-025-02-07.....861
36-025-03-07.....861
36-025-06-07.....861
36-025-07-07.....861
36-025-08-07.....861
36-027-01-07.....861
36-027-02-07.....861
36-027-11-07.....861
36-027-12-07.....861
36-029-01-07.....861
36-029-06-07.....861
36-030-06-07.....862
36-030-07-07.....862
36-030-08-07.....862
36-030-11-07.....862
36-030-12-07.....862
36-030-13-07.....862
36-030-20-07.....862
36-030-30-07.....862
36-036-01-07.....862
36-036-02-07.....862
36-036-05-07.....862
36-036-06-07.....862
36-036-23-07.....862
36-038-01-07.....863
36-038-02-07.....863

36-038-03-07.....863
36-038-04-07.....863
36-044-01-07.....863
36-044-02-07.....863
36-044-03-07.....863
36-112-03-01.....864
36-112-10-01.....864
36-112-11-01.....864
36-112-12-01.....864
36-112-13-01.....864
36-112-14-01.....864
36-114-03-01.....864
36-115-04-01.....864
36-118-03-01.....864
36-118-11-01.....864
36-118-12-01.....864
36-118-13-01.....864
36-118-14-01.....864
36-119-04-01.....864
36-132-00-04.....865
36-132-01-04.....865
36-132-02-04.....865
36-132-03-04.....865
36-132-04-04.....865
36-132-05-04.....865
36-132-06-04.....865
36-134-01-07.....865
36-134-02-07.....865
36-134-03-07.....865
36-134-04-07.....865
36-134-05-07.....865
36-134-06-07.....865
36-134-07-07.....865
36-148-12-01.....865
36-170-07-04.....866
36-172-08-04.....866
36-174-09-04.....866
36-175-10-04.....866
36-177-11-04.....866
36-180-10-04.....867
36-182-11-04.....867
36-184-12-04.....867
36-186-13-04.....867
36-188-14-04.....867
36-189-10-04.....867
36-192-11-04.....867
36-194-12-04.....867
36-196-13-04.....867
36-198-14-04.....867
36-200-15-04.....867
36-210-10-04.....868
36-212-11-04.....868
36-214-12-04.....868
36-216-13-04.....868
36-216-90-98.....868
36-218-14-04.....868
36-220-15-04.....868
36-221-10-04.....868
36-221-91-98.....868
36-222-10-04.....868
36-223-11-04.....868
36-223-90-98.....868
36-224-10-04.....869
36-224-90-98.....869
36-224-91-98.....869
36-224-92-98.....869
36-224-93-98.....869
36-226-00-04.....869
36-230-59-04.....869
36-234-61-04.....869
36-234-90-98.....869
36-316-11-07.....870
36-321-01-01.....870
36-321-02-01.....870
36-321-03-01.....870
36-351-16-07.....870
36-353-16-07.....870
36-353-90-98.....870
36-358-30-01.....870
36-358-40-01.....870

36-371-11-07.....871
36-375-12-07.....871
36-381-13-07.....871
36-391-14-07.....871
36-395-16-07.....871
36-395-20-07.....871
36-405-12-07.....872
36-407-14-07.....872
36-416-11-07.....872
36-418-10-07.....872
36-425-08-07.....873
36-427-08-07.....873
36-430-08-07.....873
36-430-14-07.....873
36-442-81-07.....873
36-442-82-07.....873
36-442-83-07.....873
36-445-08-07.....873
36-448-08-07.....873
36-456-08-07.....873
36-461-17-07.....874
36-463-19-07.....875
36-466-14-07.....875
36-491-13-07.....876
36-493-01-07.....876
36-493-02-07.....876
36-495-02-07.....876
36-495-10-07.....876
36-495-11-07.....876
36-495-12-07.....876
36-497-01-07.....876
36-497-02-07.....876
36-497-10-07.....876
36-497-11-07.....876
36-497-12-07.....876
36-497-13-07.....876
36-497-14-07.....876
36-498-01-07.....876
36-498-02-07.....876
36-498-10-07.....876
36-498-11-07.....876
36-498-12-07.....876
36-498-13-07.....876
36-498-14-07.....876
36-532-15-07.....877
36-543-12-07.....877
36-551-01-07.....877
36-554-01-07.....877
36-554-02-07.....877
36-554-03-07.....877
36-561-16-07.....877
36-563-16-07.....877
36-570-16-07.....877
36-577-01-07.....877
36-577-02-07.....877
36-577-03-07.....877
36-585-01-07.....878
36-585-02-07.....878
36-585-03-07.....878
36-585-04-07.....878
36-585-05-07.....878
36-585-06-07.....878
36-585-07-07.....878
36-589-01-07.....878
36-589-02-07.....878
36-630-16-07.....878
36-655-16-07.....878
36-657-16-07.....878
36-661-18-07.....878
36-663-18-07.....878
36-737-20-07.....879
36-739-17-07.....879
36-743-10-07.....879
36-743-20-07.....879
36-743-30-07.....879
36-743-40-07.....879
36-743-50-07.....879
36-780-00-01.....880
36-780-01-04.....880
36-780-08-01.....880

36-780-11-01.....880
36-780-13-01.....880
36-780-50-04.....880
36-780-90-98.....880
36-780-91-98.....880
36-780-92-98.....880
36-786-00-02.....880
36-786-01-02.....880
36-792-00-02.....881
36-792-01-02.....881
36-792-02-02.....881
36-792-03-02.....881
36-792-04-02.....881
36-792-15-02.....881
36-792-17-02.....881
36-792-22-02.....881
36-792-50-04.....881
36-794-00-02.....882
36-794-02-02.....882
36-794-03-04.....882
36-794-04-02.....882
36-794-05-02.....882
36-794-06-02.....882
36-794-07-02.....882
36-794-08-02.....882
36-794-09-02.....882
36-794-90-98.....882
36-794-91-98.....882
36-795-00-02.....883
36-795-01-02.....882
36-795-04-02.....883
36-795-90-98.....883
36-795-91-98.....883
36-795-92-98.....883
36-817-01-01.....884
36-817-02-01.....884
36-817-03-01.....884
36-845-01-07.....884
36-845-02-07.....884
36-845-03-07.....884
36-848-13-07.....885
36-849-13-07.....885
36-852-13-07.....885
36-856-01-07.....885
36-856-02-07.....885
36-856-03-07.....885
36-856-04-07.....885
36-858-14-07.....886
36-859-35-07.....886
36-859-50-07.....886
36-859-75-07.....886
36-859-90-07.....886
36-861-45-07.....887
36-861-75-07.....887
36-885-26-07.....888
36-887-26-07.....888
36-898-30-11.....888
36-898-40-11.....888
36-899-12-01.....888

37

37-101-15-07.....890
37-105-18-07.....890
37-115-16-07.....890
37-115-20-07.....890
37-121-20-07.....890
37-129-20-07.....890
37-145-20-07.....890
37-207-18-07.....891
37-213-18-07.....891
37-215-01-07.....891
37-215-02-07.....891
37-227-01-07.....891
37-227-02-07.....891
37-227-03-07.....891
37-227-04-07.....891
37-235-12-07.....892
37-237-12-07.....892
37-241-10-07.....893

Index

Index

Indice

Index

Indice



Nummern-Index

Index of order numbers

Índice de números de referencia

Index numérique des références de commande

Elenco dei codici

37-241-12-07.....893	37-543-19-07.....907	37-670-21-07.....917	37-842-30-07.....926	39-782-10-04.....940
37-249-12-07.....893	37-544-01-07.....907	37-671-21-07.....918	37-842-40-07.....926	39-782-12-04.....940
37-255-01-07.....894	37-544-02-07.....907	37-673-21-07.....918	37-851-05-04.....880	39-782-14-04.....940
37-255-02-07.....894	37-545-18-07.....908	37-674-18-07.....918		39-782-16-04.....940
37-255-03-07.....894	37-546-18-07.....908	37-676-18-07.....918		39-782-18-04.....940
37-255-04-07.....894	37-547-20-07.....908	37-680-01-07.....919		39-782-20-04.....940
37-255-05-07.....894	37-549-22-07.....908	37-680-02-07.....919	39	39-782-22-04.....940
37-256-01-07.....894	37-550-19-07.....909	37-680-03-07.....919	39-001-18-07.....932	39-782-24-04.....940
37-256-02-07.....894	37-557-22-07.....909	37-680-04-07.....919	39-003-18-07.....932	39-782-26-04.....940
37-256-03-07.....894	37-559-23-07.....909	37-680-05-07.....919	39-011-18-07.....932	39-782-28-04.....940
37-256-04-07.....894	37-560-18-07.....909	37-680-06-07.....919	39-013-18-07.....932	39-782-30-04.....940
37-258-01-07.....894	37-562-22-07.....909	37-680-07-07.....919	39-021-18-07.....932	39-785-08-01...940, 941
37-258-02-07.....894	37-568-21-07.....910	37-680-08-07.....919	39-023-18-07.....932	39-785-10-01.....940
37-258-03-07.....894	37-572-19-07.....910	37-680-09-07.....919	39-027-18-07.....932	39-785-12-01.....940
37-258-04-07.....894	37-579-22-07.....910	37-680-10-07.....919	39-101-18-07.....932	39-785-14-01.....940
37-259-12-07.....895	37-581-22-07.....910	37-680-21-07.....918	39-102-18-07.....932	39-785-16-01.....940
37-260-12-07.....895	37-583-21-07.....910	37-682-01-07.....920	39-220-22-07.....933	39-785-18-01.....940
37-261-12-07.....895	37-584-21-07.....910	37-682-02-07.....920	39-228-23-07.....933	39-785-20-01.....940
37-285-01-07.....896	37-585-16-07.....910	37-682-03-07.....920	39-269-25-07.....933	39-785-22-01.....940
37-308-01-07.....897	37-593-16-07.....911	37-682-04-07.....920	39-281-22-07.....933	39-785-24-01.....940
37-308-02-07.....897	37-594-16-07.....911	37-682-05-07.....920	39-289-23-07.....934	39-785-26-01.....940
37-308-03-07.....897	37-595-15-07.....911	37-682-06-07.....920	39-291-23-07.....934	39-785-28-01.....940
37-309-01-07.....898	37-597-02-07.....911	37-684-15-07.....921	39-311-19-07.....934	39-785-30-01.....940
37-309-02-07.....898	37-597-04-07.....911	37-686-16-07.....921	39-311-20-07.....934	39-786-08-04.....940
37-309-03-07.....898	37-597-06-07.....911	37-687-17-07.....921	39-313-17-07.....934	39-786-10-04.....940
37-309-04-07.....898	37-597-08-07.....911	37-688-01-07.....921	39-419-18-07.....935	39-786-12-04.....940
37-313-12-07.....898	37-601-16-07.....911	37-688-02-07.....921	39-423-20-07.....935	39-786-14-04.....940
37-323-19-07.....899	37-605-16-07.....911	37-688-03-07.....921	39-443-19-07.....935	39-786-16-04.....940
37-327-19-07.....899	37-606-04-07.....912	37-692-22-07.....921	39-445-19-07.....935	39-786-18-04.....940
37-331-20-07.....899	37-606-07-07.....912	37-694-17-07.....921	39-447-19-07.....935	39-786-20-04.....940
37-334-21-07.....899	37-606-09-07.....912	37-697-19-07.....921	39-449-19-07.....935	39-786-22-04.....940
37-335-01-07.....900	37-606-12-07.....912	37-698-10-07.....922	39-500-28-07.....936	39-786-24-04.....940
37-335-20-07.....900	37-607-06-07.....912	37-699-11-07.....922	39-502-28-07.....936	39-786-26-04.....940
37-335-21-07.....900	37-608-02-07.....912	37-700-12-07.....922	39-506-28-07.....936	39-786-28-04.....940
37-337-21-07.....900	37-608-04-07.....912	37-702-15-07.....922	39-511-40-07.....936	39-786-30-04...940, 941
37-340-13-07.....901	37-608-07-07.....912	37-704-02-07.....922	39-511-50-07.....936	39-789-12-02.....941
37-341-13-07.....901	37-608-09-07.....912	37-704-05-07.....922	39-513-01-07.....936	39-789-14-02.....941
37-342-12-07.....901	37-608-12-07.....912	37-704-07-07.....922	39-525-01-07.....936	39-789-16-02.....941
37-343-12-07.....901	37-609-06-07.....912	37-704-10-07.....922	39-541-13-07.....937	39-789-18-02.....941
37-356-17-07.....902	37-610-16-07.....912	37-706-16-07.....922	39-541-15-07.....937	39-794-11-02.....941
37-357-17-07.....902	37-612-16-07.....912	37-707-20-07.....923	39-581-01-07.....830	39-798-12-02.....941
37-360-17-07.....902	37-616-10-07.....913	37-708-14-07.....923	39-584-20-07.....830	39-814-01-07.....942
37-361-17-07.....902	37-616-12-07.....913	37-709-01-07.....923	39-584-30-07.....830	39-814-02-07.....942
37-362-03-07.....902	37-616-14-07.....913	37-709-02-07.....923	39-584-40-07.....830	39-814-03-07.....942
37-362-05-07.....902	37-620-03-07.....913	37-710-14-07.....923	39-587-20-07.....937, 938, 939	39-814-04-07.....942
37-364-02-07.....903	37-620-04-07.....913	37-712-16-07.....923	39-600-01-07.....938	
37-364-03-07.....903	37-622-03-07.....913	37-713-15-07.....923	39-604-01-07.....938	
37-364-04-07.....903	37-622-04-07.....913	37-714-15-07.....923	39-608-01-07.....938	54
37-364-05-07.....903	37-622-07-07.....913	37-715-14-07.....923	39-611-01-07.....938	54-100-01-04.....948
37-364-06-07.....903	37-622-09-07.....913	37-721-20-07.....924	39-613-01-07.....938	54-150-10-01.....948
37-365-02-07.....903	37-622-12-07.....913	37-724-01-07.....924	39-616-02-07.....938	54-150-20-01.....948
37-365-03-07.....903	37-623-04-07.....913	37-724-02-07.....924	39-616-03-07.....938	54-155-25-04.....949
37-365-04-07.....903	37-623-05-07.....913	37-724-03-07.....924	39-618-02-07.....938	54-160-20-01.....949
37-367-02-07.....903	37-623-06-07.....913	37-725-23-07.....924	39-618-03-07.....938	54-301-10-07.....950
37-367-03-07.....903	37-623-07-07.....913	37-728-11-07.....925	39-624-01-07.....938	54-305-10-07.....950
37-367-04-07.....903	37-624-10-07.....914	37-731-14-07.....925	39-628-01-07.....939	54-331-14-07.....950
37-389-00-07.....904	37-624-12-07.....914	37-732-10-07.....925	39-628-02-07.....939	54-336-14-07.....950
37-389-01-07.....904	37-624-14-07.....914	37-742-21-07.....925	39-632-01-07.....939	54-336-16-07.....950
37-389-02-07.....904	37-624-16-07.....914	37-748-01-07.....925	39-637-01-07.....939	54-341-11-07.....950
37-389-03-07.....904	37-625-01-07.....914	37-748-02-07.....925	39-637-02-07.....939	54-341-13-07.....950
37-440-01-07.....905	37-625-02-07.....914	37-748-03-07.....925	39-637-03-07.....939	54-347-13-07.....950
37-441-01-07.....905	37-625-03-07.....914	37-748-04-07.....925	39-637-04-07.....939	54-353-12-07.....950
37-444-16-07.....905	37-628-01-07.....914	37-748-05-07.....925	39-639-01-07.....939	54-360-11-07.....951
37-459-16-07.....905	37-628-02-07.....914	37-748-06-07.....925	39-643-01-07.....939	54-360-13-07.....951
37-466-15-07.....905	37-628-03-07.....914	37-755-01-07.....926	39-643-02-07.....939	54-360-15-07.....951
37-468-15-07.....905	37-629-01-07.....914	37-755-02-07.....926	39-647-01-07.....939	54-365-11-07.....951
37-484-15-07.....906	37-632-20-07.....915	37-755-03-07.....926	39-657-01-07.....939	54-365-13-07.....951
37-497-19-07.....906	37-634-20-07.....915	37-755-04-07.....926	39-781-08-01.....940	54-373-10-07.....951
37-499-19-07.....906	37-649-00-07.....915	37-755-05-07.....926	39-781-10-01.....940	54-378-10-07.....951
37-504-03-07.....906	37-649-01-07.....915	37-755-06-07.....926	39-781-12-01.....940	54-378-12-07.....951
37-504-04-07.....906	37-649-02-07.....915	37-756-01-07.....926	39-781-14-01.....940	54-379-10-07.....951
37-504-05-07.....906	37-650-01-07.....916	37-756-02-07.....926	39-781-16-01.....940	54-379-12-07.....951
37-505-03-07.....906	37-650-02-07.....916	37-756-03-07.....926	39-781-18-01.....940	54-386-10-07.....951
37-505-04-07.....906	37-652-00-07.....916	37-756-04-07.....926	39-781-20-01.....940	54-388-11-07.....951
37-505-05-07.....906	37-656-01-07.....917	37-756-05-07.....926	39-781-22-01.....940	54-389-16-04.....951
37-521-04-07.....907	37-656-02-07.....917	37-756-06-07.....926	39-781-24-01.....940	54-406-00-04.....952
37-521-05-07.....907	37-658-01-07.....917	37-814-30-07.....926	39-781-26-01.....940	54-410-01-04.....952
37-525-16-07.....907	37-669-01-07.....917	37-816-30-07.....926	39-781-28-01.....940	54-410-05-04.....952
37-531-16-07.....907	37-669-02-07.....917	37-840-20-01.....926	39-781-30-01.....940	54-410-06-04.....952
37-541-19-07.....907	37-669-03-07.....917	37-840-90-98.....926	39-782-08-04.....940	39-814-04-07.....942

55

55-085-27-07.....	956
55-091-30-07.....	956
55-141-10-01.....	956
55-142-10-01.....	956
55-162-20-01.....	957
55-164-20-01.....	957
55-300-50-01.....	957
55-300-65-01.....	957
55-300-75-01.....	957
55-302-50-01.....	957
55-302-65-01.....	957
55-302-75-01.....	957
55-309-65-01.....	958
55-310-65-01.....	958
55-335-01-01.....	958
55-335-02-01.....	958
55-335-03-01.....	958
55-335-05-01.....	958
55-337-01-01.....	959
55-337-02-01.....	959
55-340-02-01.....	959
55-348-00-01.....	959
55-348-01-01.....	959
55-358-25-01.....	960
55-358-32-01.....	960
55-805-14-01.....	960
55-808-14-01.....	960
39-814-04-07.....	942

56

56-176-33-01.....	962
56-178-33-01.....	962
56-231-04-01.....	962
56-231-06-01.....	962
56-231-08-01.....	962
56-231-11-01.....	962
56-231-12-01.....	962
56-231-14-01.....	962
56-231-16-01.....	962
56-231-18-01.....	962
56-235-11-01.....	962
56-235-12-01.....	962
56-235-14-01.....	962
56-235-16-01.....	962
56-235-18-01.....	962
56-254-01-01.....	962
56-256-02-01.....	962
56-256-05-01.....	962
56-256-10-01.....	962
56-256-20-01.....	962
56-321-23-01.....	963
56-321-30-01.....	963
56-321-31-01.....	963
56-321-35-01.....	963
56-321-40-01.....	963
56-324-21-01.....	963
56-324-24-01.....	963
56-324-30-01.....	963
56-324-31-01.....	963
56-324-35-01.....	963
56-324-40-01.....	963
56-324-42-01.....	963
56-340-23-01.....	963
56-348-22-01.....	963
56-360-30-01.....	964
56-360-50-01.....	964
56-360-51-01.....	964
56-360-52-01.....	964
56-360-75-01.....	964
56-360-76-01.....	964
56-360-77-01.....	964
56-360-98-01.....	964
56-360-99-01.....	964
56-411-16-01.....	964
56-411-20-01.....	964
56-411-21-01.....	964
56-411-23-01.....	964
56-411-26-01.....	964
56-411-27-01.....	964

56-411-30-01.....	964
56-411-33-01.....	964
56-419-20-01.....	964
56-431-06-01.....	965
56-431-10-01.....	965
56-432-08-01.....	965
56-432-12-01.....	965
56-435-15-01.....	965
56-673-17-01.....	965
56-673-25-01.....	965
56-673-27-01.....	965
56-675-25-01.....	965

73

73-101-00-04.....	968
73-101-01-04.....	968, 969
73-101-02-04.....	969
73-101-03-04.....	969
73-101-04-04.....	969
73-101-05-04.....	969
73-101-06-04.....	969
73-101-07-04.....	969
73-101-08-04.....	969
73-101-09-04.....	968, 969
73-101-20-04.....	968
73-102-02-04.....	969
73-102-03-04.....	969
73-301-03-04.....	970
73-303-03-04.....	970
73-304-07-04.....	970
73-306-08-04.....	970
73-306-12-04.....	970
73-306-13-04.....	970
73-306-15-04.....	970
73-308-20-04.....	970
73-308-25-04.....	970
73-308-30-04.....	970
73-315-00-04.....	971
73-315-13-04.....	971
73-315-15-04.....	971
73-315-20-04.....	971
73-315-25-04.....	971
73-315-28-04.....	971
73-318-12-04.....	971
73-318-15-04.....	971
73-318-30-04.....	971
73-318-50-04.....	971
73-324-35-04.....	972
73-326-40-04.....	972
73-327-60-04.....	972
73-333-80-04.....	972
73-335-60-04.....	972
73-340-75-04.....	972
73-351-50-04.....	972
73-356-15-04.....	973
73-359-18-04.....	973
73-361-15-04.....	973
73-365-08-04.....	973
73-367-16-04.....	973
73-370-95-04.....	973
73-454-15-01.....	974
73-455-15-01.....	974
73-470-58-07.....	974
73-474-55-07.....	974

Index, alphabetisch
Deutsch



A			
Abfalleimer	974		
Abfallzange	974		
Abortuskürette	842		
Abortuslöffel	841		
Abortuszange	840		
Absaugkürette	834		
Abziehstein	16		
Adlerkreuz, Chirurgische Pinzette	151		
Adson, Anatomische Pinzette	140, 144		
Adson, Chirurgische Pinzette	144, 152		
Adson, Durahaken	696		
Adson, Elevatorium	510		
Adson, Nadelhalter	413		
Adson, Präparierklemme	192		
Adson, Saugkanüle	360		
Adson, Wundspreizer	304-306, 313-314, 318		
Adson-Baby, Präparierklemme	201		
Adson-Brown, Chirurgische Pinzette	144, 155		
Alan-Parks, Analspreizer	775		
Alderdyce, Doppeldissektor	513		
Alexander, Doppelraspatorium	508		
Alexander, Flachmeißel	467		
Alexander, Hohlmeißel	467		
Alexander, Probeexzisionszange	829		
Allen, Kinderdarmklemme	758		
Allenberg-Cobra, Mehrzweck-Gefäßklemme	664		
Allis, Darm- und Gewebefasszange	750-751		
Allis-Adair, Darm- und Gewebefasszange	751		
Allis-Baby, Darm- und Gewebefasszange	750		
Allison, Lungenspatel	586		
Alm, Wundspreizer	300		
Amniotom	817		
Amputationretractor	535		
Amputationsmesser	15		
Analspreizer	775		
Anastomosenklemme	615, 631-632, 642,		
.....	657-658, 660, 662, 664		
Anatomische Pinzette	138-147, 154-155,		
.....	160, 446-447		
Anatomisches Skalpell	2		
Anderson-Adson, Wundspreizer	301		
Aneurysmaklemme	634		
Anlege- und Abnehmzange	685		
Anlegezange	612		
Ansatz	792		
Antrumkürette	925		
Antrumraspel	917		
Antrumstanze	897, 904		
Anoskop	774		
Aorta-Aneurysmaklemme	619-620		
Aorta-Dilatator	665		
Aortahaken	281-282		
Aortaklemme	595, 601-602, 606-609,		
.....	621, 624-625, 633, 655		
Aortastanze	557		
Applikations-Handgriff	916		
Approximator	172-174		
Aquila, Hysterektomieschere	132-133		
Arruga, Mikro-Nadelhalter	408		
Arruga, Nadelhalter	411, 422		
Arterienklemme	182-199, 218,		
.....	446-447, 594, 638		
Asch, Septumrichtzange	924		
Aston, Face-lift Schere	57		
Atraumatische Mikropinzette	165		
Atraumatische Pinzette	142, 147-148		
Atriumhaken	289		
Attikusdissektor	862		
Auffangsieb	810		
Aufricht, Glabellaraspel	918		
Aufricht, Nasenhaken	921, 923		
Aufsatz	830		
Aurikelklemme	629		
Austin, Attikusdissektor	862		
Austin, Mikro-Knüpfpinzette	167		
Auswaschbürste	973		
Auvard, Vaginalsekulum	809		
Ayre, Konisationsmesser	824		
B			
Babcock, Darm- und Gewebefasszange	752-753		
Baby-Poole, Sauger	368		
Backhaus, Tuchklemme	226		
Bailey, Rippenkontraktor	584		
Bailey-Baby, Rippenkontraktor	584		
Bailey-Gibbon, Rippenkontraktor	584		
Bainbridge, Mehrzweck-Gefäßklemme	618		
Bakeliffuss	869		
Bakes, Gallenkanaldilatator	781		
Balfour, Bauchdeckenhalter	332-333		
Balfour, Mittelvalve	332, 334-335		
Balfour, Mod. USA, Bauchdeckenhalter	335		
Balfour, Mod. USA, Drahtvalven	335		
Balfour-Baby, Bauchdeckenhalter	331		
Balfour-Standard, Bauchdeckenhalter	334		
Ballenger, Schwingmesser	906		
Ballenger, Septum-Hohlmeißel	911		
Ballenger-Hajek, Septumellevatorium	909		
Barbara, Mikro-Ohrhaken	860		
Barbara, Mikro-Ohrnadel	860-861		
Baron-Schuknecht, Sauger	363		
Barraquer, Cilienpinzette	169		
Barraquer, Mikro-Nadelhalter	409, 423		
Barraquer-Troutman, Mikro-Nadelhalter	408		
Batteriecontainer	398		
Batteriehandgriff	391		
Bauchdeckenhalter	324-338		
Bauchspatel	293, 344		
Beacham, Amniotom	817		
Beck, Mehrzweck-Gefäßklemme	642, 651		
Beckenhaken	292-293		
Beckenzirkel	838		
Beckman-Adson, Wundspreizer	319		
Beckman-Eaton, Wundspreizer	320		
Beckmann, Ringmesser	926		
Beckmann, Wundspreizer	317		
Beebe, Drahtschere	122		
Beer, Cilienpinzette	169		
Bellucci, Mikro-Ohrscherchen	854		
Bengolea, Arterienklemme	195		
Bennett, Knochenheber	518		
Benson, Pyloruspreizer	761		
Bereitstellungsbecher	959		
Bergmann, Gipsschere	451		
Bergmann, Schwammzange	236		
Bernhard, Tuchklemme	227		
Beschneidungsinstrument	793		
Bethune, Rippenschere	555		
Beyer, Hohlmeißelzange	539		
Beyer, Ohr-Knochenstanze	875		
Biemer, Gefäßclip	172		
Biemer, Mikro-Venenschere	116		
Biemer-Müller, Approximator	173		
Billeau, Ohrschlinge	877		
Biopsiefasszange	777		
Biopsiekürette	825		
Bircher-Ganske, Knorpelzange	525		
Blake, Gallensteinzange	782		
Blake, Uteruskürette	831		
Blasenhalssperrerr	788		
Blasenwundsperrerr	788-789		
Blattvalve	341		
Blohmke, Tonsillenzange	935		
Blount, Kniehaken	519		
Blount, Knochenheber	519		
Blumenthal, Hohlmeißelzange	538		
Böhler, Hohlmeißelzange	539		
Böhler, Knochensplitterzange	546		
Bonney, Chirurgische Pinzette	143, 158		
Borowski, Aortahaken	282		
Bowman, Sonde	845		
Boys-Allis, Darm- und Gewebefasszange	751		
Bozemann, Nadelhalter	429		
Bozemann, Schlingendreher	443		
Bozemann, Schwammzange	235		
Braun, Hakenzange	817, 820		
Braun, Uterusdepressor	816		
Braun-Stadler, Dammschere	97		
Breisky, Vaginalsekulum	810		
Brom, Venenhäkchen	248		
Brompton, Rollenklemme	230		
Bronchusklemme	587-588, 630		
Brophy, Chirurgische Pinzette	153		
Brown, Nadelhalter	413		
Bruchsonde	441		
Brünings, Kehlkopfrohr	937, 938, 939		
Brünings, Septumzange	891		
Brünings, Tonsillennmesser	933		
Brünings, Tonsillenschnürer	936		
Brünings, Verlängerungsrohr	830		
Brünings, Zangenaußensatz	938		
Brunner, Führungshohlsonde	440, 442		
Brunner, Rektum-Anastomosenklemmen	770		
Brunner, Rippenschere	556		
Brunner, Unterbindungsnadel	440		
Brunner, Wundhaken	278-279		
Bruns, Gipsschere	452, 454		
Bruns, Scharfer Löffel	492-493		
Buck, Fremdkörperzängchen	872		
Buck, Ligaturschere	120		
Buck, Ohrkürette	876		
Buckley, Wundspreizer	299		
Bulldogklemme	176-181, 589,		
.....	590-592, 611-612		
Bürettenbürste	973		
Burford, Rippensperrerr	560		
Bürstenabwurfbehälter	949		
Bürstenspender	948		
Busch, Nabelschnurschere	98		
Bushe, Scharfer Löffel	495		
Byrd, Saugrohr	373		
C			
Calne, Vena Cava-Klemme	625		
Caplan, Septumschere	899		
Carotis-Bulldogklemme	593		
Carotisklemme	659		
Carotis-Shuntklemme	599		
Carpenter, Tonsillennmesser/Enukleator	933		
Caspar, Fadengabel	705		
Caspar, Laminektomiezangen	724-729		
Caspar, Metallstößel	483		
Caspar, Mikro-Dissektor	705		
Caspar, Mikroschere	700		
Caspar, Nerv- und Gefäßhäkchen	709		
Castañeda, Neonatal-Gefäßklemme	677		
Castañeda, Rippensperrerr	561		
Castroviejo, Klingenthaler	4		
Castroviejo, Meßzirkel	844		
Castroviejo, Mikro-Nadelhalter	404-405,		
.....	410-411, 422-423		
Castroviejo, Mikroschere	111		
Castroviejo-Epker, Meßzirkel	844		
Castroviejo-Fino, Mikro-Nadelhalter	409		
Cerullo, Saugrohr	365		
Chaput, Arterienklemme	183		
Cheattle, Sterilisierzange	956		
Cheron, Tupferzange	235		
Childe, Wundrandpinzette	444		
Chirurgische Nadel	402-403		
Chirurgische Pinzette	143-144, 146-147,		
.....	149-155, 157-160, 446-447		
Chirurgische Schere	20, 22, 24, 26, 28,		
.....	30-37, 42-43, 73-74, 78, 100,		
.....	103, 108-109, 446-447		
Cilienpinzette	169		
Cinelli, Nasenschere	63		
Cinelli, Osteotom	914		
Circumcisionsgerät	793		
Citelli, Ohr-Knochenstanze	874		
Cleveland, Hohlmeißelzange	536		
Cleveland, Knochensplitterzange	546		
Clip-Anlegepinzette	172		
Clip-Anlegezange	175		
Cloward, Valve	315-316		
Cloward, Wirbelkörperspreizer	710		
Cloward, Wundspreizer	315-316		
Coakley, Antrumkürette	925		

Coarctationsklemme613-614
Cobb, Hohlmeißel479
Cobbs, Raspatorium503
Cogswell, Saugrohr373
Collier, Nadelhalter412
Collin, Bauchdeckenhalter324-326, 328-329
Collin, Hammer485
Collin, Nabelschnurklemme842
Collin, Organfasszange184
Collin, Skalpellgriff6
Collin, Tumorfasszange184
Collin, Tupferzange235
Collin, Uterussfasszange823
Collin, Vaginalspekulum798
Collin-Baby, Bauchdeckenhalter324, 327, 328, 329
Collin-Hartmann, Wundhaken294
Columellapinzette925
Cone, Schädelstanze684
Converse, Nasenflügelhäkchen922
Converse, Nasenhaken922
Converse, Nasenschere96
Converse, Rhinoplastikmesser905
Cooley, Anastomosenklemme657-658, 660
Cooley, Aorta-Dilatator665
Cooley, Aortaklemme608-609, 621
Cooley, Atriumhaken289, 582
Cooley, Carotisklemme659
Cooley, Gefäßdilator666
Cooley, Gefäßpinzette656
Cooley, Iliacaklemme658
Cooley, Katheterklemme605
Cooley, Kinder-Gefäßklemme657
Cooley, Mehrzweck-Gefäßklemme647-648, 659-663
Cooley, Rippensperrerr558-559
Cooley, Sauger370-371
Cooley, Seitenvallen573, 578
Cooley-Beck, Anastomosenklemme664
Cooley-Derra, Anastomosenklemme662, 664
Cooper, Unterbindungsnadel437
Cordes, Zangenaufsatz939
Coronarschere82, 85-87, 89
Coryllos, Wundhaken275
Cottle, Applikations-Handgriff916
Cottle, Columellapinzette925
Cottle, Führungshilfe für Osteotome916
Cottle, Hammer485
Cottle, Hautfasspinzette925
Cottle, Knorpelquetsche916
Cottle, Nasenflügelhäkchen923
Cottle, Nasenhäkchen921
Cottle, Nasenhaken923
Cottle, Nasenraspel917
Cottle, Nasenschere95-96
Cottle, Nasenspekulum886-887
Cottle, Osteotom912
Cottle, Periostelevatorium910
Cottle, Raspatorium501
Cottle, Rhinoplastikmesser905
Cottle, Sattelhäkchen923
Cottle, Septumlevatorium909-910
Cottle-Kazanjan, Knochensplitterzange545
Cottle-Neivert, Nasenflügelhäkchen923
Cottle-Walsham, Septumrichtzange924
Coupland, Saugeraufsatz373
Coupland, Saugerhandgriff373
Crafoord, Gefäßklemme203
Crafoord, Präparierklemme203
Crafoord-Sellors, Gefäßklemme203
Crile, Arterienklemme190
Crile, Nadelhalter417
Crile, Nervhäkchen671
Crile-Murray, Nadelhalter413
Crile-Rankin, Arterienklemme191
Crile-Wood, Nadelhalter413, 419, 424, 446-447
Crutchfield, Schädelhalter683
CUSCO, Vaginalspekulum798
Cushing, Anatomische Pinzette142, 145

Cushing, Chirurgische Pinzette154
Cushing, Nervhaken695
Cushing, Sattelhäkchen246
Cushing, Wundhäkchen245
Cushing-Landolt, Hypophysenspekulum733
Cushing-Taylor, Anatomische Pinzette145
Cuzzi, Abortuslöffel841
Czerny, Hakenzange820
Czerny, Mastdarm-Rektum-Spekulum774

D

Dahlgren, Schädelzange684
Dale, Peripheral-Gefäßklemme597
Dammshere97
Dämpfer869
Dandy, Arterienklemme191
Dandy-Mosquito, Arterienklemme191
Dardik, Mehrzweck-Gefäßklemme596
Darm- und Gewebefasszange750-754
Darm-Anastomosenklemme760, 762
Darmklemme754-758, 766-770
Darmquetschklemme759
Darmschere118
Dartigues, Uterussfasszange823
d'Assumpção, Face-Lift Klemme747
Daubenspeck, Scharfer Löffel491
Davidson, Scapulahaken276
Davis, Dura-Doppeldissektor688
Davis, Nervseparator688
Day, Ohrhäkchen878
De Bakey, Anastomosenklemme632
De Bakey, Anlegezange612
De Bakey, Aorta-Aneurysmaklemme619-620
De Bakey, Aortaklemme602, 621, 655
De Bakey, Atraumatische Pinzette147-148
De Bakey, Bulldogklemme591
De Bakey, Gefäßdilator667
De Bakey, Gefäßpinzetten610-611
De Bakey, Gefäßschere82
De Bakey, Kinder-Gefäßklemme643
De Bakey, Ligaturklemme622-623
De Bakey, Mehrzweck-Gefäßklemme618, 636-637, 639-641, 650
De Bakey, Nadelhalter426
De Bakey, Peripheral-Gefäßklemme616
De Bakey, Präparier- und Ligaturklemme615
De Bakey, Präparierschere62
De Bakey, Rahmen565-568
De Bakey, Rippensperrerr565-568
De Bakey, Sauger366
De Bakey, Seitenvallen565-569
De Bakey, Winkelschere134
De Bakey-Adson, Sauger366
De Bakey-Bahnsen, Aneurysmaklemme634
De Bakey-Beck, Anastomosenklemme642
De Bakey-Derra, Mehrzweck-Gefäßklemme652
De Bakey-Diethrich, Bulldogklemme178
De Bakey-Mosquito, Arterienklemme594, 638
De Bakey-Pean, Arterienklemme638
De Bakey-Rankin, Arterienklemme594
De Bakey-Reynolds, Mehrzweck-Gefäßklemme641
De Bakey-Satinsky, Bulldogklemme592
De Bakey-Satinsky, Mehrzweck-Gefäßklemme653
De Martel, Drahtsägen-Einführungsinstrument682
De Martel-Wolfson, Darm-Anastomosenklemme760
De Martel-Wolfson, Klemmenhalterung761
De Martel-Wolfson, Klemmenschießzange760
De Vilbiss, Schädelzange684
Dean, Tonsillenschere93-94
Deaver, Chirurgische Schere33
Deaver, Wundhaken286-288
Deckel, Abfallerimer974
Derrf, Nadelhalter412, 423
Deromatom17
Derra, Anastomosenklemme642

Deschamps, Unterbindungsnadel438-439
Desjardins, Gallenkanalklemme216
Desjardins, Gallensteinzange783
Desmarres, Sattelhäkchen243
Dichtungsring880
Dieffenbach, Bulldogklemme176
Diethrich, Aortaklemme595
Diethrich, Bulldogklemme178
Diethrich, Gefäßschere81, 84, 89
Diethrich-Salyer, Präparierschere92
Dilatationssonde826
Dingmann, Knorpelfasszange525
Dissektions- u. Zahnfleischschere75
Dissektionsschere77
Doppeldissektor513
Doppelkürette497, 925
Doppelraspatorium508
Dose965
Douglas, Cilienpinzette169
Doyen, Darmklemme754, 766
Doyen, Hammer484
Doyen, Hohlsonde347
Doyen, Myomheber822
Doyen, Rippenraspatorium507
Doyen, Scheidenhalter810
Doyen, Uterusschere44
Doyen, Vaginalspekulum806
Doyen, Wundhaken273
Doyen-Baby, Darmklemme755, 766
Doyen-Stille, Wundhaken269
Drahtbiegezüngchen856
Drahtsäge682
Drahtsägen-Einführungsinstrument682
Drahtsägen-Handgriff682
Drahtschere121-122, 135
Drahtvalven335
Drainagedurchführzange557
Dreiring-Spritze382
Dreiwegehahn380
Dubost, Rahmen570
Dubost, Seitenvallen570, 571
Dubost, Thoraxsperrerr570
Dunhill, Arterienklemme189
Duplay, Hakenzange817
Duradisektor688-689
Dura-Doppeldissektor686-688
Durahaken696-697
Durante, Chirurgische Pinzette157
Duraschere90
Durchflusshahn380
Duval, Darm- und Gewebefasszange753-754

E

Echlin, Hohlmeißelzange541
Eicken-Killian, Spülkanüle926
Einführungszüngchen858
Einmalskalpell13-14
Einsteckkonus881
Eiselsberg, Ligaturschere120
Elevatorium510, 512-513
Emmett, Fistelhaken824
Endospekulum811
Enukleationsschere110
Episiotomieschere97
Ersatzbacken486-488
Ersatzdorn683
Ersatzflasche880
Ersatzglas949
Ersatzklinge17
Ersatzknopf868
Ersatzlampe391
Ersatzmesser453, 792
Ersatznadel174
Ersatzzylinder381-384
Esmarch, Gipsmesser455
Esmarch, Gipschere451
Eves, Tonsillenschürer936

F			
Face-Lift Häkchen	745		
Face-Lift Klemme	185, 747		
Face-Lift Schere	57, 75, 119, 131, 747-748		
Fadenfänger	443, 671		
Fadenführer	706		
Fadenführungszange	787		
Fadengabel	443, 705		
Fadenklemme	185-186		
Fadenschere	119		
Fahlbusch, Mikroschere	700		
Farabeuf, Knochenhaltezege	530		
Farabeuf, Raspatorium	502		
Farabeuf, Wundhaken	295		
Farabeuf-Collin, Raspatorium	502		
Farrell, Watteträger	352		
Farrior, Ohrspekulum	865		
Fasspinzette	158, 702-703		
Fasziotomiespatel	669		
Faulkner, Doppelkürette	925		
Faure, Peritoneumklemme	225		
Faure, Probeexzisionszange	826		
Favaloro, Gefäßschere	88, 90		
Feder	322		
Fehland, Rektum-Anastomosenklemme	772		
Feilchenfeld, Splitterpinzette	167		
Fergusson, Knochenhaltezege	527		
Fergusson, Saugrohr	361		
Ferris-Smith-Kerrison, Keilbeinstanze	902		
Filiform, Gleitsonde	791		
Finocchio (modif.), Rippensperrerr	561		
Finocchio, Baby, Rippensperrerr	564		
Finocchio, Infant, Rippensperrerr	559		
Finocchio, Nadelhalter	415, 427		
Finocchio, Präparierklemme	213		
Finocchio, Rippensperrerr	560, 564		
Finsen, Wundspreizer	298		
Finsen-Martin, Wundspreizer	298		
Fisch, Mikro-Dissektor	862		
Fisher, Tonsillennmesser	933		
Fistelhaken	824		
Fistelsonde	347		
Fixiervorrichtung	690, 691		
Flachmeißel	465-468, 480		
Flügelmutter	775		
Fomon, Meißel	913		
Fomon, Nasenflügelhäkchen	921-922		
Fomon, Nasenraspel	918, 920		
Fomon, Nasenschere	63, 95		
Fomon, Rhinoplastikmesser	905		
Foregger, Kaltlicht-Laryngoskopiebesteck	394		
Foregger, Kaltlicht-Laryngoskopspatel	395		
Foregger, Laryngoskopiebesteck	390		
Foregger, Laryngoskopspatel	390, 391		
Förster, Schwammzange	236-237		
Foster-Gillies, Nadelhalter	432		
Fox, Lupuskürette	744		
Fraenkel, Zangenaufsatz	938		
Frazier, Durahaken	697		
Frazier, Saugkanüle	360-361		
Freeman, Face-Lift-Schere	748		
Freeman-Kaye, Face-Lift-Schere	748		
Freer, Mukosahäkchen	922		
Freer, Mukosamesser	906		
Freer, Septumlevatorium	907-908		
Freer, Septum-Hohlmeißel	911		
Freer, Septummeißel	911		
Freer, Septummesser	906		
Fremdkörperhebel	872, 877		
Fremdkörperpinzette	168		
Fremdkörperzängchen	872		
Fremdkörperzange	794		
French, Stimmgabel	866		
Friedmann, Hohlmeißelzange	536		
Fritsch, Wundhaken	272		
Frosch, Knochenhaltezege	527		
Frykholm, Hohlmeißelzange	542		
Führungshilfe für Osteotome	916		
Führungshohlsonde	440-443		
Fuller, Einführungsängchen	858		
Fuss	868		
Fusshalter	868		
G			
Gabelschlüssel	668		
Galeahaken	686		
Gallaher, Antrumraspel	917		
Gallenkanaldilatator	781		
Gallenkanalklemme	213, 216		
Gallenstein-Löffel	784		
Gallensteinzange	782-783		
Gardner, Meißel	464		
Gaumenraspatorium	907, 932		
Gaumenspaltendissektor	932		
Gaumenspaltelevatorium	932		
Gaumenspaltenhaken	932		
Gaumenspaltenchere	72, 119		
Geburtslöffel	840		
Geburtszange	838-839		
Gefäßclip	172, 179		
Gefäß-Dilatationspinzette	162		
Gefäßdilatator	666-667		
Gefäßdissektor	670		
Gefäßkanüle	379		
Gefäßklemme	203, 627		
Gefäßmesszirkel	604		
Gefäßpinzette	610-611, 656		
Gefäßschere	80-84, 88-90		
Gefäß-Spülkanüle	378		
Geknöpfte Ansatz	882		
Gellhorn, Probeexzisionszange	826		
Gelpi, Wundspreizer	323		
Gemini, Präparierklemme	207		
Gerald, Anatomische Pinzette	142		
Gerald, Atraumatische Pinzette	148		
Gerald, Chirurgische Pinzette	143, 154		
Gesichtsschutz	952		
Gewebebrille	704		
Gewicht zum Vaginalsekulum	808-809		
Gewichte	869		
Gewindeansatz	882		
Giertz-Stille, Rippenschere	555		
Gigli, Drahtsäge	682		
Gigli, Drahtsägen-Handgriff	682		
Gillies, Chirurgische Pinzette	143, 152		
Gillies, Hauthäkchen	745		
Gillies, Nadelhalter	417, 432		
Gillies-Mini, Nadelhalter	432		
Gil-Vernet, Sattelhäkchen	247		
Gipsabreisszange	457		
Gipsmesser	455		
Gipsschere	451-454		
Gipsspreizer	456		
Glabellaraspel	918		
Glas-Reinigungsbürste	973		
Gleitsonde	791		
Glover, Anastomosenklemme	631		
Glover, Bulldogklemme	592, 612		
Glover, Mehrzweck-Gefäßklemme	640		
Gluck, Rippenschere	554		
Goelet, Wundhaken	297		
Goldman-Fox, Zahnfleischschere	99		
Goldmann-Fox, Ligaturschere	99		
Goldsmith (Thudichum), Nasenspekulum	884		
Good, Tonsillenschere	93		
Goodell, Uterusdilatator	811		
Gorney, Face-Lift Schere	57, 131, 748		
Gosset, Bauchdeckenhalter	330-331		
Gosset-Baby, Bauchdeckenhalter	330		
Graefe, Irisschere	104		
Graefe, Mikrohäkchen	240		
Graham, Durahaken	696		
Graig, Septumzangen	891		
Grant, Aortaklemme	607		
Grave, Vaginalsekulum	799		
Green-Armytage, Klemmzange	840		
Greene, Uteruskürette	834		
Gregory, Carotis-Bulldogklemme	593		
Gregory, Face-Lift-Schere	747		
Gregory, Nadelhalter	420		
Gregory, Profundaklemme	598		
Gregory, soft, Carotis-Bulldogklemme	593		
Griff für Kehlkopfspiegel	941		
Griff zum Vaginalsekulum	807, 808		
Groningen, Nervhaken	695		
Gross, Ohrlöfel und Häkchen	877		
Gross-Maier, Korn- u. Tupferzange	234, 446-447		
Grünwald (Jansen), Nasentamponpinzette	890		
Grünwald, Halbgebläse	880		
Grünwald, Nasentamponpinzette	890		
Grünwald, Ohrpinzette	871		
Guedel-Negus, Laryngoskopiebesteck	388		
Guedel-Negus, Laryngoskopspatel	388		
Guilen, Saugraspatorium	926		
Gummibirne	881		
Gummichtung	882		
Gunnar-Hey, Rollenklemme	230		
Guthrie, Hauthäkchen	241		
Guttmann, Vaginalsekulum	799		
Guyon, Harnröhrenbougie	790		
Guyon, Nierenstielklemme	214-215		
H			
Haberer, Bauchspatel	344		
Hach, Fasziotomiespatel	669		
Haemorrhoidal-Ligator	776		
Haemorrhoiden-Fasszange	777		
Haight, Rippensperrerr	562		
Hajek, Keilbeinstanze	901		
Hajek-Kofler, Keilbeinstanze	901		
Hakenhalterung	343		
Hakensystem	343		
Hakenvalve	341		
Hakenzange	817-820		
Halbgebläse	880		
Halle, Scharfe Löffel	495		
Halle, Septumlevatorium	907		
Halsey, Nadelhalter	412, 424		
Halsted-Mosquito, Arterienklemme	186-187, 446-447		
Haltearm	343, 692-693		
Halteschraube	470		
Hammer	484-489		
Hammerkopfzängchen	857		
Handdermatom	17		
Handgriff	351, 367		
Handwaschbürste	948		
Hank, Uterusdilatator	815		
Harken, Aurikellklemme	629		
Harnröhrenbougie	790		
Harnröhrenolive	380		
Harrington, Wundhaken	285		
Hartmann, Arterienklemme	186		
Hartmann, Hohlmeißelzange	537		
Hartmann, Nasenpolypenzange	890		
Hartmann, Ohrhäkchen	877		
Hartmann, Ohrkatheter	870		
Hartmann, Ohrpolypenzange	872-873		
Hartmann, Ohrspekula, Satz	864		
Hartmann, Ohrspekulum	864		
Hartmann, Scharfe Nasenzange	898		
Hartmann, Stimmgabel	866-868		
Hartmann, Tonsillenzange	937		
Hartmann, Wundspreizer	311		
Hartmann-Halle, Nasenspekulum	884		
Hartmann-Herzfeld, Ohrpolypenzange	873		
Hartmann-Hoffman, Ohrpolypenzange	873		
Hartmann-Wullstein, Ohrpolypenzange	873		
Hautfasspinzette	925		
Hauthäkchen	240-241, 745		
Hauttrephine	745		
Hayes, Rektum-Anastomosenklemme	771		
Heaney, Hysterektomieklammer	219		
Heaney, Nadelhalter	414, 426		
Hegar, Nadelhalter	429		
Hegar, Uterusdilatator	812-814		
Hegar, Uterusdilatatoren, Satz	812		
Hegar-Baumgartner, Nadelhalter	413, 424		
Hegar-Vascular, Nadelhalter	429		

Hegenbarth, Wundklammerpinzette.....444
 Heifetz, Fasspinzette702
 Heifetz, Spatel694
 Heiming, Nierensteinzange.....780
 Heiss, Präparierklemme201
 Henckel-Tilley, Nasenzange870
 Henke, Tonsillenelevatorium934
 Henley, Mittelvalve312
 Henley, Wundspreizer312
 Henly, Katheterklemme604
 Hennig, Gipsspreizer456
 Heparinnadel376, 379
 Hepp-Scheidel, Mikro-Nadelhalter419
 Hepp-Scheidel, Tubenfasspinzette159
 Heymann, Nasenschere96
 Heywood-Smith, Uteruspolypenzange821
 Hibbs, Flachmeißel480
 Hibbs, Hohlmeißel481
 Hibbs, Osteotom480-481
 Hirnmesser3
 Hirnspatel690
 Hohenfellner, Präparierschere61
 Hohlmeißel.....464-467, 469, 472-473,
478-479, 481, 913
 Hohlmeißelklinge470
 Hohlmeißelzange536-544
 Hohlsonde347
 Hohman, mini, Knochenheber514
 Hohmann, Knochenheber515-517
 Hoke, Osteotom480
 Hopkins, Gipsmesser455
 Hösel, Wundhaken270
 House, Mikro-Kürette.....863
 House, Mikro-Messsonde863
 House, Saugrohr369
 House-Dieter, Hammerkopfzängchen.....857
 Howarth, Septumlevatorium909
 Huber, Universalgriff830
 Humby, Dermatome17
 Humby, Ersatzklinge17
 Hunt, Fasspinzette703
 Hunter, Splitterpinzette168
 Hurd, Tonsillenelevator/Retraktor933
 Husfeldt, Peripheral-Gefäßklemme.....603
 Hypophysenspekulum733
 Hypophysenzange731-732
 Hysterektomieklammer219-220, 222-223
 Hysterektomieschere132-133

I
 Iliacklamme658
 Induktiv-Akkueinsatz399, 400
 Induktiv-Akkuhandgriff392, 394, 396, 399
 Induktiv-Ladegerät400
 Infektionsschutzbrille952
 Inge, Knochenspreizer710
 Inge, Wirbelkörperspreizer710-711
 Innendose958
 Instrumentenkasten812, 964
 Insufflationskanüle378
 Insulinspritze382
 Intimaspatel670
 Inzisionsschere33
 Iowa, Hakenzange819
 Irtischer103-107
 Israel, Wundhaken257
 Iterson, Trachealhaken741
 IUP-Fasszange830
 Ives-Fansler, Anuskop774

J
 Jaboma, Anatomische Pinzette147
 Jaboma, Chirurgische Pinzette.....147
 Jaboma, Mikroschere117
 Jaboma, Nadelhalter419
 Jackson, Trachealhaken741
 Jackson, Vaginalsepekulum800
 Jacobs, Hakenzange819
 Jacobson, Knopfsonde708
 Jacobson, Mikro-Gefäßmesser.....705

Jacobson, Mikro-Nadelhalter701
 Jacobson, Mikroschere114, 698
 Jacobson, Scharfer Löffel496
 Jameson, Präparierschere.....77
 Jamieson, Saugrohr372
 Jamison, Nadelhalter415
 Janet, Ersatzzylinder384
 Janet, Wund- u. Blasenspritze384
 Jansen, Hohlmeißelzange.....537
 Jansen, Ohrlöffel877
 Jansen, Ohrpinzette871
 Jansen, Raspatorium500
 Jansen, Wundspreizer300
 Javid, Carotis-Shuntklemme599
 Jeweler mod., Gefäß-Dilatationspinzette162
 Jeweler mod., Mikropinzette162
 Johns-Hopkins, Bulldogklemme177
 Johnson, Nadelhalter416
 Joll, Thyreoid- und Vulva-Spreizer323
 Jones, Tuchklemme226
 Jones-Martin, Tuchklemme.....226
 Joseph, Chirurgische Schere.....73,74
 Joseph, Knochenfeile.....917
 Joseph, Mukosahäkchen921-922
 Joseph, Nasensäge915
 Joseph, Periostelevatorium910
 Joseph, Präparierschere73-74
 Joseph, Rhinoplastikmesser905
 Joseph, Septumlevatorium.....907
 Joseph-Masing, Periostelevatorium910
 Jud-Allis, Darm- und Gewebefasszange.....751
 Judd-Masson, Blasenwundsperrler788
 Jurasz, Kehlkopfpolypenzange942

K
 Kabierske, Ersatzflasche880
 Kabierske, Ohrkanüle880
 Kabierske, Pulverbläser.....880
 Kabierske, Ventilball880
 Kader, Bauchspatel293
 Kahre-Williger, Raspatorium505
 Kallmorgen, Scheidenhalter805
 Kallmorgen, Vaginalsepekulum805
 Kalt, Nadelhalter408
 Kaltlichtaufsatz775
 Kaltlicht-Batteriehandgriff.....392, 394,
396, 398
 Kaltlicht-Induktiv-Akkuhandgriff399
 Kaltlicht-Laryngoskopiebesteck.....392, 394, 396
 Kaltlicht-Laryngoskopspatel.....392-393,
395-397
 Kanülennadel376
 Kappenzange960
 Kapselasszange786-787
 Katheteransatz380
 Katheteranschlussstutzen.....380
 Kathetereinführungszange.....386
 Katheterklemme604-605
 Katsch, Komedonenquetscher746
 Kaye, Face-Lift Häkchen745
 Kaye, Face-Lift Schere.....57, 119, 747
 Kaye, Skalpellgriff9
 Kaye-Millard, Wundhäkchen248
 Kehlkopfpolypenzange942
 Kehlkopfrohr937, 938, 939
 Kehlkopfspiegel940-941
 Keilbeinstanze901-903
 Kellenmesser844
 Kelly, Arterienklemme.....189
 Kelly, Chirurgische Schere.....42-43
 Kelly, Präparierklemme217
 Kelly, Sphinkteroskop776
 Kelly, Uteruspolypenzange821
 Kelly, Wundhaken.....268, 291
 Kelly-Rankin, Arterienklemme190
 Kern, Knochenhalte-zange.....529
 Kerrison, Antrumstanze904
 Kerrison, Laminektomiestanze712-723
 Kevorkian, Biopsiekürette.....825
 Kevorkian, Probeexzisionszange829

Key, Raspatorium503
 Keyes, Hauttrephine745
 Kielland, Geburtszange839
 Kielland-Luikart, Geburtszange.....839
 Killian, Nasenspekulum885
 Killian, Septumlevatorium909
 Killian, Septum-Hohlmeißel911
 Killian-Claus, Septum-Hohlmeißel911
 Kilner, Hauthäkchen745
 Kilner, Nadelhalter423
 Kilner, Nasenflügelhäkchen.....922
 Kilner, Präparierschere.....76
 Kinderdarmklemme758
 Kinder-Gefäßklemme643-646, 649,
657, 673-676
 Kirschner, Bauchdeckenhalter337-338
 Kirschner, Führungshohlsonde.....441-442
 Kirschner, Rahmen337-339
 Kirschner, Rahmenhaken337-339
 Klammerzange685
 Klapp, Wundhaken249
 Klappenhaken583
 Klemmenhalterung761
 Klemmschließzange760
 Klemmschloß762
 Klemmzange840
 Klingenspreizer u. -Halter4
 Klingenthalter4
 KLING-EX, Skalpellklingentferner10
 Kniehaken519
 Knight, Septumzangen.....891
 Knochenfasszange.....528
 Knochenfeile509-511, 917
 Knochenhäkchen.....240
 Knochenhalte-zange525-527, 529-535
 Knochenheber514-519
 Knochenmeißel464
 Knochenraspel482
 Knochenschere554
 Knochensplitterzange545-549
 Knochenspreizer710
 Knochenrepositionszange526
 Knopfsonde346, 708
 Knorpelfasszange525-526
 Knorpelquetsche916
 Knorpelzange525
 Knowles, Verbandschere450
 Knutson, Urethrographieinstrument793
 Knutson-Koch, Konus793
 Kocher (Ochsner), Arterienklemme.....198-199
 Kocher, Arterienklemme.....194, 446-447
 Kocher, Darmklemme757-758, 768-769
 Kocher, Kropfsonde742
 Kocher, Wundhaken253, 262, 266, 273
 Kocher-Langenbeck, Wundhaken263-264
 Kocher-Nippon, Arterienklemme194
 Koenig, Raspatorium500
 Kogan, Endospekulum811
 Kölner Sparklammer685
 Komedonenquetscher746
 König, Führungshohlsonde442
 König, Stimmgabel869
 Konisationsmesser824
 Konischer Ansatz882
 Konus793
 Koos, Mikro-Gefäßmesser705
 Kopfhautklammer685
 Korn- u. Tupferzange232-234, 446-447
 Koronarfettspreizer585
 Körte, Wundhaken256
 Krause, Polypenschnürer.....870, 888
 Krause, Zangenaufsatz939
 Krause-Voss, Polypenschnürer870, 888
 Krayenbühl, Nerv- und Gefäßhäkchen709
 Krenkel, Gaumenraspatorium907
 Kressner, Septumzange924
 Kristeller, Scheidenhalter801-804
 Kristeller, Vaginalsepekulum801-804
 Kronecker, Unterbindungsnadel437
 Kropffasszange742

Kropfsonde742
 Kryptonlampe398
 Kugelgelenk-Kloben.....692, 693
 Kunststoffspitze350
 Kupplungskopf.....691-693
 Kupplungsstück834

L

La Grange, Zahnfleischschere101
 Laborde, Trachealdilatator740
 Ladekonus776
 Lagerungsetui für Laryngoskope391
 Lahey, Gallenkanalklemme213
 Lahey, Kropffasszange742
 Lahey, Wundhaken261
 Lambert-Kay, Anastomosenklemme632
 Lambert-Kay, Mehrzweck-Gefäßklemme654
 Lambotte, Osteotom475-476
 Lambotte, Raspatorium508
 Lambotte-Mini, Osteotom474
 Laminektomiesperrerr340
 Laminektomiestanze712-723
 Laminektomiezangen724-731
 Landolt, Raspatorium500
 Landolt, Saugrohr365
 Landolt, Tumorfasszange732
 Lane, Knochenhaltezeuge533
 Lane, Magen und Darm-Zwillings-
 klemmen763-764
 Lane, Tuchklemme228
 Lange, Nasenflügelhäkchen921
 Lange, Zangenaufsatz938
 Lange-Hohmann, Knochenheber517
 Langenbeck, Elevatorium512
 Langenbeck, Knochenhaltezeuge527
 Langenbeck, Nadelhalter434
 Langenbeck, Ohrkürette876
 Langenbeck, Raspatorium500
 Langenbeck, Resektionsmesser15
 Langenbeck, Wundhaken258-260
 Langenbeck-Green, Wundhaken260
 Langenbeck-Mini, Wundhäkchen243
 Lappenmesser859
 Laryngoskopiebesteck387-390
 Laryngoskopspatel387-391
 Lawrence, Präparierklemme218
 Lazar, Mikro-Knüpfpinzette167
 Leberhaken291
 Leberklemme626
 Leberpunktionskanüle379
 Lebsche, Sternummeißel556
 Lees, Bronchusklemme630
 Leksell-Stille, Hohlmeißelzange542
 Leland-Jones, Peripher-Gefäßklemme617
 Lempert, Hohlmeißelzange537
 Lempert, Mikro-Ohr Raspatorium879
 Lempert, Ohröffel879
 Leriche, Arterienklemme188
 Lewin, Knochenhaltezeuge526
 Lewis, Nasenraspel918
 Lexer, Hohlmeißel473
 Lexer, Osteotom473
 Lexer, Präparierschere58, 60, 127
 Lexer, Spongiosameißel471
 Lexer-Baby, Präparierschere64
 Lexer-Fino, Präparierschere65
 Lexer-Mini, Hohlmeißel472
 Lexer-Mini, Osteotom472
 Leyla, Fixiervorrichtung691
 Leyla, Haltearm692, 693
 Leyla, Hirnspatel690
 Leyla, Kugelgelenk-Kloben692, 693
 Leyla, Kupplungskopf691-693
 Leyla, Spannhalter691-692
 Lichtenberg, Nadelhalter418, 434
 Ligatur-Gummiringe776
 Ligaturklemme622-623
 Ligaturschere99, 119-120, 124-125
 Lillehei-Potts, Präparierschere123
 Lister, Sinusklemme233

Lister, Verbandschere450, 454
 Liston, Knochensplitterzange545
 Liston-Key, Knochensplitterzange549
 Littauer, Cilienpinzette169
 Littauer, Ligaturschere120
 Little, Wundhaken261
 Lockhart-Mummery, Fistelsonde347
 Locklin, Zahnfleischschere102
 Lockwood, Darm- und Gewebefasszange751
 Logan, Wundspreizer299
 Lorenz, Verbandschere450
 Lorna, Tuchklemme227
 Lovelace, Arterienklemme191
 Lovelace, Lungenfasszange590
 Lower, Präparierklemme213
 Lubet-Barbon, Nasentamponzange890
 Lucae, Hammer485
 Lucae, Ohrhäkchen877
 Lucae, Parazentesenadel878
 Lucae, Stimmgabel868
 Luer, Hohlmeißelzange539
 Luer, Saugrohr360, 364
 Luer, Trachealhaken741
 Luer-Schraubadapter668
 Luftdusche881
 Lukens, Thymushaken741
 Lumbalpunktionskanüle377
 Lungenfasszange590
 Lungenspatel586
 Luniatschek, Tamponstopfer934
 Lupuskürette744
 Lupusöffel744
 Lupusschaber744

M

M. G. Hospital, Nadelhalter414
 Magen und Darm-Zwillingsklemmen763-764
 Magill, Kathetereinführzange386
 Maltz, Nasenraspel917, 919
 Manometer zum Salpingograph835
 Marquard, Hohlmeißelzange540
 Martel-Rees, Face-Lift Klemme185
 Martin Aquajet, Wasserstrahl-
 Reinigungspistole968
 Martin, Abfallzange974
 Martin, Bauchspatel344
 Martin, Beckenzirkel838
 Martin, Bürstenspender948
 Martin, Gabelschlüssel668
 Martin, Gefäßmesszirkel604
 Martin, Gipsmesser455
 Martin, Knorpelfasszange526
 Martin, Korn- u. Tupferzange233
 Martin, Luer-Schraubadapter668
 Martin, Martin-Arm-System '99342
 Martin, Nadelhalter427
 Martin, Nasenspekulum885
 Martin, Optikhalterung342
 Martin, Peripher-Gefäßklemme600
 Martin, Schraubaufsatz für Venen668
 Martin, Schraubolive668
 Martin, Stimmgabel867
 Martin, Tunnelierer-Griff668
 Martin, Tunnelierschiff668
 Martin, Tunnelier-Set668
 Martin, Universal-Befestigungskloben342, 343
 Martin, Wundhaken254, 274
 Martin, Wundspreizer321
 Martin-Alloy, Stimmgabel867
 Martin-Aquajet, Reinigungsaufsatz972-973
 Martin-Arm-System '99342
 Martin-Aseptic, Handwaschbürste948
 Martin-Cushing, Raspatorium499
 Martin-Fuchsig, Präparierklemme192
 Martin-Hoen, Raspatorium498
 Martin, Nadelhalter430-431
 Martin-Langenbeck, Elevatorium512
 Martin-Langenbeck, Raspatorium498
 Martin-Rochard, Hakenhalterung343
 Martin-Rochard, Hakensystem343

Martin-Rochard, Haltearm343
 Martin-Rochard, Querstab343
 Martin-Rochard, Schiebekloben343
 Martin-Rochard, Wundhaken343
 Masing, Periostelevatorium910
 Masson, Nadelhalter415, 426
 Mastdarm-Rektum-Spekulum774
 Mathieu, Fremdkörperzange794
 Mathieu, Nadelhalter417-418, 432-433
 Mathieu, Wundhaken297
 Mayfield, Hohlmeißelzange540
 Mayo, Chirurgische Pinzette34-35, 158
 Mayo, Präparierschere34-35
 Mayo, Sterilisierklammer960
 Mayo-Blake, Gallensteinzange782
 Mayo-Harrington, Präparierschere39
 Mayo-Hegar, Nadelhalter414, 425
 Mayo-Lexer TCC-BlackLine, Präparierschere59
 Mayo-Lexer, Präparierschere127
 Mayo-Lexer-Aquila, Präparierschere59
 Mayo-Noble, Präparierschere39
 Mayo-Robson, Darmklemme756, 767
 Mayo-Stille, Chirurgische Schere36-37
 Mayo-Stille, Präparierschere36-38
 McDonald, Doppeldissektor513
 McGee, Drahtbiegezüngchen856
 McGee, Mikro-Ohrhäkchen861
 McGinvey, Haemorrhoiden-Fasszange777
 McIndoe, Anatomische Pinzette140, 143
 McIndoe, Neurochirurgische Schere92
 McIntosh, Kaltlicht-Laryngoskopiebesteck392
 McIntosh, Kaltlicht-Laryngoskopspatel392-393
 McIntosh, Laryngoskopiebesteck389
 McIntosh, Laryngoskopspatel389
 McKenty, Septumlevatorium907-908
 McKenzie, Klammerzange685
 McQuigg-Mixer, Präparierklemme212
 Mead, Hammer486
 Mead, Hohlmeißelzange537
 Meatotom794
 Meeker, Präparierklemme218
 Mehrzweck-Gefäßklemme596, 618,
635-637, 639-642,
647-648, 650-654, 659-664
 Mehrzweckschale963
 Meißel464, 913
 Meißelklinge470
 Menghini, Leberpunktionskanüle379
 Meniskotom520
 Meniskusmesser520
 Messbecher962
 Messlehre794
 Meßzirkel844
 Metallkatheter für Frauen791
 Metallolive882
 Metallstößel483
 Metzenbaum, Nadelhalter413
 Metzenbaum, Präparierschere47-48, 50-54,
56, 67, 70, 446-447
 Metzenbaum-Aquila, Präparierschere49, 55
 Metzenbaum-Aquila-Fino,
 Präparierschere67, 70
 Metzenbaum-Fino,
 Präparierschere66-71, 128, 130
 Metzenbaum-Lahey, Präparierschere128
 Metzenbaum-Nelson, Präparierschere52-54
 Metzenbaum-TCC-BlackLine,
 Präparierschere49, 55
 Metzenbaum-TCC-BlackLine-Fino,
 Präparierschere126
 Metzenbaum-Thorek, Präparierschere127
 Meyerding, Wundhäkchen244
 Michel, Kehlkopfspiegel941
 Michel, Wundklammern445
 Michel, Wundklammerpinzette444
 Michel, Wundklammerzange444
 Microvascular, Nadelhalter430
 Middeldorp, Wundhaken267, 271
 Middleton-Jansen, Septumzange899
 Mikro-Adson, Anatomische Pinzette155

Mikro-Adson, Arterienklemme185
Mikro-Adson, Chirurgische Pinzette155
Mikro-Dissektor349, 705, 707, 862
Mikro-Friedman, Hohlmeißelzange538
Mikro-Gefäßhäkchen242
Mikro-Gefäßmesser705
Mikro-Gewichts-Pinzette162, 164
Mikrohäkchen240, 708
Mikro-Hegemann, Coronarschere82
Mikro-Knüpfpinzette167
Mikro-Kürette708, 863
Mikro-Messsonde863
Mikro-Mosquito, Arterienklemme188
Mikro-Nadelhalter404-411, 418-423, 701
Mikro-Ohr Raspatorium879
Mikro-Ohrhäkchen860-862
Mikro-Ohrnadel860-861
Mikro-Ohrspatorium862
Mikro-Ohrscherchen854-855
Mikro-Ohrzängchen848-853
Mikro-Phlebextraktor349
Mikropinzette141, 153, 161-163, 165, 702
Mikro-Präparierschere116, 699
Mikro-Raspatorium706
Mikro-Ringpinzette162-163, 165
Mikroschere79, 111-117, 698-700
Mikroskopierpinzette168
Mikro-Venenschere116
Mikulicz, Leberhaken291
Mikulicz, Peritoneumklemme224-225
Mikulicz, Wundhaken290
Mikulicz-Baby, Peritoneumklemme224
Miller, Kaltlicht-Laryngoskopiebesteck396
Miller, Kaltlicht-Laryngoskopspatel396-397
Miller, Knochenfeile511
Miller, Laryngoskopiebesteck387
Miller, Laryngoskopspatel387
Miller-Baby, Laryngoskopiebesteck387
Miller-Colburn, Knochenfeile510-511
Millesi, Mikroschere698
Milligan, Nervseparator688
Milligan, Wundspreizer311
Millin, Blasenhalssperrerr788
Millin, Blasenwundsperrerr789
Millin, Fadenführungszange787
Millin, Kapselasszange786-787
Mini Glover, Präparierklemme181
Mini-Adson, Chirurgische Pinzette155
Mini-Gefäßclip175
Mini-Gemini, Präparierklemme207
Mini-McGee, Mikro-Ohrzängchen849
Mini-Phlebextraktor349
Mittelteil mit Ball880
Mittelvalve312, 322, 325-327,
.....330-336, 775, 789
Mixer, Gallensteinzange783
Mixer, Präparierklemme210-212
Mixer-Baby, Präparierklemme185, 201, 209
Mixer-O'Shaughnessy, Präparierklemme210
Mock, Heparinnadel376, 379
Mod. Bonn, Irisschere104
Mod. Martin, Bruchsonde441
Mod. Martin, Gesichtsschutz952
Mod. Martin, Kappenzange960
Mod. München, Biopsiekürette825
Mod. USA, Nabelschnurschere98
Mod. Wien, Nasenspekulum886
Modell USA, Scharfer Löffel494-495
Modell Wien, Fadenfänger443
Mogen, Beschneidungsinstrument793
Moldenhauer, Fremdkörperhebel877
Mollison, Wundspreizer308
Molt, Doppelkürette497
Molt, Scharfe Kürette497
Morris-De Bakey, Aortaklemme633
Morse, Sternumspreizer563
Morse-Favaloro, Rippenspererr562
Moynihan, Hysterektomieklamme222
Muehling, Raspatorium502
Mueller, Gefäßclip179

Mukosahäkchen921-922
Mukosamesser906
Müller, Approximator172-173
Museum, Hakenzange819
Myomheber822
Myommesser822
Myrtenblattsode346

N

Nabatoff, Kunststoffspitze350
Nabatoff, Olive350
Nabatoff, T-Griff350
Nabatoff, Varizenbesteck350
Nabatoff, Zugseil350
Nabelschnurklemme842
Nabelschnurschere98
Nadelaufsatz436
Nadeldose961-963
Nadelstiel957
Nadelhalter408, 411-420, 422-434,
.....436, 446-447
Nadelschale959
Nagel, Mikroschere700
Nägele, Geburtszange838
Nageleckenzange951
Nagelfeile951
Nagelhautschere951
Nagelhautzange951
Nagelschere950
Nagelzange950
Nasenflügelhäkchen921-923
Nasenhäkchen921
Nasenhaken921-923
Nasenmeißel914
Nasenolive881
Nasenpolypenzange890
Nasenraspel917-920
Nasensäge915
Nasenschere63, 95-96
Nasenspekulum884-887
Nasentamponpinzette890
Nasentamponzange890
Nasenzange870
Neff, Meniskusmesser520
Negus, Arterienklemme218
Neivert, Nadelhalter412
Neivert, Nasenflügelhäkchen923
Neivert-Anderson, Osteotom914
Nelaton, Hohlsonde347
Nelson, Chirurgische Pinzette159
Nelson, Trokar358
Neonatal-Gefäßklemme675, 677
Nerv- und Gefäßhäkchen709
Nerv-Approximator174
Nervhäkchen671
Nervhaken695
Nerv-Präparierschere56
Nervseparator687-688
Neuro, Stimmgabel869
Neurochirurgische Schere90, 92
Nieren u.- Pankreas-Klemme627
Nierenschale965
Nierenschalen-Deckel965
Nierensteinzange780
Nierenstielklemme214-215
Norfolk-Norwich, Wundspreizer302
Northbent, Fadenschere119
Noto, Uteruspolypenzange821
Novak, Saugkürette825
Nuboer, Saugrohr372

O

Obturator926
Ochsner, Aortaklemme595
O'Connor, Hauthäkchen241
Oehler, Chirurgische Pinzette146
Ogura, Hautfasspinzette925
Ohrhäkchen877-878
Ohrkanüle880
Ohrkatheter870

Ohr-Knochenstanze874-875
Ohrkürette876
Ohrlöffel877, 879
Ohrlöffel und Häkchen877
Ohrlive881
Ohrpinzette871
Ohrpolypenzange872-873
Ohrschlinge877
Ohrsonde346
Ohrspekula, Satz864-865
Ohrspekulaständer865
Ohrspekulum864-865
Ohrspritze882-883
Oldberg, Hypophysenzange732
Olive348, 350
Olivecrona, Dura-Doppeldissektor686-687
Olivecrona, Trigeminusschere92
Olivecrona-Tönnis, Klammerzange685
Ollier, Wundhaken255
Olsen-Hegar, Nadelhalter417, 431
Optikhalterung342
Organfasszange183-184, 765
O'Shaughnessy, Präparierklemme210
Osteotom465, 468-469, 472-477,
.....480-481, 912-914
Osteotomklinge470
O'Sullivan-O'Connor, Bauchdeckenhalter336
Oszillierende Gipsäge458
Otis, Ersatzmesser792
Otis, Urethrotom792
Overholt-Baby, Präparierklemme190
Overholt-Fino, Präparierklemme205-206
Overholt-Geissendörfer, Präparierklemme204
Overholt-Martin, Präparierklemme200
Overholt-Mini, Präparierklemme206
Overholt-Mixer, Präparierklemme201

P

Papavero-Caspar, Hypophysenspekulum733
Parametriumklemme221
Parametriumschere132-133
Parazentesenadel878
Parker, Wundhaken296
Parker-Langenbeck, Wundhaken297
Parker-Mott, Wundhaken296
Parkes, Osteotom914
Partsch, Flachmeißel466
Partsch, Hammer486
Partsch, Hohlmeißel466
Payr, Darmquetschklemme759
Payr, Führungshohlsonde443
Payr-Baby, Darmquetschklemme759
Pean (Rochester), Arterienklemme196-197
Pean, Arterienklemme182, 193, 446-447
Pean-Nippon, Arterienklemme193
Peck-Joseph, Face-lift Schere75
Pederson, Vaginalsekulum799
Peers-Bertram modif., Tuchklemme227
Peers-Bertram, Tuchklemme228
Peet, Splitterzange170
Penfield, Duradisektor689
Penisklemme795
Pennington, Arterienklemme184
Pennington, Septumlevatorium910
Percy, Amputationretraktor535
Periostelevatorium910
Peripheral-Gefäßklemme597, 600,
.....603, 616-617
Peritoneumklemme224-225
Pestalozza, Abortuskürette842
Petrischalengestell956
Phalangenzange526
Phaneuf, Hysterektomieklamme219
Phlebo dissektor349
Phleboextraktor349
Pierse, Mikro-Gewichts-Pinzette162
Pierse, Mikropinzette162
Piper, Geburtszange839
Pittsburgh, Leberklemme626
Plester, Lappenmesser859

Plester, Saugkanüle378
Plester, Wundspreizer309
Poltzer, Einsteckkonus881
Poltzer, Gummibirne881
Poltzer, Luftdusche881
Poltzer, Nasenolive881
Poltzer, Ohrolive881
Poltzer, Parazentesenadel878
Poltzer, Parazentesenadel878
Polloson, Wundhaken283
Polloson, Wundhaken284
Polypenschnürer870, 888
Poole, Saugrohr368
Poppen, Saugkanüle362
Potts, Anastomosenklemme615
Potts, Coarctationsklemme613-614
Potts, Mehrzweck-Gefäßklemme635
Potts, Mikroschere114
Potts-De Martell-Highmed, Präparierschere123
Potts-Smith, Anatomische Pinzette142, 145
Potts-Smith, Chirurgische Pinzette154
Potts-Smith, Gefäßschere83
Potts-Smith, Winkelschere83
Präparier- und Ligaturklemme615
Präparierklemme181, 185, 190, 192,
.....200-213, 217-218
Präparierschere34-39, 47-56, 58-74,
.....76-78, 82, 91, 101, 123-124,
.....126-128, 130, 135, 446-447
Pratt, Arterienklemme184
Pratt, Mastdarm-Rektum-Spekulum774
Price-Thomas, Bronchusklemme587
Probeexzisionszange826-830
Profundaklemme598
Prostatahaken785
Providence-Hospital, Arterienklemme188
Pudendusanästhesie-Kanüle376
Pulverbläser880
Putti, Knochenraspel482
Pylorusspreizer761

Q

Quattro, Gipsspreizer456
Querstab343
Quervain, Elevatorium513
Quire, Fremdkörperheber872

R

Ragnell, Präparierschere135
Ragnell-Davis, Wundhäkchen245
Rahmen327, 337-339, 565-568,
.....570, 572-574, 579-581
Rahmenhaken337-339
Ralk, Splitterzange170
Ramplay, Schwammzange237
Randall, Nierensteinzange780
Rändelschraube869
Raney, Anlege- und Abnehmzange685
Raney, Kopfhautklammer685
Rasierklängen4
Rasiermesser16
Raspatorium498-506, 508
Rasse, Knochenhäkchen240
Rasse, Mikrohäkchen240
Recamier, Uteruskürette832
Record-Arkansas, Abziehstein16
Redon, Führungsnadel374-375
Rees, Face-Lift Schere131
Reiner, Gipsmesser455
Reinigungsaufsatz972-973
Reinigungsbürste974-977
Rektum-Anastomosenklemme770-773
Rektumschere118
Repositionszange526, 528
Resano, Chirurgische Pinzette159
Resano, Rektum-Anastomosenklemme773
Resektionsmesser15
Reverdin, Nadel435
Reynolds, Chirurgische Schere78
Reynolds, Präparierschere77-78

Rhinoplastikmesser905
Ricard, Bauchdeckenhalter327
Ricard, Mittelvalve327
Ricard, Rahmen327
Richardson, Wundhaken268
Richardson-Eastman, Wundhaken267
Richter, Laminektomieezangen731
Richter, Wundklammerzange444
Ringmesser926
Ringstripper351
Rippenkontraktor584
Rippenkontraktor- u. Distraktor584
Rippenraspatorium507
Rippeneschere554-556
Rippensperrer558-568, 573-576
Ritter-Halle, Dilatationssonde926
Robb, Gefäßdissektor670
Roberts, Präparierklemme202
Rochester-Carmalt, Arterienklemme192
Roeder, Tuchklemme227
Roger, Septumlevatorium910
Rogers, Parametriumklemme221
Rollenklemme230
Rose, Trachealhaken741
Rosen, Mikro-Ohrnadel860
Rosen, Mikro-Ohrspatorium862
Rosen, Rundschnittmesser859
Rosenberg, Zangenaufsatz939
Ross, Aortahaken281-282
Roux, Wundhaken294
Roux-Baby, Wundhaken295
Roux-Mini, Wundhaken295
Rubin, Osteotom913
Rubin, Schutzkappe900
Rubin, Septumquetschzange900
Rückhaltefeder882
Rudd, Haemorrhoidal-Ligator776
Rudd, Ladekonus776
Rumel, Präparierklemme208
Rumel-Belmont, Tourniquet671
Rundschnittmesser859
Ruskin, HohlmeiBelzange540
Ruskin-Liston, Knochensplitterzange547
Russ, Modell, Chirurgische Pinzette157
Rydel-Seiffert, Stimmgabel869
Ryder (Martin), Nadelhalter427
Ryder-Vascular, Nadelhalter428

S

Saalfeld, Komedonenquetscher746
Sachs, Durahaken696-697
Sachs, Nervseparator687
Sachse, Meatotom794
Sachse, Messlehre794
Sägeblatt10, 458
Salenius, Meniskotom520
Salpingograph835
Salyer, Gaumenspaltendissektor932
Salyer, Gaumenspaltenelevatorium932
Salyer, Gaumenspaltenhaken932
Salyer, Gaumenspaltenschere72, 119
Samii, Fasspinzette702
Samii, Mikro-Gefäßmesser705
Samii, Tumormesser704
Sänger, Abortuszange840
Santullii, Bulldogklemme592
Sanvenero, Präparierschere72
Sarot, Nadelhalter425
Sarot, Präparierklemme202
Satinsky, Gefäßklemme627
Satinsky, Gefäßschere80
Satinsky, Tangentialklemme628
Sattelhäkchen243, 246-247, 923
Sauerbruch, Abfallzange974
Sauerbruch, HohlmeiBelzange544
Sauerbruch, Nadeletui957
Sauerbruch, Rippenschere555
Sauerbruch, Wundhaken277, 280
Saugansatz882

Sauger359, 363, 366-368, 370-371
Saugeraufsatz362, 373
Saugerhandgriff373
Saugkanüle348, 360-363, 377-378
Saugkürette825
Saugraspatorium926
Saugrohr359, 361, 364-365,
.....367-369, 372-373
Saugspitze367
Scalp-Contour, Wundspreizer301
Scapulahaken276
Schädel, Tuchklemme226
Schädelhalter683
Schädelspalter464
Schädelstanze684
Schädelzange684
Schale962
Schamberg, Komedonenquetscher746
Scharfe Kürette497
Scharfe Nasenzange893-894, 896, 898
Scharfer Doppellöffel496-497
Scharfer Löffel490-496
Schede, Scharfer Löffel491
Scheibe, Organfasszange765
Scheidenhalter801-805, 810
Scheinmann, Zangenaufsatz938
Scherbak, Gewicht zum Vaginalspekulum808
Scherbak, Griff zum Vaginalspekulum ...807, 808
Scherbak, Spekulum-Blatt807
Scherbak, Vaginalspekulum808
Schiebekloben343
Schink, Dermatome17
Schink, Ersatzklinge17
Schink, Spannplatte17
Schlauchklemme228-229
Schlaucholive367
Schlauchverbinder380
Schleimhautmesser859
Schlinge936
Schlingendreher443
Schlingenhalter870
Schlüssel f. Approximatoren174
Schmeden, Scharfe Nasenzange898
Schmid, Gefäßkanüle379
Schmieden, Führungshohlsonde442
Schmieden, Unterbindungsnadel436
Schmieden-Dick, Unterbindungsnadel436
Schmieden-Payr, Führungshohlsonde442
Schmieden-Taylor, Duraschere90
Schneider, Raspatorium501
Schnidt, Präparierklemme192
Schnidt, Tonsillenklemme935
Schnürdraht870, 888, 936
Schraubenaufsatz für Venen668
Schraube521
Schraubolive668
Schröder, Hakenzange817-818
Schubert, Probeexzisionszange826-827
Schuhmacher, Nabelschnurschere98
Schuknecht, Sichelmesser859
Schultze, Manometer zum Salpingograph835
Schultze, Salpingograph835
Schumacher, Aufsatz830
Schumacher, Probeexzisionszange829-830
Schumacher, Zangenaufsatz939
Schutzkappe900
Schutzschild952
Schutzteller882
Schwammzange235-237
Schwenkkopf-Klingenhalter6
Schwesterngarnitur950
Schwingmesser906
Scoville, Blattvalve341
Scoville, Hakenvalve341
Scoville, Laminektomiesperrer340
Scoville, Scharfer Löffel493
Scoville-Haverfield, Laminektomiesperrer340
Scudder, Darmklemme770
Sebileau, Elevatorium513
Sedillot, Raspatorium501, 504

Segond, Myommesser822
Sehndurchzuginstrument521
Sehndurchzugssonde522
Sehndurchzugzange523
Sehneneinflechtklemme524
Sehnenschnur524
Sehnenschnur524
Sehnenschnur523, 524
Sehnenschere108-109
Sehnenstripper521-522
Seiffert, Zangenaufsatz938
Seitenvalve324-329, 558, 565-571,
.....573-574, 577-582
Sellheim, Geburtslöffel840
Sellors, Rippenkontraktor- u. Distraktor584
Semb, Bronchusklemme588
Semb, Hohlmeißelzange540
Semb, Knochenhaltezeange529
Semb, Knochensplitterzange549
Semb, Raspatorium508
Semken, Anatomische Pinzette141
Semken, Chirurgische Pinzette143, 152
Semm, Vaginalsepekulum799
Senn-Green, Wundhäkchen245
Senn-Miller, Wundhäkchen245
Septumlevatorium907-910
Septum-Hohlmeißel911
Septummeißel911
Septummesser906
Septumquetschzange899-900
Septumrichtzange924
Septumschere899
Septumzange891, 899, 924
Set "Kleine Wundversorgung"446
Sewall, Raspatorium501
Shaaf, Fremdkörperpinzette168
Shambaugh, Mikro-Ohrhäkchen862
Shapleigh, Ohrkürette876
Shea Vein Graff, Venenschere75
Shea, Sondierhaken862
Sichelmesser859
Siebbeinzange892-895
Silikonereinlage959
Silver, Handdermatom17
Silver, Nasenmeißel914
Simon, Fistelhaken824
Simon, Scharfer Löffel493
Simon, Uteruslöffel831
Simon, Wundhaken274
Simpson, Geburtszange838
Sims, Mastdarm-Rektum-Spekulum774
Sims, Uteruskürette832
Sims, Uterusschere40-41
Sims, Uterussonde816
Sims, Vaginalsepekulum800
Sims-Aquila, Uterusschere41
Sims-Siebold, Uterusschere45
Sims-TCC-BlackLine, Uterusschere41
Singley-Tuttle, Fasspinzette158
Sinusklemme233
Skalpelloff5-9, 12, 446-447
Skalpelloffklinge10-11
Skalpelloffklingenentferner10
Skene, Hakenzange818
Smillie, Meniskotom520
Smith-Petersen, Hohlmeißel478
Smith-Petersen, Osteotom477
Smithwick, Nervhaken695
Snyder-O.S.U, Hohlmeißel464
Somer, Uterusfasszange823
Sonde845
Sondierhaken862
Spannarm690, 691, 692
Spannhalter691-692
Spannplatte17
Spannschlüssel470
Spatel694
Spatelhalter690-692
Spekulum-Blatt807
Spencer, Ligaturschere119-120
Spencer-Wells, Arterienklemme182

Sphinkteroskop776
Spinalhaken519
Splitterpinzette166-168
Splitterzange170
Spongiosameißel471
Spratt, Scharfer Löffel492
Spritze381, 882
Spülansatz883
Spülkanüle926
St. Barts, Siebbeinzange895
St. Marks, Beckenhaken292-293
Stacke, Ohrsonde346
Standgefäß964
Stella-S, Face-Lift-Schere747
Stellbrink, Hohlmeißelzange536
Sterilisierklammer960
Sterilisierzange956
Sternummeißel556
Sternumsperrer558
Sternumspreizer563
Stevens, Chirurgische Schere108-109
Stevens, Sehnenschere108-109
Stieglitz, Splitterzange170
Stille, Anatomische Pinzette139
Stille, Chirurgische Pinzette151
Stille, Flachmeißel468
Stille, Hohlmeißel469
Stille, Hohlmeißelzange540
Stille, Osteotom468-469
Stille-Barraya, Chirurgische Pinzette157
Stille-Liston, Knochensplitterzange547-548
Stille-Luer, Hohlmeißelzange543
Stille-Martin, Gippschere453
Stille-Ruskin, Hohlmeißelzange541
Stimmgabel866-869
Stirnreif952
Stockmann, Penisklemme795
Stone-Watt, Darm-Anastomosenklemme762
Stone-Watt, Klemmschloß762
Strabimusschere110
Strandell-Stille, Wundhäkchen248
Stratte, Nadelhalter416, 429-430
Strauss, Penisklemme795
Strully, Neurochirurgische Schere90
Strümpel, Ohrpolypenzange873
Struycken, Scharfe Nasenzange896
Subramanian, Klemme672
Subramanian-Miniature, Klemme672

T

Tabb, Schleimhautmesser859
Takahashi, Siebbeinzange892
Tamponstopfer934
Tangentialklemme628
Taylor, Anatomische Pinzette141
Taylor, Chirurgische Pinzette153
Taylor, Hakenvalve341
Taylor, Spinalhaken519
TCC-BlackLine, Hysterektomieschere132-133
Teale, Hakenzange818
T-Griff350
Thoms-Allis, Darm- und Gewebefasszange751
Thoms-Gaylor, Probeexzisionszange827
Thoraxsperrer570, 572, 579-580, 583
Thorek, Präparierschere63
Thymushaken741
Thyreoid- und Vulva-Spreizer323
Tieck-Halle, Nasenspekulum885
Toennis, Dura-Doppeldissektor686
Toennis, Nadelhalter418, 433
Toennis, Präparierschere91
Toennis-Adson, Präparierschere91, 129
Tohoku, Tuchklemme227, 446-447
Tönnis-Adson TCC-BlackLine,
Präparierschere129
Tönnis-Adson-Aquila, Präparierschere129
Tonsillenelevatorium933-934
Tonsillenfasszange935
Tonsillenanüle364, 377

Tonsillenklemme935
Tonsillennesser933
Tonsillennesser-/Eukleator933
Tonsillenschere93-94
Tonsillenschnürer936
Tonsillenzange935, 937
Tourniquet671
Toynbee, Ohrspekula, Satz864
Toynbee, Ohrspekulum864
Trachealdilatator740
Trachealhaken741
Trelat, Raspatorium500
Trelat, Vaginalsepekulum799
Trigeminusschere92
Trokar358
Trötsch (Wilde), Ohrpinzette871
Trötsch, Nasentamponpinzette890
Trousseau, Trachealdilatator740
Troutman-Chris, Klingenthaler4
Tubbs, Aorta-Dilatator665
Tubenfasspinzette159
Tuberkulinspritze383
Tuchklemme226-228, 446-447
Tuffier, Arterienklemme183
Tuffier, Rippensperrer563
Tumorfasszange184, 732
Tumorgabel704
Tumormesser704
Tumorphinzette702
Tunnelier-Griff668
Tunnelier-Korzange234
Tunnelierschaft668
Tunnelier-Set668
Tuohy, Lumbalpunktkanüle377
Tupferzange235
Turnbull, Nagelzange950
Tyding, Tonsillenschnürer936

U

Überwurfmutter532, 969
Uhrmacher-Pinzette156
Ulrich, Knochenhaltezeange531
Ulrich, Korn- u. Tupferzange232
Universal, Drahtschere121
Universal, Pulverbläser880
Universal, Trokar358
Universal, Verbandschere452
Universal-Befestigungskloben342, 343
Universalgriff830
Unna, Komedonenquetscher746
Unna-Vidal, Komedonenquetscher746
Unterbindungsnadel436-440
Urethrographieinstrument793
Urethrotom792
Uro-Tangentialklemme214
Uterusdepressor816
Uterusdilatator811-815
Uterusdilatatore, Satz812
Uterusfasszange823
Uteruskürette831-832, 834
Uteruslöffel831
Uteruspolypenzange821
Uterusschere40-41, 44-46
Uterussonde816

V

Vaginalsepekulum798-810
Valleix, Uterussonde816
Valve315-316
Van Buren, Harnröhrenbougie790
Van Doren, Probeexzisionszange828
Vannas, Mikroschere698
Varady, Mikrodissektor349
Varady, Mikro-Phlebextraktor349
Varady, Mini-Phlebextraktor349
Varady, Olive348
Varady, Phlebextraktor349
Varady, Phlebodissektor349
Varady, Varizenbesteck348

Varizenbesteck348, 350
Veidenheimer, Rektum-
 Anastomosenklemme772
Vena Cava-Klemme.....625
Venenhäkchen.....248
Venenkanüle376
Venenschere75
Ventilaufsatz882
Ventilball.....880
Verbandschere450, 452, 454
Verbindungsschlauch.....795, 882
Verbrugge, Knochenhaltezange534, 535
Verhoeven, Saugkanüle377
Verlängerungsrohr.....830
Verres, Insufflationskanüle378
Verschlussklemme762
Vickers Low-Profile, Mittelvalve322
Vickers Low-Profile, Wundspreizer.....322
Vickers, Wundspreizer322
Vidal, Lupusschaber744
Virchow, Hirnmesser3
Virchow, Schädelspalter464
Volkmann, Scharfer Doppellöffel496
Volkmann, Scharfer Löffel490, 491
Volkmann, Wundhaken250-252
Vollmar, Gefäß-Spülkanüle378
Vollmar, Ringstripper351
Vorböhrer.....683

W
Wachenfeldt, Wundklammerpinzette444
Wagener, Ohrhäkchen878
Wagner, Chirurgische Schere100
Wagner, Laminektomiezangen730
Walldmann, Episiotomieschere97
Walter, Hohlmeißel913
Walter, Osteotom913
Wangenstein, Anatomische Pinzette146
Wangenstein, Nadelhalter416, 428
Waschschüssel.....962
Wasserstrahl-Reinigungspistole.....968
Wassmund, Wundhaken256
Watson-Cheyne, Doppeldissektor.....513
Watson-Williams, Siebbeinzange.....893
Watteträger352
Waugh, Anatomische Pinzette.....140
Waugh, Chirurgische Pinzette152
Weber, Aortaklemme624
Weber-Loch, Ohrschlinge.....877
Webster, Nadelhalter412, 419, 423-424
Weil, Scharfe Nasenzange893
Weil-Blakesley, Scharfe Nasenzange.....894
Weil-Blakesley, Siebbeinzange894-895
Weissbarth, Auffangsieb.....810
Weissbarth, Vaginalsekulum810
Weitlaner, Wundspreizer.....30, 303,
 306-307, 446-447
Weitlaner-Baby, Wundspreizer311
Weitlaner-Wullstein, Wundspreizer308
Wertheim, Hysterektomieklemme223
Wertheim, Uterusschere46
Wertheim-Cullen, Hysterektomieklemme.....220
Westcott, Strabismusschere.....110
Westmacott, Nasentamponzange.....890
White, Tonsillenfasszange935
Wikstroem, Präparierklemme211
Williams, Darm- und Gewebefasszange.....752
Williams, Wundspreizer310
Williger, Elevatorium513
Williger, Hammer484, 486
Williger, Raspatorium.....505
Williger, Scharfer Doppellöffel497
Winkelschere83, 107, 134
Winter, Abortuszange840
Wirbelkörperspreizer710-711
Wolff, Gipsabreisszange457
Wolff, Lupuslöffel744
Wrigley, Geburtszange838
Wullstein, Mikro-Ohrscherchen855
Wullstein, Sauger363

Wullstein, Saugkanüle363
Wullstein, Sichelmesser859
Wund- u. Blasenpistole384
Wundhäkchen.....241-245,
 248-249, 446-447
Wundhaken249-275, 277-280,
 283-291, 294-297, 343
Wundklammern445
Wundklammerpinzette444
Wundklammerzange444
Wundrandpinzette444
Wundspreizer.....30, 298-323, 446-447
Wylie, Aortaklemme.....601, 625

X

Xenonlampe.....398

Y

Yankauer, Handgriff367
Yankauer, Sauger.....366, 367
Yankauer, Saugrohr.....367
Yankauer, Saugspitze367
Yankauer, Schlaucholive.....367
Yasargil, Fadenführer706
Yasargil, Fasspinzette702
Yasargil, Galeahaken686
Yasargil, Hypophysenzange731, 732
Yasargil, Mikro-Dissektor707
Yasargil, Mikro-Gefäßmesser.....705
Yasargil, Mikro-Kürette.....708
Yasargil, Mikro-Nadelhalter.....701
Yasargil, Mikropinzette702
Yasargil, Mikro-Präparierschere699
Yasargil, Mikro-Raspatorium706
Yasargil, Mikroschere699
Yasargil, Saugrohr365
Yasargil, Tumorgabel704
Yasargil, Tumorpinzette702
Yasargil-Samii, Fasspinzette702
Young, Nadelauufsatz436
Young, Nadelhalter436
Young, Prostatahaken785

Z

Zahnfleischschere99, 101-102
Zangenaufsatz938-939
Zanger, Aortaklemme606
Zaufal, Fremdkörperheber877
Zaufal-Jansen, Hohlmeißelzange.....539
Zeller, Infektionsschutzbrille.....952
Zenker, Präparierklemme209
Zenker, Wundhaken265
Zielke, Hohlmeißel467
Zöllner, Ohrspekula, Satz865
Zöllner, Ohrspekulum.....865
Zöllner, Saugaufsatz362
Zöllner, Saugkanüle362
Zugseil350
Zweifel, Nadelhalter434
Zwischenstück380

Index, alphabetical
English

i

- A**
- Abdominal Retractor.....324-338
- Abdominal Spatula.....293, 344
- Adenoid Curette.....926
- Adlerkreutz, Dissecting Forceps.....151
- Adson, Dissecting and Ligature Forceps.....192
- Adson, Dissecting Forceps.....144, 152
- Adson, Dressing Forceps.....140, 144
- Adson, Dura Hook.....696
- Adson, Elevator.....510
- Adson, Needle Holder.....413
- Adson, Suction Cannula.....360
- Adson, Wound Spreaders,
self-retaining.....304-306, 313-314, 318
- Adson-Baby, Dissecting and
Ligature Forceps.....201
- Adson-Brown, Dissecting Forceps.....144, 155
- Air Bag.....881
- Alan-Parks, Rectal Spreader.....775
- Alar Hooklet.....921-923
- Alderdyce, Dissector, double-ended.....513
- Alexander, Chisel.....467
- Alexander, Gouge.....467
- Alexander, Periosteal Elevator.....508
- Alexander, Uterine Biopsy Forceps.....829
- Allen, Intestinal Clamp.....758
- Allenberg-Cobra, Multi purpose
Vascular Clamp.....664
- Allis, Intestinal and Tissue Grasping
Forceps.....750-751
- Allis-Adair, Intestinal and
Tissue Grasping Forceps.....751
- Allis-Baby, Intestinal and
Tissue Grasping Forceps.....750
- Allison, Lung Spatula.....586
- Alm, Wound Spreaders, self-retaining.....300
- Amniotome.....817
- Amputation Knife.....15
- Amputation Retractor.....535
- Anastomosis Clamp.....615, 631-632, 642,
657-658, 660, 662, 664
- Anderson-Adson, Wound Spreaders,
self-retaining.....301
- Aneurysm Clamp.....634
- Antrum Curette.....925
- Antrum Irrigation Cannula.....926
- Antrum Punch.....897, 904
- Antrum Rasp.....917
- Anuscope.....774
- Aorta Punch.....557
- Aorta Retractor.....281-282
- Aortic Aneurysm Clamp.....619-620
- Aortic Clamp.....595, 601-602, 606-609,
621, 624-625, 633, 655
- Aortic Dilator.....665
- Applying Forceps.....612
- Applying/Removal Forceps.....685
- Approximation Forceps.....444
- Approximator.....172-174
- Aquila, Hysterectomy Scissors.....132-133
- Arruga, Micro Needle Holder.....408
- Arruga, Needle Holder.....411, 422
- Asch, Septum Straightening Forceps.....924
- Aston, Face-lift Scissors.....57
- Atomizer.....880
- Atraumatic Dressing Forceps.....142, 147-148
- Atraumatic Micro Forceps.....165
- Atrium Retractor.....289
- Attic Dissector.....862
- Aufricht, Glabella Rasp.....918
- Aufricht, Nasal Retractor.....921, 923
- Auricle Clamp.....629
- Austin, Attic Dissector.....862
- Austin, Micro Tying Forceps.....167
- Auvard, Vaginal Speculum.....809
- Ayre, Conization Knife.....824
- B**
- Babcock, Intestinal and Tissue
Grasping Forceps.....752-753
- Baby-Adson, Haemostatic Forceps.....185
- Baby-Poole, Suction Tube.....368
- Backhaus, Towel Clamp.....226
- Bailey, Rib Contractor.....584
- Bailey-Baby, Rib Contractor.....584
- Bailey-Gibbon, Rib Contractor.....584
- Bainbridge, Multi purpose Vascular Clamp.....618
- Bakelit base.....869
- Bakes, Gall Duct Dilator.....781
- Balfour, Abdominal Retractor.....332-333
- Balfour, Central Blade.....332, 334-335
- Balfour, Mod. USA, Abdominal Retractor.....335
- Balfour, Mod. USA, Fenestrated Blade.....335
- Balfour-Baby, Abdominal Retractor.....331
- Balfour-Standard, Abdominal Retractor.....334
- Ball Socket Joint.....692, 693
- Ballenger, Septum Gouge.....911
- Ballenger, Swivel Knife.....906
- Ballenger-Hajek, Septum Elevator.....909
- Bandage Scissors.....450, 452, 454
- Barbara, Micro Ear Hook.....860
- Barbara, Micro Ear Needle.....860-861
- Baron-Schuknecht, Suction Tube.....363
- Barraquer, Cilia Forceps.....169
- Barraquer, Micro Needle Holder.....409, 423
- Barraquer-Troutman, Micro Needle Holder.....408
- Battery Container.....398
- Battery Handle.....391, 392, 394, 396, 398
- Beacham, Amniotome.....817
- Beck, Multi purpose Vascular Clamp.....642, 651
- Beckman-Adson, Wound Spreaders,
self-retaining.....319
- Beckman-Eaton, Wound Spreaders,
self-retaining.....320
- Beckmann, Adenoid Curette.....926
- Beckmann, Wound Spreaders, self-retaining.....317
- Beebe, Wire Cutting Scissors.....122
- Beer, Cilia Forceps.....169
- Bellucci, Micro Ear Scissors.....854
- Bengolea, Haemostatic Forceps.....195
- Bennett, Bone Lever.....518
- Benson, Pylorus Spreader.....761
- Bergmann, Plaster Shears.....451
- Bergmann, Sponge Forceps.....236
- Bernhard, Towel Clamp.....227
- Bethune, Rib Shear.....555
- Beyer, Bone Rongeur.....539
- Beyer, Mastoid Rongeur.....875
- Biemer, Micro scissors for veins.....116
- Biemer, Vessel Clip.....172
- Biemer-Müller, Approximator.....173
- Bile Duct Clamp.....213, 216
- Billeau, Ear Loop.....877
- Bircher-Ganske, Cartilage Seizing Forceps.....525
- Bladder Neck Spreader.....788
- Bladder Retractor.....788-789
- Blade.....341
- Blade.....337-339
- Blade Holder / Blade Breaker.....4
- Blades, (pair).....315-316
- Blake, Gall Stone Forceps.....782
- Blake, Uterine Scoop.....831
- Blohmke, Tonsil Grasping Forceps.....935
- Blount, Knee Retractor.....519
- Blumenthal, Bone Rongeur.....538
- Böhler, Bone Cutting Forceps.....546
- Böhler, Bone Rongeur.....539
- Bone Chisel.....464-467, 469, 472-473,
478-479, 481, 913
- Bone Chisel.....464, 913
- Bone Curette.....490-497
- Bone Curette, double-ended.....496-497, 925
- Bone Cutting Forceps.....545-549
- Bone File.....509-511, 917
- Bone Holding Forceps.....525-528, 529-535
- Bone Hooklet.....240
- Bone Lever.....514-519
- Bone Rasp.....482
- Bone Rongeur.....536-544
- Bone Separator.....710
- Bone Shear.....554
- Bonney, Dissecting Forceps.....143, 158
- Borowski, Aorta Retractor.....282
- Bowman, Probe.....845
- Boys-Allis, Intestinal and Tissue
Grasping Forceps.....751
- Bozemann, Knot Tier.....443
- Bozemann, Needle Holder.....429
- Bozemann, Sponge Forceps.....235
- Brain Knife.....3
- Brain Spatula.....690
- Braun, Uterine Depressor.....816
- Braun, Uterine Tenaculum Forceps.....817, 820
- Braun-Stadler, Episiotomy Scissors.....97
- Breisky, Vaginal Speculum.....810
- Brom, Vein Hook.....248
- Brompton, Tube milking roller.....230
- Bronchus Clamp.....587-588, 630
- Brophy, Dissecting Forceps.....153
- Brown, Needle Holder.....413
- Brünings, Exchangeable Tip.....938
- Brünings, Interchangeable Tube.....830
- Brünings, Laryngeal Tube.....937, 938, 939
- Brünings, Septum Forceps.....891
- Brünings, Tonsil Knife.....933
- Brünings, Tonsil Snare.....936
- Brunner, Ligature Conductor.....440, 442
- Brunner, Ligature Needle.....440
- Brunner, Retractor.....278-279
- Brunner, Rib Shear.....556
- Brunner, Sigmoid Anastomosis Forceps.....770
- Bruns, Bone Curette.....492-493
- Bruns, Plaster Scissors.....452, 454
- Brush Collecting Box.....949
- Brush Dispenser.....948
- Buck, Ear Curette.....876
- Buck, Foreign Body Lever.....872
- Buck, Stitch Scissors.....120
- Buckley, Wound Spreaders, self-retaining.....299
- Bulldog Clamp.....176-181, 589,
590-592, 611-612
- Bulldog Clamp.....593
- Burford, Rib Retractor.....560
- Busch, Umbilical Scissors.....98
- Bushe, Bone Curette.....495
- Button ended Tip.....882
- Byrd, Suction Tube.....373
- C**
- Caliper.....844
- Calne, Forceps for Vena Cava.....625
- Cannula.....376
- Caplan, Septum Forceps.....899
- Capsule Forceps.....786-787
- Carotid Clamp.....659
- Carotid Shunt Clamp.....599
- Carpenter, Tonsil Knife / Enuclator.....933
- Cartilage Crusher.....916
- Cartilage Seizing Forceps.....525-526
- Case for Laryngoscopes.....391
- Caspar, Laminectomy Rongeurs.....724-729
- Caspar, Micro Dissector.....705
- Caspar, Micro Scissors.....700
- Caspar, Nerve and Vessel Hooklet.....709
- Caspar, Suture fork.....705
- Caspar, Tamper.....483
- Castañeda, Neonatal Vascular Clamp.....677
- Castañeda, Rib Retractor.....561
- Castroviejo, Blade Holder / Blade Breaker.....4
- Castroviejo, Caliper.....844
- Castroviejo, Micro Needle Holder.....404-405,
410-411, 422-423
- Castroviejo, Micro Scissors.....111
- Castroviejo-Epker, Caliper.....844
- Castroviejo-Fino, Micro Needle Holder.....409
- Catheter Clamp.....604-605
- Catheter Fitting.....380
- Catheter Introducing Forceps.....386
- Central Blade.....312, 322, 325-327,
330-336, 775, 789

Cerullo, Suction Tube365
 Chaput, Haemostatic Forceps183
 Cheattle, Sterilizing Forceps956
 Cheron, Dressing Forceps235
 Childe, Approximation Forceps444
 Chisel465-468, 480
 Chisel Blade470
 Cilia Forceps169
 Cinelli, Nasal Scissors63
 Cinelli, Osteotome914
 Circular Cut Knife859
 Circumcision Instrument793
 Citelli, Mastoid Rongeur874
 Clamp Holder761
 Cleaning Brush974-977
 Cleansing Tip972-973
 Cleft Palate Dissector932
 Cleft Palate Elevator932
 Cleft Palate Hooklet932
 Cleft Palate Periosteal Rasapatory907, 932
 Cleveland, Bone Cutting Forceps546
 Cleveland, Bone Rongeur536
 Clip Applying Forceps172, 175, 444, 685
 Closing Forceps760, 762
 Cloward, Blades, (pair)315-316
 Cloward, Lamina Spreader710
 Cloward, Wound Spreaders,
 self-retaining315-316
 Coakley, Antrum Curette925
 Coarctation Clamp613-614
 Cobb, Gouge479
 Cobbs, Periosteal Elevator503
 Cogswell, Suction Tube373
 Collier, Needle Holder412
 Collin, Abdominal Retractor324-326,
 328-329
 Collin, Dressing Forceps235
 Collin, Mallet485
 Collin, Organ Grasping Forceps184
 Collin, Scalpel Handle6
 Collin, Tumor Grasping Forceps184
 Collin, Umbilical Cord Clamp842
 Collin, Uterine Seizing Forceps823
 Collin, Vaginal Speculum798
 Collin-Baby, Abdominal Retractor324, 327,
 328, 329
 Collin-Hartmann, Retractor294
 Columella Forceps925
 Comedone Extractor746
 Cone793
 Cone, Cranial Punch684
 Conical Tip882
 Conization Knife824
 Connecting Nozzle881
 Connector380
 Converse, Alar Hooklet922
 Converse, Nasal Retractor922
 Converse, Nasal Scissors96
 Converse, Rhinoplastic Knife905
 Cooley, Anastomosis Clamp657-658, 660
 Cooley, Aortic Clamp608-609, 621
 Cooley, Aortic Dilator665
 Cooley, Atrial retractor582
 Cooley, Atrium Retractor289
 Cooley, Carotid Clamp659
 Cooley, Catheter Clamp605
 Cooley, Iliac Clamp658
 Cooley, Lateral Blade573, 578
 Cooley, Multi purpose
 Vascular Clamp647-648, 659-663
 Cooley, Pediatric Vascular Clamp657
 Cooley, Rib Retractor558-559
 Cooley, Suction Tube370-371
 Cooley, Vascular Dilator666
 Cooley, Vascular Forceps656
 Cooley-Beck, Anastomosis Clamp664
 Cooley-Derra, Anastomosis Clamp662, 664
 Cooper, Ligature Needle437
 Cordes, Exchangeable Tip939
 Coronary Scissors82, 85-87, 89

Coronary spreader585
 Coryllos, Retractor275
 Cottle, Alar Hooklet923
 Cottle, Cartilage Crusher916
 Cottle, Columella Forceps925
 Cottle, Guide Support916
 Cottle, Mallet485
 Cottle, Nasal Hook921
 Cottle, Nasal Rasp917
 Cottle, Nasal Retractor923
 Cottle, Nasal Scissors95-96
 Cottle, Nasal Speculum886-887
 Cottle, Osteotome912
 Cottle, Periosteal Elevator910
 Cottle, Periosteal Elevator501
 Cottle, Rhinoplastic Knife905
 Cottle, Saddle Hook923
 Cottle, Septum Elevator909-910
 Cottle, Skin Grasping Forceps925
 Cottle, T-Handle916
 Cottle-Kazanjian, Bone Cutting Forceps545
 Cottle-Neivert, Alar Hooklet923
 Cottle-Walsham,
 Septum Straightening Forceps924
 Cotton Applicator352
 Coupland, Suction Handle373
 Coupland, Suction Tip373
 Coupling532, 969
 Coupling head691-693
 Coupling Piece834
 Craford, Dissecting and Ligature Forceps203
 Craford, Vascular Clamp203
 Craford-Sellors, Vascular Clamp203
 Cranial Punch684
 Cranial Rongeur684
 Crile, Haemostatic Forceps190
 Crile, Needle Holder417
 Crile, Nerve Hooklet671
 Crile-Murray, Needle Holder413
 Crile-Rankin, Haemostatic Forceps191
 Crile-Wood, Needle Holder413, 419,
 424, 446-447
 Cross Bar343
 Crutchfield, Skull Traction Tong683
 Cusco, Vaginal Speculum798
 Cushing, Dissecting Forceps154
 Cushing, Dressing Forceps142, 145
 Cushing, Nerve Hook695
 Cushing, Retractor245
 Cushing, Saddle Hook246
 Cushing-Landolt, Pituitary specula733
 Cushing-Taylor, Dressing Forceps145
 Cuticle Nipper951
 Cuticle Scissors951
 Cuzzi, Placenta Scoop841
 Czerny, Rectal Speculum774
 Czerny, Uterine Tenaculum Forceps820

D

Dahlgren, Cranial Rongeur684
 Dale, Peripheral Vascular Clamp597
 Damper869
 Dandy, Haemostatic Forceps191
 Dandy-Mosquito, Haemostatic Forceps191
 Dardik, Multi purpose Vascular Clamp596
 Dartigues, Uterine Seizing Forceps823
 d'Assumpção, Face-lift Forceps747
 Daubenspeck, Bone Curette491
 Davidson, Scapula Retractor276
 Davis, Dura Dissector688
 Day, Ear Hooklet878
 De Bakey, Anastomosis Clamp632
 De Bakey, Angled Scissors134
 De Bakey, Aortic Aneurysm Clamp619-620
 De Bakey, Aortic Clamp621, 655
 De Bakey, Applying Forceps612
 De Bakey, Atraumatic
 Dressing Forceps147-148
 De Bakey, Bulldog Clamp591

De Bakey, Dissecting Scissors62
 De Bakey, Lateral Blade565-569
 De Bakey, Ligature Forceps622-623
 De Bakey, Ligature Forceps615
 De Bakey, Multi purpose
 Vascular Clamp618, 636-637,
 639-641, 650
 De Bakey, Needle Holder426
 De Bakey, Pediatric Vascular Clamp643
 De Bakey, Peripheral Vascular Clamp616
 De Bakey, Retractor, only565-568
 De Bakey, Rib Retractor565-568
 De Bakey, Suction Tube366
 De Bakey, Vascular Dilator667
 De Bakey, Vascular Forceps610-611
 De Bakey, Vascular Scissors82
 De Bakey-Adson, Suction Tube366
 De Bakey-Bahnsen, Aneurysm Clamp634
 De Bakey-Beck, Anastomosis Clamp642
 De Bakey-Derra, Multi purpose
 Vascular Clamp652
 De Bakey-Diethrich, Bulldog Clamp178
 De Bakey-Mosquito, Haemostatic
 Forceps594, 638
 De Bakey-Pean, Haemostatic Forceps638
 De Bakey-Rankin, Haemostatic Forceps594
 De Bakey-Reynolds, Multi purpose
 Vascular Clamp641
 De Bakey-Satinsky, Bulldog Clamp592
 De Bakey-Satinsky, Multi purpose
 Vascular Clamp653
 De Martel, Wire Saw Guide682
 De Martel-Wolfson, Clamp Holder761
 De Martel-Wolfson, Closing Forceps760
 De Martel-Wolfson,
 Intestinal Anastomosis Clamp760
 De Vilbiss, Cranial Rongeur684
 Dean, Tonsil Scissors93-94
 Deaver, Operating Scissors33
 Deaver, Retractor286-288
 DeBakey, Aortic Clamp602
 Derf, Needle Holder412, 423
 Dermal Punch745
 Dermatome17
 Derra, Anastomosis Clamp642
 Deschamps, Ligature Needle438-439
 Desjardins, Bile Duct Clamp216
 Desjardins, Gall Stone Forceps783
 Desmarres, Saddle Hook243
 Dieffenbach, Bulldog Clamp176
 Diethrich, Aortic Clamp595
 Diethrich, Bulldog Clamp178
 Diethrich, Vascular Scissors81, 84, 89
 Diethrich-Salyer, Dissecting Scissors82
 Dingmann, Cartilage Seizing Forceps525
 Disposable Scalpel13-14
 Dissecting and Ligature Forceps181, 185,
 190, 192, 200-213, 217-218
 Dissecting Forceps143-144, 146-147,
 149-155, 157-160, 446-447
 Dissecting Forceps158, 702-703
 Dissecting Knife2
 Dissecting Needle402-403
 Dissecting Scissors34-39, 47-56, 58-74,
 76-78, 82, 91, 101, 119
 123-124, 126-128,
 130, 135, 446-447
 Dissector, double-ended513
 Douglas, Cilia Forceps169
 Doyen, Grooved Director347
 Doyen, Gynecological Scissors44
 Doyen, Intestinal Clamp754, 766
 Doyen, Mallet484
 Doyen, Myoma Screw822
 Doyen, Retractor273
 Doyen, Rib Raspatory507
 Doyen, Vaginal Retractor810
 Doyen, Vaginal Speculum806
 Doyen-Baby, Intestinal Clamp755, 766
 Doyen-Stille, Retractor269
 Drainage forceps557

Dressing Forceps.....138-147, 154-155,
.....160, 232-235, 446-447
Dressing Forceps in jar, with cap.....960
Drill Point.....683
Dubost, Lateral Blade.....570, 571
Dubost, Retractor, only.....570
Dubost, Thoracic Retractor.....570
Dunhill, Haemostatic Forceps.....189
Duplay, Uterine Tenaculum Forceps.....817
Dura Dissector.....686-689
Dura Hook.....696-697
Dura Scissors.....90
Durante, Dissecting Forceps.....157
Duval, Intestinal and Tissue Grasping
Forceps.....753-754

E

Ear Cannula.....880
Ear Catheter.....870
Ear Curette.....876
Ear Forceps.....871
Ear Hooklet.....877-878
Ear Olive.....881
Ear Polypus Forceps.....872-873
Ear Probe.....346
Ear Scoop.....877, 879
Ear Scoop/Hook.....877
Ear Specula Storage Rack.....865
Ear Specula, Set.....864-865
Ear Speculum.....864-865
Ear Syringe.....882-883
Echlin, Bone Rongeur.....541
Eicken-Killian, Antrum Irrigation Cannula.....926
Eiselsberg, Stitch Scissors.....120
Elevator.....510, 512-513
Emmett, Fistula Hook.....824
Endocervical Speculum.....811
Endocervical Speculum.....811
Enterotomy Scissors.....118
Enucleation Scissors.....110
Episiotomy Scissors.....97
Episiotomy Scissors.....97
Esmarch, Plaster Knife.....455
Esmarch, Plaster Shears.....451
Ethmoid Bone Forceps.....892-895
Eves, Tonsil Snare.....936
Exchangeable Tip.....938-939
Exploring Hook.....862

F

Face Protection Mask.....952
Face-lift Forceps.....185, 747
Face-lift Hooklet.....745
Face-lift Scissors.....57, 75, 119, 131, 747-748
Fahlbusch, Micro Scissors.....700
Farabeuf, Bone Holding Forceps.....530
Farabeuf, Periosteal Elevator.....502
Farabeuf, Retractor.....295
Farabeuf-Collin, Periosteal Elevator.....502
Farell, Cotton Applicator.....352
Farrior, Ear Speculum.....865
Fasciotomy Spatula.....669
Faulkner, Curette double ended.....925
Faure, Peritoneum Forceps.....225
Faure, Uterine Biopsy Forceps.....826
Favaloro, Vascular Scissors.....88, 90
Fehland, Sigmoid Anastomosis Forceps.....772
Feilchenfeld, Splinter Forceps.....167
Fenestrated Blade.....335
Fergusson, Bone Holding Forceps.....527
Fergusson, Suction Tube.....361
Ferris-Smith-Kerrison,
Sphenoid Bone Punch.....902
Fiber Optic Light Carrier.....775
Filiform Bougie.....791
Filiform, Filiform Bougie.....791
Finocchio (modif.), Rib Retractor.....561
Finocchio, Baby, Rib Retractor.....564
Finocchio, Dissecting
and Ligature Forceps.....213

Finocchio, Infant, Rib Retractor.....559
Finocchio, Needle Holder.....415, 427
Finocchio, Rib Retractor.....560, 564
Finsen, Wound Spreaders, self-retaining.....298
Finsen-Martin, Wound Spreaders,
self-retaining.....298
Fisch, Micro Dissector.....862
Fisher, Tonsil Knife.....933
Fistula Hook.....824
Fistula Probe.....347
Fitting.....792
Fixation Arm.....343, 692-693
Fixation device.....690, 691
Fixing device for hooks.....343
Flap Knife.....859
Flexible arm.....690, 691, 692
Flexible Tube.....795, 882
Fomon, Alar Hooklet.....921-922
Fomon, Bone File.....918, 920
Fomon, Chisel.....913
Fomon, Nasal Scissors.....63, 95
Fomon, Rhinoplastic Knife.....905
Foot support.....868
Forceps for kidney and pancreas.....627
Forceps for Vena Cava.....625
Foregger, Laryngoscope Blade.....390, 391, 395
Foregger, Laryngoscope Set.....390, 394
Foreign Body Forceps.....794
Foreign Body Instrument.....877
Foreign Body Lever.....872, 877
Förster, Sponge Forceps.....236-237
Foster-Gillies, Needle Holder.....432
Fox, Lupus Curette.....744
Fraenkel, Exchangeable Tip.....938
Frazier, Dura Hook.....697
Frazier, Suction Cannula.....360-361
Freeman, Face-lift Scissors.....748
Freeman-Kaye, Face-lift Scissors.....748
Freer, Mucosa Hooklet.....922
Freer, Mucosa Knife.....906
Freer, Septum Chisel.....911
Freer, Septum Elevator.....907-908
Freer, Septum Gouge.....911
Freer, Septum Knife.....906
French, Tuning Fork.....866
Friedmann, Bone Rongeur.....536
Fritsch, Retractor.....272
Frontal Sinus Dilator.....926
Frosch, Bone Holding Forceps.....527
Frykholm, Bone Rongeur.....542
Fuller, Introducing Forceps.....858

G

Galea hook.....686
Gall Duct Dilator.....781
Gall Stone Curette.....784
Gall Stone Forceps.....782-783
Gallaher, Antrum Rasp.....917
Gardner, Bone Chisel.....464
Gauge.....794
Gauze Packer.....934
Gellhorn, Uterine Biopsy Forceps.....826
Gelpi, Wound Spreaders, self-retaining.....323
Gemini, Dissecting and Ligature Forceps.....207
Gerald, Atraumatic Dressing Forceps.....148
Gerald, Dissecting Forceps.....143, 154
Gerald, Dressing Forceps.....142
Giertz-Stille, Rib Shear.....555
Gigli, Wire Saw.....682
Gigli, Wire Saw Handle.....682
Gillies, Dissecting Forceps.....143, 152
Gillies, Needle Holder.....417, 432
Gillies, Skin Hooklet.....745
Gillies-Mini, Needle Holder.....432
Gil-Vernet, Saddle Hook.....247
Glabella Rasp.....918
Glover, Anastomosis Clamp.....631
Glover, Bulldog Clamp.....592, 612
Glover, Multi purpose Vascular Clamp.....640
Gluck, Rib Shear.....554

Goelet, Retractor.....297
Goitre Enucleator.....742
Goitre Grasping Forceps.....742
Goldman-Fox, Gum Scissors.....99
Goldmann-Fox, Ligature Scissors.....99
Goldsmith (Thudichum), Nasal Speculum.....884
Good, Tonsil Scissors.....93
Goodell, Uterine Dilator.....811
Gorney, Face-lift Scissors.....57, 131, 748
Gosset, Abdominal Retractor.....330-331
Gosset-Baby, Abdominal Retractor.....330
Gouge Blade.....470
Graefe, Iris Scissors.....104
Graefe, Micro Hooklet.....240
Graham, Dura Hook.....696
Graig, Septum Forceps.....891
Grant, Aortic Clamp.....607
grasping forceps.....704
Grave, Vaginal Speculum.....799
Green-Armytage, Uterine Clamp.....840
Greene, Uterine Curette.....834
Gregory, Bulldog Clamp.....593
Gregory, Face-lift Scissors.....747
Gregory, Micro Needle Holder.....420
Gregory, Profunda Clamp.....598
Gregory, soft, Bulldog Clamp.....593
Groningen, Nerve Hook.....695
Grooved Director.....347
Gross, Ear Scoop/Hook.....877
Gross-Maier, Dressing Forceps.....234, 446-447
Grünwald (Jansen), Nasal Tampon Forceps.....890
Grünwald, Ear Forceps.....871
Grünwald, Nasal Tampon Forceps.....890
Grünwald, Rubber Bulb.....880
Guedel-Negus, Laryngoscope Blade.....388
Guedel-Negus, Laryngoscope Set.....388
Guide Support.....916
Guilen, Suction Respiratory.....926
Gum Scissors.....99, 101-102
Gunnar-Hey, Tube milking roller.....230
Guthrie, Skin Hook.....241
Guttmann, Vaginal Speculum.....799
Guyon, Kidney Pedicle Clamp.....214-215
Guyon, Urethral Sound.....790
Gynecological Scissors.....40-41, 44-46

H

Haberer, Abdominal Spatula.....344
Hach, Fasciotomy Spatula.....669
Haemostatic Forceps.....182-199, 218,
.....446-447, 594, 638
Haight, Rib Retractor.....562
Hajek, Sphenoid Bone Punch.....901
Hajek-Kofler, Sphenoid Bone Punch.....901
Halle, Bone Curette.....495
Halle, Septum Elevator.....907
Halsey, Needle Holder.....412, 424
Halsted-Mosquito,
Haemostatic Forceps.....186-187, 446-447
Hand and Nail Brush.....948
Handle.....351, 367
Handle for Vaginal Speculum.....807, 808
Handle, T-form.....350
Hank, Uterine Dilator.....815
Harken, Auricle Clamp.....629
Harrington, Retractor.....285
Hartmann, Bone Rongeur.....537
Hartmann, Ear Catheter.....870
Hartmann, Ear Hooklet.....877
Hartmann, Ear Polypus Forceps.....872-873
Hartmann, Ear Specula, Set.....864
Hartmann, Ear Speculum.....864
Hartmann, Haemostatic Forceps.....186
Hartmann, Nasal Cutting Forceps.....898
Hartmann, Nasal Polypus Forceps.....890
Hartmann, Tonsil Punch.....937
Hartmann, Tuning Fork.....866-868
Hartmann, Wound Spreaders,
self-retaining.....311
Hartmann-Halle, Nasal Speculum.....884

Hartmann-Herzfeld, Ear Polypus Forceps873
Hartmann-Hoffman, Ear Polypus Forceps873
Hartmann-Wullstein, Ear Polypus Forceps.....873
Hayes, Sigmoid Anastomosis Forceps771
Head Band952
Heaney, Hysterectomy Forceps219
Heaney, Needle Holder414, 426
Hegar, Needle Holder429
Hegar, Uterine Dilator812-814
Hegar, Uterine Dilators, Set812
Heggar-Baumgartner, Needle Holder413, 424
Hegar-Vascular, Needle Holder.....429
Heigenbarth, Clip Applying Forceps444
Heifetz, grasping forceps.....702
Heifetz, Spatula694
Heiming, Kidney Stone Forceps780
Heiss, Dissecting and Ligature Forceps201
Hemorrhoidal Grasping Forceps777
Hemorrhoidal Ligator776
Henckel-Tilley, Nasal Forceps870
Henke, Tonsil Elevator934
Henley, Central Blade312
Henley, Wound Spreaders, self-retaining.....312
Henly, Catheter Clamp604
Hennig, Plaster Spreader456
Heparin Flushing Needle.....376, 379
Hepp-Scheidel, Micro Needle Holder419
Hepp-Scheidel, Tubal forceps159
Heymann, Nasal Scissors96
Heywood-Smith, Uterine Polypus Forceps821
Hibbs, Chisel480
Hibbs, Gouge481
Hibbs, Osteotome.....480-481
Hohenfellner, Dissecting Scissors.....61
Hohman, mini, Bone Lever.....514
Hohmann, Bone Lever515-517
Hoke, Osteotome480
Hook341
Hooklet241-245, 248-249, 446-447
Hopkins, Plaster Knife.....455
Hösel, Retractor270
Hospital Nurse Set950
House, Micro Curette.....863
House, Micro Measuring Rod863
House, Suction Tube.....369
House-Dieter, Malleus Nipper857
Howarth, Septum Elevator.....909
Huber, Universal Handle830
Humby, Dermatome17
Humby, Spare Blade17
Hunt, grasping forceps.....703
Hunter, Splinter Forceps168
Hurd, Tonsil Dissector/Retractor.....933
Husfeldt, Peripheral Vascular Clamp603
Hypodermic Syringe381, 882
Hysterectomy Forceps219-220, 222-223
Hysterectomy Scissors132-133

I

Iliac Clamp658
Incision Scissors33
Inductive Accumulator399, 400
Inductive Accumulator Handle.....392, 394,
.....396, 399
Inductive Charger400
Inge, Bone Separator710
Inge, Lamina Spreader.....710-711
Instrument Box812, 964
Insufflation Cannula378
Insulin Syringe.....382
Interchangeable Tube830
Interior Box.....958
Intestinal Anastomosis Clamp.....760, 762
Intestinal and Pylorus Clamp.....759
Intestinal and Tissue Grasping Forceps...750-754
Intestinal Clamp754-758, 766-770
Intima Spatula670
Introducing Forceps.....858
Iowa, Uterine Tenaculum Forceps819
Iris Scissors103-107

Irrigation adapter.....883
Israel, Retractor257
Iterson, Tracheal Hook741
IUP Grasping Forceps830
Ives-Fansler, Anoscope774

J

JABOMA, Dissecting Forceps.....147
JABOMA, Dressing Forceps147
JABOMA, Micro Needle Holder419
JABOMA, Micro Scissors117
Jackson, Tracheal Hook.....741
Jackson, Vaginal Speculum800
Jacobs, Uterine Tenaculum Forceps819
Jacobson, Bone Curette496
Jacobson, Micro Needle Holder.....701
Jacobson, Micro Scissors114, 698
Jacobson, Micro vascular knife705
Jacobson, Probe.....708
Jameson, Dissecting Scissors77
Jamieson, Suction Tube372
Jamison, Needle Holder415
Janet, Spare Barrel384
Janet, Wound and Bladder Syringes384
Jansen, Bone Rongeur537
Jansen, Ear Forceps871
Jansen, Ear Scoop877
Jansen, Periosteal Elevator.....500
Jansen, Wound Spreaders, self-retaining.....300
Javid, Carotid Shunt Clamp599
Jeweler mod., Micro dilating Forceps162
Jeweler mod., Micro Forceps162
Jeweler Type Forceps156
Johns-Hopkins, Bulldog Clamp177
Johnson, Needle Holder416
Joll, Thyroid and Vaginal retractor323
Jones, Towel Clamp226
Jones-Martin, Towel Clamp.....226
Joseph, Bone File.....917
Joseph, Dissecting Scissors.....73-74
Joseph, Mucosa Hooklet921-922
Joseph, Nasal Saw915
Joseph, Operating Scissors.....73,74
Joseph, Periosteal Elevator.....910
Joseph, Rhinoplastic Knife.....905
Joseph, Septum Elevator.....907
Joseph-Masing, Periosteal Elevator910
Jud-Allis, Intestinal and
Tissue Grasping Forceps.....751
Judd-Masson, Bladder Retractor788
Jurasz, Laryngeal Polypus Forceps942

K

Kabierske, Atomizer.....880
Kabierske, Ear Cannula880
Kabierske, Spare Bottle880
Kabierske, Valve Rubber Bulb.....880
Kader, Abdominal Spatula.....293
Kahre-Williger, Periosteal Elevator.....505
Kallmorgen, Vaginal Retractor.....805
Kallmorgen, Vaginal Speculum805
Kalt, Needle Holder.....408
Katsch, Comedone Extractor.....746
Kaye, Face-lift Hooklet745
Kaye, Face-lift Scissors.....57, 119, 747
Kaye, Scalpel Handle9
Kaye-Millard, Hooklet248
Kelly, Dissecting and Ligature Forceps217
Kelly, Haemostatic Forceps189
Kelly, Operating Scissors.....42-43
Kelly, Retractor268, 291
Kelly, Sphincteroscope.....776
Kelly, Uterine Polypus Forceps821
Kelly-Rankin, Haemostatic Forceps190
Kern, Bone Holding Forceps529
Kerrison, Antrum Punch.....904
Kerrison, Laminectomy Punch712-723
Kevorkian, Uterine Biopsy Curette.....825
Kevorkian, Uterine Biopsy Forceps829
Key470

Key for Approximator174
Key, Periosteal Elevator.....503
Keyes, Dermal Punch745
Kidney Dish965
Kidney Pedicle Clamp.....214-215
Kidney Stone Forceps780
Kielland, Obstetrical Forceps.....839
Kielland-Luikart, Obstetrical Forceps.....839
Killian, Nasal Speculum885
Killian, Septum Elevator909
Killian, Septum Gouge.....911
Killian-Claus, Septum Gouge.....911
Kilner, Alar Hooklet922
Kilner, Dissecting Scissors76
Kilner, Needle Holder423
Kilner, Skin Hooklet745
Kirschner, Abdominal Retractor337-338
Kirschner, Blade337-339
Kirschner, Frame.....337-339
Kirschner, Ligature Conductor441-442
Klapp, Retractor.....249
KLING-EX, Scalpel Blade Remover10
Knee Retractor.....519
Knight, Septum Forceps891
Knot Tier443
Knowles, Bandage Scissors450
Knurled screw869
Knutson, Urethrography Instrument793
Knutson-Koch, Cone.....793
Kocher (Ochsner), Haemostatic Forceps .198-199
Kocher, Goitre Enucleator742
Kocher, Haemostatic Forceps194, 446-447
Kocher, Intestinal Clamp757-758, 768-769
Kocher, Retractor253, 262, 266, 273
Kocher-Langenbeck, Retractor.....263-264
Kocher-Nippon, Haemostatic Forceps.....194
Koenig, Periosteal Elevator.....500
Kogan, Endocervical Speculum.....811
König, Ligature Conductor442
König, Tuning Fork869
Koos, Micro vascular knife705
Körte, Retractor256
Krause, Exchangeable Tip939
Krause, Polypus Snare870, 888
Krause-Voss, Polypus Snare.....870, 888
Krayenbühl, Nerve and Vessel Hooklet.....709
Krenkel, Cleft Palate Periosteal Rasapatory...907
Kressner, Septum Forceps.....924
Kristeller, Vaginal Retractor801-804
Kristeller, Vaginal Speculum.....801-804
Kronecker, Ligature Needle437

L

La Grange, Gum Scissors101
Laborde, Tracheal Dilator740
Lahey, Bile Duct Clamp.....213
Lahey, Goitre Grasping Forceps.....742
Lahey, Retractor261
Lambert-Kay, Anastomosis Clamp632
Lambert-Kay, Multi purpose Vascular Clamp..654
Lambotte, Osteotome475-476
Lambotte, Periosteal Elevator508
Lambotte-Mini, Osteotome474
Lamina Spreader710-711
Laminectomy Punch712-723
Laminectomy Retractor340
Laminectomy Rongeurs.....724-731
Landolt, Periosteal Elevator500
Landolt, Suction Tube.....365
Landolt, Tumor Grasping Forceps.....732
Lane, Bone Holding Forceps.....533
Lane, Stomach and Intestinal
Anastomosis Twin Clamp.....763-764
Lane, Towel Clamp228
Lange, Alar Hooklet921
Lange, Exchangeable Tip.....938
Lange-Hohmann, Bone Lever.....517
Langenbeck, Bone Holding Forceps527
Langenbeck, Ear Curette.....876
Langenbeck, Elevator.....512

- Langenbeck, Needle Holder.....434
 Langenbeck, Periosteal Elevator.....500
 Langenbeck, Resection Knife15
 Langenbeck, Retractor.....258-260
 Langenbeck-Green, Retractor260
 Langenbeck-Mini, Hooklet.....243
 Laryngeal Mirror.....940-941
 Laryngeal Mirror Handle.....941
 Laryngeal Polypus Forceps942
 Laryngeal Tube.....937, 938, 939
 Laryngoscope Blade387-392-393, 395-397
 Laryngoscope Set387-390, 392, 394, 396
 Lateral Blade.....324-329, 558, 565-571,
573-574, 577-582
 Lawrence, Dissecting and Ligature Forceps.....218
 Lazar, Micro Tying Forceps167
 Lebsche, Sternum Chisel556
 Lees, Bronchus Clamp630
 Leksell-Stillé, Bone Rongeur542
 Leland-Jones, Peripheral Vascular Clamp.....617
 Lempert, Bone Rongeur537
 Lempert, Ear Scoop879
 Lempert, Micro Ear Periosteal Elevator.....879
 Leriche, Haemostatic Forceps.....188
 Lewin, Bone Holding Forceps526
 Lewis, Nasal Rasp918
 Lexer, Dissecting Scissors58, 60, 127
 Lexer, Gouge.....473
 Lexer, Osteotome.....473
 Lexer, Spongiosa Gouge471
 Lexer-Baby, Dissecting Scissors64
 Lexer-Fino, Delicate Dissecting Scissors65
 Lexer-Mini, Gouge472
 Lexer-Mini, Osteotome472
 Leyla, Ball Socket Joint692, 693
 Leyla, Brain Spatula690
 Leyla, Coupling head691-693
 Leyla, Fixation device691
 Leyla, Holding Rod692, 693
 Leyla, Support with round shaft.....691-692
 Lichtenberg, Needle Holder.....418, 434
 Lid for Kidney Dishes965
 Lid, waste bucket.....974
 Ligature Carrying Forceps.....787
 Ligature Catcher.....443, 671
 Ligature Conductor.....440-443
 Ligature Forceps.....185-186, 615, 622-623
 Ligature Fork443, 705
 Ligature Needle436-440
 Lillehei-Potts, Dissecting Scissors.....123
 Lister, Bandage Scissors450, 454
 Lister, Sinus Forceps233
 Liston, Bone Cutting Forceps.....545
 Liston-Key, Bone Cutting Forceps549
 Littauer, Cilia Forceps169
 Littauer, Stitch Scissors120
 Little, Retractor.....261
 Liver Forceps626
 Liver Puncture Needle379
 Loading Cone.....776
 Lockhart-Mummery, Fistula Probe.....347
 Locking Device.....762
 Locklin, Gum Scissors102
 Lockwood, Intestinal and
 Tissue Grasping Forceps.....751
 Logan, Wound Spreaders, self-retaining.....299
 Loop retainer870
 Lorenz, Bandage Scissors.....450
 Lorna, Towel Clamp227
 Lovelace, Haemostatic Forceps.....191
 Lovelace, Lung Grasping Forceps590
 Lower, Dissecting and Ligature Forceps213
 Lubet-Barbon, Nasal Tampon Forceps890
 Lucae, Ear Hooklet.....877
 Lucae, Mallet.....485
 Lucae, Tuning Fork.....868
 Lucae, Tympanum Needle878
 Luer Adaptor.....668
 Luer, Bone Rongeur.....539
 Luer, Suction Tube360, 364
 Luer, Tracheal Hook.....741
 Lukens, Thymus Retractor.....741
 Lumbar Puncture Needle377
 Lung Grasping Forceps590
 Lung Spatula586
 Luniatschek, Gauze Packer934
 Lupus Curette.....744
 Lupus Scraper.....744
- M**
- M. G. Hospital, Needle Holder.....414
 Magill, Catheter Introducing Forceps.....386
 Mallet484-489
 Malleus Nipper857
 Maltz, Nasal Rasp917, 919
 Manometer for Salpingograph.....835
 Marquard, Bone Rongeur540
 Martel-Rees, Face-lift Forceps185
 Martin Aquajet, Water Jet Pistol.....968
 Martin Arm System.....342
 Martin, Abdominal Spatula.....344
 Martin, Brush Dispenser948
 Martin, Cartilage Seizing Forceps.....526
 Martin, Dressing Forceps.....233
 Martin, Luer Adaptor668
 Martin, Martin Arm System342
 Martin, Nasal Speculum885
 Martin, Needle Holder427
 Martin, Optics mounting342
 Martin, Pelvimeter838
 Martin, Peripheral Vascular Clamp600
 Martin, Plaster Knife455
 Martin, Retractor.....254, 274
 Martin, Screw Olive668
 Martin, Tuning Fork867
 Martin, Tunneling Set668
 Martin, Tunneling Shaft668
 Martin, Universal Fixation Clamp342, 343
 Martin, Universal Handle668
 Martin, Vascular Measuring Caliper604
 Martin, Vein Tip.....668
 Martin, Waste Forceps974
 Martin, Wound Spreaders, self-retaining.....321
 Martin, Wrench668
 Martin-Alloy, Tuning Fork867
 Martin-Aquajet, Cleansing Tip.....972-973
 Martin-Aseptich, Hand and Nail Brush948
 Martin-Cushing, Periosteal Elevator.....499
 Martin-Fuchsfig, Dissecting and
 Ligature Forceps192
 Martin-Hoen, Periosteal Elevator.....498
 Martini, Needle Holder430-431
 Martin-Langenbeck, Elevator512
 Martin-Langenbeck, Periosteal Elevator498
 Martin-Rochard, Cross Bar343
 Martin-Rochard, Fixation Arm.....343
 Martin-Rochard, Fixing device for hooks343
 Martin-Rochard, Retractor.....343
 Martin-Rochard, Retractor System343
 Martin-Rochard, Sliding Clamp.....343
 Masing, Periosteal Elevator910
 Masson, Needle Holder415, 426
 Mastoid Rongeur874-875
 Mathieu, Foreign Body Forceps.....794
 Mathieu, Needle Holder.....417-418, 432-433
 Mathieu, Retractor297
 Mayfield, Bone Rongeur.....540
 Mayo, Dissecting Forceps.....34-35, 158
 Mayo, Dissecting Scissors34-35
 Mayo, Safety Pin960
 Mayo-Blake, Gall Stone Forceps.....782
 Mayo-Harrington, Dissecting Scissors39
 Mayo-Hegar, Needle Holder.....414, 425
 Mayo-Lexer TCC-BlackLine,
 Dissecting Scissors.....59
 Mayo-Lexer, Dissecting Scissors.....127
 Mayo-Lexer-Aquila, Dissecting Scissors59
 Mayo-Noble, Dissecting Scissors39
 Mayo-Robson, Intestinal Clamp756, 767
 Mayo-Stillé, Dissecting Scissors.....36-38
 Mayo-Stillé, Operating Scissors.....36-37
 McDonald, Dissector, double-ended513
 McGee, Micro Ear Hook861
 McGee, Wire Bending Forceps856
 McGinvey, Hemorrhoidal
 Grasping Forceps777
 McIndoe, Dressing Forceps140, 143
 McIndoe, Neurosurgical Scissors92
 McIntosh, Laryngoscope Blade392-393
 McIntosh, Laryngoscope Set.....389, 392
 McKenty, Septum Elevator.....907-908
 McKenzie, Clip Applying Forceps.....685
 McQuigg-Mixter, Dissecting and
 Ligature Forceps212
 Mead, Bone Rongeur537
 Mead, Mallet486
 Measurer962
 Meatotome794
 Meeker, Dissecting and Ligature Forceps218
 Menghini, Liver Puncture Needle379
 Meniscus Knife520
 Metal Catheter, female.....791
 Metal Jar964
 Metal Olive882
 Metzenbaum, Dissecting Scissors
47-48, 50-54, 56, 67, 70, 446-447
 Metzenbaum, Needle Holder413
 Metzenbaum-Aquila, Dissecting Scissors49, 55
 Metzenbaum-Aquila-Fino,
 Dissecting Scissors.....67, 70
 Metzenbaum-Fino, Delicate Dissecting
 Scissors66-71, 128, 130
 Metzenbaum-Lahey, Dissecting Scissors128
 Metzenbaum-Nelson, Dissecting Scissors52-54
 Metzenbaum-TCC-BlackLine,
 Dissecting Scissors.....49, 55
 Metzenbaum-TCC-BlackLine-Fino,
 Dissecting Scissors.....126
 Metzenbaum-Thorek, Dissecting Scissors.....127
 Meyerding, Hooklet244
 Michel, Clip Applying Forceps444
 Michel, Laryngeal Mirror941
 Michel, Suture Clip445
 Micro Curette.....708, 863
 Micro dilating Forceps162
 Micro Dissecting Scissors.....116, 699
 Micro Dissector349, 705, 707, 862
 Micro Ear Forceps848-853
 Micro Ear Hook860-862
 Micro Ear Needle860-861
 Micro Ear Periosteal Elevator.....862, 879
 Micro Ear Scissors.....854-855
 Micro Forceps.....141, 153, 161-163, 165, 702
 Micro Forceps with counterbalance162, 164
 Micro Hooklet240, 708
 Micro Measuring Rod863
 Micro Needle Holder404-411, 418-423, 701
 Micro Periosteal Elevator.....706
 Micro Phlebextractor.....349
 Micro Ring Forceps162-163, 165
 Micro Scissors79, 111-117, 698-700
 Micro scissors for veins.....116
 Micro Tying Forceps.....167
 Micro vascular knife705
 Microscopic Forceps.....168
 Microvascular, Needle Holder430
 Middeldorpf, Retractor.....267, 271
 Middle part with ball880
 Middleton-Jansen, Septum Forceps.....899
 Mikro-Adson, Dissecting Forceps155
 Mikro-Adson, Dressing Forceps155
 Mikro-Adson, Haemostatic Forceps185
 Mikro-Friedman, Bone Rongeur538
 Mikro-Hegemann, Coronary Scissors.....82
 Mikro-Mosquito, Haemostatic Forceps188
 Mikulicz, Peritoneum Forceps.....224-225
 Mikulicz, Retractor291
 Mikulicz, Retractor290
 Mikulicz-Baby, Peritoneum Forceps.....224
 Miller, Alveotomy File511

Miller, Laryngoscope Blade387, 396-397
 Miller, Laryngoscope Set387, 396
 Miller-Baby, Laryngoscope Set387
 Miller-Colburn, Bone File510-511
 Millesi, Micro Scissors698
 Milligan, Dura Dissector688
 Milligan, Wound Spreaders, self-retaining311
 Millin, Bladder Neck Spreader788
 Millin, Bladder Retractor789
 Millin, Capsule Forceps786-787
 Millin, Ligature Carrying Forceps787
 Mini Glover, Dissecting and
 Ligature Forceps181
 Mini Phlebextractor349
 Mini Vessel Clip175
 Mini-Adson, Dissecting Forceps155
 Mini-Gemini, Dissecting and
 Ligature Forceps207
 Mini-McGee, Micro Ear Forceps849
 Mixer, Dissecting and
 Ligature Forceps210-212
 Mixer, Gall Stone Forceps783
 Mixer-Baby, Dissecting and
 Ligature Forceps185, 201, 209
 Mixer-O'Shaughnessy, Dissecting
 and Ligature Forceps210
 Mock, Heparin Flushing Needle376, 379
 Mod. Bonn, Iris Scissors104
 Mod. Martin, Dressing Forceps in jar,
 with cap960
 Mod. Martin, Face Protection Mask952
 Mod. Martin, Ligature Conductor441
 Mod. München, Uterine Biopsy Curette825
 Mod. USA, Umbilical Scissors98
 Mod. Wien, Nasal Speculum886
 Modell USA, Bone Curette494-495
 Modell Wien, Ligature Catcher443
 Mogen, Circumcision Instrument793
 Moldenhauer, Foreign Body Lever877
 Mollison, Wound Spreaders, self-retaining308
 Molt, Bone Curette497
 Molt, Bone Curette, double-ended497
 Morris-De Bakey, Aortic Clamp633
 Morse, Sternal Retractor563
 Morse-Favaloro, Sternal Retractor562
 Moynihan, Hysterectomy Forceps222
 Mucosa Hooklet921-922
 Mucosa Knife906
 Mucosa Knife859
 Muehling, Periosteal Elevator502
 Mueller, Vessel Clip179
 Müller, Approximator172-173
 Multi purpose Vascular Clamp596, 618,
 635-637, 639-642, 647-648,
 650-654, 659-664
 Museux, Uterine Tenaculum Forceps819
 Myoma Knife822
 Myoma Screw822
 Myrtle Leaf Probe346

N

Nabatoff, Handle, T-form350
 Nabatoff, Olive350
 Nabatoff, Plastic Probe Tip350
 Nabatoff, Traction Cable350
 Nabatoff, Varicose Vein Probe Set350
 Nagel, Micro Scissors700
 Nägele, Obstetrical Forceps838
 Nail File951
 Nail Nipper950, 951
 Nail Scissors950
 Nasal Cutting Forceps893-894, 896, 898
 Nasal Forceps870
 Nasal Hook921
 Nasal Polypus Forceps890
 Nasal Rasp917-920
 Nasal Retractor921-923
 Nasal Saw915
 Nasal Scissors63, 95-96
 Nasal Speculum884-887

Nasal Tampon Forceps890
 Needle Case961-963
 Needle Holder408, 411-420,
 422-434, 436, 446-447
 Needle Tray959
 Neff, Meniscus Knife520
 Negus, Haemostatic Forceps218
 Neivert, Alar Hooklet923
 Neivert, Needle Holder412
 Neivert-Anderson, Osteotome914
 Nelaton, Grooved Director347
 Nelson, Dissecting Forceps159
 Nelson, Trocar358
 Neonatal Vascular Clamp675, 677
 Nerve and Vessel Hooklet709
 Nerve Approximator174
 Nerve Dissecting Scissors56
 Nerve Hook695
 Nerve Hooklet671
 Neuro, Tuning Fork869
 Neurosurgical Scissors90, 92
 Norfolk-Norwich, Wound Spreaders,
 self-retaining302
 Northbert, Stitch Scissors119
 Nose Olive881
 Noto, Uterine Polypus Forceps821
 Novak, Suction Curette825
 Nuboer, Suction Tube372

O

Obstetrical Forceps838-839
 Obstetrical Lever840
 Obturator926
 Ochsner, Aortic Clamp595
 O'Connor, Skin Hook241
 Oehler, Dissecting Forceps146
 Ogura, Skin Grasping Forceps925
 Oldberg, Pituitary Rongeur732
 Olive348, 350, 367
 Olivecrona, Dura Dissector686-687
 Olivecrona, Trigeminal Scissors92
 Olivecrona-Tönnis, Clip Applying Forceps685
 Ollier, Retractor255
 Olsen-Hegar, Needle Holder417, 431
 Operating Scissors20, 22, 24, 26, 28,
 30-37, 42-43, 73-74, 78,
 100, 103, 108-109, 446-447
 342
 Organ Grasping Forceps183-184, 765
 Oscillating Plaster Saw458
 O'Shaughnessy, Dissecting and
 Ligature Forceps210
 Osteotome465, 468-469, 472-477,
 480-481, 912-914
 Osteotome Blade470
 O'Sullivan-O'Connor, Abdominal Retractor336
 Otis, Spare Blade792
 Otis, Urethrotome792
 Overholt-Baby, Dissecting and
 Ligature Forceps190
 Overholt-Fino, Dissecting and
 Ligature Forceps205-206
 Overholt-Geissendörfer, Dissecting
 and Ligature Forceps204
 Overholt-Martin, Dissecting and
 Ligature Forceps200
 Overholt-Mini, Dissecting and
 Ligature Forceps206
 Overholt-Mixer, Dissecting and
 Ligature Forceps201

P

Papavero-Caspar, Pituitary specula733
 Parker, Retractor296
 Parker-Langenbeck, Retractor297
 Parker-Mott, Retractor296
 Parkes, Osteotome914
 Partsch, Chisel466
 Partsch, Gouge466
 Partsch, Mallet486

Payr, Intestinal and Pylorus Clamp759
 Payr, Ligature Conductor443
 Payr-Baby, Intestinal and Pylorus Clamp759
 Pean (Rochester),
 Haemostatic Forceps196-197
 Pean, Haemostatic Forceps182, 193,
 446-447
 Pean-Nippon, Haemostatic Forceps193
 Peck-Joseph, Face-lift Scissors75
 Pederson, Vaginal Speculum799
 Pediatric Vascular Clamp643-646, 649,
 657, 673-676
 Peers-Bertram modif., Towel Clamp227
 Peers-Bertram, Towel Clamp228
 Peet, Splinter Forceps170
 Pelvimeter838
 Pelvis Retractor292-293
 Penfield, Dura Dissector689
 Penis Clamp795
 Pennington, Haemostatic Forceps184
 Pennington, Septum Elevator910
 Percy, Amputation Retractor535
 Periosteal Elevator498-506, 508, 910
 Peripheral Vascular Clamp597, 600,
 603, 616-617
 Peritoneum Forceps224-225
 Pestalozza, Placenta Scoop842
 Phaneuf, Hysterectomy Forceps219
 Phlebextractor349
 Phlebodissector349
 Pierse, Micro Forceps162
 Pierse, Micro Forceps with counterbalance162
 Piper, Obstetrical Forceps839
 Pittsburgh, Liver Forceps626
 Pituitary Rongeur731-732
 Pituitary specula733
 Placenta and Ovum Forceps840
 Placenta Scoop841, 842
 Plaster Breaker457
 Plaster Knife455
 Plaster Shears451-454
 Plaster Spreader456
 Plastic Probe Tip350
 Plester, Flap Knife859
 Plester, Suction Cannula378
 Plester, Wound Spreaders, self-retaining309
 Politzer, Air Bag881
 Politzer, Connecting Nozzle881
 Politzer, Ear Olive881
 Politzer, Nose Olive881
 Politzer, Rubber Bulb881
 Politzer, Tympanum Lancet878
 Politzer, Tympanum Needle878
 Polloson, Retractor283, 284
 Polypus Snare870, 888
 Poole, Suction Tube368
 Poppen, Suction Cannula362
 Potts, Anastomosis Clamp615
 Potts, Coarctation Clamp613-614
 Potts, Micro Scissors114
 Potts, Multi purpose Vascular Clamp635
 Potts-De Martell-Highmed,
 Dissecting Scissors123
 Potts-Smith, Dissecting Forceps154
 Potts-Smith, Dressing Forceps142, 145
 Potts-Smith, Vascular Scissors83
 Pratt, Haemostatic Forceps184
 Pratt, Rectal Speculum774
 Price-Thomas, Bronchus Clamp587
 Probe346, 708
 Probe845
 Profunda Clamp598
 Prostatic Retractor785
 Protecting Disc882
 Protecting Shield952
 Protection Cap900
 Protection Spectacle952
 Providence-Hospital, Haemostatic Forceps188
 Pudendus Anaesthesia Needle376
 Putti, Bone Rasp482
 Pylorus Spreader761

- Q**
 Quattro, Plaster Spreader456
 Quervain, Elevator513
 Quire, Foreign Body Lever872
- R**
 Ragnell, Dissecting Scissors135
 Ragnell-Davis, Hooklet245
 Ralk, Splinter Forceps170
 Rampley, Sponge Forceps237
 Randall, Kidney Stone Forceps780
 Raney, Applying/Removal Forceps685
 Raney, Scalp Clip685
 Rasse, Bone Hooklet240
 Rasse, Micro Hooklet240
 Razor Blade4
 Razor Knife16
 Recamier, Uterine Curette832
 Record-Arkansas, Sharpening Stone16
 Rectal Biopsy Forceps777
 Rectal Scissors118
 Rectal Speculum774
 Rectal Spreader775
 Redon, Guide Needle374-375
 Rees, Face-lift Scissors131
 Reiner, Plaster Knife455
 Reposition Forceps526, 528
 Resano, Dissecting Forceps159
 Resano, Sigmoid Anastomosis Forceps773
 Resection Knife15
 Retention spring882
 Retractor249-275, 277-280,
283-291, 294-297, 343
 Retractor System343
 Reverdin, Reverdin Needle435
 Reynolds, Dissecting Scissors77-78
 Reynolds, Operating Scissors78
 Rhinoplastic Chisel914
 Rhinoplastic Knife905
 Rib Contractor584
 Rib Raspatorly507
 Rib Retractor558-568, 573-576
 Rib Shear554-556
 Ricard, Abdominal Retractor327
 Ricard, Central Blade327
 Ricard, Spreader, only327
 Richardson, Retractor268
 Richardson-Eastman, Retractor267
 Richter, Clip Applying Forceps444
 Richter, Laminectomy Rongeurs731
 Ring Stripper351
 Ritter-Halle, Frontal Sinus Dilator926
 Robb, Vascular Dissector670
 Roberts, Dissecting and Ligature Forceps202
 Rochester-Carmalt, Haemostatic Forceps192
 Roeder, Towel Clamp227
 Roger, Septum Elevator910
 Rogers, Hysterectomy Forceps221
 Rose, Tracheal Hook741
 Rosen, Circular Cut Knife859
 Rosen, Micro Ear Needle860
 Rosen, Micro Ear Periosteal Elevator862
 Rosenberg, Exchangeable Tip939
 Ross, Aorta Retractor281-282
 Round Bowl962
 Round Metal Box965
 Roux, Retractor294
 Roux-Baby, Retractor295
 Roux-Mini, Retractor295
 Rubber Bulb880, 881
 Rubber gasket882
 Rubber Ring776
 Rubin, Osteotome913
 Rubin, Protection Cap900
 Rubin, Septum Morselizer900
 Rudd, Hemorrhoidal Ligator776
 Rudd, Loading Cone776
 Rumel, Dissecting and Ligature Forceps208
 Rumel-Belmont, Tourniquet671
 Ruskin, Bone Rongeur540
 Ruskin-Liston, Bone Cutting Forceps547
 Russ. Modell, Dissecting Forceps157
 Rydel-Seiffert, Tuning Fork869
 Ryder (Martin), Needle Holder427
 Ryder-Vascular, Needle Holder428
- S**
 Saalfeld, Comedone Extractor746
 Sachs, Dura Dissector687
 Sachs, Dura Hook696-697
 Sachse, Gauge794
 Sachse, Meatotome794
 Saddle Hook243, 246-247, 923
 Safety Pin960
 Salenius, Meniscus Knife520
 Salpingograph835
 Salyer, Cleft Palate Dissector932
 Salyer, Cleft Palate Elevator932
 Salyer, Cleft Palate Hooklet932
 Salyer, Dissecting Scissors72, 119
 Samii, grasping forceps702
 Samii, Micro vascular knife705
 Samii, Tumor knife704
 Sanger, Placenta and Ovum Forceps840
 Santulli, Bulldog Clamp592
 Sanvenero, Operating Scissors72
 Sarot, Dissecting and Ligature Forceps202
 Sarot, Needle Holder425
 Satinsky, Tangential Occlusion Clamp628
 Satinsky, Vascular Clamp627
 Satinsky, Vascular Scissors80
 Sauerbruch, Bone Rongeur544
 Sauerbruch, Needle Case957
 Sauerbruch, Retractor277, 280
 Sauerbruch, Rib Shear555
 Sauerbruch, Waste Forceps974
 Saw Blade10, 458
 Scalp Clip685
 Scalp-Contour, Wound Spreaders,
 self-retaining301
 Scalpel Blade Remover10
 Scalpel Blade, non-sterile10-11
 Scalpel Handle5-9, 12, 446-447
 Scapula Retractor276
 Schadel, Towel Clamp226
 Schamberg, Comedone Extractor746
 Schede, Bone Curette491
 Scheibe, Organ Grasping Forceps765
 Scheinmann, Exchangeable Tip938
 Scherbak, Handle for
 Vaginal Speculum807, 808
 Scherbak, Specula Blade, only807
 Scherbak, Vaginal Speculum808
 Scherbak, Weight for Vaginal Speculum808
 Schink, Dermatome17
 Schink, Skin Fixing Plate17
 Schink, Spare Blade17
 Schmeden, Nasal Cutting Forceps898
 Schmid, Vessel Irrigation Cannula379
 Schmieden, Ligature Conductor442
 Schmieden, Ligature Needle436
 Schmieden-Dick, Ligature Needle436
 Schmieden-Payr, Ligature Conductor442
 Schmieden-Taylor, Dura Scissors90
 Schneider, Periosteal Elevator501
 Schnidt, Dissecting and Ligature Forceps192
 Schnidt, Tonsil Forceps935
 Schroder, Uterine Tenaculum Forceps817-818
 Schubert, Uterine Biopsy Forceps826-827
 Schuhmacher, Umbilical Scissors98
 Schuknecht, Sickle Knife859
 Schultze, Manometer for Salpingograph835
 Schultze, Salpingograph835
 Schumacher, Exchangeable Tip939
 Schumacher, Tip only830
 Schumacher, Uterine Biopsy Forceps829-830
 Scoville, Blade341
 Scoville, Bone Curette493
 Scoville, Hook341
 Scoville, Laminectomy Retractor340
 Scoville-Haverfield, Laminectomy Retractor340
 Screw521
 Screw Olive668
 Scudder, Intestinal Clamp770
 Sebileau, Elevator513
 Sedillot, Periosteal Elevator501, 504
 Segond, Myoma Knife822
 Seiffert, Exchangeable Tip938
 Sellheim, Obstetrical Lever840
 Sellors, Rib Contractor584
 Semb, Bone Cutting Forceps549
 Semb, Bone Holding Forceps529
 Semb, Bone Rongeur540
 Semb, Bronchus Clamp588
 Semb, Periosteal Elevator508
 Semken, Dissecting Forceps143, 152
 Semken, Dressing Forceps141
 Semm, Vaginal Speculum799
 Senn-Green, Hooklet245
 Senn-Miller, Hooklet245
 Septum Chisel911
 Septum Elevator907-910
 Septum Forceps891, 899, 924
 Septum Gouge911
 Septum Knife906
 Septum Morselizer899-900
 Septum Straightening Forceps924
 Sewall, Periosteal Elevator501
 Shaaf, Splinter Forceps168
 Shambaugh, Micro Ear Hook862
 Shapleigh, Ear Curette876
 Sharpening Stone16
 Shea Vein Graft, Dissecting Scissors75
 Shea, Exploring Hook862
 Sickle Knife859
 Sigmoid Anastomosis Forceps770-773
 Silicone Plate959
 Silver, Dermatome17
 Silver, Rhinoplastic Chisel914
 Simon, Bone Curette493
 Simon, Fistula Hook824
 Simon, Retractor274
 Simon, Uterine Scoop831
 Simpson, Obstetrical Forceps838
 Sims, Gynecological Scissors40-41
 Sims, Rectal Speculum774
 Sims, Uterine Curette832
 Sims, Uterine Sound816
 Sims, Vaginal Speculum800
 Sims-Aquila, Uterine Scissors41
 Sims-Siebold, Gynecological Scissors45
 Sims-TCC-BlackLine, Uterine Scissors41
 Singley-Tuttle, Dissecting Forceps158
 Sinus Forceps233
 Skene, Uterine Tenaculum Forceps818
 Skin Fixing Plate17
 Skin Grasping Forceps925
 Skin Hook240-241, 745
 Skull Breaker464
 Skull Traction Tong683
 Sliding Clamp343
 Small Suture Set446
 Smillie, Meniscus Knife520
 Smith-Petersen, Gouge478
 Smith-Petersen, Osteotome477
 Smithwick, Nerve Hook695
 Snare Wire870, 888, 936
 Snyder-O.S.U., Bone Chisel464
 Socket868
 Somer, Uterine Seizing Forceps823
 Spare Barrel381-384
 Spare Blade17, 453, 792
 Spare Bottle880
 Spare Bulb391, 398
 Spare Button868
 Spare Facings486-488
 Spare Glass949
 Spare Needle174, 436
 Spare Pin683

- Spare Screw470
 Spatula694
 Specula Blade, only807
 Spencer, Stitch Scissors119-120
 Spencer-Wells, Haemostatic Forceps182
 Sphenoid Bone Punch901-903
 Sphincteroscope776
 Spinal Retractor519
 Splinter Forceps166-168, 170
 Sponge Forceps235-237
 Spongiosa Gouge471
 Spratt, Bone Curette492
 Spreader, only327, 337-339, 565-568,
570, 572-574, 579-581
 Spring322
 St. Barts, Ethmoid Bone Forceps895
 St. Marks, Pelvis Retractor292-293
 Stacke, Ear Probe346
 Stainless Steel Bowl962
 Stella-S, Face-lift Scissors747
 Stellbrink, Bone Rongeur536
 Sterilizing Forceps956
 Sternal Retractor563
 Sternotomy Spreader558
 Sternum Chisel556
 Stevens, Operating Scissors108-109
 Stevens, Tendon Scissors108-109
 Stieglitz, Splinter Forceps170
 Stille, Bone Rongeur540
 Stille, Chisel468
 Stille, Dissecting Forceps151
 Stille, Dressing Forceps139
 Stille, Gouge469
 Stille, Osteotome468-469
 Stille-Barraya, Dissecting Forceps157
 Stille-Liston, Bone Cutting Forceps547-548
 Stille-Luer, Bone Rongeur543
 Stille-Martin, Plaster Shears453
 Stille-Ruskin, Bone Rongeur541
 Stitch Scissors119
 Stitch Scissors99, 119-120, 124-125
 Stockmann, Penis Clamp795
 Stomach and Intestinal Anastomosis
 Twin Clamp763-764
 Stone-Watt, Closing Forceps762
 Stone-Watt, Intestinal Anastomosis Clamp762
 Stone-Watt, Locking Device762
 Stopcock380
 Storage Rack for Petri Dishes956
 Storing Cup959
 Strabismus Scissors110
 Strainer for Vaginal Speculum810
 Strandell-Stille, Hooklet248
 Stratte, Needle Holder416, 429-430
 Strauss, Penis Clamp795
 Strully, Neurosurgical Scissors90
 Strümpel, Ear Polypus Forceps873
 Struycken, Nasal Cutting Forceps896
 Subramanian, Aortic Clamp672
 Subramanian-Miniature, Aortic Clamp672
 Suction Cannula348, 360-363,
377-378
 Suction Curette825, 834
 Suction Handle373
 Suction Nozzle882
 Suction Respiratory926
 Suction Tip362, 367, 373
 Suction Tube359, 361, 363-365,
366-369, 370-373
 Support for spatulas690-692
 Support with round shaft691-692
 Suture Clip445
 Suture guide706
 Swivel headed scalpel handle6
 Swivel Knife906
- T**
 Tabb, Mucosa Knife859
 Takahashi, Ethmoid Bone Forceps892
 Tamper483
- Tangential Forceps214
 Tangential Occlusion Clamp628
 Taylor, Dissecting Forceps153
 Taylor, Dressing Forceps141
 Taylor, Hook341
 Taylor, Spinal Retractor519
 Teale, Uterine Tenaculum Forceps818
 Tendon Holding Forceps523, 524
 Tendon Interlacing Forceps524
 Tendon Passer522
 Tendon Passing Instrument521
 Tendon Scissors108-109
 Tendon Stripper521-522
 Tendon Tunnelling Forceps523
 T-Handle916
 Thoms-Allis, Intestinal and Tissue
 Grasping Forceps751
 Thoms-Gaylor, Uterine Biopsy Forceps827
 Thoracic Retractor570, 572, 579-580, 583
 Thorek, Dissecting Scissors63
 Threaded Tip882
 Three-Way Stopcock380
 Thymus Retractor741
 Thyroid and Vaginal retractor323
 Tieck-Halle, Nasal Speculum885
 Tip only830
 Toennis, Dissecting Scissors91
 Toennis, Dura Dissector686
 Toennis, Needle Holder418, 433
 Toennis-Adson, Dissecting Scissors91, 129
 Tohoku, Towel Clamp227, 446-447
 Tönnis-Adson TCC-BlackLine,
 Dissecting Scissors129
 Tönnis-Adson-Aquila, Dissecting Scissors129
 Tonsil Elevator933-934
 Tonsil Forceps935
 Tonsil Grasping Forceps935, 937
 Tonsil Knife933
 Tonsil Knife / Eucleator933
 Tonsil Needle364, 377
 Tonsil Scissors93-94
 Tonsil Snare936
 Tourniquet671
 Towel Clamp226-228, 446-447
 Toynbee, Ear Specula, Set864
 Toynbee, Ear Specula, Set864
 Tracheal Dilator740
 Tracheal Hook741
 Traction Cable350
 Trelat, Periosteal Elevator500
 Trelat, Vaginal Speculum799
 Trigeminal Scissors92
 Triple-ring Syringe382
 Trocar358
 Tröltzsch (Wilde), Ear Forceps871
 Tröltzsch, Nasal Tampon Forceps890
 Trousseau, Tracheal Dilator740
 Troutman-Chris, Blade Holder /
 Blade Breaker4
 Trowel Knife844
 Tubal forceps159
 Tubbs, Aortic Dilator665
 Tube milking roller230
 Tuberculin Syringe383
 Tubing Clamp228-229
 Tuffier, Haemostatic Forceps183
 Tuffier, Rib Retractor563
 tumor forceps702
 Tumor fork704
 Tumor Grasping Forceps184, 732
 Tumor knife704
 Tuning Fork866-869
 Tunneling Forceps234
 Tunneling Set668
 Tunneling Shaft668
 Tuohy, Lumbar Puncture Needle377
 Turnbull, Nail Nipper950
 Tyding, Tonsil Snare936
 Tympanum Lancet878
- U**
 Ulrich, Bone Holding Forceps531
 Ulrich, Dressing Forceps232
 Umbilical Cord Clamp842
 Umbilical Scissors98
 Universal Fixation Clamp342, 343
 Universal Handle668, 830
 Universal Tray963
 Universal, Atomizer880
 Universal, Bandage Scissors452
 Universal, Trocar358
 Universal, Wire Cutting Scissors121
 Unna, Comedone Extractor746
 Unna-Vidal, Comedone Extractor746
 Urethral Olive380
 Urethral Sound790
 Urethrography Instrument793
 Urethrotome792
 Uterine Biopsy Curette825
 Uterine Biopsy Forceps826-830
 Uterine Clamp840
 Uterine Depressor816
 Uterine Dilator811-815
 Uterine Dilators, Set812
 Uterine Polypus Forceps821
 Uterine Scoop831-832, 834
 Uterine Seizing Forceps823
 Uterine Sound816
 Uterine Tenaculum Forceps817-820
- V**
 Vaginal Retractor801-805, 810
 Vaginal Speculum798-810
 Valleix, Uterine Sound816
 Valve Attachment882
 Valve hook583
 Valve Rubber Bulb880
 Van Buren, Urethral Sound790
 Van Doren, Uterine Biopsy Forceps828
 Vannas, Micro Scissors698
 Varady, Micro Dissector349
 Varady, Micro Phlebextractor349
 Varady, Mini Phlebextractor349
 Varady, Olive348
 Varady, Phlebextractor349
 Varady, Phlebodissector349
 Varady, Varicose Vein Probe Set348
 Varicose Vein Probe Set348, 350
 Vascular Clamp203, 627
 Vascular Dilator666-667
 Vascular Dissector670
 Vascular Forceps610-611, 656
 Vascular Measuring Caliper604
 Vascular Scissors80-84, 88-90, 107, 134
 Veidenheimer, Sigmoid Anastomosis
 Forceps772
 Vein Cannula376
 Vein Hook248
 Vein Tip668
 Verbrugge, Bone Holding Forceps534, 535
 Verhoeven, Suction Cannula377
 Verres, Insufflation Cannula378
 Vessel Clip172, 179
 Vessel Hook242
 Vessel Irrigation Cannula378, 379
 Vickers Low-Profile, Central Blade322
 Vickers Low-Profile, Wound Spreaders,
 self-retaining322
 Vickers, Wound Spreaders, self-retaining322
 Vidal, Lupus Scraper744
 Virchow, Brain Knife3
 Virchow, Skull Breaker464
 Volkmann, Bone Curette490, 491
 Volkmann, Bone Curette, double-ended496
 Volkmann, Retractor250-252
 Vollmar, Ring Stripper351
 Vollmar, Vessel Irrigation Cannula378

W

Wachenfeldt, Clip Applying Forceps444
 Wagnener, Ear Hooklet.....878
 Wagner, Laminectomy Rongeurs730
 Wagner, Operating Scissors100
 Waldmann, Episiotomy Scissors.....97
 Walter, Gouge913
 Walter, Osteotome913
 Wangenstein, Dressing Forceps146
 Wangenstein, Needle Holder.....416, 428
 Washer880
 Wassmund, Retractor.....256
 Waste Bucket.....974
 Waste Forceps.....974
 Water Jet Pistol968
 Watson-Cheyne, Dissector, double-ended.....513
 Watson-Williams, Ethmoid Bone Forceps893
 Waugh, Dissecting Forceps.....152
 Waugh, Dressing Forceps140
 Weber, Aortic Clamp624
 Weber-Loch, Foreign Body Instrument877
 Webster, Needle Holder412, 419, 423-424
 Weight for Vaginal Speculum.....808-809
 Weights869
 Weil, Nasal Cutting Forceps.....893
 Weil-Blakesley, Ethmoid Bone Forceps ..894-895
 Weil-Blakesley, Nasal Cutting Forceps894
 Weissbarth, Strainer for Vaginal Speculum.....810
 Weissbarth, Vaginal Speculum810
 Weitlaner, Wound Spreaders,
 self-retaining30, 303, 306-307, 446-447
 Weitlaner-Baby, Wound Spreaders,
 self-retaining311
 Weitlaner-Wullstein, Wound Spreaders,
 self-retaining308
 Wertheim, Gynecological Scissors46
 Wertheim, Hysterectomy Forceps223
 Wertheim-Cullen, Vaginal Clamp220
 Westcott, Strabismus Scissors110
 Westmacott, Nasal Tampon Forceps890
 White, Tonsil Grasping Forceps935
 Wikstroem, Dissecting and Ligature Forceps ..211
 Williams, Intestinal and
 Tissue Grasping Forceps.....752
 Williams, Wound Spreaders, self-retaining310
 Williger, Bone Curette, double-ended497
 Williger, Elevator513
 Williger, Mallet.....484, 486
 Williger, Periosteal Elevator505
 Wing nut775
 Winter, Placenta and Ovum Forceps840
 Wire Bending Forceps.....856
 Wire Cutting Scissors.....121-122, 135
 Wire Loop936
 Wire Saw682
 Wire Saw Guide.....682
 Wire Saw Handle.....682
 Wolff, Lupus Curette.....744
 Wolff, Plaster Breaker457
 Wound and Bladder Syringes384
 Wound Spreaders, self-retaining30, 298-323,
446-447
 Wrench.....668
 Wrigley, Obstetrical Forceps838
 Wullstein, Micro Ear Scissors.....855
 Wullstein, Sickle Knife.....859
 Wullstein, Suction Cannula363
 Wullstein, Suction Tube363
 Wylie, Aortic Clamp601, 625

Y

Yankauer, Handle367
 Yankauer, Olive367
 Yankauer, Suction Tip367
 Yankauer, Suction Tube.....366, 367
 Yankauer, Suction Tube.....367
 Yasargil, Galea hook686
 Yasargil, grasping forceps.....702
 Yasargil, Micro Curette.....708

Yasargil, Micro Dissecting Scissors.....699
 Yasargil, Micro Dissector707
 Yasargil, Micro Forceps702
 Yasargil, Micro Needle Holder.....701
 Yasargil, Micro Periosteal Elevator.....706
 Yasargil, Micro Scissors.....699
 Yasargil, Micro vascular knife705
 Yasargil, Pituitary Rongeur731, 732
 Yasargil, Suction Tube.....365
 Yasargil, Suture guide706
 Yasargil, tumor forceps702
 Yasargil, Tumor fork.....704
 Yasargil-Samii, grasping forceps.....702
 Young, Needle Holder436
 Young, Prostatic Retractor785
 Young, Spare Needle436

Z

Zanger, Aortic Clamp606
 Zaufal, Foreign Body Lever877
 Zaufal-Jansen, Bone Rongeur539
 Zeller, Protection Spectacle.....952
 Zenker, Dissecting and Ligature Forceps.....209
 Zenker, Retractor.....265
 Zielke, Gouge.....467
 Zöllner, Ear Specula, Set.....865
 Zöllner, Ear Speculum865
 Zöllner, Suction Cannula.....362
 Zöllner, Suction Tip362
 Zweifel, Needle Holder434

Índice, alfabético
Español



A			
Acumulador inductivo.....	399, 400		
Adaptador.....	792		
Adaptador de irrigación.....	883		
Adaptador Luer.....	668		
Adaptador para catéteres.....	380		
Adlerkreutz, Pinza de disección con diente.....	151		
Adson, Elevador.....	510		
Adson, Gancho para duramadre.....	696		
Adson, Pinza de disección.....	140, 144		
Adson, Pinza de disección con diente.....	144, 152		
Adson, Pinza para preparación y ligadura.....	192		
Adson, Porta-agujas.....	413		
Adson, Separador autoestático.....	304-306, 313-314, 318		
Adson, Tubo de aspiración.....	360		
Adson-Baby, Pinza para preparación y ligadura.....	201		
Adson-Brown, Pinza de disección con diente.....	144, 155		
Agrafe de sutura.....	445		
Aguja de disección.....	402-403		
Aguja de repuesto.....	174, 436		
Aguja para amígdalas.....	364, 377		
Aguja para heparín.....	376, 379		
Aguja para ligadura.....	436-440		
Aguja para paracentesis.....	878		
Aguja para punción del hígado.....	379		
Aguja para punción lumbar.....	377		
Alambre.....	870, 888, 936		
Alan-Parks, Separador rectal.....	775		
Alderdyce, Disector doble.....	513		
Alexander, Cíncel.....	467		
Alexander, Gubia.....	467		
Alexander, Perióstomo.....	508		
Alexander, Pinza para biopsia.....	829		
Allen, Pinza intestinal.....	758		
Allenberg-Cobra, Pinza vascular de usos múltiples.....	664		
Allis, Pinza para intestinos y tejidos.....	750-751		
Allis-Adair, Pinza para intestinos y tejidos.....	751		
Allis-Baby, Pinza para intestinos y tejidos.....	750		
Allison, Espátula pulmonar.....	586		
Alm, Separador autoestático.....	300		
Amniótomo.....	817		
Anderson-Adson, Separador autoestático.....	301		
Anillo de goma.....	776		
Anoscopio.....	774		
Apoyapiés.....	868		
Aproximador.....	172-174		
Aproximador para costillas.....	584		
Aproximador para nervios.....	174		
Aquila, Tijera para histerectomía.....	132-133		
Arruga, Micro Porta-Agujas.....	408		
Arruga, Porta-agujas.....	411, 422		
Articulacion esférica.....	692, 693		
Asa de alambre.....	936		
Asch, Pinza para enderezar el tabique nasal.....	924		
Aston, Tijera para Face-lift.....	57		
Aufricht, Escofina para glabella.....	918		
Aufricht, Separador nasal.....	921, 923		
Austin, Disecador para el ático.....	862		
Austin, Micro Pinza para anudar.....	167		
Auvard, Espéculo vaginal.....	809		
Ayre, Bisturí para cono.....	824		
B			
Babcock, Pinza para intestinos y tejidos.....	752-753		
Baby-Adson, Pinza hemostática.....	185		
Baby-Poole, Tubo de aspiración.....	368		
Backhaus, Pinza de campo.....	226		
Bailey, Aproximador para costillas.....	584		
Bailey-Baby, Aproximador para costillas.....	584		
Bailey-Gibbon, Aproximador para costillas.....	584		
Bainbridge, Pinza vascular de usos múltiples.....	618		
Bakes, Dilatador para conducto biliar.....	781		
Balfour, Mod. USA, Separador abdominal.....	335		
Balfour, Mod. USA, Valva de alambre.....	335		
Balfour, Separador abdominal.....	332-333		
Balfour, Valva central.....	332, 334-335		
Balfour-Baby, Separador abdominal.....	331		
Balfour-Standard, Separador abdominal.....	334		
Ballenger, Cuchillo para tabique nasal.....	906		
Ballenger, Gubia para tabique nasal.....	911		
Ballenger-Hajek, Elevador para tabique nasal.....	909		
Bandeja para agujas.....	959		
Bandeja universal.....	963		
Barbara, Micro Aguja auricular.....	860-861		
Barbara, Micro Ganchito auricular.....	860		
Baron-Schuknecht, Tubo de aspiración.....	363		
Barra transversal.....	343		
Barraquer, Micro Porta-Agujas.....	409, 423		
Barraquer, Pinza depilatoria.....	169		
Barraquer-Troutman, Micro Porta-Agujas.....	408		
Base de Bakelit.....	869		
Bastidor, suelto.....	327, 337-339, 565-568, 570, 572-574, 579-581		
Beacham, Amniótomo.....	817		
Beck, Pinza vascular de usos múltiples.....	642, 651		
Beckman-Adson, Separador autoestático.....	319		
Beckman-Eaton, Separador autoestático.....	320		
Beckmann, Cuchillo para adenoides.....	926		
Beckmann, Separador autoestático.....	317		
Beebe, Tijera para cortar hilos de acero.....	122		
Beer, Pinza depilatoria.....	169		
Bellucci, Micro Tijera auricular.....	854		
Bengolea, Pinza hemostática.....	195		
Bennett, Elevador para hueso.....	518		
Benson, Separador para piloro.....	761		
Bergmann, Pinza para tapones.....	236		
Bergmann, Tijera para yeso.....	451		
Bernhard, Pinza de campo.....	227		
Bethune, Costótomo.....	555		
Beyer, Pinza cortante para hueso.....	875		
Beyer, Pinza gubia.....	539		
Biemer, Clip vascular.....	172		
Biemer, Tijeras de micro para venas.....	116		
Biemer-Müller, Aproximador.....	173		
Billeau, Asa auricular.....	877		
Bircher-Ganske, Pinza para cartílago.....	525		
Bisturí desechable.....	13-14		
Bisturí para cono.....	824		
Bisturí para disección.....	2		
Bisturi tumor.....	704		
Blake, Cucharilla uterina.....	831		
Blake, Pinza para cálculos biliares.....	782		
Blohmke, Pinza para amígdalas.....	935		
Blount, Separador para rodilla.....	519		
Blumenthal, Pinza gubia.....	538		
Böhler, Pinza cortante para hueso.....	546		
Böhler, Pinza gubia.....	539		
Bombilla de recambio.....	391, 398		
Bonney, Pinza de disección con diente.....	143, 158		
Borowski, Separador para aorta.....	282		
Botón de repuesto.....	868		
Bowman, Sonda.....	845		
Boys-Allis, Pinza para intestinos y tejidos.....	751		
Bozemann, Pinza para tapones.....	235		
Bozemann, Porta-agujas.....	429		
Bozemann, Tuerce-lazos.....	443		
Braun, Depresor uterino.....	816		
Braun, Pinza para cuello uterino.....	817, 820		
Braun-Stadler, Tijera para episiotomía.....	97		
Brazo de fijación.....	343, 692-693		
Brazo flexible.....	690, 691, 692		
Breisky, Espéculo vaginal.....	810		
Brom, Ganchito para venas.....	248		
Brompton, Pinza de rodillos.....	230		
Brophy, Pinza de disección con diente.....	153		
Brown, Porta-agujas.....	413		
Brünings, Cierra-nudo para amígdalas.....	936		
Brünings, Cuchillo para amígdalas.....	933		
Brünings, Pinza intercambiable.....	938		
Brünings, Pinza para tabique nasal.....	891		
Brünings, Tubo de extensión.....	830		
Brünings, Tubo de laringeo.....	937, 938, 939		
Brunner, Aguja para ligadura.....	440		
Brunner, Costótomo.....	556		
Brunner, Pinza para anastomosis rectales.....	770		
Brunner, Separador.....	278-279		
Brunner, Sonda conductora.....	440, 442		
Bruns, Cucharilla cortante.....	492-493		
Bruns, Tijera para yeso.....	452, 454		
Buck, Cureta auricular.....	876		
Buck, Elevador para cuerpos extraños.....	872		
Buck, Tijera para hilos.....	120		
Buckley, Separador autoestático.....	299		
Bujía uretral.....	790		
Burford, Separador costal.....	560		
Busch, Tijera umbilical.....	98		
Bushe, Cucharilla cortante.....	495		
Byrd, Tubo de aspiración.....	373		
C			
Caballote para cápsulas de Petri.....	956		
Cabeza de acoplamiento.....	691-693		
Cabeza para venas.....	668		
Cabezal para aspiración.....	367		
Cable de tracción.....	350		
Caja interior.....	958		
Caja metálica redonda.....	965		
Caja para instrumentos.....	812, 964		
Calibre.....	794		
Calne, Pinza para Vena Cava.....	625		
Cánula.....	376		
Cánula auricular.....	880		
Cánula para anestesia transvaginal.....	376		
Cánula para insuflación.....	378		
Cánula para irrigación vascular.....	378, 379		
Cánula para venas.....	376		
Caperuza protectora.....	900		
Caplan, Pinza para tabique nasal.....	899		
Cargador inductivo.....	400		
Carpenter, Cuchillo/enucleador para amígdalas.....	933		
Caspar, Ganchito para nervios y vasos.....	709		
Caspar, Micro Disecador.....	705		
Caspar, Micro Tijera.....	700		
Caspar, Pinzas para laminectomía.....	724-729		
Caspar, Punzón metálico.....	483		
Caspar, Tenedor sutura.....	705		
Castañeda, Pinza vascular para recién nacidos.....	677		
Castañeda, Separador costal.....	561		
Castroviejo, Compas.....	844		
Castroviejo, Micro Porta-Agujas.....	404-405, 410-411, 422-423		
Castroviejo, Micro Tijera.....	111		
Castroviejo, Porta-hoja / Rompe-hoja de afeitar.....	4		
Castroviejo-Epker, Compas.....	844		
Castroviejo-Fino, Micro Porta-Agujas.....	409		
Cepillo de limpieza.....	974-977		
Cepillo para uñas.....	948		
Cerullo, Tubo de aspiración.....	365		
Chaput, Pinza hemostática.....	183		
Cheattle, Pinza para esterilización.....	956		
Cheron, Pinza para vendajes.....	235		
Childe, Pinza aproximadora.....	444		
Cierra-nudo para amígdalas.....	936		
Cierre para clamps intestinales.....	762		
Cilindro de repuesto.....	381-384		
Cíncel.....	464-468, 469, 472-473, 478-480, 481, 913		
Cíncel de esponjosa.....	471		
Cíncel nasal.....	914		
Cíncel para esternón.....	556		
Cíncel para tabique nasal.....	911		
Cíncel rompe-cráneo.....	464		
Cinelli, Osteótomo.....	914		
Cinelli, Tijera nasal.....	63		
Cinta frontal.....	952		
Citelli, Pinza cortante para hueso.....	874		
Cizalla para hueso.....	554		
Clamp Bulldog.....	176-181, 589, 590-593, 611-612		

- Clamp para pene795
 Clamp umbilical842
 Cleveland, Pinza cortante para hueso546
 Cleveland, Pinza gubia536
 Clip vascular172, 179
 Cloward, Separador autoestático315-316
 Cloward, Separador para
 cuerpos vertebrales710
 Cloward, Valva315-316
 Coakley, Cureta para el antro925
 Cobb, Gubia479
 Cobbs, Perióstotomo503
 Cobo para desechos974
 Cogswell, Tubo de aspiración373
 Collier, Porta-agujas412
 Collin, Clamp umbilical842
 Collin, Espéculo vaginal798
 Collin, Histerolabo823
 Collin, Mango de bisturí6
 Collin, Martillo485
 Collin, Pinza para sacar órganos184
 Collin, Pinza para vendajes235
 Collin, Separador abdominal324-326,
 328-329
 Collin-Baby,
 Separador abdominal324, 327, 328, 329
 Collin-Hartmann, Separador294
 Compas844
 Compas para medir vasos604
 Conductor para sierras de hilo682
 Cone, Pinza sacabocado craneal684
 Conector380
 Cono793
 Cono de carga776
 Cono de conexión881
 Contenedor de pila398
 Converse, Cuchillo para rinoplástica905
 Converse, Ganchito para alas de nariz922
 Converse, Separador nasal922
 Converse, Tijera nasal96
 Cooley, Dilatador aórtico665
 Cooley, Dilatador vascular666
 Cooley, Pinza aórtica608-609, 621
 Cooley, Pinza de disección vascular656
 Cooley, Pinza para anastomosis657-658, 660
 Cooley, Pinza para carótida659
 Cooley, Pinza para catéteres605
 Cooley, Pinza para iliaca658
 Cooley, Pinza vascular
 de usos múltiples647-648, 659-663
 Cooley, Pinza vascular pediátrica657
 Cooley, Separador atrial582
 Cooley, Separador costal558-559
 Cooley, Separador para atrio289
 Cooley, Tubo de aspiración370-371
 Cooley, Valva lateral573, 578
 Cooley-Beck, Pinza para anastomosis664
 Cooley-Derra, Pinza para anastomosis662, 664
 Cooper, Aguja para ligadura437
 Cordes, Pinza intercambiable939
 Coryllos, Separador275
 Costótopo554-556
 Cottle, Cuchillo para rinoplástica905
 Cottle, Elevador para tabique nasal909-910
 Cottle, Escofina nasal917
 Cottle, Espéculo nasal886-887
 Cottle, Ganchito nasal921
 Cottle, Ganchito para alas de nariz923
 Cottle, Legra para tabique nasal910
 Cottle, Machacadora916
 Cottle, Mango en forma T916
 Cottle, Martillo485
 Cottle, Osteótomo912
 Cottle, Perióstotomo501
 Cottle, Pinza para columela925
 Cottle, Pinza para piel925
 Cottle, Separador en forma de silla923
 Cottle, Separador nasal923
 Cottle, Soporte de guía916
 Cottle, Tijera nasal95-96
 Cottle-Kazanjian, Pinza cortante
 para hueso545
 Cottle-Neivert, Ganchito para alas de nariz923
 Cottle-Walsham, Pinza para enderezar
 el tabique nasal924
 Coupland, Mango para tubos de aspiración373
 Coupland, Punta de succión373
 Crafoord, Pinza para preparación y ligadura203
 Crafoord, Pinza para vasos203
 Crafoord-Sellers, Pinza para vasos203
 Crile, Ganchito para nervios671
 Crile, Pinza hemostática190
 Crile, Porta-agujas417
 Crile-Murray, Porta-agujas413
 Crile-Rankin, Pinza hemostática191
 Crile-Wood, Porta-agujas413, 419,
 424, 446-447
 Crutchfield, Estribo de tracción craneal683
 Cubeta de acero inoxidable962
 Cubeta redonda962
 Cucharilla auricular877, 879
 Cucharilla cálculos biliares784
 Cucharilla cortante490-496
 Cucharilla de doble extremo496-497
 Cucharilla para aborto841, 842
 Cucharilla uterina831-832, 834
 Cucharilla/ganchito auricular877
 Cuchillo de hoz859
 Cuchillo de paleta844
 Cuchillo para adenoides926
 Cuchillo para amígdalas933
 Cuchillo para amputación15
 Cuchillo para cerebro3
 Cuchillo para cortes redondos859
 Cuchillo para fibroma822
 Cuchillo para lóbulos859
 Cuchillo para menisco520
 Cuchillo para mucosa859, 906
 Cuchillo para resección15
 Cuchillo para tabique nasal906
 Cuchillo para yeso455
 Cuchillo rinoplástico905
 Cuchillo/enucleador para amígdalas933
 Cureta aspiradora825, 834
 Cureta auricular876
 Cureta cortante497
 Cureta de doble extremo497, 925
 Cureta para biopsia825
 Cureta para el antro925
 Cureta para lupus744
 Cureta para lupus744
 Cusco, Espéculo vaginal798
 Cushing, Gancho en forma de silla246
 Cushing, Gancho para nervios695
 Cushing, Pinza de disección142, 145
 Cushing, Pinza de disección con diente154
 Cushing, Separador245
 Cushing-Landolt, Espéculo hipófisis733
 Cushing-Taylor, Pinza de disección145
 Cuzzi, Cucharilla para aborto841
 Czerny, Espéculo rectal774
 Czerny, Pinza para cuello uterino820
D
 Dahlgren, Pinza sacabocado craneal684
 Dale, Pinza para vasos periféricos597
 Dandy, Pinza hemostática191
 Dandy-Mosquito, Pinza hemostática191
 Dardik, Pinza vascular de usos múltiples596
 Dartigues, Histerolabo823
 d'Assumpção, Pinza para Face-lift747
 Daubenspeck, Cucharilla cortante491
 Davidson, Separador para escápula276
 Davis, Disecador para duramadre688
 Day, Ganchito auricular878
 De Bakey, Clamp Bulldog591
 De Bakey, Dilatador vascular667
 De Bakey, Pinza aórtica621, 655
 De Bakey, Pinza aplicadora612
 De Bakey, Pinza de disección
 atraumática147-148
 De Bakey, Pinza de disección vascular610-611
 De Bakey, Pinza para anastomosis632
 De Bakey, Pinza para aneurisma
 de aórtica619-620
 De Bakey, Pinza para ligaduras615, 622-623
 De Bakey, Pinza para vasos periféricos616
 De Bakey, Pinza vascular de usos
 múltiples618, 636-637, 639-641, 650
 De Bakey, Pinza vascular pediátrica643
 De Bakey, Porta-agujas426
 De Bakey, Separador costal565-568
 De Bakey, Separador suelto565-568
 De Bakey, Tijera acodada134
 De Bakey, Tijera de disección62
 De Bakey, Tijera vascular82
 De Bakey, Tubo de aspiración366
 De Bakey, Valva lateral565-569
 De Bakey-Adson, Tubo de aspiración366
 De Bakey-Bahnson, Pinza para aneurisma634
 De Bakey-Beck, Pinza para anastomosis642
 De Bakey-Derra, Pinza vascular
 de usos múltiples652
 De Bakey-Diethrich, Clamp Bulldog178
 De Bakey-Mosquito,
 Pinza hemostática594, 638
 De Bakey-Pean, Pinza hemostática638
 De Bakey-Rankin, Pinza hemostática594
 De Bakey-Reynolds, Pinza vascular
 de usos múltiples641
 De Bakey-Satinsky, Clamp Bulldog592
 De Bakey-Satinsky, Pinza vascular
 de usos múltiples653
 De Martel, Conductor para sierras de hilo682
 De Martel-Wolfson, Pinza para
 anastomosis intestinales760
 De Martel-Wolfson, Pinza para
 cerrar grapas760
 De Martel-Wolfson, Porta-clamp761
 De Vilbiss, Pinza sacabocado craneal684
 Dean, Tijera para amígdalas93-94
 Deaver, Separador286-288
 Deaver, Tijera quirúrgica33
 DeBakey, Pinza aórtica602
 Depresor uterino816
 Derf, Porta-agujas412, 423
 Dermatomo17
 Derra, Pinza para anastomosis642
 Deschamps, Aguja para ligadura438-439
 Desjardins, Pinza para cálculos biliares783
 Desjardins, Pinza para conducto biliar216
 Desmarres, Gancho en forma de silla243
 Diapasón866-869
 Dieffenbach, Clamp Bulldog176
 Diethrich, Clamp Bulldog178
 Diethrich, Pinza aórtica595
 Diethrich, Tijera vascular81, 84, 89
 Diethrich-Salyer, Tijera de disección82
 Dilatador aórtico665
 Dilatador para conducto biliar781
 Dilatador para el cuello vesical788
 Dilatador para el seno maxilar926
 Dilatador traqueal740
 Dilatador uterino811-815
 Dilatador uterino, juego812
 Dilatador vascular666-667
 Dingmann, Pinza para cartílago525
 Disco protector882
 Disecador para duramadre688-689
 Disecador para duramadre686-688
 Disecador para duramadre687-688
 Disecador para el ático862
 Disecador para el paladar932
 Disector doble513
 Disector vascular670
 Dispensador de cepillos948
 Dispositivo fijador690, 691
 Douglas, Pinza depilatoria169
 Doyen, Espéculo vaginal806

Doyen, Legra costal	507
Doyen, Martillo.....	484
Doyen, Pinza intestinal	754, 766
Doyen, Separador	273
Doyen, Sonda acanalada	347
Doyen, Tijera para ginecología	44
Doyen, Tira-miomas	822
Doyen, Valva vaginal	810
Doyen-Baby, Pinza intestinal	755, 766
Doyen-Stille, Separador	269
Dubost, Separador suelto	570
Dubost, Separador torácico	570
Dubost, Valva lateral	570, 571
Dunhill, Pinza hemostática.....	189
Duplay, Pinza para cuello uterino	817
Durante, Pinza de disección con diente.....	157
Duval, Pinza para intestinos y tejidos	753-754
E	
Echlin, Pinza gubia	541
Eicken-Killian, Sonda irrigadora para seno maxilar	926
Eiselsberg, Tijera para hilos	120
Elevador	510, 512-513
Elevador obstétrico	840
Elevador para amígdalas	933-934
Elevador para cuerpos extraños.....	872, 877
Elevador para el paladar	932
Elevador para hueso	514-519
Elevador para tabique nasal	907-910
Emmett, Gancho para fístulas.....	824
Enucleador de tendones.....	521-522
Escofina nasal	917-920
Escofina para el antro	917
Escofina para glabella.....	918
Escofina para hueso	482
Esfinteroscopia.....	776
Esmarch, Cuchillo para yeso.....	455
Esmarch, Tijera para yeso.....	451
Espátula.....	694
Espátula abdominal.....	293, 344
Espátula cerebral	690
Espátula para fasciotomía	669
Espátula para la íntima	670
Espátula pulmonar	586
Espéculo auricular.....	864-865
Espéculo auricular, juego	864-865
Espéculo endocervical	811
Espéculo hipófisis	733
Espéculo nasal.....	884-887
Espéculo rectal	774
Espéculo vaginal	798-810
Espejo laringeo	940-941
Espina de repuesto	683
Estríbo de tracción craneal.....	683
Estuche para agujas	957, 961-963
Estuche para laringoscopios	391
Eves, Cierra-nudo para amígdalas	936
Extractor para comedones	746
F	
Fahlbusch, Micro Tijera.....	700
Farabeuf, Periostótomo	502
Farabeuf, Pinza para huesos.....	530
Farabeuf, Separador	295
Farabeuf-Collin, Periostótomo.....	502
Farell, Porta-algodón	352
Farrior, Espéculo auricular.....	865
Faulkner, Cureta de doble extremo	925
Faure, Pinza para biopsia	826
Faure, Pinza para peritoneo	225
Favaloro, Tijera vascular	88, 90
Fehland, Pinza para anastomosis rectales	772
Feilchenfeld, Pinza para espinas.....	167
Fergusson, Pinza para huesos	527
Fergusson, Tubo de aspiración	361
Ferris-Smith-Kerrison, Pinza sacabocado para esfenoide	902
Filiforme, Sonda filiforme	791
Finocchio, (modif.), Separador costal	561
Finocchio, Baby, Separador costal	564
Finocchio, Infant, Separador costal	559
Finocchio, Pinza para preparación y ligadura	213
Finocchio, Porta-agujas	415, 427
Finocchio, Separador costal	560, 564
Finsen, Separador autoestático	298
Finsen-Martin, Separador autoestático.....	298
Fisch, Micro Disecador	862
Fisher, Cuchillo para amígdalas	933
Flebextractor	349
Fleboextractor.....	349
Fleboextractor	351
Fleboextractor.....	913
Fomon, Cuchillo rinoplástico	905
Fomon, Escofina nasal	918, 920
Fomon, Gancho para alas de nariz	921-922
Fomon, Tijera nasal	63, 95
Forceps obstétricos	838-839
Foregger, Hoja de laringoscopia	390, 391
Foregger, Hoja de laringoscopia (luz fría)	395
Foregger, Juego de laringoscopios	390
Foregger, Juego de laringoscopios (luz fría)	394
Förster, Pinza para taponos	236-237
Foster-Gillies, Porta-agujas	432
Fox, Cureta para lupus	744
Fraenkel, Pinza intercambiable	938
Frasco suelto	880
Frazier, Gancho para duramadre	697
Frazier, Tubo de aspiración	360-361
Freeman, Tijera para Face-lift.....	748
Freeman-Kaye, Tijera para Face-lift	748
Freer, Cíncel para tabique nasal.....	911
Freer, Cuchillo para mucosa	906
Freer, Cuchillo para tabique nasal	906
Freer, Elevador para tabique nasal	907-908
Freer, Gancho para mucosa	922
Freer, Gubia para tabique nasal	911
French, Diapasón	866
Friedmann, Pinza gubia	536
Fritsch, Separador	272
Frosch, Pinza para huesos.....	527
Frykholm, Pinza gubia	542
Fuller, Pinza para introducir	858
G	
Gafa protectora	952
Gallaher, Escofina para el antro	917
Ganchito	241-245, 248-249, 446-447
Ganchito auricular.....	877-878
Ganchito de piel.....	240-241, 745
Ganchito explorador.....	862
Ganchito nasal	921
Ganchito para alas de nariz	921-923
Ganchito para el paladar	932
Ganchito para mucosa	921-922
Ganchito para nervios	671
Ganchito para nervios y vasos	709
Ganchito para venas	248
Ganchito vascular.....	242
Gancho	341
Gancho en forma de silla	243, 246-247, 923
Gancho Galea	686
Gancho para duramadre.....	696-697
Gancho para Face-lift	745
Gancho para fístulas	824
Gancho para huesos	240
Gancho para nervios	695
Gancho traqueal	741
Gancho valvá	583
Gardner, Cíncel	464
Garrucha	343
Gellhorn, Pinza para biopsia	826
Gelpi, Separador autoestático	323
Gemini, Pinza para preparación y ligadura	207
Gerald, Pinza de disección	142
Gerald, Pinza de disección atraumática	148
Gerald, Pinza de disección con diente	143, 154
Gierzt-Stille, Costótomo	555
Gigli, Mango de gancho	682
Gigli, Sierra de hilo	682
Gillies, Ganchito para piel	745
Gillies, Pinza de disección con diente	143, 152
Gillies, Porta-agujas.....	417, 432
Gillies-Mini, Porta-agujas	432
Gil-Vernet, Gancho en forma de silla	247
Glover, Clamp Bulldog.....	592, 612
Glover, Pinza para anastomosis	631
Glover, Pinza vascular de usos múltiples.....	640
Gluck, Costótomo	554
Goelet, Separador.....	297
Goldman-Fox, Tijeras para encías	99
Goldmann-Fox, Tijera para ligaduras.....	99
Goldsmith (Thudichum), Espéculo nasal.....	884
Good, Tijera para amígdalas.....	93
Goodell, Dilatador uterino	811
Gorney, Tijera para Face-Lift.....	57, 131, 748
Gosset, Separador abdominal	330-331
Gosset-Baby, Separador abdominal	330
Graefe, Micro Ganchito	240
Graefe, Tijera para iridectomía	104
Graham, Gancho para duramadre.....	696
Graig, Pinza para tabique nasal	891
Grant, Pinza aórtica	607
Grapa para cuero cabelludo	685
Grapa para cuero cabelludo	685
Grave, Espéculo vaginal	799
Green-Armytage, Pinza uterina para hemostasis	840
Greene, Cureta uterina	834
Gregory, Clamp Bulldog.....	593
Gregory, Micro Porta-Agujas.....	420
Gregory, Pinza para la profunda	598
Gregory, soft, Clamp Bulldog	593
Gregory, Tijera para Face-lift	747
Groningen, Gancho para nervios.....	695
Gross, Cucharilla/ganchito auricular	877
Gross-Maier, Pinza para vendajes	234, 446-447
Grünwald (Jansen), Pinza para taponamiento	890
Grünwald, Pera de goma	880
Grünwald, Pinza auricular	871
Grünwald, Pinza para taponamiento	890
Gubia para tabique nasal	911
Guedel-Negus, Hoja de laringoscopia	388
Guedel-Negus, Juego de laringoscopios	388
Guilen, Legra de succión	926
Gunnar-Hey, Pinza de rodillos.....	230
Guthrie, Ganchito de piel	241
Guttman, Espéculo vaginal	799
Guyon, Bujía uretral	790
Guyon, Pinza para pedículo renal	214-215
H	
Haberer, Espátula abdominal.....	344
Hach, Espátula para fasciotomía.....	669
Haight, Separador costal	562
Hajek, Pinza sacabocado para esfenoide	901
Hajek-Kofler, Pinza sacabocado para esfenoide	901
Halle, Cucharilla cortante.....	495
Halle, Elevador para tabique nasal	907
Halsey, Porta-agujas	412, 424
Halsted-Mosquito, Pinza hemostática.....	186-187, 446-447
Hank, Dilatador uterino.....	815
Harken, Pinza para aurícula	629
Harrington, Separador	285
Hartmann, Diapasón.....	866-868
Hartmann, Espéculo auricular	864
Hartmann, Espéculo auricular, juego.....	864
Hartmann, Ganchito auricular.....	877
Hartmann, Pinza gubia	537
Hartmann, Pinza hemostática	186
Hartmann, Pinza nasal cortante	898
Hartmann, Pinza para amígdalas.....	937
Hartmann, Pinza para pólipos auriculares	872-873
Hartmann, Pinza para pólipos nasales	890

- Hartmann, Separador autoestático311
Hartmann, Sonda auricular870
Hartmann-Halle, Espéculo nasal884
Hartmann-Herzfeld, Pinza para
pólipos auriculares873
Hartmann-Hoffman, Pinza para
pólipos auriculares873
Hartmann-Wullstein, Pinza para
pólipos auriculares873
Hayes, Pinza para anastomosis rectales771
Heaney, Pinza para histerectomía219
Heaney, Porta-agujas414, 426
Hegar, Dilatador uterino812-814
Hegar, Dilatador uterino, juego812
Hegar, Porta-agujas429
Hegar-Baumgartner, Porta-agujas413, 424
Hegar-Vascular, Porta-agujas429
Hegenbarth, Pinza aplicadora para agrafes.....444
Heifetz, Espátula.....694
Heifetz, Pinza de sujeción702
Heiming, Pinza para cálculos renales780
Heiss, Pinza para preparación y ligadura.....201
Henckel-Tilley, Pinza nasale870
Henke, Elevador para amígdalas934
Henley, Separador autoestático312
Henley, Valva central312
Henly, Pinza para catéteres604
Hennig, Separador para yeso456
Hepp-Scheidel, Micro Porta-Agujas419
Hepp-Scheidel, Pinza para tubos159
Heymann, Tijera nasal96
Heywood-Smith, Pinza para
pólipos uterinos.....821
Hibbs, Cíncel480
Hibbs, Gubia481
Hibbs, Osteótomo480-481
Histerolabo823
Histerómetro816
Hohenfellner, Tijera de disección61
Hohman, mini, Elevador para hueso514
Hohmann, Elevador para hueso515-517
Hoja de afeitar4
Hoja de cíncel470
Hoja de gubia470
Hoja de laringoscopia387-391
Hoja de laringoscopia
(luz fría)392-393, 395-397
Hoja de osteótomo470
Hoja de recambio453, 792
Hoja de repuesto17
Hoja de sierra10, 458
Hojas de bisturí, no estériles10-11
Hoke, Osteótomo480
Hopkins, Cuchillo para yeso455
Hopquilla de hilos443, 705
Hösel, Separador270
House, Micro Cucharilla863
House, Micro Sonda para medir863
House, Tubo de aspiración369
House-Dieter, Pinza para cabezal
del maléolo857
Howarth, Elevador para tabique nasal909
Huber, Mango universal830
Humby, Dermatómomo17
Humby, Hoja de repuesto17
Hunt, Pinza de sujeción703
Hunter, Pinza para espinas168
Hurd, Disector/separador para amígdalas933
Husfeldt, Pinza para vasos periféricos603
- I**
Imperdible para instrumentos960
Inge, Separador de hueso710
Inge, Separador para cuerpos
vertebrales710-711
Instrumento para circuncisión793
Instrumento para cuerpos extraños877
Instrumento para uretrografía793
Insuflador de aire881
Iowa, Pinza para cuello uterino819
- Israel, Separador257
Iterson, Gancho traqueal741
Ives-Fansler, Anoscopio774
- J**
JABOMA, Micro Porta-Agujas419
JABOMA, Micro Tijera117
JABOMA, Pinza de disección147
JABOMA, Pinza de disección con diente147
Jackson, Espéculo vaginal800
Jackson, Gancho traqueal741
Jacobs, Pinza para cuello uterino819
Jacobson, Cucharilla cortante496
Jacobson, Micro bisturí vascular705
Jacobson, Micro Porta-Agujas701
Jacobson, Micro Tijera114, 698
Jacobson, Sonda abotonada708
Jameson, Tijera de disección77
Jamieson, Tubo de aspiración372
Jamison, Porta-agujas415
Janet, Cilindro de repuesto384
Janet, Jeringa para vejiga y heridas384
Jansen, Cucharilla auricular877
Jansen, Perióstotomo500
Jansen, Pinza auricular871
Jansen, Pinza gubia537
Jansen, Separador autoestático300
Javid, Pinza para shunt carótido599
Jeringa381, 882
Jeringa auricular882-883
Jeringa de tres anillos382
Jeringa para insulina382
Jeringa para tuberculina383
Jeringa para vejiga y heridas384
Jeweler mod., Micro Pinza162
Jeweler mod., Micro pinza de dilatación162
Johns-Hopkins, Clamp Bulldog177
Johnson, Porta-agujas416
Joll, Separador para tiroides y vagina323
Jones, Pinza de campo226
Jones-Martin, Pinza de campo226
Joseph, Cuchillo rinoplástico905
Joseph, Elevador para tabique nasal907
Joseph, Ganchito para mucosa921-922
Joseph, Legra para tabique nasal910
Joseph, Lima para huesos917
Joseph, Sierra nasal915
Joseph, Tijera de disección73-74
Joseph, Tijera quirúrgica73,74
Joseph-Masing, Legra para tabique nasal910
Jud-Allis, Pinza para intestinos y tejidos751
Judd-Masson, Separador vesical788
Juego de laringoscopios387-390
Juego de laringoscopios
(luz fría)392, 394, 396
Juego de manicura para enfermeras950
Juego para tunelar668
Juego para varices348, 350
Junta de goma882
Jurasz, Pinza para pólipos laringeos942
- K**
Kabierske, Cánula auricular880
Kabierske, Frasco suelto880
Kabierske, Pera de goma con valva880
Kabierske, Pulverizador880
Kader, Espátula abdominal293
Kahre-Williger, Perióstotomo505
Kallmorgen, Espéculo vaginal805
Kallmorgen, Valva vaginal805
Kalt, Porta-agujas408
Katsch, Extractor para comedones746
Kaye, Gancho para Face-lift745
Kaye, Mango de bisturí9
Kaye, Tijera para Face-Lift57, 119, 747
Kaye-Millard, Ganchito248
Kelly, Esfinteroscopia776
Kelly, Pinza hemostática189
Kelly, Pinza para pólipos uterinos821
Kelly, Pinza para preparación y ligadura217
- Kelly, Separador268, 291
Kelly, Tijera quirúrgica42-43
Kelly-Rankin, Pinza hemostática190
Kern, Pinza para huesos529
Kerrison, Pinza cortante
para laminectomía712-723
Kerrison, Pinza sacabocado para maxilar904
Kevorkian, Cureta para biopsia825
Kevorkian, Pinza para biopsia829
Key, Perióstotomo503
Keyes, Trépano para piel745
Kielland, Forceps obstétricos839
Kielland-Luikart, Forceps obstétricos839
Killian, Elevador para tabique nasal909
Killian, Espéculo nasal885
Killian, Gubia para tabique nasal911
Killian-Claus, Gubia para tabique nasal911
Kilner, Ganchito para alas de nariz922
Kilner, Ganchito para piel745
Kilner, Porta-agujas423
Kilner, Tijera de disección76
Kirschner, Cuadro337-339
Kirschner, Separador abdominal337-338
Kirschner, Sonda conductora441-442
Kirschner, Valva337-339
Klapp, Separador249
KLING-EX, Quita-hojas10
Knight, Pinza para tabique nasal891
Knowles, Tijera para vendajes450
Knutson, Instrumento para uretrografía793
Knutson-Koch, Cono793
Kocher (Ochsner), Pinza hemostática198-199
Kocher, Pinza hemostática194, 446-447
Kocher, Pinza intestinal757-758, 768-769
Kocher, Separador253, 262, 266, 273
Kocher, Sonda para bocio742
Kocher-Langenbeck, Separador263-264
Kocher-Nippon, Pinza hemostática194
Koenig, Perióstotomo500
Kogan, Espéculo endocervical811
König, Diapasón869
König, Sonda conductora442
Koos, Micro bisturí vascular705
Körte, Separador256
Krause, Pinza intercambiable939
Krause, Polipótomo870, 888
Krause-Voss, Polipótomo870, 888
Krayenbühl, Ganchito para nervios y vasos709
Krenkel, Legra para el paladar907
Kressner, Pinza para tabique nasal924
Kristeller, Espéculo vaginal801-804
Kristeller, Valva vaginal801-804
Kronecker, Aguja para ligadura437
- L**
La Grange, Tijeras para encías101
Laborde, Dilatador traqueal740
Lahey, Pinza para coger el bocio742
Lahey, Pinza para conducto biliar213
Lahey, Separador261
Lambert-Kay, Pinza para anastomosis632
Lambert-Kay, Pinza vascular
de usos múltiples654
Lambotte, Osteótomo475-476
Lambotte, Perióstotomo508
Lambotte-Mini, Osteótomo474
Landolt, Perióstotomo500
Landolt, Pinza para tumores732
Landolt, Tubo de aspiración365
Lane, Pinza de campo228
Lane, Pinza gastro-intestinales
gemelas763-764
Lane, Pinza para huesos533
Lange, Ganchito para alas de nariz921
Lange, Pinza intercambiable938
Lange-Hohmann, Elevador para hueso517
Langenbeck, Cuchillo para resección15
Langenbeck, Cureta auricular876
Langenbeck, Elevador512
Langenbeck, Perióstotomo500

Langenbeck, Pinza para huesos	527	Mandril	926	Mayo-Stille, Tijera quirúrgica	36-37
Langenbeck, Porta-agujas	434	Mango	351, 367	McDonald, Disector doble	513
Langenbeck, Separador	258-260	Mango	350	McGee, Micro Ganchito auricular	861
Langenbeck-Green, Separador	260	Mango de acumulador		McGee, Pinza para plegar alambre	856
Langenbeck-Mini, Ganchito	243	inductivo	392, 394, 396, 399	McGinvey, Pinza para hemorroides	777
Lavadora	880	Mango de acumulador inductivo	399	McIndoe, Pinza de disección	140, 143
Lawrence, Pinza para preparación		Mango de bisturí	5-9, 12, 446-447	McIndoe, Tijera para neurocirugía	92
y ligadura	218	Mango de bisturí con cabeza orientable	6	McIntosh, Hoja de laringoscopia	389
Lazar, Micro Pinza para anudar	167	Mango de gancho	682	McIntosh, Hoja de laringoscopia	
Lebsche, Cíncel para esternón	556	Mango de pilas	391, 392, 394, 396, 398	(luz fría)	392-393
Lees, Pinza bronquial	630	Mango en forma T	916	McIntosh, Juego de laringoscopios	389
Legra costal	507	Mango para espéculo vaginal	807, 808	McIntosh, Juego de laringoscopios	
Legra de succión	926	Mango para espejo laríngeo	941	(luz fría)	392
Legra para el paladar	907, 932	Mango para tubos de aspiración	373	McKenzie, Elevador para tabique nasal	907-908
Legra para tabique nasal	910	Mango universal	668, 830	McKenzie, Pinza clipadora	685
Leksell-Stille, Pinza gubia	542	Manómetro para salpingógrafo	835	McQuigg-Mixter, Pinza para preparación	
Leland-Jones, Pinza para vasos periféricos	617	Marquard, Pinza gubia	540	y ligadura	212
Lempert, Cucharilla auricular	879	Martel-Rees, Pinza para Face-lift	185	Mead, Martillo	486
Lempert, Micro Legra auricular	879	Martillo	484-489	Mead, Pinza gubia	537
Lempert, Pinza gubia	537	Martin Aquajet, Pistola-lavatoria		Meatótomo	794
Leriche, Pinza hemostática	188	de chorro de agua	968	Meeker, Pinza para preparación y ligadura	218
Lewin, Pinza para huesos	526	Martin, Adaptador Luer	668	Menghini, Aguja para punción del hígado	379
Lewis, Escofina nasal	918	Martin, Cabeza para venas	668	Metzenbaum, Porta-agujas	413
Lexer, Cíncel de esponjosa	471	Martin, Compas para medir vasos	604	Metzenbaum, Tijera de disección	47-48,
Lexer, Gubia	473	Martin, Cuchillo para yeso	455	50-54, 56, 67, 70, 446-447
Lexer, Osteótomo	473	Martin, Diapasón	867	Metzenbaum-Aguila, Tijera de disección	49, 55
Lexer, Tijera de disección	58, 60, 127	Martin, Dispensador de cepillos	948	Metzenbaum-Aguila-Fino,	
Lexer-Baby, Tijera de disección	64	Martin, Espátula abdominal	344	Tijera de disección	67, 70
Lexer-Fino, Tijera fina de disección	65	Martin, Espéculo nasal	885	Metzenbaum-Fino, Tijera fina	
Lexer-Mini, Gubia	472	Martin, Juego para tunelar	668	de disección	66-71, 128, 130
Lexer-Mini, Osteótomo	472	Martin, Llave horquilla	668	Metzenbaum-Lahey, Tijera de disección	128
Leyla, Articulación esférica	692, 693	Martin, Mango universal	668	Metzenbaum-Nelson, Tijera de disección	52-54
Leyla, Brazo de apoyo	692, 693	Martin, Mordaza universal	342, 343	Metzenbaum-TCC-BlackLine,	
Leyla, Cabeza de acoplamiento	691-693	Martin, Oliva	668	Tijera de disección	49, 55
Leyla, Dispositivo fijador	691	Martin, Pelvimetro	838	Metzenbaum-TCC-BlackLine-Fino,	
Leyla, Espátula cerebral	690	Martin, Pinza para cartílago	526	Tijera de disección	126
Leyla, Porta espátula con		Martin, Pinza para desechos	974	Metzenbaum-Thorek, Tijera de disección	127
vástago redondo	691-692	Martin, Pinza para vasos periféricos	600	Meyerding, Ganchito	244
Lichtenberg, Porta-agujas	418, 434	Martin, Pinza para vendajes	233	Michel, Agrafe de sutura	445
Ligador para hemorroides	776	Martin, Porta-agujas	427	Michel, Espejo laríngeo	941
Lillehei-Potts, Tijera de disección	123	Martin, Recipiente de óptica	342	Michel, Pinza aplicadora para agrafes	444
Lima para huesos	509-511, 917	Martin, Separador	254, 274	Micro Aguja auricular	860-861
Lima para uñas	951	Martin, Separador autoestático	321	Micro bisturi vascular	705
Lister, Pinza para vendajes	233	Martin, Sistema Brazo Martin	342	Micro Cucharilla	708, 863
Lister, Tijera para vendajes	450, 454	Martin, Vástago para tunelar	668	Micro Disecador	349, 705, 707, 862
Liston, Pinza cortante para hueso	545	Martin-Alloy, Diapasón	867	Micro Fleboextractor	349
Liston-Key, Pinza cortante para hueso	549	Martin-Aquajet, Tobera	972-973	Micro Ganchito	240, 708
Littauer, Pinza depilatoria	169	Martin-Aseptich, Cepillo para uñas	948	Micro Ganchito auricular	860-862
Littauer, Tijera para hilos	120	Martin-Cushing, Periestótomos	499	Micro Legra	706
Little, Separador	261	Martin-Fuchsig, Pinza para		Micro Legra auricular	879
Llave	380	preparación y ligadura	192	Micro Legra auricular	862
Llave	470	Martin-Hoen, Periestótomos	498	Micro Pinza	141, 153, 161-163, 165, 702
Llave de tres vías	380	Martini, Porta-agujas	430-431	Micro Pinza traumática	165
Llave horquilla	668	Martin-Langenbeck, Elevador	512	Micro Pinza auricular	848-853
Llave para aproximador	174	Martin-Langenbeck, Periestótomos	498	Micro pinza de dilatación	162
Lockhart-Mummary, Sonda para fístula	347	Martin-Rochard, Barra transversal	343	Micro Pinza de disección con ojal	162-163, 165
Locklin, Tijeras para encías	102	Martin-Rochard, Brazo de fijación	343	Micro Pinza para anudar	167
Lockwood, Pinza para intestinos y tejidos	751	Martin-Rochard, Garrucha	343	Micro Porta-Agujas	404-411, 418-423, 701
Logan, Separador autoestático	299	Martin-Rochard, Separador	343	Micro Sonda para medir	863
Lorenz, Tijera para vendajes	450	Martin-Rochard, Sistema de Retractores	343	Micro Tijera	79, 111-117, 698-700
Lorna, Pinza de campo	227	Martin-Rochard, Soporte para ganchos	343	Micro Tijera auricular	854-855
Lovelace, Pinza hemostática	191	Masing, Legra para tabique nasal	910	Micro Tijera de disección	116, 699
Lovelace, Pinza para coger el pulmón	590	Masson, Porta-agujas	415, 426	Microvascular, Porta-agujas	430
Lower, Pinza para preparación y ligadura	213	Mathieu, Pinza para cuerpos extraños	794	Middeldorff, Separador	267, 271
Lubet-Barbon, Pinza para taponamiento	890	Mathieu, Porta-agujas	417-418, 432-433	Middleton-Jansen, Pinza para tabique nasal	899
Lucae, Aguja para tímpano	878	Mathieu, Separador	297	Mikro-Adson, Pinza de disección	155
Lucae, Diapasón	868	Mayfield, Pinza gubia	540	Mikro-Adson, Pinza de disección con diente	155
Lucae, Ganchito auricular	877	Mayo, Imperdible para instrumentos	960	Mikro-Adson, Pinza hemostática	185
Lucae, Martillo	485	Mayo, Pinza de disección con diente	34-35, 158	Mikro-Friedman, Pinza gubia	538
Luer, Gancho traqueal	741	Mayo, Tijera de disección	34-35	Mikro-Hegemann, Tijera coronaria	82
Luer, Pinza gubia	539	Mayo-Blake, Pinza para cálculos biliares	782	Mikro-Mosquito, Pinza hemostática	188
Luer, Tubo de aspiración	360, 364	Mayo-Harrington, Tijera de disección	39	Mikulicz, Pinza para peritoneo	224-225
Lukens, Separador para timo	741	Mayo-Hegar, Porta-agujas	414, 425	Mikulicz, Separador	291
Luniatshchek, Taponeador	934	Mayo-Lexer TCC-BlackLine,		Mikulicz, Separador	290
		Tijera de disección	59	Mikulicz-Baby, Pinza para peritoneo	224
		Mayo-Lexer, Tijera de disección	127	Miller, Hoja de laringoscopia	387
		Mayo-Lexer-Aguila, Tijera de disección	59	Miller, Hoja de laringoscopia (luz fría)	396-397
		Mayo-Noble, Tijera de disección	39	Miller, Juego de laringoscopios	387
		Mayo-Robson, Pinza intestinal	756, 767	Miller, Juego de laringoscopios (luz fría)	396
		Mayo-Stille, Tijera de disección	36-38	Miller, Lima para alveolotomía	511

M

M. G. Hospital, Porta-agujas	414
Magacadora	916
Machill, Pinza para catéteres	386
Maltz, Escofina nasal	917, 919

Miller-Baby, Juego de laringoscopios	387
Miller-Colburn, Lima para huesos.....	510-511
Millesi, Micro Tijera	698
Milligan, Disecador para duramadre	688
Milligan, Separador autoestático	311
Millin, Dilatador para el cuello vesical	788
Millin, Pinza capsular	786-787
Millin, Pinza porta ligaduras	787
Millin, Separador vesical	789
Mini Clip vascular.....	175
Mini Flebextractor	349
Mini Glover, Pinza para preparación y ligadura	181
Mini-Adson, Pinza de disección con diente	155
Mini-Gemini, Pinza para preparación y ligadura	207
Mini-McGee, Micro Pinza auricular	849
Mixter, Pinza para cálculos biliares	783
Mixter, Pinza para preparación y ligadura	210-212
Mixter-Baby, Pinza para preparación y ligadura	185, 201, 209
Mixter-O'Shaugnessy, Pinza para preparación y ligadura	210
Mock, Aguja para heparin.....	376, 379
Mod. Bonn, Tijera para iridectomía.....	104
Mod. Martin, Pinza en tarro con tapa.....	960
Mod. Martin, Protector de cara	952
Mod. Martin, Sonda conductora.....	441
Mod. München, Cureta para biopsia.....	825
Mod. USA, Tijera umbilical.....	98
Mod. Wien, Espéculo nasal.....	886
Modell USA, Cucharilla cortante	494-495
Modell Wien, Porta-ligadura	443
Mogen, Instrumento para circuncisión	793
Moldenhauer, Elevador para cuerpos extraños	877
Mollison, Separador autoestático	308
Molt, Cureta cortante	497
Molt, Cureta de doble extremo	497
Mordaza universal	342, 343
Morris-De Bakey, Pinza aórtica	633
Morse, Separador esternal	563
Morse-Favaloro, Separador esternal	562
Moynihan, Pinza para histerectomía.....	222
Muehling, Periostótomo	502
Muelle de retención	882
Mueller, Clip vascular	179
Müller, Aproximador	172-173
Museux, Pinza para cuello uterino.....	819

N

Nabatoff, Cable de tracción	350
Nabatoff, Juego para varices.....	350
Nabatoff, Mango	350
Nabatoff, Oliva.....	350
Nabatoff, Punta plástica	350
Nagel, Micro Tijera	700
Nägele, Forceps obstétricos.....	838
Navaja.....	16
Neff, Cuchillo para menisco	520
Negus, Pinza hemostática	218
Neivert, Ganchito para alas de nariz.....	923
Neivert, Porta-agujas	412
Neivert-Anderson, Osteótomo	914
Nelaton, Sonda acanalada.....	347
Nelson, Pinza de disección con diente	159
Nelson, Trócar.....	358
Neuro, Diapasón	869
Norfolk-Norwich, Separador autoestático	302
Northbent, Tijera para hilos	119
Noto, Pinza para pólipos uterinos.....	821
Novak, Cureta aspiradora	825
Nuboer, Tubo de aspiración	372

O

Ochsner, Pinza aórtica	595
O'Connor, Ganchito de piel.....	241
Oehler, Pinza de disección con diente	146

Ogura, Pinza para piel	925
Oldberg, Pinza para hipófisis	732
Oliva	348, 350, 367, 668
Oliva auricular.....	881
Oliva metálica.....	882
Oliva nasal.....	881
Oliva uretral.....	380
Olivecrona, Disecador para duramadre.....	686-687
Olivecrona, Tijera para nervio trigémino	92
Olivecrona-Tönnis, Pinza para colocar grapas.....	685
Ollier, Separador	255
Olsen-Hegar, Porta-agujas	417, 431
O'Shaugnessy, Pinza para preparación y ligadura	210
Osteótomo.....	465, 468-469, 472-477, 480-481, 912-914
O'Sullivan-O'Connor, Separador abdominal.....	336
Otis, Cuchillo de repuesto	792
Otis, Uretrótomo.....	792
Overholt-Baby, Pinza para preparación y ligadura	190
Overholt-Fino, Pinza para preparación y ligadura	205-206
Overholt-Geissendörfer, Pinza para preparación y ligadura	204
Overholt-Martin, Pinza para preparación y ligadura	200
Overholt-Mini, Pinza para preparación y ligadura	206
Overholt-Mixter, Pinza para preparación y ligadura	201

P

Papavero-Caspar, Espéculo hipófisis.....	733
Parker, Separador	296
Parker-Langenbeck, Separador.....	297
Parker-Mott, Separador	296
Parkes, Osteótomo.....	914
Parte central con bola.....	880
Partsch, Cíncel.....	466
Partsch, Gubia	466
Partsch, Martillo.....	486
Pasador de tendones	521
Payr, Pinza intestinal para píloro.....	759
Payr, Sonda conductora	443
Payr-Baby, Pinza intestinal para píloro.....	759
Pea (Rochester), Pinza hemostática	196-197
Pea, Pinza hemostática	182, 193, 446-447
Pea-Nippon, Pinza hemostática	193
Peck-Joseph, Tijera para Face-lift.....	75
Pederson, Espéculo vaginal	799
Pedestal	868
Peers-Bertram modif., Pinza de campo	227
Peers-Bertram, Pinza de campo	228
Peet, Pinza para espinas	170
Pelvímetro	838
Penfield, Disecador para duramadre.....	689
Pennington, Elevador para tabique nasal	910
Pennington, Pinza hemostática	184
Pera de goma.....	881, 880
Pera de goma con valva	880
Percy, Retractor para amputación	535
Perforador	683
Perforador aórtico.....	557
Periostótomo	508
Periostótomo	498-506, 508
Pesas	869
Peso para espéculo vaginal.....	808-809
Pestalozza, Cucharilla para aborto.....	842
Phaneuf, Pinza para histerectomía	219
Piedra afiladora.....	119
Pierse, Micro Pinza.....	162
Pierse, Pinza micro con contrapeso	162
Pieza de acoplamiento	834
Pieza de succión	882
Pinza aórtica	595, 601-602, 606-609, 621, 624-625, 633, 655
Pinza aplicadora.....	612
Pinza aplicadora para agrafes	444

Pinza aproximadora	444
Pinza auricular.....	871
Pinza bronquial.....	587-588, 630
Pinza capsular	786-787
Pinza cortante para hueso.....	545-549, 874-875
Pinza cortante para laminectomía	712-723
Pinza cuticular.....	951
Pinza de campo	226-228, 446-447
Pinza de disección	138-147, 154-155, 160, 446-447
Pinza de disección atraumática	142, 147-148
Pinza de disección con diente	143-144, 146-147, 149-155, 157-160, 446-447
Pinza de disección con diente	158, 702-703
Pinza de disección vascular.....	610-611, 656
Pinza de drenaje	557
Pinza de relojero	156
Pinza de rodillos.....	230
Pinza de sujeción	704
Pinza depilatoria	169
Pinza en tarro con tapa	960
Pinza gastro-intestinales gemelas	763-764
Pinza gubia	536-544
Pinza hemostática	182-199, 218, 446-447, 594, 638
Pinza intercambiable	938-939
Pinza intestinal	754-758, 766-770
Pinza intestinal para píloro.....	759
Pinza micro con contrapeso.....	162, 164
Pinza nasal cortante	893-894, 896, 898
Pinza nasale	870
Pinza para aborto	840
Pinza para amígdalas	935, 937
Pinza para anastomosis intestinales	760, 762
Pinza para anastomosis rectales.....	770-773
Pinza para anastomosis.....	615, 631-632, 642, 657-658, 660, 662, 664
Pinza para aneurisma	634
Pinza para aneurisma de aórtica	619-620
Pinza para aplastamiento	899-900
Pinza para aplicar clips.....	172, 175
Pinza para aplicar y quitar agrafes	685
Pinza para aurícula.....	629
Pinza para biopsia.....	826-830
Pinza para biopsia rectal	777
Pinza para cabezal del maléolo.....	857
Pinza para cálculos biliares.....	782-783
Pinza para cálculos renales	780
Pinza para carótida.....	659
Pinza para cartílago	525-526
Pinza para catéteres	38, 604-605
Pinza para cerrar clamps.....	762
Pinza para cerrar grapas.....	760
Pinza para coarctación.....	613-614
Pinza para coger DIU	830
Pinza para coger el bocio	742
Pinza para coger el pulmón	590
Pinza para coger tendones.....	524
Pinza para coger tendones.....	523, 524
Pinza para colocar grapas.....	685
Pinza para columela	925
Pinza para conducto biliar.....	213, 216
Pinza para cortar uñas	954, 951
Pinza para cuello uterino	817-820
Pinza para cuerpos extraños	794
Pinza para desechos	974
Pinza para enderezar el tabique nasal	924
Pinza para entrelazar tendones	524
Pinza para espinas	166-168, 170
Pinza para esterilización	956
Pinza para etmoides.....	892-895
Pinza para Face-lift	185, 747
Pinza para hemorroides.....	777
Pinza para hígado.....	626
Pinza para hilos	185-186
Pinza para hipófisis	731-732
Pinza para histerectomía.....	219-221, 222-223
Pinza para huesos	525-527, 528-535
Pinza para iliaca.....	658

Pinza para intestinos y tejidos	750-754
Pinza para introducir	858
Pinza para la profunda.....	598
Pinza para ligaduras.....	615, 622-623
Pinza para microscopía.....	168
Pinza para oclusión tangencial.....	628
Pinza para pasar tendones.....	523
Pinza para pedículo renal.....	214-215
Pinza para peritoneo.....	224-225
Pinza para piel.....	925
Pinza para plegar alambre.....	856
Pinza para pólipos auriculares.....	872-873
Pinza para pólipos laringeos.....	942
Pinza para pólipos nasales.....	890
Pinza para pólipos uterinos.....	821
Pinza para preparación y ligadura	181, 185, 190, 192, 200-213, 217-218
Pinza para reposición.....	526, 528
Pinza para riñón y páncreas.....	627
Pinza para romper yeso.....	457
Pinza para sacar órganos.....	183-184, 732, 765
Pinza para shunt carótido.....	599
Pinza para tabique nasal.....	891, 899, 924
Pinza para taponamiento.....	890
Pinza para tapones.....	235-237, 446-447
Pinza para tubos.....	159, 228-229
Pinza para tunelar.....	234
Pinza para vasos.....	203, 627
Pinza para vasos periféricos.....	597, 600, 603, 616-617
Pinza para Vena Cava.....	625
Pinza para vendajes.....	233, 235
Pinza porta ligaduras.....	787
Pinza portasutura.....	706
Pinza sacabocado craneal.....	684
Pinza sacabocado para esfenoid.....	901-903
Pinza sacabocado para maxilar.....	897, 904
Pinza tangencial.....	214
Pinza tumor.....	702
Pinza uterina para hemostasis.....	840
Pinza vascular de usos múltiples.....	596, 618, 635-637, 639-642, 647-648, 650-654, 659-664
Pinza vascular para recién nacidos.....	675, 677
Pinza vascular pediátrica.....	643-646, 649, 657, 673-676
Pinzas para laminectomía.....	724-731
Piper, Forceps obstétricos.....	839
Pistola-lavatoria de chorro de agua.....	968
Pittsburgh, Pinza para hígado.....	626
Placa para extender la piel.....	17
Plaquita de silicona.....	959
Plester, Cuchillo para lóbulos.....	859
Plester, Separador autoestático.....	309
Plester, Tubo de aspiración.....	378
Pluma.....	322
Polipótomo.....	870, 888
Politzer, Aguja para paracentesis.....	878
Politzer, Aguja para tímpano.....	878
Politzer, Cono de conexión.....	881
Politzer, Insuflador de aire.....	881
Politzer, Oliva auricular.....	881
Politzer, Oliva nasal.....	881
Politzer, Pera de goma.....	881
Pollosón, Separador.....	283
Pollosón, Separador.....	284
Poole, Tubo de aspiración.....	368
Poppen, Tubo de aspiración.....	362
Porta espátula con vástago redondo.....	691-692
Porta-agujas.....	408, 411-420, 422-434, 436, 446-447
Porta-algodón.....	352
Porta-clamp.....	761
Porta-espátula.....	690-692
Porta-hoja / Rompe-hoja de afeitar.....	4
Porta-lazos.....	870
Porta-ligadura.....	443, 671
Potts, Micro Tijera.....	114
Potts, Pinza para anastomosis.....	615
Potts, Pinza para coarctación.....	613-614
Potts, Pinza vascular de usos múltiples.....	635
Potts-De Martell-Highmed, Tijera de disección.....	123
Potts-Smith, Pinza de disección.....	142, 145
Potts-Smith, Pinza de disección con diente.....	154
Potts-Smith, Tijera vascular.....	83
Pratt, Espéculo rectal.....	774
Pratt, Pinza hemostática.....	184
Price-Thomas, Pinza bronquial.....	587
Protector de cara.....	952
Protector suelto.....	952
Providence-Hospital, Pinza hemostática.....	188
Pulverizador.....	880
Punta cónica.....	882
Punta de botón.....	882
Punta de rosca.....	882
Punta de succión.....	362, 373
Punta plástica.....	350
Punta suelta.....	830
Punzón metálico.....	483
Putti, Escofina para hueso.....	482
Q	
Quattro, Separador para yeso.....	456
Quervain, Elevador.....	513
Quire, Elevador para cuerpos extraños.....	872
Quita-hojas.....	10
R	
Ragnell, Tijera de disección.....	135
Ragnell-Davis, Ganchito.....	245
Ralk, Pinza para espinas.....	170
Ramley, Pinza para tapones.....	237
Randall, Pinza para cálculos renales.....	780
Raney, Grapa para cuero cabelludo.....	685
Raney, Pinza para aplicar y quitar agrafes.....	685
Rascador para lupus.....	744
Rasse, Gancho para huesos.....	240
Rasse, Micro Ganchito.....	240
Recamier, Cureta uterina.....	832
Recipiente de descarga para cepillos.....	949
Recipiente de óptica.....	342
Record-Arkansas, Piedra afiladora.....	16
Redon, Aguja de guía.....	374-375
Rees, Tijera para Face-lift.....	131
Reiner, Cuchillo para yeso.....	455
Resano, Pinza de disección con diente.....	159
Resano, Pinza para anastomosis rectales.....	773
Retractor para amputación.....	535
Reverdin, Aguja de Reverdin.....	435
Reynolds, Tijera de disección.....	77-78
Reynolds, Tijera quirúrgica.....	78
Ricard, Bastidor, suelto.....	327
Ricard, Separador abdominal.....	327
Ricard, Valva central.....	327
Richardson, Separador.....	268
Richardson-Eastman, Separador.....	267
Richter, Pinza aplicadora para agrafes.....	444
Richter, Pinzas para laminectomía.....	731
Riñonera.....	965
Ritter-Halle, Dilatador para el seno maxilar.....	926
Robb, Disector vascular.....	670
Roberts, Pinza para preparación y ligadura.....	202
Rochester-Carmalt, Pinza hemostática.....	192
Roeder, Pinza de campo.....	227
Roger, Elevador para tabique nasal.....	910
Rogers, Pinza para histerectomía.....	221
Rose, Gancho traqueal.....	741
Rosen, Cuchillo para cortes redondos.....	859
Rosen, Micro Aguja auricular.....	860
Rosen, Micro Legra auricular.....	862
Rosenberg, Pinza intercambiable.....	939
Ross, Separador para aorta.....	281-282
Roux, Separador.....	294
Roux-Baby, Separador.....	295
Roux-Mini, Separador.....	295
Rubin, Caperuza protectora.....	900
Rubin, Osteótomo.....	913
Rubin, Pinza para aplastamiento.....	900
Rudd, Cono de carga.....	776
Rudd, Ligador para hemorroides.....	776
Rumel, Pinza para preparación y ligadura.....	208
Rumel-Belmont, Torniquete.....	671
Ruskin, Pinza gubia.....	540
Ruskin-Liston, Pinza cortante para hueso.....	547
Russ, Modell, Pinza de disección con diente.....	157
Rydel-Seiffert, Diapasón.....	869
Ryder (Martin), Porta-agujas.....	427
Ryder-Vascular, Porta-agujas.....	428
S	
Saalfeld, Extractor para comedones.....	746
Sachs, Disecador para duramadre.....	687
Sachs, Gancho para duramadre.....	696-697
Sachse, Calibre.....	794
Sachse, Meatótomo.....	794
Salenius, Cuchillo para menisco.....	520
Salpingógrafo.....	835
Salyer, Disecador para el paladar.....	932
Salyer, Elevador para el paladar.....	932
Salyer, Ganchito para el paladar.....	932
Salyer, Tijera de disección.....	72, 119
Samii, Bisturi tumor.....	704
Samii, Micro bisturi vascular.....	705
Samii, Pinza de sujeción.....	702
Sänger, Pinza para aborto.....	840
Santulli, Clamp Bulldog.....	592
Sanvenero, Tijera quirúrgica.....	72
Sarot, Pinza para preparación y ligadura.....	202
Sarot, Porta-agujas.....	425
Satinsky, Pinza para oclusión tangencial.....	628
Satinsky, Pinza para vasos.....	627
Satinsky, Tijera vascular.....	80
Sauerbruch, Costótomo.....	555
Sauerbruch, Estuche para agujas.....	957
Sauerbruch, Pinza gubia.....	544
Sauerbruch, Pinza para desechos.....	974
Sauerbruch, Separador.....	277, 280
Scalp-Contour, Separador autoestático.....	301
Schädel, Pinza de campo.....	226
Schamberg, Extractor para comedones.....	746
Schede, Cucharilla cortante.....	491
Scheibe, Pinza para coger órganos.....	765
Scheinmann, Pinza intercambiable.....	938
Scherbak, Espéculo vaginal.....	808
Scherbak, Mango para espéculo vaginal.....	807, 808
Scherbak, Peso para espéculo vaginal.....	808
Scherbak, Valva vaginal, suelta.....	807
Schink, Dermatómo.....	17
Schink, Hoja de repuesto.....	17
Schink, Placa para extender la piel.....	17
Schmeden, Pinza nasal cortante.....	898
Schmid, Cánula para irrigación vascular.....	379
Schmieden, Aguja para ligadura.....	436
Schmieden, Sonda conductora.....	442
Schmieden-Dick, Aguja para ligadura.....	436
Schmieden-Payr, Sonda conductora.....	442
Schmieden-Taylor, Tijera para duramadre.....	90
Schneider, Periostótomo.....	501
Schmidt, Pinza para amígdalas.....	935
Schmidt, Pinza para preparación y ligadura.....	192
Schröder, Pinza para cuello uterino.....	817-818
Schubert, Pinza para biopsia.....	826-827
Schuhmacher, Tijera umbilical.....	98
Schuknecht, Cuchillo de hoz.....	859
Schultze, Manómetro para salpingógrafo.....	835
Schultze, Salpingógrafo.....	835
Schumacher, Pinza intercambiable.....	939
Schumacher, Pinza para biopsia.....	829-830
Schumacher, Punta suelta.....	830
Scoville, Cucharilla cortante.....	493
Scoville, Gancho.....	341
Scoville, Separador para laminectomía.....	340
Scoville, Valva.....	341
Scoville-Haverfield, Separador para laminectomía.....	340
Scudder, Pinza intestinal.....	770

Sebileau, Elevador.....	513	Sonda845	Tijera de disección34-39, 47-56, 58-74,
Sedillot, Periostótomo.....	501, 504	Sonda abotonada346, 70875-78, 82, 91, 101, 119, 123-124,
Segond, Cuchillo para fibroma.....	822	Sonda acanalada.....347126-128, 130, 135, 446-447
Seiffert, Pinza intercambiable.....	938	Sonda auricular.....870	Tijera nasal.....63, 95-96
Sellheim, Elevador obstétrico.....	840	Sonda auricular.....346	Tijera para amígdalas.....93-94
Sellers, Aproximador para costillas.....	584	Sonda conductora.....440-443	Tijera para cortar hilos de acero.....121-122, 135
Semb, Periostótomo.....	508	Sonda conductora de tendones.....522	Tijera para disección de nervios.....56
Semb, Pinza bronquial.....	588	Sonda de mirto.....346	Tijera para duramadre.....90
Semb, Pinza cortante para hueso.....	549	Sonda filiforme.....791	Tijera para enucleación.....110
Semb, Pinza gubia.....	540	Sonda irrigadora para seno maxilar.....926	Tijera para episiotomía.....97
Semb, Pinza para huesos.....	529	Sonda metálica, femenina.....791	Tijera para estrabismo.....110
Semken, Pinza de disección.....	141	Sonda para bocio.....742	Tijera para Face-Lift.....57, 75, 119,
Semken, Pinza de disección		Sonda para fístula.....347131, 747-748
con diente.....	143, 152	Soporte de guía.....916	Tijera para ginecología.....40-41, 44-46
Semm, Espéculo vaginal.....	799	Soporte de luz fría.....775	Tijera para hilos.....99, 119-120, 124-125
Senn-Green, Ganchito.....	245	Soporte para espéculos auriculares.....865	Tijera para hysterectomía.....132-133
Senn-Miller, Ganchito.....	245	Soporte para ganchos.....343	Tijera para incisiones.....33
Separador.....	291	Sordina.....869	Tijera para incisiones.....118
Separador.....	249-275, 277-280,	Spencer, Tijera para hilos.....119-120	Tijera para iridectomía.....103-107
.....	283-291, 294-297, 343	Spencer-Wells, Pinza hemostática.....182	Tijera para nervio trigémino.....92
Separador abdominal.....	324-338	Spratt, Cucharilla cortante.....492	Tijera para neurocirugía.....90, 92
Separador autoestático.....	30, 298-323, 446-447	St. Barts, Pinza para etmoides.....895	Tijera para recto.....118
Separador costal.....	558-568, 573-576	St. Marks, Separador para pelvis.....292-293	Tijera para tendones.....108-109
Separador de hueso.....	710	St. Stacke, Sonda auricular.....346	Tijera para uñas.....950
Separador espinal.....	519	Stella-S, Tijera para Face-lift.....747	Tijera para vendajes.....450, 452, 454
Separador esternal.....	563	Stellbrink, Pinza gubia.....536	Tijera para yeso.....451-454
Separador grasa coronario.....	585	Stevens, Tijera para tendones.....108-109	Tijera quirúrgica.....20, 22, 24, 26, 28,
Separador nasal.....	921-923	Stevens, Tijera quirúrgica.....108-10930-37, 42-43, 73-74, 78, 100,
Separador para aorta.....	281-282	Stieglitz, Pinza para espinas.....170103, 108-109, 446-447
Separador para atrio.....	289	Stille, Cíncel.....468	Tijera umbilical.....80-84, 88-90, 107, 134
Separador para cuerpos vertebrales.....	710-711	Stille, Gubia.....469	Tijeras de micro para venas.....116
Separador para escápula.....	276	Stille, Osteótomo.....468-469	Tijeras para encías.....99, 101-102
Separador para esternotomía.....	558	Stille, Pinza de disección.....139	Tira-miomas.....822
Separador para laminectomía.....	340	Stille, Pinza de disección con diente.....151	Tobera.....972-973
Separador para pelvis.....	292-293	Stille, Pinza gubia.....540	Toennis, Discador para duramadre.....686
Separador para piloro.....	761	Stille-Barraya, Pinza de disección	Toennis, Porta-agujas.....418, 433
Separador para próstata.....	785	con diente.....157	Toennis, Tijera de disección.....91
Separador para rodilla.....	519	Stille-Liston, Pinza cortante	Toennis-Adson, Tijera de disección.....91, 129
Separador para timo.....	741	para hueso.....547-548	Tohoku, Pinza de campo.....227, 446-447
Separador para tiroides y vagina.....	323	Stille-Luer, Pinza gubia.....543	Tönnis-Adson TCC-BlackLine,
Separador para yeso.....	456	Stille-Martin, Cizalla para yeso.....453	Tijera de disección.....129
Separador rectal.....	775	Stille-Ruskin, Pinza gubia.....541	Tönnis-Adson-Aquila, Tijera de disección.....129
Separador torácico.....	570, 572, 579-580, 583	Stockmann, Clamp para pene.....795	Tornillo.....521
Separador vesical.....	788-789	Stone-Watt, Cierre para clamps intestinales...762	Tornillo de repuesto.....470
Set "Sutura pequeña".....	446	Stone-Watt, Pinza para anastomosis	Tornillo moleteado.....869
Sewall, Periostótomo.....	501	intestinales.....762	Torniquete.....671
Shaaf, Pinza para espinas.....	168	Stone-Watt, Pinza para cerrar clamps.....762	Toynbee, Espéculo auricular, juego.....864
Shambaugh, Micro Ganchito auricular.....	862	Strandell-Stille, Ganchito.....248	Trelat, Espéculo vaginal.....799
Shapleigh, Cureta auricular.....	876	Stratte, Porta-agujas.....416, 429-430	Trelat, Periostótomo.....500
Shea Vein Graft, Tijera de disección.....	75	Strauss, Clamp para pene.....795	Trépano para piel.....745
Shea, Ganchito explorador.....	862	Strully, Tijera para neurocirugía.....90	Trócar.....358
Sierra de hilo.....	682	Strümpel, Pinza para pólipos auriculares.....873	Tröltzsch (Wilde), Pinza auricular.....871
Sierra nasal.....	915	Struycken, Pinza nasal cortante.....896	Tröltzsch, Pinza para taponamiento.....890
Sierra oscilante para yeso.....	458	Subramanian, Pinza aórtica.....672	Trousseau, Dilatador traqueal.....740
Silver, Cíncel nasal.....	914	Subramanian-Miniature, Pinza aórtica.....672	Troutman-Chris, Porta-hoja /
Silver, Dermatomo.....	17	T	Rompe-hoja de afeitar.....4
Simon, Cucharilla cortante.....	493	Tabb, Cuchillo para mucosa.....859	Tubbs, Dilatador aórtico.....665
Simon, Cucharilla uterina.....	831	Takahashi, Pinza para etmoides.....892	Tubo de aspiración.....359, 363,
Simon, Gancho para fístulas.....	824	Tamiz para espéculo vaginal.....810366-368, 370-371
Simon, Separador.....	274	Tapa de repuesto.....486-488	Tubo de aspiración.....348, 360-363, 377-378
Simpson, Forceps obstétricos.....	838	Tapa para cobo para desechos.....974	Tubo de aspiración.....359, 361, 364-365,
Sims, Cureta uterina.....	832	Tapa para riñoneras.....965367-369, 372-373
Sims, Espéculo rectal.....	774	Taponeador.....934	Tubo de conexión.....795, 882
Sims, Espéculo vaginal.....	800	Tarro metálico.....964	Tubo de extensión.....830
Sims, Histerómetro.....	816	Tarro para instrumentos.....959	Tubo de laringeo.....937, 938, 939
Sims, Tijera para ginecología.....	40-41	Taylor, Pinza de disección.....141	Tuerca de mariposa.....775
Sims-Aquila, Tijera uterina.....	41	Taylor, Pinza de disección con diente.....153	Tuerca-hembra.....532, 969
Sims-Siebold, Tijera para ginecología.....	45	Taylor, Separador espinal.....519	Tuerce-lazos.....443
Sims-TCC-BlackLine, Tijera uterina.....	41	Taylor, Valva.....341	Tuffier, Pinza hemostática.....183
Singley-Tuttle, Pinza de disección		TCC-BlackLine, Tijera para	Tuffier, Separador costal.....563
con diente.....	158	histerectomía.....132-133	Tuohy, Aguja para punción lumbar.....377
Sistema Brazo Martin.....	342	Teale, Pinza para cuello uterino.....818	Turnbull, Pinza para cortar uñas.....950
Sistema de Retractores.....	343	tenedor tumor.....704	Tyding, Cierra-nudo para amígdalas.....936
Skene, Pinza para cuello uterino.....	818	Thoms-Allis, Pinza para intestinos y tejidos...751	
Smillie, Cuchillo para menisco.....	520	Thoms-Gaylor, Pinza para biopsia.....827	U
Smith-Petersen, Gubia.....	478	Thorek, Tijera de disección.....63	Ulrich, Pinza para huesos.....531
Smith-Petersen, Osteótomo.....	477	Tieck-Halle, Espéculo nasal.....885	Ulrich, Pinza para tapones.....232
Smithwick, Gancho para nervios.....	695	Tijera coronaria.....82, 85-87, 89	Universal, Pulverizador.....880
Snyder-O.S.U., Cíncel.....	464	Tijera cuticular.....951	Universal, Tijera para cortar hilos de acero.....121
Somer, Histerolabo.....	823		

Universal, Tijera para vendajes.....	452
Universal, Trócar	358
Unna, Extractor para comedones.....	746
Unna-Vidal, Extractor para comedones	746
Uretrótomo	792
V	
Valleix, Histerómetro.....	816
Valva.....	315-316, 337-339, 341
Valva central	312, 322, 325-327,330-336, 775, 789
Valva de alambre.....	335
Valva lateral.....	324-329, 558, 565-571,573-574, 577-582
Valva vaginal.....	801-805, 810
Valva vaginal, suelta	807
Válvula de conexión.....	882
Van Buren, Bujía uretral.....	790
Van Doren, Pinza para biopsia	828
Vannas, Micro Tijera	698
Varady, Flebextractor	349
Varady, Flebodisecador.....	349
Varady, Juego para varices.....	348
Varady, Micro Disecador	349
Varady, Micro Fleboextractor.....	349
Varady, Mini Flebextractor	349
Varady, Oliva	348
Vaso-medida	962
Vástago para tunelar	668
Veidenheimer, Pinza para anastomoses rectales.....	772
Verbrugge, Pinza para huesos	534, 535
Verhoeven, Tubo de aspiración	377
Verres, Cánula para insuflación.....	378
Vickers Low-Profile, Separador autoestático ..	322
Vickers Low-Profile, Valva central.....	322
Vickers, Separador autoestático	322
Vidal, Rascador para lupus.....	744
Vidrio de repuesto	949
Virchow, Cíncel rompe-cráneo.....	464
Virchow, Cuchillo para cerebro.....	3
Volkman, Cucharilla cortante	490, 491
Volkman, Cucharilla de doble extremo	496
Volkman, Separador.....	250-252
Vollmar, Cánula para irrigación vascular.....	378
Vollmar, Fleboextractor.....	351
W	
Wachenfeldt, Pinza aplicadora para agrafes ..	444
Wagener, Ganchito auricular	878
Wagner, Pinzas para laminectomía	730
Wagner, Tijera quirúrgica	100
Waldmann, Tijera para episiotomía.....	97
Walter, Gubia	913
Walter, Osteótomo	913
Wangensteen, Pinza de disección.....	146
Wangensteen, Porta-agujas.....	416, 428
Wassmund, Separador	256
Watson-Cheyne, Disector doble.....	513
Watson-Williams, Pinza para etmoides.....	893
Waugh, Pinza de disección.....	140
Waugh, Pinza de disección con diente.....	152
Weber, Pinza aórtica	624
Weber-Loch, Instrumento para cuerpos extraños	877
Webster, Porta-agujas	412, 419, 423-424
Weil, Pinza nasal cortante	893
Weil-Blakesley, Pinza nasal cortante.....	894
Weil-Blakesley, Pinza para etmoides.....	894-895
Weissbarth, Espéculo vaginal.....	810
Weissbarth, Tamiz para espéculo vaginal.....	810
Weitlaner, Separador autoestático	30, 303,306-307, 446-447
Weitlaner-Baby, Separador autoestático	311
Weitlaner-Wullstein, Separador autoestático...	308
Wertheim, Pinza para histerectomía	223
Wertheim, Tijera para ginecología.....	46
Wertheim-Cullen, Pinza vaginal.....	220
Westcott, Tijera para estrabismo	110
Westmacott, Pinza para taponamiento	890
White, Pinza para amígdalas.....	935
Wikstroem, Pinza para preparación y ligadura	211
Williams, Pinza para intestinos y tejidos	752
Williams, Separador autoestático	310
Williger, Cucharilla de doble extremo.....	497
Williger, Elevador	513
Williger, Martillo.....	484, 486
Williger, Perióstótomo	505
Winter, Pinza para aborto	840
Wolff, Cureta para lupus.....	744
Wolff, Pinza para romper yeso.....	457
Wrigley, Forceps obstétricos	838
Wullstein, Cuchillo de hoz.....	859
Wullstein, Micro Tijera auricular.....	855
Wullstein, Tubo de aspiración	363
Wylie, Pinza aórtica	601, 625
Y	
Yankauer, Cabezal para aspiración	367
Yankauer, Mango	367
Yankauer, Oliva	367
Yankauer, Tubo de aspiración.....	366, 367
Yasargil, Gancho Galea	686
Yasargil, Micro bisturi vascular	705
Yasargil, Micro Cucharilla.....	708
Yasargil, Micro Disecador	707
Yasargil, Micro Legra	706
Yasargil, Micro Pinza	702
Yasargil, Micro Porta-Agujas	701
Yasargil, Micro Tijera.....	699
Yasargil, Micro Tijera de disección.....	699
Yasargil, Pinza de sujeción	702
Yasargil, Pinza para hipófisis	731, 732
Yasargil, Pinza portasutura	706
Yasargil, Pinza tumor	702
Yasargil, tenedor tumor	704
Yasargil, Tubo de aspiración	365
Yasargil-Samii, Pinza de sujeción	702
Young, Aguja de repuesto.....	436
Young, Porta-agujas.....	436
Young, Separador para próstata.....	785
Z	
Zanger, Pinza aórtica	606
Zaufal, Elevador para cuerpos extraños.....	877
Zaufal-Jansen, Pinza gubia.....	539
Zeller, Gafa protectora	952
Zenker, Pinza para preparación y ligadura.....	209
Zenker, Separador	265
Zielke, Gubia	467
Zöllner, Espéculo auricular	865
Zöllner, Espéculo auricular, juego.....	865
Zöllner, Punta de succión.....	362
Zöllner, Tubo de aspiración.....	362
Zweifel, Porta-agujas	434

i

- A**
- Accumulateur inductif399, 400
 - Adaptateur792
 - Adaptateur à irrigation883
 - Adaptateur Luer668
 - Adaptateur pour cathéters380
 - Adlerkreutz, Pince à dissection à griffes151
 - Adson, Crochet pour dure-mère696
 - Adson, Ecarteur autostatique304-306, 313-314, 318
 - Adson, Elévateur510
 - Adson, Pince à dissection140, 144
 - Adson, Pince à dissection à griffes144, 152
 - Adson, Pince à disséquer et à ligatures192
 - Adson, Porte-aiguilles413
 - Adson, Tube d'aspiration360
 - Adson-Baby, Pince à disséquer et à ligatures201
 - Adson-Brown, Pince à dissection à griffes144, 155
 - Agrafes445
 - Agrafes pour cuir chevelu685
 - Aiguille à dissection402-403
 - Aiguille de rechange174
 - Aiguille pour amygdales364, 377
 - Aiguille pour héparine376, 379
 - Aiguille pour ponction du foie379
 - Aiguille pour ponction lombaire377
 - Aiguilles à ligatures436-440
 - Aiguilles de rechange436
 - Alan-Parks, Dilatateur rectal775
 - Alderdyce, Dissecteur double513
 - Alésoir683
 - Alexander, Ciseau-burin467
 - Alexander, Gouge467
 - Alexander, Pince pour biopsie829
 - Alexander, Rugine-raspatoire508
 - Allen, Pince intestinale758
 - Allenberg-Cobra, Pince vasculaire universelle664
 - Allis, Pince pour saisir intestins et tissus750-751
 - Allis-Adair, Pince pour saisir intestins et tissus751
 - Allis-Baby, Pince pour saisir intestins et tissus750
 - Allison, Spatule pulmonaire586
 - Alm, Ecarteur autostatique300
 - Amniotome817
 - Ampoule de rechange391, 398
 - Anderson-Adson, Ecarteur autostatique301
 - Anneaux en caoutchouc776
 - Anse en fil936
 - Anuscope774
 - Approximateur172-174
 - Approximateur pour nerfs174
 - Aquila, Ciseaux à hystérectomie132-133
 - Arruga, Micro porte-aiguilles408
 - Arruga, Porte-aiguilles411, 422
 - Articulation sphérique692, 693
 - Asch, Pince pour le redressement de la cloison nasale924
 - Aston, Ciseaux pour Face-lift57
 - Aufricht, Ecarteur nasal921, 923
 - Aufricht, Râpe pour la glabelle918
 - Austin, Dissecteur pour l'attique862
 - Austin, Micro-Pince à poser des ligatures167
 - Auvard, Spéculum vaginal809
 - Ayre, Bistouri pour le cône d'attraction824
 - Babcock, Pince pour saisir intestins et tissus752-753
 - B**
 - Baby-Adson, Pince hémostatique185
 - Baby-Poole, Tube d'aspiration368
 - Backhaus, Pince à champs226
 - Bailey, Rapprocheur des côtes584
 - Bailey-Baby, Rapprocheur des côtes584
 - Bailey-Gibbon, Rapprocheur des côtes584
 - Bainbridge, Pince vasculaire universelle618
 - Bakes, Dilatateur pour les voies biliaires781
 - Balfour, Ecarteur abdominal332-333
 - Balfour, Mod. USA, Ecarteur abdominal335
 - Balfour, Mod. USA, Valve en fil335
 - Balfour, Valve centrale332, 334-335
 - Balfour-Baby, Ecarteur abdominal331
 - Balfour-Standard, Ecarteur abdominal334
 - Ballenger, Bistouri pour la cloison nasale906
 - Ballenger, Gouge pour la cloison nasale911
 - Ballenger-Hajek, Elevateur pour la cloison nasale909
 - Bandeau frontal952
 - Barbara, Micro Aiguille auriculaire860-861
 - Barbara, Micro Crochet auriculaire860
 - Baron-Schuknecht, Tube d'aspiration363
 - Barraquer, Micro porte-aiguilles409, 423
 - Barraquer, Pince à épiler les cils169
 - Barraquer-Troutman, Micro porte-aiguilles408
 - Barre transversale343
 - Base de Bakelit869
 - Bassin rétroforme965
 - Beacham, Amniotome817
 - Beck, Pince vasculaire universelle642, 651
 - Beckman-Adson, Ecarteur autostatique319, 320
 - Beckmann, Couteaux à végétations adénoïdes926
 - Beckmann, Ecarteur autostatique317
 - Beebe, Ciseaux coupe-fil122
 - Beer, Pince à épiler les cils169
 - Bellucci, Micro Ciseaux auriculaires854
 - Bengolea, Pince hémostatique195
 - Bennett, Levier à os518
 - Benson, Ecarteur pour pylore761
 - Bergmann, Ciseaux pour plâtre451
 - Bergmann, Pince pour éponges236
 - Bernhard, Pince à champs227
 - Bethune, Costotome555
 - Beyer, Ostéotome emporte-pièces875
 - Beyer, Pincettes-gouges539
 - Biemer, Clip vasculaire172
 - Biemer, Micro-ciseaux pour les veines116
 - Biemer-Müller, Approximateur173
 - Billeau, Anse auriculaire877
 - Bircher-Ganske, Pincettes à cartilage525
 - Bistouri à amygdales933
 - Bistouri à dissection2
 - Bistouri à usage unique13-14
 - Bistouri et énucléateur pour amygdales933
 - Bistouri pour la cloison nasale906
 - Bistouri pour le cône d'attraction824
 - Bistouris à ménisque520
 - Blake, Curette utérine831
 - Blake, Pince pour calculs biliaires782
 - Blahmke, Pincettes pour amygdales935
 - Blount, Ecarteurs pour le genou519
 - Blumenthal, Pincettes-gouges538
 - Böhler, Pincettes coupantes à os546
 - Böhler, Pincettes-gouges539
 - Boîte intérieure958
 - Boîte pour aiguilles961-963
 - Boîte pour déposer les brosses à ongles949
 - Boîte pour instruments812, 968, 965
 - Bonney, Pince à dissection à griffes143, 158
 - Borowski, Ecarteur pour aorta282
 - Bougie conductrice791
 - Bougie urétrale790
 - Bouton de rechange868
 - Bowman, Sonde845
 - Boys-Allis, Pince pour saisir intestins et tissus751
 - Bozemann, Pince pour éponges235
 - Bozemann, Porte-aiguilles429
 - Bozemann, Tords-fil443
 - Bras de fixation343, 692-693
 - Bras flexible690, 691, 692
 - Braun, Dépresseur utérin816
 - Braun, Pince pour le col de l'utérus817, 820
 - Braun-Stadler, Ciseaux à épisiotomie97
 - Breisky, Spéculum vaginal810
 - Brom, Ecarteur pour veines248
 - Brompton, Pince à roulette230
 - Brophy, Pince à dissection à griffes153
 - Brosse à lavement974-977
 - Brosse à ongles948
 - Brown, Porte-aiguilles413
 - Brünings, Bistouri à amygdales933
 - Brünings, Embout interchangeable938
 - Brünings, Pince pour la cloison nasale891
 - Brünings, Serre-noeuds pour amygdales936
 - Brünings, Tube laryngien937, 938, 939
 - Brünings, Tube rallonge830
 - Brunner, Aiguilles à ligatures440
 - Brunner, Costotome556
 - Brunner, Ecarteur278-279
 - Brunner, Pince pour anastomoses rectales770
 - Brunner, Sondes conductrices440, 442
 - Bruns, Ciseaux pour plâtre452, 454
 - Bruns, Curette tranchante492-493
 - Buck, Ciseaux à ligatures120
 - Buck, Curette auriculaire876
 - Buck, Pince pour polypes auriculaires872
 - Buckley, Ecarteur autostatique299
 - Burford, Ecarteur de côtes560
 - Burin pour le crâne464
 - Busch, Ciseaux pour le cordon ombilical98
 - Bushe, Curette tranchante495
 - Byrd, Tube d'aspiration373
 - C**
 - Cable tracteur350
 - Calibre794
 - Calne, Pince pour Vena Cava625
 - Canule376
 - Canule à irrigation926
 - Canule pour anesthésie transvaginale376
 - Canule pour insufflation378
 - Canule pour irrigation vasculaire378-379
 - Canule veineuse376
 - Canules d'aspiration359, 363, 366-368, 370-371
 - Caplan, Pince pour la cloison nasale899
 - Capuchon protecteur900
 - Carpenter, Bistouri et énucléateur pour amygdales933
 - Caspar, Crochets à nerfs et à vaisseaux709
 - Caspar, Fourche à suture705
 - Caspar, Micro Dissecteur705
 - Caspar, Micro-Ciseaux700
 - Caspar, Pignons métalliques483
 - Caspar, Pincettes pour laminectomie724-729
 - Castañeda, Ecarteur de côtes561
 - Castañeda, Pince vasculaire pour nouveaux nés677
 - Castroviejo, Compas844
 - Castroviejo, Micro porte-aiguilles404-405, 410-411, 422-423
 - Castroviejo, Micro-Ciseaux111
 - Castroviejo, Pincette pour saisir et casser les lames de rasoir4
 - Castroviejo-Epker, Compas844
 - Castroviejo-Fino, Micro porte-aiguilles409
 - Cerullo, Tube d'aspiration365
 - Chaput, Pince hémostatique183
 - Chargeur inductif400
 - Cheattle, Pince pour instruments stérilisés956
 - Cheron, Pince à pansements235
 - Childe, Pince à poser les agrafes444
 - Cinelli, Ciseaux nasaux63
 - Cinelli, Ostéotome914
 - Cisaille à os554
 - Ciseau-burin464-468, 480, 913
 - Ciseau-burin à sternum556
 - Ciseau-burin nasal914
 - Ciseau-burin spongieuse471
 - Ciseaux à dissection34-39, 47-56, 58-74, 75-78, 82, 91, 101, 119, 123-124, 126-128, 130, 135, 446-447
 - Ciseaux à énucléation110
 - Ciseaux à épisiotomie97

- Ciseaux à gencives99, 101-102
Ciseaux à gynécologie.....40-41, 44-46
Ciseaux à hystérectomie.....132-133
Ciseaux à incision33
Ciseaux à iridectomie103-107
Ciseaux à ligatures99, 119-120, 124-125
Ciseaux à ongles950
Ciseaux à strabisme110
Ciseaux à ténotomie108-109
Ciseaux chirurgicaux.....20, 22, 24, 26, 28,30-37, 42-43, 73-74, 78,100, 103, 108-109,446-447
Ciseaux coronaires.....82, 85-87, 89
Ciseaux coupe-fil.....121-122, 135
Ciseaux nasaux63, 95-96
Ciseaux pour Face-lift57, 75, 119,131, 747-748
Ciseaux pour la dure-mère.....90
Ciseaux pour le cordon ombilical.....98
Ciseaux pour le nerf trigeminal92
Ciseaux pour les amygdales93-94
Ciseaux pour nerfs56
Ciseaux pour neurochirurgie90, 92
Ciseaux pour pansements.....450, 452, 454
Ciseaux pour plâtre.....451-454
Ciseaux pour rectum118
Ciseaux vasculaires80-84, 88-90
Ciseaux vasculaires.....83, 107, 134
Ciseaux-entérotomes.....118
Citelli, Pince pour polypes auriculaires874
Clamp ombilical842
Clamps Bulldog.....176-181, 589,590-592, 611-612
Clé.....470
Clé pour approximateur174
Cleveland, Pincés coupantes à os546
Cleveland, Pincés-gouges536
Clip de stérilisation960
Clip vasculaire172, 179
Cloward, Ecarteur autostatique315-316
Cloward, Ecarteurs pour corps vertébraux.....710
Cloward, Valve315-316
Coakley, Curette pour l'antré.....925
Cobb, Gouge479
Cobbs, Rugine-raspatoire503
Cogswell, Tube d'aspiration373
Collier, Porte-aiguilles.....412
Collin, Clamp ombilical.....842
Collin, Ecarteur abdominal.....324-326, 328-329
Collin, Maillet485
Collin, Manche pour bistouri.....6
Collin, Pince à pansements235
Collin, Pince à tumeurs à vis184
Collin, Pince hystérolabe.....823
Collin, Pince pour saisir organes184
Collin, Spéculum vaginal.....798
Collin-Baby, Ecarteur abdominal324, 327,328, 329
Collin-Hartmann, Ecarteur.....294
Combinaison couvercle/pince.....960
Compas844
Compas pour mesurer la longueur des vaisseaux.....604
Conducteur pour scie du fil métallique682
Cône793
Cône de charge776
Cone, Pince emporte-pièces crânienne684
Conteneur à piles398
Converse, Ciseaux nasaux.....96
Converse, Couteau pour plastie du nez905
Converse, Crochet pour les ailes du nez922
Converse, Ecarteur nasal922
Cooley, Dilatateur pour aorte.....665
Cooley, Dilatateur vasculaire666
Cooley, Ecarteur de côtes.....558-559
Cooley, Ecarteur oreilles.....582
Cooley, Ecarteur pour atrium289
Cooley, Pince à dissection vasculaire.....656
Cooley, Pince pour sondes605
Cooley, Pince vasculaire pédiatrique.....657
Cooley, Pince vasculaire universelle647-648,659-663
Cooley, Pince-clamps iliaque658
Cooley, Pince-clamps pour anastomose657-658, 660
Cooley, Pince-clamps pour aorte608-609, 621
Cooley, Pince-clamps pour carotide659
Cooley, Tube d'aspiration370-371
Cooley, Valves latérales573, 578
Cooley-Beck, Pince-clamps pour anastomose664
Cooley-Derra, Pince-clamps pour anastomose662, 664
Cooper, Aiguilles à ligatures437
Cordes, Embout interchangeable.....939
Coryllos, Ecarteur275
Costotome554-556
Cottle, Ciseaux nasaux95-96
Cottle, Couteau pour plastie du nez.....905
Cottle, Crochet nasal921
Cottle, Crochet pour les ailes du nez923
Cottle, Ecarteur nasal923
Cottle, Elevateur pour la cloison nasale909-910
Cottle, Elevateur pour le périoste910
Cottle, Elevateur sous forme de selle923
Cottle, Maillet485
Cottle, Manche.....916
Cottle, Ostéotome912
Cottle, Pince à columella925
Cottle, Pince pour saisir la peau925
Cottle, Pince-gouge à cartilage916
Cottle, Râpe nasale917
Cottle, Rugine-raspatoire.....501
Cottle, Spéculum nasal886-887
Cottle, Support conducteur pour ostéotomes916
Cottle-Kazanjian, Pincés coupantes à os545
Cottle-Neivert, Crochet pour les ailes du nez923
Cottle-Walsham, Pince pour le redressement de la cloison nasale.....924
Coupland, Manche pour tubes d'aspiration.....373
Coupland, Pointe de succion373
Couteau à amputation.....15
Couteau à cerveau3
Couteau à résection15
Couteau à tumeurs704
Couteau circulaire859
Couteau lobaire859
Couteau pour muqueuse859, 906
Couteau pour plastie du nez905
Couteau pour plâtre455
Couteaux à végétations adénoïdes.....926
Couteaux de truelle844
Couvercle pour bassin réiforme965
Couvercle pour seau pour déchets.....974
Crafoord, Pince à disséquer et à ligatures203
Crafoord, Pince vasculaires203
Crafoord-Sellors, Pince vasculaires.....203
Crile, Crochet pour les nerfs671
Crile, Pince hémostatique190
Crile, Porte-aiguilles.....417
Crile-Murray, Porte-aiguilles.....413
Crile-Rankin, Pince hémostatique191
Crile-Wood, Porte-aiguilles413, 419,424, 446-447
Crochet241-245, 248-249, 446-447
Crochet à exploration862
Crochet à nerfs.....695
Crochet à nerfs et à vaisseaux.....709
Crochet nasal921-922
Crochet nasal921
Crochet pour dure-mère696-697
Crochet pour Face-lift745
Crochet pour fistules824
Crochet pour la peau240-241, 745
Crochet pour les ailes du nez.....921-923
Crochet pour les nerfs.....671
Crochet pour palais932
Crochet valve583
Crutchfield, Pince de traction crânienne.....683
Curette497
Curette / crochet auriculaire877
Curette à aspiration825
Curette a avortement et placenta841, 842
Curette auriculaire.....877, 879, 880
Curette calculs biliaires784
Curette double496-497, 925
Curette pour biopsie825
Curette pour l'antré925
Curette pour les lupus.....744
Curette tranchante490-496
Curette utérine.....831-832, 834
Curette utérine.....831
Curettes d'aspiration834
Curseur869
CUSCO, Spéculum vaginal798
Cushing, Crochet.....245
Cushing, Crochet à nerfs695
Cushing, Ecarteur sous forme de selle246
Cushing, Pince à dissection.....142, 145
Cushing, Pince à dissection à griffes154
Cushing-Landolt, Spéculum hyphoph733
Cushing-Taylor, Pince à dissection145
Cuvette en acier inoxydable962
Cuvette ronde962
Cuzzi, Curette a avortement et placenta.....841
Cylindre de rechange381-384
Czerny, Pince pour le col de l'utérus.....820
Czerny, Spéculum rectal.....774
- D**
Dahlgren, Pince emporte-pièces crânienne684
Dale, Pince-clamps vasculaire périphérique597
Dandy, Pince hémostatique191
Dandy-Mosquito, Pince hémostatique191
Dardik, Pince vasculaire universelle596
Dartigues, Pince hystérolabe823
d'Assumpção, Pince pour Face-lift747
Daubenspeck, Curette tranchante491
Davidson, Ecarteur pour scapula.....276
Davies porte-os.....525-528, 529-535
Daviers porte-os526
Davis, Dissecteur à dure-mère688
Day, Crochet auriculaire878
De Bakey, Ciseaux à dissection62
De Bakey, Ciseaux coudés134
De Bakey, Ciseaux vasculaires82
De Bakey, Clamps Bulldog591
De Bakey, Dilatateur vasculaire.....667
De Bakey, Ecarteur de côtes565-568
De Bakey, Ecarteur seul565-568
De Bakey, Pince à dissection vasculaire610-611
De Bakey, Pince à disséquer et à ligatures.....615
De Bakey, Pince à ligatures622-623
De Bakey, Pince atraumatique à dissection147-148
De Bakey, Pince pour poser612
De Bakey, Pince vasculaire pédiatrique.....643
De Bakey, Pince vasculaire universelle618,636-637, 639-641, 650
De Bakey, Pince-clamps pour anastomose632
De Bakey, Pince-clamps pour anévrisme de l'aorte619-620
De Bakey, Pince-clamps pour aorte621, 655
De Bakey, Pince-clamps vasculaire périphérique616
De Bakey, Porte-aiguilles.....426
De Bakey, Tube d'aspiration.....366
De Bakey, Valves latérales565-569
De Bakey-Adson, Tube d'aspiration.....366
De Bakey-Bahnsen, Pince-clamps pour anévrisme634
De Bakey-Beck, Pince pour anastomose642

De Bakey-Derra, Pince vasculaire universelle652
 De Bakey-Diethrich, Clamps Bulldog178
 De Bakey-Mosquito,
 Pince hémostatique594, 638
 De Bakey-Pean, Pince hémostatique638
 De Bakey-Rankin, Pince hémostatique594
 De Bakey-Reynolds, Pince vasculaire universelle641
 De Bakey-Satinsky, Clamps Bulldog592
 De Bakey-Satinsky, Pince vasculaire universelle653
 De Martel, Conducteur pour scie du fil métallique682
 De Martel-Wolfson, Pince pour anastomoses intestinale760
 De Martel-Wolfson, Pince pour fermer les clamps760
 De Martel-Wolfson, Porte-clamps761
 De Vibliss, Pince emporte-pièces crânienne684
 Dean, Ciseaux pour les amygdales93-94
 Deaver, Ciseaux chirurgicaux33
 Deaver, Ecarteur286-288
 DeBaKey, Pince-clamps pour aorte602
 Dépresseur utérin816
 Derf, Porte-aiguilles412, 423
 Dermatome17
 Dermatome17
 Derra, Pince pour anastomose642
 Deschamps, Aiguilles à ligatures438-439
 Desjardins, Pince pour calculs biliaires783
 Desjardins, Pince pour les voies biliaires216
 Desmarres, Ecarteur sous forme de selle243
 Diapason870
 Diapason866-869
 Dieffenbach, Clamps Bulldog176
 Diethrich, Ciseaux vasculaires81, 84, 89
 Diethrich, Clamps Bulldog178
 Diethrich, Pince-clamps pour aorte595
 Diethrich-Salyer, Ciseaux à dissection82
 Dilatateur du col de l'utérus811-815
 Dilatateur pour aorte665
 Dilatateur pour la trachéotomie740
 Dilatateur pour le sinus frontal926
 Dilatateur pour les voies biliaires781
 Dilatateur rectal775
 Dilatateur vasculaire666-667
 Dilatateurs du col de l'utérus (jeu)812
 Dingmann, Pincés à cartilage525
 Dispositif au fixation690, 691
 Dissecteur à dure-mère686-689
 Dissecteur double513
 Dissecteur pour l'attique862
 Dissecteur pour palais932
 Dissecteur pour phlébite349
 Dissecteur vasculaire670
 Distributeurs de brosses948
 Douglas, Pince à épiler les cils169
 Doyen, Ciseaux à gynécologie44
 Doyen, Ecarteur273
 Doyen, Maillet484
 Doyen, Pince intestinale754, 766
 Doyen, Rugine pour le périoste costal507
 Doyen, Sonde cannelée347
 Doyen, Spéculum vaginal806
 Doyen, Tracteur pour myomes822
 Doyen, Valve vaginale810
 Doyen-Baby, Pince intestinale755, 766
 Doyen-Stille, Ecarteur269
 Dubost, Ecarteur seul570
 Dubost, Ecarteur thoracique570
 Dubost, Valves latérales570, 571
 Dunhill, Pince hémostatique189
 Duplay, Pince pour le col de l'utérus817
 Durante, Pince à dissection à griffes157
 Duval, Pince pour saisir intestins et tissus753-754

E

Ecarteur291
 Ecarteur249-275, 277-280, 283-291, 294-297, 343
 Ecarteur à os240
 Ecarteur à os710
 Ecarteur à sternotomie558
 Ecarteur à sternum563
 Ecarteur abdominal324-338
 Ecarteur autostatique30, 298-323, 446-447
 Ecarteur de côtes558-568, 573-576
 Ecarteur Galea686
 Ecarteur nasal921-923
 Ecarteur pour aorta281-282
 Ecarteur pour atrium289
 Écarteur pour graisse585
 Ecarteur pour laminectomie340
 Ecarteur pour le col de la vessie788
 Ecarteur pour le thymus741
 Ecarteur pour pelvis292-293
 Ecarteur pour pylore761
 Ecarteur pour scapula276
 Ecarteur pour thyroïde et vulva323
 Ecarteur pour trachéotomie741
 Ecarteur pour veines248
 Ecarteur prostatiques785
 Ecarteur sous forme de selle243, 246-247, 923
 Ecarteur thoracique570, 572, 579-580, 583
 Ecarteur vésical788-789
 Ecarteur, seul327, 337-339, 565-568, 570, 572-574, 579-581
 Ecarteurs pour corps vertébraux710-711
 Ecarteurs pour le genou519
 Ecarteurs spinaux519
 Echlin, Pincés-gouges541
 Ecraseur pour intestin759
 Ecrou à oreilles775
 Ecrou-raccord532, 969
 Eicken-Killian, Canule à irrigation926
 Eiselsberg, Ciseaux à ligatures120
 Élévateur510, 512-513
 Elevateur pour la cloison nasale907-910
 Élévateur pour le périoste910, 911
 Élévateur pour palais932
 Élévateurs pour amygdales933-934
 Embout à aspiration882
 Embout conique de raccordement881
 Embout de rinçage972-973
 Embout interchangeable938-939
 Embout pour veines668
 Embout, seul830
 Emmett, Crochet pour fistules824
 Endospéculum811
 Endospéculum811
 Enlève-lame10
 Esmarch, Ciseaux pour plâtre451
 Esmarch, Couteau pour plâtre455
 Etou, Ciseaux343
 Etou de maintien universel342, 343
 Eves, Serre-noeuds pour amygdales936
 Evideur de fibromes822
 Extracteur pour phlébite349
 Extracteur pour phlébite micro349
 Extracteur pour phlébite mini349

F

Fahlbusch, Micro-Ciseaux700
 Farabeuf, Davier porte-os530
 Farabeuf, Ecarteur295
 Farabeuf, Rugine-raspatoire502
 Farabeuf-Collin, Rugine-raspatoire502
 Farell, Porte-coton352
 Farrior, Spéculum auriculaire865
 Faulkner, Curette double925
 Faure, Pince pour biopsie826
 Faure, Pince pour le péritoine225
 Favalaro, Ciseaux vasculaires88, 90
 Fehland, Pince pour anastomose rectale772
 Feilchenfeld, Pince à échardes167

Fergusson, Canules d'aspiration361
 Fergusson, Daviers porte-os527
 Ferris-Smith-Kerrison, Pince emporte-pièces pour sinus sphénoïdal902
 Fil en acier871
 Filiform, Bougie conductrice791
 Finochietto (modif.), Ecarteur de côtes561
 Finochietto, Baby, Ecarteur de côtes564
 Finochietto, Ecarteur de côtes560, 564
 Finochietto, Infant, Ecarteur de côtes559
 Finochietto, Pince à disséquer et à ligatures213
 Finochietto, Porte-aiguilles415, 427
 Finsen, Ecarteur autostatique298
 Finsen-Martin, Ecarteur autostatique298
 Fisch, Micro Dissecteur862
 Fisher, Bistouri à amygdales933
 Flacon de rechange880
 Fomon, Ciseau-burin913
 Fomon, Ciseaux nasaux63, 95
 Fomon, Couteau pour plastie du nez905
 Fomon, Crochet pour les ailes du nez921-922
 Fomon, Râpe nasale918, 920
 Forceps obstétrique838-839
 Foregger, Jeu à laryngoscopie390
 Foregger, Jeu à laryngoscopie (lumière froide)394
 Foregger, Spatule à laryngoscopie390, 391
 Foregger, Spatule à laryngoscopie (lumière froide)395
 Förster, Pince pour éponges236-237
 Foster-Gillies, Porte-aiguilles432
 Fourche à tumeurs704
 Fox, Curette pour les lupus744
 Fraenkel, Embout interchangeable938
 Frazier, Crochet pour dure-mère697
 Frazier, Tube d'aspiration360-361
 Freeman, Ciseaux pour Face-lift748
 Freeman-Kaye, Ciseaux pour Face-lift748
 Freer, Bistouri pour la cloison nasale906
 Freer, Couteau pour muqueuse906
 Freer, Crochet pour la muqueuse922
 Freer, Elevateur pour la cloison nasale907-908
 Freer, Élévateur pour le périoste911
 Freer, Gouge pour la cloison nasale911
 French, Diapason866
 Friedmann, Pincés-gouges536
 Fritsch, Ecarteur272
 Frosch, Daviers porte-os527
 Frykholm, Pincés-gouges542
 Fuller, Pince pour introduction858
 Furonculotome878

G

Gallaher, Râpe pour antre917
 Gardner, Ciseau-burin464
 Gellhorn, Pince pour biopsie826
 Gelpi, Ecarteur autostatique323
 Gemini, Pince à disséquer et à ligatures207
 Gerald, Pince à dissection142
 Gerald, Pince à dissection à griffes143, 154
 Gerald, Pince atraumatique à dissection148
 Giertz-Stille, Costotome555
 Gigli, Manche à crochet682
 Gigli, Scie du fil métallique682
 Gillies, Erigne cutanée745
 Gillies, Pince à dissection à griffes143, 152
 Gillies, Porte-aiguilles417, 432
 Gillies-Mini, Porte-aiguilles432
 Gil-Vernet, Ecarteur sous forme de selle247
 Glover, Clamps Bulldog592, 612
 Glover, Pince vasculaire universelle640
 Glover, Pince-clamps pour anastomose631
 Gluck, Costotome554
 Gobelet pour instruments959
 Goelet, Ecarteur297
 Goldman-Fox, Ciseaux à gencives99
 Goldmann-Fox, Ciseaux pour ligatures99
 Goldsmith (Thudichum), Spéculum nasal884
 Good, Ciseaux pour les amygdales93

Goodell, Dilatateur du col de l'utérus811
 Gorney, Ciseaux pour Face-lift57, 131, 748
 Gosset, Ecarteur abdominal.....330-331
 Gosset-Baby, Ecarteur abdominal.....330
 Gouge464-467, 469, 472-473,
478-479, 481, 913
 Gouge pour la cloison nasale911
 Graefe, Ciseaux à iridectomie104
 Graefe, Micro Crochet240
 Graham, Crochet pour dure-mère696
 Graig, Pince pour la cloison nasale.....891
 Grant, Pince-clamps pour aorte.....607
 Grave, Spéculum vaginal.....799
 Green-Armytage, Pince utérine
 pour hémostase.....840
 Greene, Curette utérine.....834
 Gregory, Ciseaux pour Face-lift747
 Gregory, Micro porte-aiguilles420
 Gregory, Pince fémorale598
 Gregory, Pince pour carotide593
 Gregory, soft, Pince pour carotide593
 Groningen, Crochet à nerfs695
 Gross, Curette auriculaire877
 Gross-Maier, Pince à pansements.....234,
446-447
 Grünwald (Jansen), Pince à pansements890
 Grünwald, Pince à pansements890
 Grünwald, Pince auriculaire.....871
 Grünwald, Poire en caoutchouc.....880
 Guedel-Negus, Jeu à laryngoscopie388
 Guedel-Negus, Spatule à laryngoscopie388
 Guilen, Rugine-raspatoire à succion926
 Gunnar-Hey, Pince à roulette.....230
 Guthrie, Crochet pour la peau241
 Guttman, Spéculum vaginal.....799
 Guyon, Bougie urétrale790
 Guyon, Pince-clamps pour
 pédicules rénaux.....214-215

H
 Haberer, Spatule abdominale.....344
 Hach, Spatule pour fasciotomie669
 Haight, Ecarteur de côtes.....562
 Hajek, Pince emporte-pièces pour sinus
 sphénoïdal901
 Hajek-Kofler, Pince emporte-pièces
 pour sinus sphénoïdal901
 Halle, Curette tranchante495
 Halle, Elevateur pour la cloison nasale907
 Halsey, Porte-aiguilles.....412, 424
 Halsted-Mosquito,
 Pince hémostatique.....186-187, 446-447
 Hank, Dilatateur du col de l'utérus.....815
 Harken, Pince auriculaire629
 Harrington, Ecarteur285
 Hartmann, Diapason.....866-868, 870
 Hartmann, Ecarteur autostatique311
 Hartmann, Levier pour corps étrangers877
 Hartmann, Pince à polypes nasaux.....890
 Hartmann, Pince hémostatique.....186
 Hartmann, Pince nasale coupante.....898
 Hartmann, Pince pour amygdales.....937
 Hartmann, Pince pour polypes
 auriculaires.....872-873
 Hartmann, Pincettes-gouges.....537
 Hartmann, Spécula auriculaires (jeu)864
 Hartmann, Spéculum auriculaire864
 Hartmann-Halle, Spéculum nasal.....884
 Hartmann-Herzfeld, Pince pour polypes
 auriculaires.....873
 Hartmann-Hoffman, Pince pour polypes
 auriculaires.....873
 Hartmann-Wullstein, Levier pour corps
 étrangers873
 Hayes, Pince pour anastomose rectale.....771
 Heaney, Pince à hystérectomie219
 Heaney, Porte-aiguilles414, 426
 Hegar, Dilatateur du col de l'utérus.....812-814
 Hegar, Dilatateurs du col de l'utérus (jeu)812
 Hegar, Porte-aiguilles.....429

Hegar-Baumgartner, Porte-aiguilles413, 424
 Hegar-Vascular, Porte-aiguilles.....429
 Hegebenbarth, Pince à poser les agrafes444
 Heifetz, Pince saisir702
 Heifetz, Spatules.....694
 Heiming, Pince pour les calculs du bassin.....780
 Heiss, Pince à disséquer et à ligatures201
 Henckel-Tilley, Pince pour le nez870
 Henke, Elévateurs pour amygdales934
 Henley, Ecarteur autostatique.....312
 Henley, Valve centrale.....312
 Henly, Pince pour sondes604
 Hennig, Pince pour plâtre456
 Hepp-Scheidel, Micro porte-aiguilles.....419
 Hepp-Scheidel, Pince pour saisir
 les trompes.....159
 Heymann, Ciseaux nasaux.....96
 Heywood-Smith, Pince à polypes utérins821
 Hibbs, Ciseau-burin.....480
 Hibbs, Gouge481
 Hibbs, Ostéotome.....480-481
 Hohenfellner, Ciseaux à dissection61
 Hohman, mini, Levier à os514
 Hohmann, Levier à os.....515-517
 Hoke, Ostéotome.....480
 Hopkins, Couteau pour plâtre455
 Hösel, Ecarteur270
 House, Micro Curette863
 House, Micro Sonde pour mesurer863
 House, Tube d'aspiration369
 House-Dieter, Pince pour l'os marteau857
 Howarth, Elevateur pour la cloison nasale909
 Huber, Manche universel.....830
 Humby, Dermatome17
 Humby, Lame de rechange17
 Hunt, Pince saisir.....703
 Hunter, Pince à échardes168
 Hurd, Dissecteur/Rétracteur
 pour amygdales933
 Husfeldt, Pince-clamps vasculaires
 périphériques.....603
 Hystéromètre816

I
 Inge, Ecarteur à os710
 Inge, Ecarteurs pour corps vertébraux.....710-711
 Instrument de circoncision793
 Instrument de circoncision793
 Instrument pour passer les tendons.....521
 Instrument pour urétrographie793
 Instruments à écorcher les tendons.....521-522
 Insufflateur d'air881
 Iowa, Pince pour le col de l'utérus819
 Israel, Ecarteur257
 Iterson, Ecarteur pour trachéotomie741
 Ives-Fansler, Anuscope774

J
 JABOMA, Micro porte-aiguilles419
 JABOMA, Micro-Ciseaux.....117
 JABOMA, Pince à dissection.....147
 JABOMA, Pince à dissection à griffes.....147
 Jackson, Ecarteur pour trachéotomie.....741
 Jackson, Spéculum vaginal800
 Jacobs, Pince pour le col de l'utérus819
 Jacobson, Curette tranchante496
 Jacobson, Micro porte-aiguilles.....701
 Jacobson, Micro-Ciseaux114, 698
 Jacobson, Microcouteau vasculaire705
 Jacobson, Sonde boutonnée708
 Jameson, Ciseaux à dissection77
 Jamieson, Tube d'aspiration372
 Jamison, Porte-aiguilles415
 Janet, Cylindre de rechange384
 Janet, Seringue pour plaies et vessie.....384
 Jansen, Curette auriculaire.....877
 Jansen, Ecarteur autostatique.....300
 Jansen, Pince auriculaire871
 Jansen, Pincettes-gouges537
 Jansen, Rugine-raspatoire500

Javid, Pince pour carotide599
 Jeu à laryngoscopie387-390
 Jeu à laryngoscopie
 (lumière froide).....392, 394, 396
 Jeu de manicure pour infirmières.....950
 Jeu pour tunnéliser.....668
 Jeweler mod., Micr pince à dilater162
 Jeweler mod., Micro-Pince162
 Johns-Hopkins, Clamps Bulldog.....177
 Johnson, Porte-aiguilles416
 Joint de caoutchouc882
 Joll, Ecarteur pour thyroïde et vulva323
 Jones, Pince à champs226
 Jones-Martin, Pince à champs226
 Joseph, Ciseaux à dissection73-74
 Joseph, Ciseaux chirurgicaux73,74
 Joseph, Couteau pour plastie du nez905
 Joseph, Crochet nasal.....921-922
 Joseph, Elevateur pour la cloison nasale907
 Joseph, Elévateur pour le périoste.....910
 Joseph, Lime à os917
 Joseph, Scie nasale915
 Joseph-Masing, Elévateur pour le périoste910
 Jud-Allis, Pince pour saisir intestins
 et tissus751
 Judd-Masson, Ecarteur vésical.....788
 Jurasz, Pince pour polypes laryngiens.....942

K
 Kabierske, Curette auriculaire.....880
 Kabierske, Flacon de rechange880
 Kabierske, Lance-poudre.....880
 Kabierske, Poire en caoutchouc avec valve880
 Kader, Spatule abdominale293
 Kahre-Williger, Rugine-raspatoire505
 Kallmorgen, Spéculum vaginal.....805
 Kallmorgen, Valve vaginale805
 Kalt, Porte-aiguilles.....408
 Katsch, Tire-comédons.....746
 Kaye, Ciseaux pour Face-lift57, 119, 747
 Kaye, Crochet pour Face-lift745
 Kaye, Manche pour bistouri9
 Kaye-Millard, Crochet248
 Kelly, Ciseaux chirurgicaux.....42-43
 Kelly, Ecarteur268, 291
 Kelly, Pince à disséquer et à ligatures217
 Kelly, Pince à polypes utérins821
 Kelly, Pince hémostatique189
 Kelly, Sphinctroscope.....776
 Kelly-Rankin, Pince hémostatique.....190
 Kern, Davier porte-os529
 Kerrison, Pince emporte-pièces
 à laminectomie712-723
 Kerrison, Pince emporte-pièces
 pour sinus maxillaire904
 Kevorkian, Curette pour biopsie825
 Kevorkian, Pince pour biopsie.....829
 Key, Rugine-raspatoire503
 Keyes, Trépan cutané.....745
 Kielland, Forceps obstétrique839
 Kielland-Luikart, Forceps obstétrique839
 Killian, Elevateur pour la cloison nasale909
 Killian, Gouge pour la cloison nasale.....911
 Killian, Spéculum nasal885
 Killian-Claus, Gouge pour la cloison nasale.....911
 Kilner, Ciseaux à dissection76
 Kilner, Crochet pour les ailes du nez922
 Kilner, Erigne cutanée745
 Kilner, Porte-aiguilles423
 Kirschner, Cadre, seul.....337-339
 Kirschner, Ecarteur abdominal.....337-338
 Kirschner, Sondes conductrices441-442
 Kirschner, Valve337-339
 Klapp, Ecarteur249
 KLING-EX, Enlève-lame10
 Knight, Pince pour la cloison nasale.....891
 Knowles, Ciseaux pour pansements.....450
 Knutson, Instrument pour urétrographie793
 Knutson-Koch, Cône793
 Kocher (Ochsner), Pince hémostatique...198-199

Kocher, Ecarteur253, 262, 266, 273
 Kocher, Pince hémostatique194, 446-447
 Kocher, Pince intestinale757-758, 768-769
 Kocher, Spatule à goitre742
 Kocher-Langenbeck, Ecarteur263-264
 Kocher-Nippon, Pince hémostatique194
 Koenig, Rugine-raspatoire500
 Kogan, Endospéculum811
 König, Diapason869
 König, Sondes conductrices442
 Koos, Microcouteau vasculaire705
 Körte, Ecarteur256
 Krause, Embout interchangeable939
 Krause, Sonde auriculaire870, 888
 Krause-Voss, Serre-noeuds870, 888
 Krayenbühl, Crochet à nerfs et à vaisseaux709
 Krenkel, Raspatoire pour palais907
 Kressner, Pince pour la cloison nasale924
 Kristeller, Spéculum vaginal801-804
 Kronecker, Aiguilles à ligatures437

L

La Grange, Ciseaux à gencives101
 Laborde, Dilatateur pour la trachéotomie740
 Lahey, Ecarteur261
 Lahey, Pince à goitre742
 Lahey, Pince pour les voies biliaires213
 Lambert-Kay, Pince vasculaire universelle654
 Lambert-Kay, Pince-clamps pour anastomose632
 Lambotte, Ostéotome475-476
 Lambotte, Rugine-raspatoire508
 Lambotte-Mini, Ostéotome474
 Lame ciseau-burin, interchangeable470
 Lame de bistouri, (non-stériles)10-11
 Lame de rechange17, 453, 792
 Lame de scie10, 458
 Lame-gouge, interchangeable470
 Lame-ostéotome, interchangeable470
 Lames de rasoir4
 Lance-poudre880
 Landolt, Pince pour saisir tumeurs732
 Landolt, Rugine-raspatoire500
 Landolt, Tube d'aspiration365
 Lane, Davier porte-os533
 Lane, Pince à champs228
 Lane, Pince stomacales et intestinales jumelées763-764
 Lange, Crochet pour les ailes du nez921
 Lange, Embout interchangeable938
 Lange-Hohmann, Levier à os517
 Langenbeck, Couteau à résection15
 Langenbeck, Daviers porte-os527
 Langenbeck, Ecarteur258-260
 Langenbeck, Elévateur512
 Langenbeck, Ostéotome emporte-pièces876
 Langenbeck, Porte-aiguilles434
 Langenbeck, Rugine-raspatoire500
 Langenbeck-Green, Ecarteur260
 Langenbeck-Mini, Crochet243
 Lawrence, Pince à disséquer et à ligatures218
 Lazar, Micro-Pince à poser des ligatures167
 Lebsche, Ciseau-burin à sternum556
 Lees, Pince-clamps à bronches630
 Leksell-Stille, Pincés-gouges542
 Leland-Jones, Pince-clamps vasculaire périphérique617
 Lempert, Pincés-gouges537
 Lempert, Rugine-raspatoire auriculaire879
 Leriche, Pince hémostatique188
 Lessiveuse880
 Levier à os514-519
 Levier obstétrique840
 Levier pour corps étrangers877-878
 Lewin, Daviers porte-os526
 Lewis, Râpe nasale918
 Lexer, Ciseau-burin spongieuse471
 Lexer, Ciseaux à dissection58, 60, 127
 Lexer, Gouge473
 Lexer, Ostéotome473

Lexer-Baby, Ciseaux à dissection64
 Lexer-Fino, Ciseaux fins à dissection65
 Lexer-Mini, Gouge472
 Lexer-Mini, Ostéotome472
 Leyla, Articulation spherique692, 693
 Leyla, Bras de fixation692, 693
 Leyla, Dispositif au fixation691
 Leyla, Spatules cérébrales690
 Leyla, Support avec tige ronde691-692
 Leyla, Tête de accouplement691-693
 Lichtenberg, Porte-aiguilles418, 434
 Ligateur pour hémorroïdes776
 Lillehei-Potts, Ciseaux à dissection123
 Lime à os509-511, 917
 Limes à ongles951
 Lister, Ciseaux pour pansements450, 454
 Lister, Pince Sinus233
 Liston, Pincés coupantes à os545
 Liston-Key, Pincés coupantes à os549
 Littauer, Ciseaux à ligatures120
 Littauer, Pince à épiler les cils169
 Little, Ecarteur261
 Lockhart-Mummery, Sonde pour fistule347
 Locklin, Ciseaux à gencives102
 Lockwood, Pince pour saisir intestins et tissus751
 Logan, Ecarteur autostatique299
 Lorenz, Ciseaux pour pansements450
 Lorna, Pince à champs227
 Lovelace, Pince hémostatique191
 Lovelace, Pince-clamps à poumons590
 Lower, Pince à disséquer et à ligatures213
 Lubet-Barbon, Pince à pansements890
 Lucae, Aiguille pour le tympan878
 Lucae, Crochet auriculaire877
 Lucae, Diapason868
 Lucae, Maillet485
 Luer, Ecarteur pour trachéotomie741
 Luer, Pincés-gouges539
 Luer, Tube d'aspiration360, 364
 Lukens, Ecarteur pour le thymus741
 Lunettes protectrices952
 Luniatschek, Porte-tampon934

M

M. G. Hospital, Porte-aiguilles414
 Magill, Pince pour introduire les sondes386
 Maillet484-489
 Maintien pour écarteur343
 Maltz, Râpe nasale917, 919
 Manche351, 367, 916
 Manche à accumulateur inductif392, 394, 396, 399
 Manche à crochet682
 Manche à pile391
 Manche à pile392, 394, 396, 398
 Manche pour bistouri5-9, 12, 446-447
 Manche pour bistouri à tête pivotante6
 Manche pour miroir laryngien941
 Manche pour spéculum vaginal807, 808
 Manche pour tubes d'aspiration373
 Manche tracteur350
 Manche universelle668, 830
 Manomètre pour salpingographe835
 Marquard, Pincés-gouges540
 Martel-Rees, Pince pour Face-lift185
 Martin Aquajet, Pistolet-laveur à jet d'eau968
 Martin, Adaptateur Luer668
 Martin, Compas pour mesurer la longueur des vaisseaux604
 Martin, Couteau pour plâtre455
 Martin, Diapason867
 Martin, Distributeurs de brosses948
 Martin, Ecarteur254, 274
 Martin, Ecarteur autostatique321
 Martin, Embout pour veines668
 Martin, Etau de maintien universel342, 343
 Martin, Jeu pour tunnéliser668
 Martin, Manche universelle668
 Martin, Olive668

Martin, Pelvimètre838
 Martin, Pince à pansements233
 Martin, Pince pour déchets974
 Martin, Pince-clamps vasculaires périphériques600
 Martin, Pincés à cartilage526
 Martin, Porte-aiguilles427
 Martin, Spatule abdominale344
 Martin, Spéculum nasal885
 Martin, Support d'optique342
 Martin, Système Bras Martin342
 Martin, Tige pour tunnéliser668
 Martin, Tournevis668
 Martin-Alloy, Diapason867
 Martin-Aquajet, Embout de rinçage972-973
 Martin-Aseptic, Brosse à ongles948
 Martin-Cushing, Rugine-raspatoire499
 Martin-Fuchsig, Pince à disséquer et à ligatures192
 Martin-Hoen, Rugine-raspatoire498
 Martini, Porte-aiguilles430-431
 Martin-Langenbeck, Elévateur512
 Martin-Langenbeck, Rugine-raspatoire498
 Martin-Rochard, Barre transversale343
 Martin-Rochard, Bras de fixation343
 Martin-Rochard, Ecarteur343
 Martin-Rochard, Etau343
 Martin-Rochard, Maintien pour écarteur343
 Martin-Rochard, Système d'écarteurs343
 Masing, Elévateur pour le périoste910
 Masque protectrice952
 Masson, Porte-aiguilles415, 426
 Mathieu, Ecarteur297
 Mathieu, Pince pour corps étrangers794
 Mathieu, Porte-aiguilles417-418, 432-433
 Mayfield, Pincés-gouges540
 Mayo, Ciseaux à dissection34-35
 Mayo, Clip de stérilisation960
 Mayo, Pince à dissection à griffes34-35, 158
 Mayo-Blake, Pince pour calculs biliaires782
 Mayo-Harrington, Ciseaux à dissection39
 Mayo-Hegar, Porte-aiguilles414, 425
 Mayo-Lexer TCC-BlackLine, Ciseaux à dissection59
 Mayo-Lexer, Ciseaux à dissection127
 Mayo-Lexer-Aquila, Ciseaux à dissection59
 Mayo-Noble, Ciseaux à dissection39
 Mayo-Robson, Pince intestinale756, 767
 Mayo-Stille, Ciseaux à dissection36-38
 Mayo-Stille, Ciseaux chirurgicaux36-37
 McDonald, Dissecteur double513
 McGee, Micro Crochet auriculaire861
 McGee, Pince à plier les fils d'acier856
 McGinvey, Pincés-clamps pour hémorroïdes777
 McIndoe, Ciseaux pour neurochirurgie92
 McIndoe, Pince à dissection140, 143
 McIntosh, Jeu à laryngoscopie389
 McIntosh, Jeu à laryngoscopie (lumière froide)392
 McIntosh, Spatule à laryngoscopie389
 McIntosh, Spatule à laryngoscopie (lumière froide)392-393
 McKenty, Elevateur pour la cloison nasale 907-908
 McKenzie, Pince pour poser les agrafes685
 McQuigg-Mixer, Pince à disséquer et à ligatures212
 Mead, Maillet486
 Mead, Pincés-gouges537
 Méatotome794
 Meeker, Pince à disséquer et à ligatures218
 Menghini, Aiguille pour ponction du foie379
 Mesure graduée962
 Metzenbaum, Ciseaux à dissection47-48, 50-54, 56, 67, 70, 446-447
 Metzenbaum, Porte-aiguilles413
 Metzenbaum-Aquila, Ciseaux à dissection49, 55
 Metzenbaum-Aquila-Fino, Ciseaux à dissection67, 70

Metzenbaum-Fino, Ciseaux fins
à dissection66-71, 128, 130
Metzenbaum-Lahey, Ciseaux à dissection.....128
Metzenbaum-Nelson, Ciseaux
à dissection52-54
Metzenbaum-TCC-BlackLine,
Ciseaux à dissection49, 55
Metzenbaum-TCC-BlackLine-Fino,
Ciseaux à dissection126
Metzenbaum-Thorek, Ciseaux à dissection127
Meyerdig, Crochet244
Michel, Agrafes445
Michel, Miroir laryngien941
Michel, Pince à poser les agrafes444
Michel, Pince à poser les agrafes444
Micr pince à dilater162
Micro Aiguille auriculaire860-861
Micro Ciseaux auriculaires.....854-855
Micro Crochet240, 708
Micro Crochet auriculaire860-862
Micro Curette708, 863
Micro dissecteur.....349, 705, 707, 862
Micro Pince auriculaires848-853
Micro porte-aiguilles.....404-411,
.....418-423, 701
Micro Rugine-Raspatoire706
Micro Rugine-Raspatoire auriculaire.....862
Micro Sonde pour mesurer863
Micro-Ciseaux79, 111-117, 698-700
Micro-Ciseaux à dissection116, 699
Micro-ciseaux pour les veines116
Microcouteau vasculaire705
Micro-Ecarteur pour vaisseaux242
Micro-Pince141, 153, 161-163, 165, 702
Micro-Pince à dissection à anneau..162-163,165
Micro-Pince à poser des ligatures.....167
Micro-Pince atraumatique à dissection165
Microvasculaire, Porte-aiguilles430
Middeldorp, Ecarteur267, 271
Middleton-Jansen, Pince pour la
cloison nasale899
Mikro-Adson, Pince à dissection155
Mikro-Adson, Pince à dissection à griffes.....155
Mikro-Adson, Pince hémostatique185
Mikro-Friedman, Pincettes-gouges538
Mikro-Hegemann, Ciseaux coronaires82
Mikro-Mosquito, Pince hémostatique.....188
Mikulicz, Ecarteur291
Mikulicz, Ecarteur290
Mikulicz, Pince pour le péritoine224-225
Mikulicz-Baby, Pince pour le péritoine.....224
Miller, Jeu à laryngoscopie387
Miller, Jeu à laryngoscopie (lumière froide)396
Miller, Limes pour alvéolotomie511
Miller, Spatule à laryngoscopie387
Miller, Spatule à laryngoscopie
(lumière froide)396-397
Miller-Baby, Jeu à laryngoscopie387
Miller-Colburn, Lime à os510-511
Millesi, Micro-Ciseaux698
Milligan, Dissecteur à dure-mère.....688
Milligan, Ecarteur autostatique311
Millin, Ecarteur pour le col de la vessie788
Millin, Ecarteur vésical789
Millin, Pince porte-fil.....787
Millin, Pince pour saisir les capsules.....786-787
Mini Glover, Pince à disséquer
et à ligatures.....181
Mini-Adson, Pince à dissection à griffes155
Mini-clip vasculaire175
Mini-Gemini, Pince à disséquer
et à ligatures.....207
Mini-McGee, Micro Pince auriculaires849
Miroir laryngien940-941
Mixer, Pince à disséquer et à ligatures ..210-212
Mixer, Pince pour calculs biliaires.....783
Mixer-Baby, Pince à disséquer et
à ligatures185, 201, 209
Mixer-O'Shaughnessy, Pince à disséquer
et à ligatures.....210

Mock, Aiguille pour héparine376, 379
Mod. Bonn, Ciseaux à iridectomie.....104
Mod. Martin, Combinaison couvercle/pince ...960
Mod. Martin, Protecteur facial952
Mod. Martin, Sondes conductrices441
Mod. München, Curette pour biopsie.....825
Mod. USA, Ciseaux pour
le cordon ombilical98
Mod. Wien, Spéculum nasal886
Modell USA, Curette tranchante494-495
Modell Wien, Porte-ligature443
Mogen, Instrument de circoncision793
Moldenhauer, Anse auriculaire.....877
Mollison, Ecarteur autostatique308
Molt, Curette497
Molt, Curette double.....497
Morris-De Bakey, Pince-clamps pour aorte633
Morse, Ecarteur à sternum563
Morse-Favaloro, Ecarteur à sternum562
Moynihan, Pince à hystérectomie.....222
Muehling, Rugine-raspatoire.....502
Mueller, Clip vasculaire.....179
Müller, Approximateur172-173
Museux, Pince pour le col de l'utérus819

N
Nabatoff, Cable tracteur.....350
Nabatoff, Manche tracteur350
Nabatoff, Olive.....350
Nabatoff, Pointe en plastique.....350
Nabatoff, Trousse à varices.....350
Nagel, Micro-Ciseaux700
Nägele, Forceps obstétrique838
Neff, Bistouris à ménisque520
Negus, Pince hémostatique.....218
Neivert, Crochet pour les ailes du nez923
Neivert, Porte-aiguilles412
Neivert-Anderson, Ostéotome914
Nelaton, Sonde cannelée347
Nelson, Pince à dissection à griffes.....159
Nelson, Trocart.....358
Neuro, Diapason869
Norfolk-Norwich, Ecarteur autostatique302
Northbent, Ciseaux à ligatures119
Noto, Pince à polypes utérins821
Novak, Curette à aspiration825
Nuboer, Tube d'aspiration.....372

O
Obtuteur926
Ochsner, Pince-clamps pour aorte595
O'Connor, Crochet pour la peau241
Oehler, Pince à dissection à griffes146
Ogura, Pince pour saisir la peau925
Oldberg, Pince pour hypophyse.....732
Olive348, 350, 367, 668
Olive auriculaire881
Olive en métal.....882
Olive nasale.....881
Olive urétrale380
Olivecrona, Ciseaux pour le nerf trigéminal92
Olivecrona, Dissecteur à dure-mère686-687
Olivecrona-Tönnis, Pince pour poser
les agrafes685
Ollier, Ecarteur255
Olsen-Hegar, Porte-aiguilles417, 431
O'Shaughnessy, Pince à disséquer
et à ligatures.....210
Ostéotome465, 468-469, 472-477,
.....480-481, 912-914
Ostéotome emporte-pièces876
O'Sullivan-O'Connor, Ecarteur abdominal336
Otis, Couteau de rechange792
Otis, Urétrotome.....792
Overholt-Baby, Pince à disséquer
et à ligatures.....190
Overholt-Fino, Pince à disséquer
et à ligatures.....205-206
Overholt-Geissendörfer, Pince à disséquer
et à ligatures.....204

Overholt-Martin, Pince à disséquer
et à ligatures.....200
Overholt-Mini, Pince à disséquer
et à ligatures.....206
Overholt-Mixer, Pince à disséquer
et à ligatures.....201

P
Papavero-Caspar, Spéculum hyphoph733
Parker, Ecarteur296
Parker-Langenbeck, Ecarteur297
Parker-Mott, Ecarteur.....296
Parkes, Ostéotome.....914
Partie moyenne avec balle.....880
Partsch, Ciseau-burin466
Partsch, Gouge.....466
Partsch, Maillet.....486
Payr, Ecraseur pour intestin.....759
Payr, Sondes conductrices.....443
Payr-Baby, Ecraseur pour intestin.....759
Pean (Rochester), Pince hémostatique ...196-197
Pean, Pince hémostatique.....182, 193, 446-447
Pean-Nippon, Pince hémostatique193
Peck-Joseph, Ciseaux pour Face-lift75
Pederson, Spéculum vaginal.....799
Peers-Bertram modif., Pince à champs.....227
Peers-Bertram, Pince à champs228
Peet, Pince à échardes170
Pelvimètre838
Penfield, Dissecteur à dure-mère689
Pennington, Elevateur pour la
cloison nasale910
Pennington, Pince hémostatique.....184
Percy, Retracteur pour amputation535
Pestalozza, Curette a avortement
et placenta842
Phaneuf, Pince à hystérectomie.....219
Pièce de raccordement834
Pierre à aiguiser16
Pierse, Micro-Pince162
Pierse, Pince micro avec contrepoids162
Pilons métalliques483
Pince à champs226-228, 446-447
Pince à columella.....925
Pince à dissection138-147, 154-155,
.....160, 446-447
Pince à dissection à griffes143-144,
.....146-147, 149-155,
.....157-160, 446-447, 702-703
Pince à dissection vasculaire.....610-611, 656
Pince à disséquer et à ligatures181, 185,
.....190, 192, 200-213,
.....217-218, 615
Pince à échardes.....168, 166-168, 170
Pince à épiler les cils.....169
Pince à goitre.....742
Pince à hystérectomie ...219-220, 221, 222-223
Pince à ligatures185-186, 622-623
Pince à microscopie168
Pince à pansements235, 890
Pince à plier les fils d'acier856
Pince à polypes nasaux890
Pince à polypes utérins821
Pince à poser les agrafes.....444
Pince à roulette.....230
Pince à tampons232-234, 446-447
Pince à tumeurs702
Pince à tumeurs à vis184, 732
Pince atraumatique à dissection142, 147-148
Pince auriculaire629
Pince d'horloger156
Pince de drainage557
Pince de traction crânienne.....683
Pince emporte-pièces à laminectomie712-723
Pince emporte-pièces crânienne684
Pince emporte-pièces pour sinus
maxillaire897, 904
Pince emporte-pièces pour sinus
sphénoïdal.....901-903
Pince éthmoïdale892-895
Pince fémorale.....598

- Pince hémostatique.....182-199, 218, 446-447, 594, 638
Pince hystérolabe.....823
Pince intestinale.....754-758, 766-770
Pince micro avec contrepoids.....162, 164
Pince nasale coupante.....893-894, 896, 898
Pince placentaire et pour poste-abortum.....840
Pince porte-fil.....787
Pince pour anastomose rectale.....770-773
Pince pour anastomoses intestinale.....760, 762
Pince pour biopsie.....826-830
Pince pour calculs biliaires.....782-783
Pince pour carotide.....593, 599
Pince pour corps étrangers.....794, 872, 877
Pince pour déchets.....974
Pince pour DIU.....830
Pince pour éponges.....235-237
Pince pour Face-lift.....185, 747
Pince pour fermer et porter les clamps.....762
Pince pour fermer les clamps.....760
Pince pour guide de suture.....706
Pince pour hypophyse.....731-732
Pince pour instruments stérilisés.....956
Pince pour introduction.....858
Pince pour introduire les sondes.....386
Pince pour la cloison nasale.....891, 899, 924
Pince pour le col de l'utérus.....817-820
Pince pour le foie.....626
Pince pour le nez.....870
Pince pour le péritoine.....224-225
Pince pour le redressement de la cloison nasale.....924
Pince pour le rein et pancréas.....627
Pince pour les calculs du bassinet.....780
Pince pour les voies biliaires.....213, 216
Pince pour l'os marteau.....857
Pince pour pénis.....795
Pince pour plâtre.....456
Pince pour polypes auriculaires.....872-875
Pince pour polypes laryngiens.....942
Pince pour poser.....612
Pince pour poser les agrafes.....685
Pince pour poser les clips vasculaires.....172
Pince pour poser micro-clips.....175
Pince pour rompre plâtre.....457
Pince pour saisir intestins et tissus.....750-754
Pince pour saisir la peau.....925
Pince pour saisir les capsules.....786-787
Pince pour saisir les trompes.....159
Pince pour saisir organes.....183-184, 765
Pince pour sondes.....604-605
Pince pour tunnelisation.....234
Pince pour Vena Cava.....625
Pince presse-tubes.....228-229
Pince saisir.....704
Pince Sinus.....233
Pince stomacales et intestinales jumelées.....763-764
Pince tangentielle.....214
Pince utérine pour hémostase.....840
Pince vasculaire pédiatrique.....643-646, 649, 657, 673-676
Pince vasculaire pour nouveaux nés.....675, 677
Pince vasculaire universelle.....596, 618, 635-637, 639-642, 647-648, 650-654, 659-664
Pince vasculaires.....203, 627
Pince-clamps à anastomose.....615, 631-632, 642, 657-658, 660, 662, 664
Pince-clamps à bronches.....587-588, 630
Pince-clamps à poumons.....590
Pince-clamps iliaque.....658
Pince-clamps pour anévrisme.....634
Pince-clamps pour anévrisme de l'aorte.....619-620
Pince-clamps pour aorte.....595, 601-602, 606-609, 621, 624-625, 633, 655
Pince-clamps pour carotide.....659
Pince-clamps pour coarctation.....613-614
Pince-clamps pour occlusion tangentielle.....628
Pince-clamps pour pédicules rénaux.....214-215
Pince-clamps vasculaire périphérique.....597, 600, 603, 616-617
Pince-gouge à cartilage.....916
Pince-gouge pour la cloison nasale.....899-900
Pincés à cartilage.....525-526
Pincés à envies.....951
Pincés à réduction.....526, 528
Pincés coupantes à os.....545-549
Pincés pour amygdales.....935, 937
Pincés pour appliquer et enlever les clips.....685
Pincés pour biopsie rectale.....777
Pincés pour couper ongles.....954, 951
Pincés pour entrelacer les tendons.....524
Pincés pour laminectomie.....724-731
Pincés pour passer les tendons.....523
Pincés pour saisir les tendons.....523, 524
Pincés-clamps pour hémorroïdes.....777
Pincés-gouges.....536-544
Pincette pour saisir et casser les lames de rasoir.....4
Pincette pour saisir et casser les lames de rasoir.....4
Piper, Forceps obstétrique.....839
Pistolet-laveur à jet d'eau.....968
Pittsburgh, Pince pour le foie.....626
Plaque de protection.....882
Plaque de silicone.....959
Plaque pour tendre la peau.....17
Plaques de rechange.....486-488
Plateau universel.....963
Plester, Couteau lobaire.....859
Plester, Ecarteur autostatique.....309
Plester, Tube d'aspiration.....378
Plume.....322
Poids.....869
Poids pour spéculum vaginal.....808-809
Pointe boutonnée.....882
Pointe conique.....882
Pointe de rechange.....683
Pointe de succion.....362, 367, 373
Pointe en plastique.....350
Pointe fileté.....882
Poire en caoutchouc.....880, 881
Poire en caoutchouc avec valve.....880
Politzer, Aiguille pour le tympan.....878
Politzer, Embout conique de raccordement.....881
Politzer, Furunculotome.....878
Politzer, Insufflateur d'air.....881
Politzer, Olive auriculaire.....881
Politzer, Olive nasale.....881
Politzer, Poire en caoutchouc.....881
Polloson, Ecarteur.....283, 284
Poole, Tube d'aspiration.....368
Poppen, Tube d'aspiration.....362
Porte-aiguilles.....408, 411-420, 422-434, 436, 446-447
Porte-boucles.....870
Porte-clamps.....761
Porte-coton.....352
Porte-ligature.....443, 671
Porte-tampon.....934
Potts, Micro-Ciseaux.....114
Potts, Pince vasculaire universelle.....635
Potts, Pince-clamps à anastomose.....615
Potts, Pince-clamps pour coarctation.....613-614
Potts-De Martell-Highmed, Ciseaux à dissection.....123
Potts-Smith, Ciseaux vasculaires.....83
Potts-Smith, Pince à dissection.....142, 145
Potts-Smith, Pince à dissection à griffes.....154
Pousse-fil.....443, 705
Pratt, Pince hémostatique.....184
Pratt, Spéculum rectal.....774
Price-Thomas, Pince-clamps à bronches.....587
Protecteur facial.....952
Providence-Hospital, Pince hémostatique.....188
Putti, Râpe pour os.....482
Quattro, Pince pour plâtre.....456
Quervain, Elévateur.....513
Quire, Pince pour corps étrangers.....872
Raccord.....380
Raccord pour tubes.....380
Ragnell, Ciseaux à dissection.....135
Ragnell-Davis, Crochet.....245
Ralk, Pince à échardes.....170
Rampley, Pince pour éponges.....237
Randall, Pince pour les calculs du bassinet.....780
Raney, Agrafes pour cuir chevelu.....685
Raney, Pincés pour appliquer et enlever les clips.....685
Râpe nasale.....917-920
Râpe pour antré.....917
Râpe pour la glabelle.....918
Râpe pour os.....482
Rapprocheur des côtes.....584
Rasoir.....16
Raspatoir pour palais.....907, 932
Rasse, Ecarteur à os.....240
Rasse, Micro Crochet.....240
Recamier, Curette utérine.....832
Récipient en métal.....964
Record-Arkansas, Pierre à aiguiser.....16
Redon, Aiguille d'introduction.....374-375
Rees, Ciseaux pour Face-lift.....131
Reiner, Couteau pour plâtre.....455
Repose-pied.....868
Resano, Pince à dissection à griffes.....159
Resano, Pince pour anastomose rectale.....773
Ressort de rétention.....882
Retracteur pour amputation.....535
Reverdin, Aiguilles de Reverdin.....435
Reynolds, Ciseaux à dissection.....77-78
Reynolds, Ciseaux chirurgicaux.....78
Ricard, Ecarteur abdominal.....327
Ricard, Ecarteur, seul.....327
Ricard, Valve centrale.....327
Richardson, Ecarteur.....268
Richardson-Eastman, Ecarteur.....267
Richter, Pince à poser les agrafes.....444
Richter, Pincés pour laminectomie.....731
Ritter-Halle, Dilatateur pour le sinus frontal.....926
Robb, Dissecteur vasculaire.....670
Roberts, Pince à disséquer et à ligatures.....202
Robinet.....380
Robinet à trois voies.....380
Rochester-Carmalt, Pince hémostatique.....192
Roeder, Pince à champs.....227
Roger, Elévateur pour le périoste.....910
Rogers, Pince à hystérectomie.....221
Rongeur pour aorte.....557
Rose, Ecarteur pour trachéotomie.....741
Rosen, Couteau circulaire.....859
Rosen, Micro Aiguille auriculaire.....860
Rosen, Micro Rugine-Raspatoire auriculaire.....862
Rosenberg, Embout interchangeable.....939
Ross, Ecarteur pour aorta.....281-282
Roux, Ecarteur.....294
Roux-Baby, Ecarteur.....295
Roux-Mini, Ecarteur.....295
Rubin, Capuchon protecteur.....900
Rubin, Ostéotome.....913
Rubin, Pince-gouge pour la cloison nasale.....900
Rudd, Cône de charge.....776
Rudd, Ligateur pour hémorroïdes.....776
Rugine pour le périoste costal.....507
Rugine pour les lupus.....744
Rugine-raspatoire.....508
Rugine-raspatoire.....498-506, 508
Rugine-raspatoire à succion.....926
Rugine-raspatoire auriculaire.....879
Rumel, Pince à disséquer et à ligatures.....208
Rumel-Belmont, Tourniquet.....671
Ruskin, Pincés-gouges.....540
Ruskin-Liston, Pincés coupantes à os.....547

Russ. Modell, Pince à dissection à griffes157
Rydel-Seiffert, Diapason869
Ryder (Martin), Porte-aiguilles427
Ryder-Vascular, Porte-aiguilles428

S
Saalfeld, Tire-comédons746
Sachs, Crochet pour dure-mère696-697
Sachs, Dissecteur à dure-mère687
Sachse, Calibre794
Sachse, Méatotome794
Salenius, Bistouris à ménisque520
Salpingographe835
Salyer, Ciseaux à dissection72, 119
Salyer, Crochet pour palais932
Salyer, Dissecteur pour palais932
Salyer, Elévateur pour palais932
Samii, Couteau à tumeurs704
Samii, Microcouteau vasculaire705
Samii, Pince saisir702
Sänger, Pince placentaire et pour
 poste-abortum840
Santulli, Clamps Bulldog592
Sanvenero, Ciseaux chirurgicaux72
Sarot, Pince à disséquer et à ligatures202
Sarot, Porte-aiguilles425
Satinsky, Ciseaux vasculaires80
Satinsky, Pince vasculaires627
Satinsky, Pince-clamps pour occlusion
 tangentielle628
Sauerbruch, Boîte pour aiguilles957
Sauerbruch, Costotome555
Sauerbruch, Ecarteur277, 280
Sauerbruch, Pince pour déchets974
Sauerbruch, Pincettes-gouges544
Scalp-Contour, Ecarteur autostatique301
Schädel, Pince à champs226
Schamberg, Tire-comédons746
Schede, Curette tranchante491
Scheibe, Pince pour saisir organes765
Scheinmann, Embout interchangeable938
Scherbak, Manche pour
 spéculum vaginal807, 808
Scherbak, Poids pour spéculum vaginal808
Scherbak, Spéculum vaginal808
Scherbak, Valve vaginale, seule807
Schink, Dermatome17
Schink, Lame de rechange17
Schink, Plaque pour tendre la peau17
Schmeden, Pince nasale coupante898
Schmid, Canule pour irrigation vasculaire379
Schmieden, Aiguilles à ligatures436
Schmieden, Sondes conductrices442
Schmieden-Dick, Aiguilles à ligatures436
Schmieden-Payr, Sondes conductrices442
Schmieden-Taylor, Ciseaux pour la dure-mère90
Schneider, Rugine-raspatoire501
Schmidt, Pince à disséquer et à ligatures192
Schmidt, Pincettes pour amygdales935
Schröder, Pince pour le col de l'utérus817-818
Schubert, Pince pour biopsie826-827
Schuhmacher, Ciseaux pour
 le cordon ombilical98
Schuknecht, Synéchiotome859
Schultze, Manomètre pour salpingographe835
Schultze, Salpingographe835
Schumacher, Embout interchangeable939
Schumacher, Embout, seul830
Schumacher, Pince pour biopsie829-830
Scie du fil métallique682
Scie nasale915
Scie oscillante458
Scoville, Curette tranchante493
Scoville, Ecarteur pour laminectomie340
Scoville, Valve341
Scoville, Valve à griffes341
Scoville-Haverfield, Ecarteur pour
 laminectomie340
Scudder, Pince intestinale770
Seau pour déchets974
Sebileau, Elévateur513
Sedillot, Rugine-raspatoire501, 504
Segond, Evideur de fibromes822
Seiffert, Embout interchangeable938
Sellheim, Levier obstétrique840
Sellors, Rapprocheur des côtes584
Semb, Davier porte-os529
Semb, Pince-clamps à bronches588
Semb, Pincettes coupantes à os549
Semb, Pincettes-gouges540
Semb, Rugine-raspatoire508
Semken, Pince à dissection141
Semken, Pince à dissection à griffes143, 152
Semm, Spéculum vaginal799
Senn-Green, Crochet245
Senn-Miller, Crochet245
Seringue381, 882
Seringue à trois anneaux382
Seringue auriculaire882-883
Seringue pour insuline382
Seringue pour plaies et vessie384
Seringue pour tuberculine383
Serre-noeuds870, 888, 936
Serre-noeuds pour amygdales936
Serrure pour clamps intestinales762
Set "Suture petite"446
Sewall, Rugine-raspatoire501
Shaaf, Pince à échardes168
Shambaugh, Micro Aiguille auriculaire862
Shapleigh, Curette auriculaire876
Shea Vein Graff, Ciseaux à dissection75
Shea, Crochet à exploration862
Silver, Ciseau-burin nasal914
Silver, Dermatome17
Simon, Crochet pour fistules824
Simon, Curette tranchante493
Simon, Curette utérine831
Simon, Ecarteur274
Simpson, Forceps obstétrique838
Sims, Ciseaux à gynécologie40-41
Sims, Curette utérine832
Sims, Hystéromètre816
Sims, Spéculum rectal774
Sims, Spéculum vaginal800
Sims-Aquila, Ciseaux utérins41
Sims-Siebold, Ciseaux à gynécologie45
Sims-TCC-BlackLine, Ciseaux utérins41
Singley-Tuttle, Pince à dissection à griffes158
Skene, Pince pour le col de l'utérus818
Smillie, Bistouris à ménisque520
Smith-Petersen, Gouges478
Smith-Petersen, Ostéotome477
Smithwick, Crochet à nerfs695
Snyder-O.S.U, Gouge464
Socle868
Somer, Pince hystérolabe823
Sonde845
Sonde auriculaire346
Sonde auriculaire870, 888
Sonde boutonée346, 708
Sonde cannelée347
Sonde conductrice pour tendons522
Sonde feuille de myrte346
Sonde pour fistule347
Sondes conductrices441
Sondes conductrices440-443
Sondes métalliques, pour femmes791
Soupape882
Spatule à goitre742
Spatule à laryngoscopie387-391
Spatule à laryngoscopie
 (lumière froide)392-393, 395-397
Spatule abdominale293, 344
Spatule pour fasciotomie669
Spatule pour la tunique interne670
Spatule pulmonaire586
Spatules694
Spatules cérébrales690
Spécula auriculaires (jeu)864-865
Spéculum auriculaire864-865
Spéculum hyphoph733
Spéculum nasal884-887
Spéculum vaginal774
Spéculum rectal798-810
Spencer, Ciseaux à ligatures119-120
Spencer-Wells, Pince hémostatique182
Sphinctéroscope776
Spratt, Curette tranchante492
St. Barts, Pince éthmoïdale895
St. Marks, Ecarteur pour pelvis292-293
Stacke, Sonde auriculaire346
Stella-S, Ciseaux pour Face-lift747
Stellbrink, Pincettes-gouges536
Stevens, Ciseaux à néotomie108-109
Stevens, Ciseaux chirurgicaux108-109
Stieglitz, Pince à échardes170
Stille, Ciseau-burin468
Stille, Gouge469
Stille, Ostéotome468-469
Stille, Pince à dissection139
Stille, Pince à dissection à griffes151
Stille, Pincettes-gouges540
Stille-Barraya, Pince à dissection à griffes157
Stille-Liston, Pincettes coupantes à os547-548
Stille-Luer, Pincettes-gouges543
Stille-Martin, Ciseaux pour plâtre453
Stille-Ruskin, Pincettes-gouges541
Stockmann, Pince pour pénis795
Stone-Watt, Pince pour anastomoses
 intestinale762
Stone-Watt, Pince pour fermer et porter
 les clamps762
Stone-Watt, Serrure pour clamps
 intestinales762
Strandell-Stille, Crochet248
Stratte, Porte-aiguilles416, 429-430
Strauss, Pince pour pénis795
Stripper à anneau351
Strully, Ciseaux pour neurochirurgie90
Strümpel, Pince pour polypes auriculaires873
Struycken, Pince nasale coupante896
Subramanian, Pince-clamps pour aorte672
Subramanian-Miniature, Pince-clamps
 pour aorte672
Support avec tige ronde691-692
Support conducteur pour ostéotomes916
Support d'optique342
Support lumière froide775
Support pour boîtes de Petri956
Support pour spatules690-692
Support pour spécula auriculaires865
Synéchiotome859
Système Bras Martin342
Système d'ecarteurs343

T
Tabb, Couteau pour muqueuse859
Takahashi, Pince éthmoïdale892
Tamis pour spéculum vaginal810
Taylor, Ecarteurs spinaux519
Taylor, Pince à dissection141
Taylor, Pince à dissection à griffes153
Taylor, Valve341
TCC-BlackLine,
 Ciseaux à hystérectomie132-133
Teale, Pince pour le col de l'utérus818
Tête de accouplement691-693
Thoms-Allis, Pince pour saisir intestins
 et tissus751
Thoms-Gaylor, Pince pour biopsie827
Thorek, Ciseaux à dissection63
Tieck-Halle, Spéculum nasal885
Tige pour tunnéliser668
Tire-comédons746
Toennis, Ciseaux à dissection91
Toennis, Dissecteur à dure-mère686
Toennis, Porte-aiguilles418, 433
Toennis-Adson, Ciseaux à dissection91, 129
Tohoku, Pince à champs227, 446-447

Tönnis-Adson TCC-BlackLine,
Ciseaux à dissection129
Tönnis-Adson-Aquila, Ciseaux à dissection.....129
Tords-fil.....443
Tournevis.....668
Tourniquet671
Toynbee, Spécula auriculaires, jeu864
Tracteur pour myomes.....822
Trelat, Rugine-raspatoire500
Trelat, Spéculum vaginal.....799
Tréfans cutanés.....745
Trocart358
Trölsch (Wilde), Fil en acier.....871
Trölsch, Pince à pansements890
Trousse à varices348, 350
Trousse pour laryngoscopes391
Trousseau, Dilatateur pour la trachéotomie740
Trotman-Chris, Pincette pour saisir
et casser les lames de rasoir.....4
Tubbs, Dilatateur pour aorte665
Tube d'aspiration.....348, 360-363,
Tube d'aspiration.....348, 359-365,
.....367-369, 372-373, 377-378
Tube de connection795, 882
Tube laryngien937, 938, 939
Tube rallonge830
Tuffier, Ecarteur de côtes563
Tuffier, Pince hémostatique.....183
Tuohy, Aiguille pour ponction lombaire377
Turnbull, Pincettes pour couper ongles.....950
Tyding, Serre-noeuds pour amygdales.....936

U

Ulrich, Davier porte-os531
Ulrich, Pince à tampons.....232
Universal, Ciseaux coupe-fil121
Universal, Ciseaux pour pansements452
Universal, Lance-poudre880
Universal, Trocart358
Unna, Tire-comédons.....746
Unna-Vidal, Tire-comédons.....746
Urétrotome792

V

Valleix, Hystéromètre816
Valve.....315-316, 337-339, 341
Valve à griffes341
Valve centrale312, 322, 325-327,
.....330-336, 775, 789
Valve en fil335
Valve laterale324-329, 558, 565-571,
.....573-574, 577-582
Valve vaginale, seule.....807
Van Buren, Bougie urétrale.....790
Van Doren, Pince pour biopsie.....828
Vannas, Micro-Ciseaux698
Varady, Dissecteur pour phlébite349
Varady, Extracteur pour phlébite micro349
Varady, Extracteur pour phlébite mini349
Varady, Micro dissecteur349
Varady, Olive348
Varady, Trousse à varices348
Veidenheimer, Pince pour
anastomose rectale.....772
Verbrugge, Davier porte-os.....534, 535
Verhoeven, Tube d'aspiration377
Verre de rechange.....949
Verres, Canule pour insufflation378
Vickers Low-Profile, Ecarteur autostatique322
Vickers Low-Profile, Valve centrale322
Vickers, Ecarteur322
Vidal, Rugine pour les lupus.....744
Virchow, Burin pour le crâne.....464
Virchow, Couteau à cerveau3
Vis521
Vis de rechange.....470
Vis moletée.....869
Volkmann, Curette double496

Volkmann, Curette tranchante.....490, 491
Volkmann, Ecarteur250-252
Vollmar, Canule pour irrigation vasculaire.....378
Vollmar, Stripper à anneau351

W

Wachenfeldt, Pince à poser les agrafes444
Wagener, Crochet auriculaire878
Wagner, Ciseaux chirurgicaux100
Wagner, Pincettes pour laminectomie.....730
Waldmann, Ciseaux à épisiotomie97
Walter, Gouge913
Walter, Ostéotome913
Wangensteen, Pince à dissection146
Wangensteen, Porte-aiguilles.....416, 428
Wassmund, Ecarteur256
Watson-Cheyne, Dissecteur double.....513
Watson-Williams, Pince éthmoïdale.....893
Waugh, Pince à dissection.....140
Waugh, Pince à dissection à griffes152
Weber, Pince-clamps pour aorte.....624
Weber-Loch, Curette / crochet auriculaire877
Webster, Porte-aiguilles412, 419, 423-424
Weil, Pince nasale coupante893
Weil-Blakesley, Pince éthmoïdale.....894-895
Weil-Blakesley, Pince nasale coupante894
Weissbarth, Spéculum vaginal810
Weissbarth, Tamis pour spéculum vaginal810
Weitlaner, Ecarteur autostatique30, 303,
.....306-307, 446-447
Weitlaner-Baby, Ecarteur autostatique311
Weitlaner-Wullstein, Ecarteur autostatique308
Wertheim, Ciseaux à gynécologie46
Wertheim, Pince à hystérectomie223
Wertheim-Cullen, Pince vaginale.....220
Westcott, Ciseaux à strabisme110
Westmacott, Pince à pansements.....890
White, Pincettes pour amygdales935
Wikstroem, Pince à disséquer et à ligatures...211
Williams, Ecarteur autostatique310
Williams, Pince pour saisir intestins
et tissus752
Williger, Curette double.....497
Williger, Elevateur513
Williger, Maillet.....484, 486
Williger, Rugine-raspatoire.....505
Winter, Pince placentaire
et pour poste-abortum840
Wolff, Curette pour les lupus744
Wolff, Pince pour rompre plâtre457
Wrigley, Forceps obstétrique838
Wullstein, Canules d'aspiration363
Wullstein, Micro Ciseaux auriculaires855
Wullstein, Synéchiotome859
Wullstein, Tube d'aspiration.....363
Wylie, Pince-clamps pour aorte.....601, 625

Y

Yankauer, Manche367
Yankauer, Olive367
Yankauer, Pointe de succion367
Yankauer, Tube d'aspiration366, 367
Yasargil, Ecarteur Galea686
Yasargil, Fourche à tumeurs704
Yasargil, Micro Curette.....708
Yasargil, Micro Dissecteur707
Yasargil, Micro porte-aiguilles701
Yasargil, Micro Rugine-Raspatoire.....706
Yasargil, Micro-Ciseaux699
Yasargil, Micro-Ciseaux à dissection699
Yasargil, Microcouteau vasculaire.....705
Yasargil, Micro-Pince702
Yasargil, Pince à tumeurs.....702
Yasargil, Pince pour guide de suture.....706
Yasargil, Pince pour hypophyse.....731, 732
Yasargil, Pince saisir.....702
Yasargil, Tube d'aspiration.....365
Yasargil-Samii, Pince saisir702

Young, Aiguilles de rechange436
Young, Ecarteur prostatiques785
Young, Porte-aiguilles436

Z

Zanger, Pince-clamps pour aorte.....606
Zaufal, Levier pour corps étrangers.....877
Zaufal-Jansen, Pincettes-gouges.....539
Zeller, Lunettes protectrices952
Zenker, Ecarteur.....265
Zenker, Pince à disséquer et à ligatures.....209
Zielke, Gouge.....467
Zöllner, Pointe de succion362
Zöllner, Spécula auriculaires, jeu865
Zöllner, Spéculum auriculaire.....865
Zöllner, Tube d'aspiration362
Zweifel, Porte-aiguilles.....434

Indice, alfabetico
Italiano

i

A			
Accumulatore induttivo.....	399, 400	Balfour, Mod. USA, Valva di filo.....	335
Adattatore.....	792	Balfour, Valva centrale.....	332, 334-335
Adattatore Luer.....	668	Balfour-Baby, Divaricatore addominale.....	331
Adattatore per cateteri.....	380	Balfour-Standard, Divaricatore addominale.....	334
Adattatore per lavaggio.....	883	Ballenger, Bisturi per il setto nasale.....	906
Adlerkreutz, Pinza per dissezione con denti.....	151	Ballenger, Sgorbia per il setto nasale.....	911
Adson, Divaricatore autostatico.....	304-306, 313-314, 318	Ballenger-Hajek, Elevatore per il setto nasale.....	909
Adson, Elevatore.....	510	Barbara, Micro Ago auricolare.....	860-861
Adson, Pinza per dissezione.....	140, 144	Barbara, Micro Uncino auricolare.....	860
Adson, Pinza per dissezione con denti.....	144, 152	Baron-Schuknecht, Tubo di aspirazione.....	363
Adson, Pinza per preparazione e legature.....	192	Barra trasversale.....	343
Adson, Portaghi.....	413	Barraquer, Micro Portaghi.....	409, 423
Adson, Tubo di aspirazione.....	360	Barraquer, Pinza depilatoria.....	169
Adson, Uncino per dura-madre.....	696	Barraquer-Troutman, Micro Portaghi.....	408
Adson-Baby, Pinza per preparazione e legature.....	201	Base di Bakelit.....	869
Adson-Brown, Pinza per dissezione con denti.....	144, 155	Beacham, Amniotomo.....	817
Ago di ricambio.....	174, 436	Beck, Pinza vascolare universale.....	642, 651
Ago per dissezione.....	402-403	Beckman-Adson, Divaricatore autostatico.....	319
Ago per eparinea.....	376, 379	Beckman-Eaton, Divaricatore autostatico.....	320
Ago per legatura.....	436-440	Beckmann, Coltello per vegetazioni adenoidee.....	926
Ago per timpano.....	878	Beckmann, Divaricatore autostatico.....	317
Alan-Parks, Dilatatore rettale.....	775	Beebe, Forbici per tagliare fili metallici.....	122
Alderdyce, Dissetto doppio.....	513	Beer, Pinza depilatoria.....	169
Alesatore.....	683	Bellucci, Micro Forbici auricolare.....	854
Alexander, Periostotomo.....	508	Bengolea, Pinza emostatica.....	195
Alexander, Pinza per biopsia.....	829	Bennett, Elevatore per ossa.....	518
Alexander, Scalpello.....	467	Benson, Divaricatore pilorico.....	761
Alexander, Sgorbia.....	467	Bergmann, Forbici per gesso.....	451
Allen, Pinza intestinale.....	758	Bergmann, Pinza per tamponi e sponge.....	236
Allenberg-Cobra, Pinza vascolare universale.....	664	Bernhard, Pinza fissateli.....	227
Allis, Pinza per afferare intestino e tessuti.....	750-751	Bethune, Costotomo.....	555
Allis-Adair, Pinza per afferare intestino e tessuti.....	751	Beyer, Pinza osteotomo.....	875
Allis-Baby, Pinza per afferare intestino e tessuti.....	750	Beyer, Pinza-sgorbia.....	539
Allison, Spatola per polmone.....	586	Biemer, Clip vascolare.....	172
Alm, Divaricatore autostatico.....	300	Biemer, Forbici micro per vene.....	116
Amniotomo.....	817	Biemer-Müller, Approssimatore.....	173
Anderson-Adson, Divaricatore autostatico.....	301	Billeau, Ansa auricolare.....	877
Anello di gomma.....	776	Bircher-Ganske, Pinza per cartilagine.....	525
Ansa auricolare.....	877	Bisturi / Enucleatore per tonsille.....	933
Anuscopio.....	774	Bisturi per dissezione.....	2
Appoggiapiedi.....	868	Bisturi per fibromi.....	822
Approssimatore.....	172-174	Bisturi per il cono d'attrazione.....	824
Approssimatore costale.....	584	Bisturi per il setto nasale.....	906
Approssimatore per nervi.....	174	Bisturi per mucosa.....	859, 906
Aquila, Forbici per isterectomia.....	132-133	Bisturi per plastica nasale.....	905
Arruga, Micro Portaghi.....	408	Bisturi per uso unico.....	13-14
Arruga, Portaghi.....	411, 422	Bisturi tumore.....	704
Asch, Pinza per raddizzare il setto nasale.....	924	Blake, Curetta uterina.....	831
Aspiratore.....	882	Blake, Pinza per calcoli biliari.....	782
Aston, Forbici per Face-lift.....	57	Blohmke, Pinza per tonsille.....	935
Aufricht, Divaricatore nasale.....	921, 923	Blount, Divaricatore per il ginocchio.....	519
Aufricht, Raspa per glabella.....	918	Blumenthal, Pinza-sgorbia.....	538
Austin, Dissetto per l'attico.....	862	Böhler, Cesoa per ossa.....	546
Austin, Micro-Pinza per legature.....	167	Böhler, Pinza-sgorbia.....	539
Auward, Specolo vaginale.....	809	Bonney, Pinza per dissezione con denti.....	143, 158
Ayre, Bisturi per il cono d'attrazione.....	824	Borowski, Divaricatore per aorta.....	282
Babcock, Pinza per afferare intestino e tessuti.....	752-753	Bottiglia di ricambio.....	880
		Bottone di ricambio.....	868
		Bowman, Sonda.....	845
		Boys-Allis, Pinza per afferare intestino e tessuti.....	751
B		Bozemann, Pinza per tamponi e sponge.....	235
Baby-Adson, Pinza emostatica.....	185	Bozemann, Portaghi.....	429
Baby-Poole, Tubo di aspirazione.....	368	Bozemann, Torcifero.....	443
Bacinella reniforme.....	965	Braccio di fissaggio.....	343, 692-693
Backhaus, Pinza fissateli.....	226	Braccio flessibile.....	690, 691, 692
Bailey, Approssimatore costale.....	584	Braun, Depressore uterino.....	816
Bailey-Baby, Approssimatore costale.....	584	Braun, Pinza per il collo dell'utero.....	817, 820
Bailey-Gibbon, Approssimatore costale.....	584	Braun-Stadler, Forbici per episiotomia.....	97
Bainbridge, Pinza vascolare universale.....	618	Breisky, Specolo vaginale.....	810
Bakes, Dilatatore per condotti biliari.....	781	Brom, Divaricatore per vene.....	248
Balfour, Divaricatore addominale.....	332-333	Brompton, Pinza con rotelle.....	230
Balfour, Mod. USA, Divaricatore addominale.....	335	Brophy, Pinza per dissezione con denti.....	153
		Brown, Portaghi.....	413
		Brünings, Coltello per tonsille.....	933
		Brünings, Pinza intercambiabile per bronco-esofagoscopia.....	938
		Brünings, Pinza per il setto nasale.....	891
		Brünings, Serrandi per tonsille.....	936
		Brünings, Tubo allunghi.....	830
		Brünings, Tubo laringeo.....	937, 938, 939
		Brunner, Ago per legatura.....	440
		Brunner, Costotomo.....	556
		Brunner, Divaricatore.....	278-279
		Brunner, Pinza per anastomosi retali.....	770
		Brunner, Sonda conduttrice.....	440, 442
		Bruns, Curetta tagliente.....	492-493
		Bruns, Forbici per gesso.....	452, 454
		Buck, Curetta auricolare.....	876
		Buck, Forbici per legature.....	120
		Buck, Pinza per corpi estranei.....	872
		Buckley, Divaricatore autostatico.....	299
		Burford, Divaricatore costale.....	560
		Busch, Forbici ombelicale.....	98
		Bushe, Curetta tagliente.....	495
		Byrd, Tubo di aspirazione.....	373
		C	
		Calibro.....	794
		Calne, Pinze per Vena Cava.....	625
		Calotta protettiva.....	900
		Candeletta dilatatrice.....	790
		Candeletta filiforme.....	791
		Cannula.....	376
		Cannula auricolare.....	880
		Cannula d'aspirazione.....	359, 363, 366-368, 370-371
		Cannula per anestesia trasvaginale.....	376
		Cannula per lavaggio.....	378
		Cannula per insufflazione.....	378
		Cannula per irrigazione vascolare.....	378, 379
		Cannula per la puntura del fegato.....	379
		Cannula per puntura lumbale.....	377
		Cannula per tonsille.....	364, 377
		Cannula per vene.....	376
		Caplan, Pinza per il setto nasale.....	899
		Carpenter, Bisturi / Enucleatore per tonsille.....	933
		Carrucola mobile.....	343
		Caspar, Forchetta di sutura.....	705
		Caspar, Micro Dissetto.....	705
		Caspar, Micro-Forbici.....	700
		Caspar, Pestone metallico.....	483
		Caspar, Pinze per laminectomia.....	724-729
		Caspar, Unicino per nervi e vasi.....	709
		Castañeda, Divaricatore costale.....	561
		Castañeda, Pinza vascolare per neonati.....	677
		Castroviejo, Compasso.....	844
		Castroviejo, Micro Portaghi.....	404-405, 410-411, 422-423
		Castroviejo, Micro-Forbici.....	111
		Castroviejo, Pinza per afferare e rompere le lamette di rasoio.....	4
		Castroviejo-Epker, Compasso.....	844
		Castroviejo-Fino, Micro Portaghi.....	409
		Cerullo, Tubo di aspirazione.....	365
		Cesoa per ossa.....	545-549, 554
		Chaput, Pinza emostatica.....	183
		Cheattle, Pinza per strumenti sterilizzazione.....	956
		Cheron, Pinza per medicature.....	235
		Chiave.....	470
		Chiave per approssimatore.....	174
		Childe, Pinza per i margini della ferita.....	444
		Cilindro di ricambio.....	381-384
		Cinelli, Forbici nasale.....	63
		Cinelli, Osteotomo.....	914
		Cinta frontale sola.....	952
		Citelli, Pinza osteotomo.....	874
		Clamp ombelicale.....	842
		Cleveland, Cesoa per ossa.....	546
		Cleveland, Pinza-sgorbia.....	536
		Clip vascolare.....	172, 179
		Cloward, Divaricatore autostatico.....	315-316
		Cloward, Separatore per vertebre.....	710
		Cloward, Valva.....	315-316
		Coakley, Curetta per antro.....	925
		Cobb, Sgorbia.....	479

Divaricatore per ossa	240	Finsen-Martin, Divaricatore autostatico.....	298	G	
Divaricatore per pelle.....	240-241, 745	Fisch, Micro Dissettore	862	Gallaher, Raspa per seno mascellare	917
Divaricatore per scapola.....	276	Fisher, Coltello per tonsille.....	933	Gambo per tunnelare	668
Divaricatore per sterno.....	563	Fissaggio di ottica	342	Gardner, Scalpello	464
Divaricatore per sternotomia	558	Flebo-dissettore	349	Gellhorn, Pinza per biopsia.....	826
Divaricatore per tiroide e vagina.....	323	Flebo-estrattore.....	349	Gelpei, Divaricatore autostatico	323
Divaricatore per veni.....	248	Fomon, Bisturi per plastica nasale	905	Gemini, Pinza per preparazione e legature	207
Divaricatore prostatico	785	Fomon, Forbici nasale.....	63, 95	Gerald, Pinza atraumatica	148
Divaricatore spinale	519	Fomon, Raspa nasale.....	918, 920	Gerald, Pinza per dissezione.....	142
Divaricatore valve	583	Fomon, Scalpello	913	Gerald, Pinza per dissezione	
Divaricatore vascolare	242	Fomon, Uncino per le pinne nasali.....	921-922	con denti.....	143, 154
Divaricatore vescicale	788-789	Forbici micro per vene	116	Giertz-Stille, Costotomo	555
Divaricatore, solo	327, 337-339, 565-568,	Forbici nasale	63, 95-96	Gigli, Manico con uncino	682
.....	570, 572-574, 579-581	Forbici ombelicale.....	98	Gigli, Sega da filo di ferro	682
Divaricatore pilorico	761	Forbici per arteria coronaria	82, 85-87, 89	Gillies, Pinza per dissezione	
Douglas, Pinza depilatoria.....	169	Forbici per bendaggi.....	450, 452, 454	con denti.....	143, 152
Doyen, Divaricatore	273	Forbici per chirurgia.....	20, 22, 24, 26, 28,	Gillies, Portaghi	417, 432
Doyen, Forbici per ginecologia	44	30-37, 42-43, 73-74, 78,	Gillies, Uncino cutaneo.....	745
Doyen, Martello.....	484	100, 103, 108-109,	Gillies-Mini, Portaghi	432
Doyen, Periototomo costali.....	507	446-447	Gil-Vernet, Divaricatore a forma di sella.....	247
Doyen, Pinza intestinale.....	754, 766	Forbici per dissezione.....	34-39, 47-56,	Giravite	668
Doyen, Sonda cannellata.....	347	58-74, 75-78, 82, 91,	Giunto a sfera	692, 693
Doyen, Specolo vaginale	806, 810	101, 119, 123-124, 126-128,	Glover, Pinza Bulldog.....	592, 612
Doyen, Tiramioni	822	130, 135, 446-447	Glover, Pinza per anastomosi	631
Doyen-Baby, Pinza intestinale.....	755, 766	Forbici per dura madre	90	Glover, Pinza vascolare universale	640
Doyen-Stille, Divaricatore	269	Forbici per enterotomia	118	Gluck, Costotomo	554
Dubost, Divaricatore per il torace	570	Forbici per enucleazione	110	Goelet, Divaricatore	297
Dubost, Divaricatore solo.....	570	Forbici per episiotomia	97	Goldman-Fox, Forbici per gengiva	99
Dubost, Valva laterale	570, 571	Forbici per Face-lift.....	57, 75, 119, 131,	Goldmann-Fox, Forbici per legature.....	99
Dunhill, Pinza emostatica	189	747-748	Goldsmith (Thudichum), Specolo nasale.....	884
Duplay, Pinza per il collo dell'utero	817	Forbici per gengiva	99, 101-102	Good, Forbici per tonsille	93
Durante, Pinza per dissezione con denti	157	Forbici per gesso	451-454	Goodell, Dilatatore uterino.....	811
Duval, Pinza per afferare		Forbici per ginecologia.....	40-41, 44-46	Gorney, Forbici per Face-lift	57, 131, 748
intestino e tessuti.....	753-754	Forbici per il nervo trigemino.....	92	Gosset, Divaricatore addominale	330-331
E		Forbici per il retto	118	Gosset-Baby, Divaricatore addominale	330
Echlin, Pinza-sgorbia	541	Forbici per incisione	33	Graefe, Forbici per iridectomia	104
Eicken-Killian, Cannula per lavaggio	926	Forbici per iridectomia	103-107	Graefe, Micro Divaricatore	240
Eiselsberg, Forbici per legature.....	120	Forbici per isterectomia	132-133	Graffe	445
Elevatore.....	510, 512-513	Forbici per legature	99, 119-120, 124-125	Graham, Uncino per dura-madre.....	696
Elevatore per il periosto	910, 911	Forbici per nervi	56	Graig, Pinza per il setto nasale	891
Elevatore per il setto nasale.....	907-910	Forbici per neurchirurgia.....	90, 92	Grant, Pinza per aorta.....	607
Elevatore per ossa	514-519	Forbici per strabismo	110	Grave, Specolo vaginale	799
Elevatore per palato	932	Forbici per tagliare fili metallico	121-122, 135	Green-Armytage, Pinza emostatiche	
Elevatore per tonsille.....	933-934	Forbici per tenotomia	108-109	per tagli cesarei	840
Emmett, Uncino per fistole	824	Forbici per tonsille	93-94	Greene, Curetta uterina	834
Endospecoli	811	Forbici per unghie	950	Gregory, Forbici Face-lift	747
Endospecolo	811	Forbici vascolare.....	80-84, 88-90, 107, 134	Gregory, Micro Portaghi	420
Esmarch, Coltello per gesso.....	455	Forchetta da sutura	443, 705	Gregory, Pinza carotis	593
Esmarch, Forbici per gesso.....	451	forchetta tumore	704	Gregory, Pinza profonda	598
Eves, Serranodi per tonsille	936	Forcipe ostetrica	838-839	Gregory, soft, Pinza carotis	593
F		Foregger, Set per laringoscopia	390	Groningen, Uncino per nervi	695
Fahlbusch, Micro-Forbici	700	Foregger, Set per laringoscopia		Gross, Cucchiaino/uncino auricolare.....	877
Farabeuf, Divaricatore	295	(luce fredda).....	394	Gross-Maier, Pinza per	
Farabeuf, Periototomo	502	Foregger, Spatola per laringoscopia	390, 391	medicature	234, 446-447
Farabeuf, Tenaglia per ossa	530	Foregger, Spatola per laringoscopia		Grünwald (Jansen), Pinza per medicature	890
Farabeuf-Collin, Periototomo.....	502	(luce fredda).....	395	Grünwald, Pera di gomma	880
Farell, Portacottone	352	Förster, Pinza per tamponi e sponge	236-237	Grünwald, Pinza auricolare.....	871
Farrior, Specolo auricolare.....	865	Foster-Gillies, Portaghi	432	Grünwald, Pinza per medicature	890
Faulkner, Curetta doppia.....	925	Fox, Curetta per lupus	744	Guarnizione ad anello	880
Faure, Pinza per biopsia.....	826	Fraenkel, Pinza intercambiabile		Guarnizione di gomma	882
Faure, Pinza per peritoneo	225	per bronco-esofagoscopia.....	938	Guedel-Negus, Set per laringoscopia	388
Favaloro, Forbici vascolare	88, 90	Frazier, Tubo di aspirazione.....	360-361	Guedel-Negus, Spatola per laringoscopia	388
Fehlhand, Pinza per anastomosi rettali.....	772	Frazier, Uncino per dura-madre.....	697	Guilen, Raspatorio con aspiratore.....	926
Feilchenfeld, Pinza per scheggie.....	167	Freeman, Forbici Face-lift	748	Gunnar-Hey, Pinza con rotelle.....	230
Fergusson, Cannula d' aspirazione	361	Freeman-Kaye, Forbici Face-lift	748	Guthrie, Divaricatore per pelle	241
Fergusson, Tenaglia per ossa	527	Freer, Bisturi per il setto nasale	906	Guttman, Specolo vaginale	799
Ferris-Smith-Kerrison, Pinza tagliente		Freer, Bisturi per mucosa	906	Guyon, Candeletta dilatatrice.....	790
per seno sfenoidale	902	Freer, Elevatore per il periosto	911	Guyon, Pinza per peduncoli renali.....	214-215
Filiform, Candeletta filiforme.....	791	Freer, Elevatore per il setto nasale	907-908		
Filo in acciaio	870, 888, 936	Freer, Sgorbia per il setto nasale.....	911		
Finochietto (modif.), Divaricatore costale.....	561	Freer, Uncino per mucosa	922		
Finochietto, Baby, Divaricatore costale	564	French, Diapason	866	H	
Finochietto, Divaricatore costale	560, 564	Friedmann, Pinza-sgorbia.....	536	Haberer, Spatola addominale.....	344
Finochietto, Infant, Divaricatore costale.....	559	Fritsch, Divaricatore	272	Hach, Spatola per fasciotomia	669
Finochietto, Pinza per preparazione		Frosch, Tenaglia per ossa	527	Haight, Divaricatore costale.....	562
e legature	213	Frykholm, Pinza-sgorbia	542	Hajek, Pinza tagliente per seno sfenoidale	901
Finochietto, Portaghi	415, 427	Fuller, Pinza per introduzione	858	Hajek-Kofler, Pinza tagliente	
Finsen, Divaricatore autostatico	298	Fune di trazione	350	per seno sfenoidale	901

Halsted-Mosquito, Pinza emostatica.....	186-187, 446-447
Hank, Dilatatore uterino.....	815
Harken, Pinza ventricolare.....	629
Harrington, Divaricatore.....	285
Hartmann, Diapason.....	866-868
Hartmann, Divaricatore autostatico.....	311
Hartmann, Pinza emostatica.....	186
Hartmann, Pinza per polipi auricolari.....	872-873
Hartmann, Pinza per polipi nasali.....	890
Hartmann, Pinza per tonsille.....	937
Hartmann, Pinza tagliente per il naso.....	898
Hartmann, Pinza-sgorbia.....	537
Hartmann, Sonda auricolare.....	870
Hartmann, Specolo auricolare.....	864
Hartmann, Uncino auricolare.....	877
Hartmann-Halle, Specolo nasale.....	884
Hartmann-Herzfeld, Pinza per polipi auricolari.....	873
Hartmann-Hoffman, Pinza per polipi auricolari.....	873
Hartmann-Wullstein, Pinza per polipi auricolari.....	873
Hayes, Pinza per anastomosi rettali.....	771
Heaney, Pinza per isterectomia.....	219
Heaney, Portaghi.....	414, 426
Hegar, Dilatatore uterino.....	812-814
Hegar, Dilatatore uterino, serie.....	812
Hegar, Portaghi.....	429
Hegar-Baumgartner, Portaghi.....	413, 424
Hegar-Vascular, Portaghi.....	429
Hegenbarth, Pinza per applicare le graffe.....	444
Heifetz, Pinze afferarre.....	702
Heifetz, Spatul.....	694
Heiming, Pinza per calcoli renali.....	780
Heiss, Pinza per preparazione e legature.....	201
Henckel-Tilley, Pinze nasale.....	870
Henke, Elevatore per tonsille.....	934
Henley, Divaricatore autostatico.....	312
Henley, Valva centrale.....	312
Henly, Pinza per cateteri.....	604
Hennig, Pinza per gesso.....	456
Hepp-Scheidel, Micro Portaghi.....	419
Hepp-Scheidel, Pinza per afferrare tubi.....	159
Heymann, Forbici nasale.....	96
Heywood-Smith, Pinza per polipi uterini.....	821
Hibbs, Osteotomo.....	480-481
Hibbs, Scalpello.....	480
Hibbs, Sgorbia.....	481
Hohenfellner, Forbici per dissezione.....	61
Hohman, mini, Elevatore per ossa.....	514
Hohmann, Elevatore per ossa.....	515-517
Hoke, Osteotomo.....	480
Hopkins, Coltello per gesso.....	455
Hösel, Divaricatore.....	270
Hösel, Micro cucchiaino.....	863
House, Micro Sonda per misurare.....	863
House, Tubo di aspirazione.....	369
House-Dieter, Pinza per testa del martelletto.....	857
Howarth, Elevatore per il setto nasale.....	909
Huber, Manico universale.....	830
Humby, Dermatomo.....	17
Humby, Lama di ricambio.....	17
Hunt, Pinze afferarre.....	703
Hunter, Pinza per scheggie.....	168
Hurd, Disettore / Retrattore per tonsille.....	933
Husfeldt, Pinza vascolare periferale.....	603
I	
Inge, Separatore per osso.....	710
Inge, Separatore per vertebre.....	710-711
Insuffiatore d'aria.....	881
Insuffiatore polvere.....	880
Introduttore per sega da filo di ferro.....	682
Iowa, Pinza per il collo dell'utero.....	819
Israel, Divaricatore.....	257
Isterometro.....	816
Iterson, Uncino tracheale.....	741
Ives-Fansler, Anuscopio.....	774

J	
JABOMA, Micro Portaghi.....	419
JABOMA, Micro-Forbici.....	117
JABOMA, Pinza per dissezione.....	147
JABOMA, Pinza per dissezione con denti.....	147
Jackson, Specolo vaginale.....	800
Jackson, Uncino tracheale.....	741
Jacobs, Pinza per il collo dell'utero.....	819
Jacobson, Curetta tagliente.....	496
Jacobson, Micro Portaghi.....	701
Jacobson, Micro-bisturi vascolare.....	705
Jacobson, Micro-Forbici.....	114, 698
Jacobson, Sonda a bottone.....	708
Janet, Siringa per vescica e ferite.....	384
Jansen, Curetta auricolare.....	877
Jansen, Divaricatore autostatico.....	300
Jansen, Periostotomo.....	500
Jansen, Pinza auricolare.....	871
Jansen, Pinza-sgorbia.....	537
Javid, Pinza carotis.....	599
Jeweler mod., Micro pinze per dilatazione.....	162
Jeweler mod., Micro-Pinza.....	162
Johns-Hopkins, Pinza Bulldog.....	177
Johnson, Portaghi.....	416
Joll, Divaricatore per tiroide e vagina.....	323
Jones, Pinza fissateli.....	226
Jones-Martin, Pinza fissateli.....	226
Joseph, Bisturi per plastica nasale.....	905
Joseph, Elevatore per il periostio.....	910
Joseph, Elevatore per il setto nasale.....	907
Joseph, Forbici per chirurgia.....	73,74
Joseph, Forbici per dissezione.....	73-74
Joseph, Lima per ossa.....	917
Joseph, Segna nasale.....	915
Joseph, Uncino per mucosa.....	921-922
Joseph-Masing, Elevatore per il periostio.....	910
Jud-Allis, Pinza per afferrare intestino e tessuti.....	751
Judd-Masson, Divaricatore vescicale.....	788
Jurasz, Pinza per polipi laringei.....	942
K	
Kabierske, Bottiglia di ricambio.....	880
Kabierske, Cannula auricolare.....	880
Kabierske, Insuffiatore polvere.....	880
Kabierske, Pallone in gomma con valva.....	880
Kader, Spatola addominale.....	293
Kahre-Williger, Periostotomo.....	505
Kallmorgen, Specolo vaginale.....	805
Kallmorgen, Valva vaginale.....	805
Kalt, Micro Portaghi.....	408
Katsch, Tiracomodoni.....	746
Kaye, Forbici per Face-lift.....	57, 119, 747
Kaye, Manico per bisturi.....	9
Kaye, Uncino face-lift.....	745
Kaye-Millard, Divaricatore.....	248
Kelly, Divaricatore.....	268, 291
Kelly, Forbici per chirurgia.....	42-43
Kelly, Pinza emostatica.....	189
Kelly, Pinza per polipi uterini.....	821
Kelly, Pinza per preparazione e legature.....	217
Kelly, Sfincteroscopio.....	776
Kelly-Rankin, Pinza emostatica.....	190
Kern, Tenaglia per ossa.....	529
Kerrison, Pinza tagliente per laminectomia.....	712-723
Kerrison, Pinza tagliente per seno mascellare.....	904
Kevorkian, Curetta per biopsia.....	825
Kevorkian, Pinza per biopsia.....	829
Key, Periostotomo.....	503
Keyes, Trefina cutanea.....	745
Kielland, Forcipe obstetrica.....	839
Kielland-Luikart, Forcipe obstetrica.....	839
Killian, Elevatore per il setto nasale.....	909
Killian, Sgorbia per il setto nasale.....	911

Killian, Specolo nasale.....	885
Killian-Claus, Sgorbia per il setto nasale.....	911
Kilner, Forbici per dissezione.....	76
Kilner, Portaghi.....	423
Kilner, Uncino cutaneo.....	745
Kilner, Uncino per le pinne nasali.....	922
Kirschner, Divaricatore addominale.....	337-338
Kirschner, Sonda conduttrice.....	441-442
Kirschner, Telaio, solo.....	337-339
Kirschner, Valva.....	337-339
Klapp, Divaricatore.....	249
KLING-EX, Distributore Lama.....	10
Knight, Pinza per il setto nasale.....	891
Knowles, Forbici per bendaggi.....	450
Knutson, Strumento per uretrografia.....	793
Knutson-Koch, Cono.....	793
Kocher (Ochsner), Pinza emostatica.....	198-199
Kocher, Divaricatore.....	253, 262, 266, 273
Kocher, Pinza emostatica.....	194, 446-447
Kocher, Pinza intestinale.....	757-758, 768-769
Kocher, Sonda per gozzo.....	742
Kocher-Langenbeck, Divaricatore.....	263-264
Kocher-Nippon, Pinza emostatica.....	194
Koenig, Periostotomo.....	500
Kogan, Endospecolo.....	811
König, Diapason.....	869
König, Sonda conduttrice.....	442
Koos, Micro-bisturi vascolare.....	705
Körte, Divaricatore.....	256
Krause, Pinza intercambiabile per bronco-esofagoscopia.....	939
Krause, Serranodi.....	870, 888
Krause-Voss, Serranodi.....	870, 888
Krayenbühl, Uncino per nervi e vasi.....	709
Krenkel, Raspatore per palato.....	907
Kressner, Pinza per il setto nasale.....	924
Kristeller, Specolo vaginale.....	801-804
Kristeller, Valva vaginale.....	801-804
Kronecker, Ago per legatura.....	437
L	
La Grange, Forbici per gengiva.....	101
Laborde, Dilatatore per tracheotomia.....	740
Laccio.....	936
Lahey, Divaricatore.....	261
Lahey, Pinza per gozzo.....	742
Lahey, Pinza per vie biliari.....	213
Lama di ricambio.....	17
Lama di ricambio.....	453, 792
Lama intercambiabile.....	470
Lama intercambiabile, concava.....	470
Lama per bisturi (non sterili).....	10-11
Lama per osteotomia, intercambiabile.....	470
Lama per sega.....	10, 458
Lamatta da rasoio.....	4
Lambert-Kay, Pinza per anastomosi.....	632
Lambert-Kay, Pinza vascolare universale.....	654
Lambotte, Osteotomo.....	475-476
Lambotte, Periostotomo.....	508
Lambotte-Mini, Osteotomo.....	474
Lampadina di ricambio.....	391, 398
Landolt, Periostotomo.....	500
Landolt, Pinza per afferrare tumori.....	732
Landolt, Tubo di aspirazione.....	365
Lane, Pinza fissateli.....	228
Lane, Pinza gastrointestinali gemelle.....	763-764
Lane, Tenaglia per ossa.....	533
Lange, Pinza intercambiabile per bronco-esofagoscopia.....	938
Lange, Uncino per le pinne nasali.....	921
Lange-Hohmann, Elevatore per ossa.....	517
Langenbeck, Coltello per resezione.....	15
Langenbeck, Curetta auricolare.....	876
Langenbeck, Divaricatore.....	258-260
Langenbeck, Elevatore.....	512
Langenbeck, Periostotomo.....	500
Langenbeck, Portaghi.....	434
Langenbeck, Tenaglia per ossa.....	527
Langenbeck-Green, Divaricatore.....	260
Langenbeck-Mini, Divaricatore.....	243

Lawrence, Pinza per preparazione e legature	218	Manico universale	668, 830	McIntosh, Spatola per laringoscopia (luce fredda).....	392-393
Lazar, Micro-Pinza per legature.....	167	Manometro per salpingografo.....	835	McKenty, Elevatore per il setto nasale	907-908
Lebsche, Scalpello per sterno.....	556	Marquard, Pinza-sgorbia	540	McKenzie, Pinza per applicare le graffe.....	685
Lees, Pinza per bronchi.....	630	Martello.....	484-489	McQuigg-Mixter, Pinza per preparazione e legature	212
Legatore emorroidale.....	776	Martel-Rees, Pinza per Face-lift.....	185	Mead, Martello.....	486
Leksell-Stille, Pinza-sgorbia	542	Martin Aquajet, Pistola lavatrice a getto d'acqua	968	Mead, Pinza-sgorbia	537
Leland-Jones, Pinza vascolare periferale.....	617	Martin, Adattatore Luer.....	668	Meatotomo	794
Lempert, Curetta auricolare.....	879	Martin, Coltello per gesso.....	455	Meeker, Pinza per preparazione e legature	218
Lempert, Pinza-sgorbia	537	Martin, Diapason.....	867	Menghini, Cannula per la puntura del fegato	379
Lempert, Raspatario auricolare.....	879	Martin, Distributore per spazzole.....	948	Meniscotomo	520
Lerliche, Pinza emostatica	188	Martin, Divaricatore.....	254, 274	Metzenbaum, Forbici per dissezione	47-48,
Leva ostetrica	840	Martin, Divaricatore autostatico	321	Metzenbaum, Portaghi.....	413
Leva per corpi estranei.....	872, 877	Martin, Fissaggio di ottica.....	342	Metzenbaum-Aquila, Forbici per dissezione	49, 55
Lewin, Tenaglia per ossa	526	Martin, Gambio per tunnelare.....	668	Metzenbaum-Aquila-Fino, Forbici per dissezione	67, 70
Lewis, Raspa nasale	918	Martin, Giravite.....	668	Metzenbaum-Fino, Forbici per dissezione	66-71, 128, 130
Lexer, Forbici per dissezione.....	58, 60, 127	Martin, Manico universale	668	Metzenbaum-Lahay, Forbici per dissezione	128
Lexer, Osteotomo.....	473	Martin, Morsetto di fissaggio universale.....	342, 343	Metzenbaum-Nelson, Forbici per dissezione.....	52-54
Lexer, Scalpello per spongiosa	471	Martin, Oliva.....	668	Metzenbaum-TCC-BlackLine, Forbici per dissezione	49, 55
Lexer, Sgorbia	473	Martin, Pelvimetro.....	838	Metzenbaum-TCC-BlackLine-Fino, Forbici per dissezione	126
Lexer-Baby, Forbici per dissezione.....	64	Martin, Pinza per cartilagine.....	526	Metzenbaum-Thorek, Forbici per dissezione...127	
Lexer-Fino, Forbici fine per dissezione.....	65	Martin, Pinza per medicature	233	Meyerding, Divaricatore	244
Lexer-Mini, Osteotomo	472	Martin, Pinza per rifiuti.....	974	Michel, Graffe.....	445
Lexer-Mini, Sgorbia	472	Martin, Pinza vascolare periferale	600	Michel, Pinza per applicare le graffe	444
Leyla, Dispositivo alfixation	691	Martin, Pinza vascolare compasso.....	604	Michel, Specchi laringei	941
Leyla, Giunto a sfera.....	692, 693	Martin, Portaghi	427	Micro Ago auricolare.....	860-861
Leyla, Porta asta	692, 693	Martin, Set per tunnelare	668	Micro cucchiaio	708, 863
Leyla, Spatola cerebrale.....	690	Martin, Sistema braccio Martin.....	342	Micro Divaricatore	240, 708
Leyla, Supporto con diametro asse.....	691-692	Martin, Spatola addominale.....	344	Micro Forbici auricolare	854-855
Leyla, Testa di accoppiamento.....	691-693	Martin, Specolo nasale	885	Micro Pinza auricolare	848-853
Lichtenberg, Portaghi	418, 434	Martin, Tata adattatore veni.....	668	Micro pinze per dilatazione	162
Lillehei-Potts, Forbici per dissezione.....	123	Martin-Alloy, Diapason	867	Micro Portaghi	404-411, 418-423, 701
Lima per ossa	509-511, 917	Martin-Aseptic, Spazzola per unghie.....	948	Micro Portaghi	408, 411-420, 422-434, 436, 446-447
Lister, Forbici per bendaggi.....	450, 454	Martin-Cushing, Periostotomo.....	499	Micro Raspatore.....	706
Lister, Pinza per seni	233	Martin-Fuchsig, Pinza per preparazione e legature.....	192	Micro Raspatore auricolare.....	862
Liston, Cesoa per ossa	545	Martin-Hoen, Periostotomo.....	498	Micro Sonda per misurare	863
Liston-Key, Cesoa per ossa	549	Martini, Portaghi	430-431	Micro Uncino auricolare.....	860-862
Littauer, Forbici per legature	120	Martin-Langenbeck, Elevatore.....	512	Micro-bisturi vascolare.....	705
Littauer, Pinza depilatoria	169	Martin-Langenbeck, Periostotomo.....	498	Micro-dissettore	349, 705, 707, 862
Little, Divaricatore.....	261	Martin-Rochard, Barra trasversale	343	Micro-estrattore per flebiti.....	349
Lockhart-Mummery, Sonda per fistole	347	Martin-Rochard, Braccio di fissaggio.....	343	Micro-Forbici	79, 111-117, 698-700
Locklin, Forbici per gengiva.....	102	Martin-Rochard, Carrucola mobile.....	343	Micro-Forbici per dissezione.....	116, 699
Lockwood, Pinza per afferrare intestino e tessuti.....	751	Martin-Rochard, Divaricatore	343	Micro-Pinza	141, 153, 161-163, 165, 702
Logan, Divaricatore autostatico.....	299	Martin-Rochard, Sistema Divaricatore	343	Micro-Pinza atraumatica	165
Lorenz, Forbici per bendaggi	450	Martin-Rochard, Supporto per divaricatore.....	343	Micro-Pinza per dissezione con anello	162-163, 165
Lorna, Pinza fissateli	227	Maschera protettrice	952	Micro-Pinza per legature	167
Lovelace, Pinza emostatica	191	Masing, Elevatore per il periosto	910	Microvascular, Portaghi	430
Lovelace, Pinza per afferrare polmone	590	Masson, Portaghi.....	415, 426	Middeldorpf, Divaricatore	267, 271
Lower, Pinza per preparazione e legature	213	Mathieu, Divaricatore.....	297	Middleton-Jansen, Pinza per il setto nasale.....	899
Lubet-Barbon, Pinza per tamponamenti nasali	890	Mathieu, Pinza per corpi estranei.....	794	Mikro-Adson, Pinza emostatica	185
Lucae, Ago per timpano	878	Mathieu, Portaghi	417-418, 432-433	Mikro-Adson, Pinza per dissezione	155
Lucae, Diapason	868	Mayfield, Pinza-sgorbia.....	540	Mikro-Adson, Pinza per dissezione con denti.....	155
Lucae, Martello.....	485	Mayo, Forbici per dissezione	34-35	Mikro-Friedman, Pinza-sgorbia	538
Lucae, Uncino auricolare	877	Mayo, Pinza per dissezione con denti.....	34-35, 158	Mikro-Hegemann, Forbici per arteria coronaria	82
Luer, Pinza-sgorbia.....	539	Mayo, Pinze per sterilizzazione	960	Mikro-Mosquito, Pinza emostatica.....	188
Luer, Tubo di aspirazione	360, 364	Mayo-Blake, Pinza per calcoli biliari.....	782	Mikulicz, Mikulicz, Divaricatore	290, 291
Luer, Uncino tracheale.....	741	Mayo-Harrington, Forbici per dissezione	39	Mikulicz, Pinza per peritoneo	224-225
Lukens, Divaricatore per il timo	741	Mayo-Hegar, Portaghi.....	414, 425	Mikulicz-Baby, Pinza per peritoneo	224
Luniatschek, Tamponatori	934	Mayo-Lexer TCC-BlackLine, Forbici per dissezione.....	59	Miller, Lima per alveolotomia.....	511
		Mayo-Lexer, Forbici per dissezione.....	127	Miller, Set per laringoscopia.....	387
		Mayo-Lexer-Aquila, Forbici per dissezione.....	59	Miller, Set per laringoscopia (luce fredda).....	396
		Mayo-Noble, Forbici per dissezione	39	Miller, Spatola per laringoscopia	387
		Mayo-Robson, Pinza intestinale	756, 767	Miller, Spatola per laringoscopia (luce fredda).....	396-397
		Mayo-Stille, Forbici per dissezione	36-37	Miller-Baby, Set per laringoscopia	387
		Mayo-Stille, Forbici per dissezione	36-38	Miller-Colburn, Lima per ossa	510-511
		McDonald, Dissettore doppio	513	Millesi, Micro-Forbici	698
		McGee, Micro Uncino auricolare	861		
		McGee, Pinza per piegare fili metallici	856		
		McGinvey, Pinza per emorroidi.....	777		
		McIndoe, Forbici per neurchirurgia	92		
		McIndoe, Pinza per dissezione.....	140, 143		
		McIntosh, Set per laringoscopia.....	389		
		McIntosh, Set per laringoscopia (luce fredda).....	392		
		McIntosh, Spatola per laringoscopia.....	389		

Milligan, Dissetto per la dura-madre688
 Milligan, Divaricatore autostatico311
 Millin, Divaricatore del collo vescicale788
 Millin, Divaricatore vescicale789
 Millin, Pinza per afferare capsule786-787
 Millin, Pinza porta-filo787
 Mini Glover, Pinza per preparazione
 e legature181
 Mini-Adson, Pinza per dissezione con denti155
 Mini-clip vascolare175
 Mini-estrattore per flebiti349
 Mini-Gemini, Pinza per preparazione
 e legature207
 Mini-McGee, Micro Pinza auricolare849
 Mixter, Pinza per calcoli biliari783
 Mixter, Pinza per preparazione
 e legature210-212
 Mixter-Baby, Pinza per preparazione
 e legature185, 201, 209
 Mixter-O'Shaugnessy, Pinza per
 preparazione e legature210
 Mock, Ago per eparinea376, 379
 Mod. Bonn, Forbici per iridectomia104
 Mod. Martin, Pinza-coperchio960
 Mod. Martin, Protettore facciale952
 Mod. Martin, Sonda conduttrice441
 Mod. München, Curetta per biopsia825
 Mod. USA, Forbici ombelicale98
 Mod. Wien, Specolo nasale886
 Modell USA, Curetta tagliente494-495
 Modell Wien, Porta-legature443
 Mogen, Strumento per circoncisione793
 Moldenhauer, Leva per corpi estranei877
 Molla di ritenzione882
 Mollison, Divaricatore autostatico308
 Molt, Curetta497
 Molt, Curetta doppia497
 Morris-De Bakey, Pinza per aorta633
 Morse, Divaricatore per sterno563
 Morse-Favaloro, Divaricatore per sterno562
 Morsetto di fissaggio universale342, 343
 Moynihan, Pinza per isterectomia222
 Muehling, Periostotomo502
 Mueller, Clip vascolare179
 Müller, Approssimatore172-173
 Museux, Pinza per il collo dell'utero819

N

Nabatoff, Fune di trazione350
 Nabatoff, Mango solo350
 Nabatoff, Oliva350
 Nabatoff, Punta di plastica350
 Nabatoff, Set di sonde per varici350
 Nagel, Micro-Forbici700
 Nägele, Forcipe ostetrica838
 Neff, Meniscotomo520
 Negus, Pinza emostatica218
 Neivert, Portaghi412
 Neivert, Uncino per le pinne nasali923
 Neivert-Anderson, Osteotomo914
 Nelaton, Sonda cannellata347
 Nelson, Pinza per dissezione con denti159
 Nelson, Trequarto358
 Neuro, Diapason869
 Norfolk-Norwich, Divaricatore autostatico302
 Northbent, Forbici per legature119
 Noto, Pinza per polipi uterini821
 Novak, Curetta per aspirazione825
 Nuboer, Tubo di aspirazione372

O

Occhiali protettivi952
 Ochsner, Pinza per aorta595
 O'Connor, Divaricatore per pelle241
 Oehler, Pinza per dissezione con denti146
 Ogura, Pinza per afferare la pelle925
 Oldberg, Pinza per ipofisi732
 Oliva348, 350, 367, 668
 Oliva auricolare881
 Oliva in metallo882

Oliva nasale881
 Oliva uretrale380
 Olivecrona, Dissetto per
 la dura-madre686-687
 Olivecrona, Forbici per il nervo trigemino92
 Olivecrona-Tönnis, Pinza per
 applicare le graffe685
 Ollier, Divaricatore255
 Olsen-Hegar, Portaghi417, 431
 O'Shaugnessy, Pinza per preparazione
 e legature210
 Osteotomo465, 468-469, 472-477,
480-481, 912-914
 O'Sullivan-O'Connor,
 Divaricatore addominale336
 Otis, Lama di ricambio792
 Otis, Uretrotomo792
 Overholt-Baby, Pinza per preparazione
 e legature190
 Overholt-Fino, Pinza per preparazione
 e legature205-206
 Overholt-Geissendörfer, Pinza per
 preparazione e legature204
 Overholt-Martin, Pinza per
 preparazione e legature200
 Overholt-Mini, Pinza per
 preparazione e legature206
 Overholt-Mixter, Pinza per
 preparazione e legature201

P

Pallone in gomma con valva880
 Papavero-Caspar, Speculum ipofisi733
 Parker, Divaricatore296
 Parker-Langenbeck, Divaricatore297
 Parker-Mott, Divaricatore296
 Parkes, Osteotomo914
 Parte centrale con palla880
 Partsch, Martello486
 Partsch, Scalpello466
 Partsch, Sgorbia466
 Payr, Schiacciatore intestinale759
 Payr, Sonda conduttrice443
 Payr-Baby, Schiacciatore intestinale759
 Pean (Rochester), Pinza emostatica196-197
 Pean, Pinza emostatica182, 193, 446-447
 Pean-Nippon, Pinza emostatica193
 Peck-Joseph, Forbici per Face-lift75
 Pederson, Specolo vaginale799
 Peers-Bertram modif., Pinza fissateli227
 Peers-Bertram, Pinza fissateli228
 Peet, Pinza per scheggie170
 Pelvimetro838
 Penfield, Dissetto per la dura-madre689
 Pennington, Elevatore per il setto nasale910
 Pennington, Pinza emostatica184
 Pera di gomma880
 Pera in gomma881
 Percy, Retrattore per amputazione535
 Periostotomo498-506, 508
 Periostotomo costali507
 Pesi869
 Peso per specolo vaginale808-809
 Pestalozza, Cucchiato per placenta e ovaie842
 Pestone metallico483
 Pezzo di collegamento834
 Phaneuf, Pinza per isterectomia219
 Pierse, Micro-Pinza162
 Pierse, Pinza micro con contrapeso162
 Pietra per affilare16
 Pinza atraumatica142, 147-148
 Pinza auricolare871
 Pinza Bulldog176-181, 589,
590-592, 611-612
 Pinza carotis593
 Pinza carotis599
 Pinza con rotelle230
 Pinza contundente per il setto nasale899-900
 Pinza da orologio156
 Pinza depilatoria169

Pinza emostatica182-199, 218,
446-447, 594, 638
 Pinza emostatiche per tagli cesarei840
 Pinza etmoidale892-895
 Pinza fissateli226-228, 446-447
 Pinza gastrointestinali gemelle763-764
 Pinza iliaca658
 Pinza intercambiabile per
 bronco-esofagoscopia938-939
 Pinza intestinale754-758, 766-770
 Pinza micro con contrapeso162, 164
 Pinza osteotomo874-875
 Pinza passa-tendini523
 Pinza per afferare capsule786-787
 Pinza per afferare e rompere
 le lamatte di rasoio4
 Pinza per afferare e rompere
 le lamatte di rasoio4
 Pinza per afferare intestino e tessuti750-754
 Pinza per afferare l'utero823
 Pinza per afferare la pelle925
 Pinza per afferare organi183-184, 765
 Pinza per afferare polmone590
 Pinza per afferare tendini523, 524
 Pinza per afferare tubi159
 Pinza per afferare tumori184, 732
 Pinza per allacciare tendini524
 Pinza per anastomosi615, 631-632, 642,
657-658, 660, 662, 664
 Pinza per anastomosi intestinali760, 762
 Pinza per anastomosi rettili770-773
 Pinza per aneurisma634
 Pinza per aneurisma della aorta619-620
 Pinza per aorta595, 601-602, 606-609,
621, 624-625, 633, 655
 Pinza per applicare clips vascolari172, 175
 Pinza per applicare e togliere le graffe444, 685
 Pinza per biopsia826-830
 Pinza per biopsia rettale777
 Pinza per bronchi587-588, 630
 Pinza per calcoli biliari782-783
 Pinza per calcoli renali780
 Pinza per carotis659
 Pinza per cartilagine525-526
 Pinza per cateteri604-605
 Pinza per coartazione613-614
 Pinza per columella925
 Pinza per corpi estranei794, 872
 Pinza per craniectomia684
 Pinza per dissezione138-147, 154-155,
160, 446-447
 Pinza per dissezione con denti143-144,
146-147, 149-155, 157-160, 446-447
 Pinza per dissezione con denti158, 702-703
 Pinza per dissezione vascolare610-611, 656
 Pinza per DIU830
 Pinza per emorroidi777
 Pinza per Face-lift185, 747
 Pinza per gesso456
 Pinza per gozzo742
 Pinza per i margini della ferita444
 Pinza per il collo dell'utero817-820
 Pinza per il cuoio capelluto685
 Pinza per il rene e pancreas627
 Pinza per il setto nasale891, 899, 924
 Pinza per introdurre le sonde386
 Pinza per introduzione858
 Pinza per ipofisi731-732
 Pinza per isterectomia219-220, 222-223
 Pinza per legature185-186, 622-623
 Pinza per medicature235, 890
 Pinza per microscopia168
 Pinza per occlusione tangenziale628
 Pinza per peduncoli renali214-215
 Pinza per peritoneo224-225
 Pinza per piegare fili metallici856
 Pinza per placenta e per ovaie840
 Pinza per polipi auricolari872-873
 Pinza per polipi laringei942
 Pinza per polipi nasali890

Pinza per polipi uterini	821	Potts-Smith, Pinza per dissezione	142, 145	Roux-Mini, Divaricatore	295
Pinza per posizionare	612	Potts-Smith, Pinza per dissezione con denti	154	Rubin, Calotta protettiva	900
Pinza per preparazione e legature	181, 185,	Pratt, Pinza emostatica	184	Rubin, Osteotomo	913
.....190, 192, 200-213, 217-218		Pratt, Specolo rettale	774	Rubin, Pinza contundente	
Pinza per preparazioni e legature	615	Price-Thomas, Pinza per bronchi	587	per il setto nasale	900
Pinza per raddizzare il setto nasale	924	Prottettore facciale	952	Rubinetto	380
Pinza per rifiuti	974	Providence-Hospital, Pinza emostatica	188	Rubinetto a tre vie	380
Pinza per riposizioni	526, 528	Punta a bottone	882	Rudd, Cono per caricare	776
Pinza per rompere gesso	457	Punta conica	882	Rudd, Legatore emorroidale	776
Pinza per scheggie	166-168, 170	Punta di plastica	350	Rumel, Pinza per preparazione e legature	208
Pinza per seni	233	Punta di ricambio	683	Rumel-Belmont, Tornichetto	671
Pinza per strumenti sterilizzazione	956	Punta filettata	882	Ruskin, Pinza-sgorbia	540
Pinza per tamponamenti nasali	890	Punta per aspirazione	362, 367, 373	Ruskin-Liston, Cesoia per ossa	547
Pinza per tamponi	232-234, 446-447	Punta, sola	830	Russ. Modell, Pinza per dissezione	
Pinza per tamponi e sponge	235-237	Putti, Raspa per ossa	482	con denti	157
Pinza per testa del martelletto	857	Q		Rydel-Seiffert, Diapason	869
Pinza per tonsille	935, 937	Quattro, Pinza per gesso	456	Ryder (Martin), Portaghi	427
Pinza per trazione craniale	683	Quervain, Elevatore	513	Ryder-Vascular, Portaghi	428
Pinza per tunnelare	234	Quire, Leva per corpi estranei	872		
Pinza per vie biliari	213, 216				
Pinza porta-filo	787	R			
Pinza profonda	598	Raccordo	380	Saalfeld, Tiracomodoni	746
Pinza serratubi	228-229	Raccordo di lavaggio	972-973	Sachs, Dissettore per la dura-madre	687
Pinza tagliente per il naso	893-894, 896, 898	Raccordo per tubi	380	Sachs, Uncino per dura-madre	696-697
Pinza tagliente per laminectomia	712-723	Ragnell, Forbici per dissezione	135	Sachse, Calibro	794
Pinza tagliente per seno mascellare	897, 904	Ragnell-Davis, Divaricatore	245	Sachse, Meatotomo	794
Pinza tagliente per seno sfenoidale	901-903	Ralk, Pinza per scheggie	170	Salenius, Meniscotomo	520
Pinza taglienti per aorta	557	Ramplé, Pinza per tamponi e sponge	237	Salpingografo	835
Pinza tangenziali	214	Randall, Pinza per calcoli renali	780	Salzer, Dissettore per palato	932
Pinza vascolare pediatrica	643-646, 649,	Raney, Pinza per applicare		Salzer, Elevatore per palato	932
.....657, 673-676		e togliere le graffe	685	Salzer, Forbici per dissezione	72, 119
Pinza vascolare per neonati	675, 677	Raney, Pinza per il cuoio capelluto	685	Salzer, Uncino per palato	932
Pinza vascolare periferale	597, 600,	Raschiatoio per lupus	744	Samii, Bisturi tumore	704
.....603, 616-617		Rasoio	16	Samii, Micro-bisturi vascolare	705
Pinza vascolare universale	596, 618,	Raspa nasale	917-920	Samii, Pinze afferarre	702
.....635-637, 639-642, 647-648,		Raspa per glabella	918	Sänger, Pinza per placenta e per ovaie	840
.....650-654, 659-664		Raspa per ossa	482	Santulli, Pinza Bulldog	592
Pinza vascolari	203, 627	Raspa per seno mascellare	917	Sanvenero, Forbici per chirurgia	72
Pinza ventricolare	629	Raspatore per palato	907, 932	Sarot, Pinza per preparazione e legature	202
Pinza vscolare compasso	604	Raspatore per aspiratore	926	Sarot, Portaghi	425
Pinza-coperchio	960	Raspe, Divaricatore per ossa	240	Satinsky, Forbici vascolare	80
Pinza-sgorbia	536-544	Rasse, Micro Divaricatore	240	Satinsky, Pinza per occlusione tangenziale	628
Pinze afferarre	704	Recamier, Curetta uterina	832	Satinsky, Pinza vascolari	627
Pinze drenaggio	557	Recipiente metallico	964	Sauerbruch, Costotomo	555
Pinze guide-fil	706	Record-Arkansas, Pietra per affilare	16	Sauerbruch, Divaricatore	277, 280
Pinze nasale	870	Redon, Ago conduttore	374-375	Sauerbruch, Pinza per rifiuti	974
Pinze per il fegato	626	Rees, Forbici per Face-lift	131	Sauerbruch, Pinza-sgorbia	544
Pinze per laminectomia	724-731	Reiner, Coltello per gesso	455	Sauerbruch, Scatola per aghi	957
Pinze per sterilizzazione	960	Resano, Pinza per anastomosi rettali	773	Scalp-Contour, Divaricatore autostatico	301
Pinze per Vena Cava	625	Resano, Pinza per dissezione con denti	159	Scalpello	465-468, 480
Pinze tumori	702	Retratore per amputazione	535	Scalpello	464
Piper, Forcipe obstetrica	839	Reverdin, Ago di Reverdin	435	Scalpello	464, 913
Pistola lavatrice a getto d'acqua	968	Reynolds, Forbici per dissezione	77-78	Scalpello nasale	914
Pittsburgh, Pinze per il fegato	626	Ricard, Divaricatore addominale	327	Scalpello per cranio	464
Piuma	322	Ricard, Divaricatore, solo	327	Scalpello per stengiosa	471
Placca di ricambio	486-488	Ricard, Valva centrale	327	Scalpello per sterno	556
Placca per stendere la pelle	17	Ricaricatore induttivo	400	Scatola per aghi	961-963
Plester, Coltello per lobi	859	Richardson, Divaricatore	268	Scatola per laringoscopia	391
Plester, Divaricatore autostatico	309	Richardson-Eastman, Divaricatore	267	Scatola per strumenti	812, 968, 965
Plester, Tubo di aspirazione	378	Richter, Pinza per applicare le graffe	444	Schädel, Pinza fissateli	226
Politzer, Ago per timpano	878	Richter, Pinze per laminectomia	731	Schamberg, Tiracomodoni	746
Politzer, Cono di connessione	881	Ritter-Halle, Dilatatore per il seno frontale	926	Schede, Curetta tagliente	491
Politzer, Insoffiatore d'aria	881	Robb, Dissettore vascolare	670	Scheibe, Pinza per afferare organi	765
Politzer, Oliva auricolare	881	Roberts, Pinza per preparazione e legature	202	Scheinmann, Pinza intercambiabile	
Politzer, Oliva nasale	881	Rochester-Carmalt, Pinza emostatica	192	per bronco-esofagoscopia	938
Politzer, Pera in gomma	881	Roeder, Pinza fissateli	227	Scherbak, Manico per	
Polloson, Divaricatore	283, 284	Roger, Elevatore per il periosto	910	specolo vaginale	807, 808
Poole, Tubo di aspirazione	368	Rogers, Pinza per isterectomia	221	Scherbak, Peso per specolo vaginale	808
Poppen, Tubo di aspirazione	362	Rose, Uncino tracheale	741	Scherbak, Specolo vaginale	808
Portacottone	352	Rosen, Coltello circolare	859	Scherbak, Valva vaginale, sola	807
Porta-fili	870	Rosen, Micro Ago auricolare	860	Schiacciatore intestinale	759
Porta-legature	443, 671	Rosenberg, Pinza intercambiabile		Schink, Dermatomo	17
Portapinze	761	per bronco-esofagoscopia	939	Schink, Lama di ricambio	17
Potts, Micro-Forbici	114	Ross, Divaricatore per aorta	281-282	Schink, Placca per stendere la pelle	17
Potts, Pinza per anastomosi	615	Roux, Divaricatore	294	Schmeden, Pinza tagliente per il naso	898
Potts, Pinza per coartazione	613-614	Roux-Baby, Divaricatore	295	Schmid, Cannula per irrigazione vascolare	379
Potts, Pinza vascolare universale	635			Schmieden, Ago per legatura	436
Potts-De Martell-Highmed,				Schmieden, Sonda conduttrice	442
Forbici per dissezione	123			Schmieden-Dick, Ago per legatura	436
Potts-Smith, Forbici vascolare	83			Schmieden-Payr, Sonda conduttrice	442

- Schmieden-Taylor, Forbici per dura madre90
 Schneider, Periototomo501
 Schnidt, Pinza per preparazione e legature192
 Schnidt, Pinza per tonsille935
 Schröder, Pinza per il collo dell'utero817-818
 Schubert, Pinza per biopsia826-827
 Schuhmacher, Forbici ombelicale98
 Schuknecht, Coltello falcato come sinechia859
 Schultze, Manometro per salpingografo835
 Schultze, Salpingografo835
 Schumacher, Pinza intercambiabile
 per bronco-esofagoscopia939
 Schumacher, Pinza per biopsia829-830
 Schumacher, Punta, sola830
 Scodella rotonda966, 963
 Scollatendini521-522
 Scoville, Curetta tagliente493
 Scoville, Divaricatore per laminectomia340
 Scoville, Uncino341
 Scoville, Valva341
 Scoville-Haverfield, Divaricatore
 per laminectomia340
 Scudder, Pinza intestinale770
 Sebileau, Elevatore513
 Secchio per rifiuti974
 Sedillot, Periototomo501, 504
 Sega da filo di ferro682
 Sega nasale915
 Sega oscillata per gesso458
 Segond, Bisturi per fibromi822
 Seiffert, Pinza intercambiabile
 per bronco-esofagoscopia938
 Sellheim, Leva ostetrica840
 Sellers, Approssimatore costale584
 Semb, Cesoa per ossa549
 Semb, Periototomo508
 Semb, Pinza per bronchi588
 Semb, Pinza-sgorbia540
 Semb, Tenaglia per ossa529
 Semken, Pinza per dissezione141
 Semken, Pinza per dissezione
 con denti143, 152
 Semm, Specolo vaginale799
 Senn-Green, Divaricatore245
 Senn-Miller, Divaricatore245
 Separatore per osso710
 Separatore per vertebre710-711
 Serranodi870, 888
 Serranodi per tonsille936
 Serrapene795
 Serrapinze760
 Serrapinze e portapinze762
 Serratura per pinze intestinali762
 Set "Piccole ferrite"446
 Set di manicura per infermieri950
 Set di sonde per varici348, 350
 Set per laringoscopia387-390
 Set per laringoscopia
 (luce fredda)392, 394, 396
 Set per tunnelare668
 Sewall, Periototomo501
 Sfincteroscopia776
 Sgorbia464-467, 469, 472-473,
 478-479, 481, 913
 Sgorbia per il setto nasale911
 Shaaf, Pinza per scheggie168
 Shambaugh, Micro Uncino auricolare862
 Shapleigh, Curetta auricolare876
 Shea Vein Graft, Forbici per dissezione75
 Shea, Uncino di sondaggio862
 Silver, Dermatomo a mano17
 Silver, Scalpello nasale914
 Simon, Curetta tagliente493
 Simon, Curetta uterina831
 Simon, Divaricatore274
 Simon, Uncino per fistole824
 Simpson, Forcipe obstetrica838
 Sims, Curetta uterina832
 Sims, Forbici per ginecologia40-41
 Sims, Isterometro816
 Sims, Specolo rettale774
 Sims, Specolo vaginale800
 Sims-Aquila, Forbici per utero41
 Sims-Siebold, Forbici per ginecologia45
 Sims-TCC-BlackLine, Forbici per utero41
 Singley-Tuttle, Pinza per dissezione
 con denti158
 Siringa381, 882
 Siringa auricolare882-883
 Siringa da tre anelli382
 Siringa per insulina382
 Siringa per tuberculina383
 Siringa per vescica e ferite384
 Sistema braccio Martin342
 Sistema Divaricatore343
 Skene, Pinza per il collo dell'utero818
 Smillie, Meniscotomo520
 Smith-Petersen, Osteotomo477
 Smith-Petersen, Sgorbia478
 Smithwick, Uncino per nervi695
 Snyder-O.S.U., Sgorbia464
 Somer, Pinza per afferrare l'utero823
 Sonda845
 Sonda a bottone346, 708
 Sonda a foglia di mirto346
 Sonda auricolare346, 870
 Sonda cannellata347
 Sonda conduttrice440-443
 Sonda conduttrice per tendini522
 Sonda metallica, per donne791
 Sonda per fistole347
 Sonda per gozzo742
 Sordina869
 Spatol694
 Spatola addominale293, 344
 Spatola cerebrale690
 Spatola per fasciotomia669
 Spatola per intima670
 Spatola per laringoscopia387-391
 Spatola per laringoscopia
 (luce fredda)392-393, 395-397
 Spatola per pulmone586
 Spazzola per pulire974-977
 Spazzola per unghie948
 Specchi laringei940-941
 Specolo auricolare864-865
 Specolo nasale884-887
 Specolo rettale774
 Specolo vaginale798-810
 Speculum ipofisi733
 Spencer, Forbici per legature119-120
 Spencer-Wells, Pinza emostatica182
 Spratt, Curetta tagliente492
 St. Barts, Pinza etmoidale895
 St. Marks, Divaricatore pelvico292-293
 Stacke, Sonda auricolare346
 Stella-S, Forbici Face-lift747
 Stellbrink, Pinza-sgorbia536
 Stevens, Forbici per chirurgia108-109
 Stevens, Forbici per tenotomia108-109
 Stieglitz, Pinza per scheggie170
 Stille, Osteotomo468-469
 Stille, Pinza per dissezione139
 Stille, Pinza per dissezione con denti151
 Stille, Pinza-sgorbia540
 Stille, Scalpello468
 Stille, Sgorbia469
 Stille-Barraya, Pinza per dissezione
 con denti157
 Stille-Liston, Cesoa per ossa547-548
 Stille-Luer, Pinza-sgorbia543
 Stille-Martin, Forbici per gesso453
 Stille-Ruskin, Pinza-sgorbia541
 Stockmann, Serrapene795
 Stone-Watt, Pinza per anastomosi
 intestinali762
 Stone-Watt, Serrapinze e portapinze762
 Stone-Watt, Serratura per pinze intestinali762
 Strandell-Stille, Divaricatore248
 Stratte, Portaghi416, 429-430
 Strauss, Serrapene795
 Stripper anello351
 Strully, Forbici per neurchirurgia90
 Strumento per circonconcisione793
 Strumento per uretrografia793
 Strumento tira tendini521
 Strümpel, Pinza per polipi auricolari873
 Struycken, Pinza tagliente per il naso896
 Stuoia in silicone959
 Subramanian, Pinza per aorta672
 Subramanian-Miniature, Pinza per aorta672
 Supporto con diametro asse691-692
 Supporto di guida per osteotomi916
 Supporto per divaricatore343
 Supporto per luce fredda775
 Supporto per piatti Petri956
 Supporto per spatola690-692
 Supporto per specoli auricolari865
T
 Tabb, Bisturi per mucosa859
 Takahashi, Pinza etmoidale892
 Tamponatori934
 Tata adattatore veni668
 Taylor, Divaricatore spinale519
 Taylor, Pinza per dissezione141
 Taylor, Pinza per dissezione con denti153
 Taylor, Valva341
 TCC-BlackLine,
 Forbici per isterectomia132-133
 Teale, Pinza per il collo dell'utero818
 Tenaglia per ossa525 535
 Testa di accoppiamento691-693
 Thoms-Allis, Pinza per afferrare
 intestino e tessuti751
 Thoms-Gaylor, Pinza per biopsia827
 Thorek, Forbici per dissezione63
 Tieck-Halle, Specolo nasale885
 Tiracomodon746
 Tiramiomi822
 Toennis, Dissetto per la dura-madre686
 Toennis, Forbici per dissezione91
 Toennis, Portaghi418, 433
 Toennis-Adson, Forbici per dissezione91, 129
 Tohoku, Pinza fissateli227, 446-447
 Tönnis-Adson TCC-BlackLine,
 Forbici per dissezione129
 Tönnis-Adson-Aquila,
 Forbici per dissezione129
 Torchio per cartilagine916
 Torcifilo443
 Tornichetto671
 Toynee, Specolo auricolare, set864
 Trefina cutanea745
 Trelat, Periototomo500
 Trelat, Specolo vaginale799
 Trequarto358
 Trölttsch (Wilde), Pinza auricolare871
 Trölttsch, Pinza per medicature890
 Tronchesino per pelle951
 Tronchesino per unghie954, 951
 Trousseau, Dilatatore per tracheotomia740
 Troutman-Chris, Pinza per afferrare
 e rompere le lamatte de rasoio4
 Tubbs, Dilatatore per aorta665
 Tubo allunghi830
 Tubo di aspirazione348, 359-363
 361, 364-365, 367-369,
 372-373, 377-378
 Tubo di connessione380, 795, 882
 Tubo laringeo937, 938, 939
 Tuffier, Divaricatore costale563
 Tuffier, Pinza emostatica183
 Tuohy, Cannula per puntura lumbale377
 Turnbull, Tronchesino per unghie950
 Tyding, Serranodi per tonsille936

U

Ulrich, Pinza per tamponi	232
Ulrich, Tenaglia per ossa	531
Uncino	341
Uncino auricolare	877-878
Uncino di sondaggio	862
Uncino face-lift	745
Uncino nasale	921
Uncino per dura-madre	696-697
Uncino per fistole	824
Uncino per le pinne nasali	921-923
Uncino per mucosa	921-922
Uncino per nervi	671, 695
Uncino per palato	932
Uncino tracheale	741
Uncino per nervi e vasi	709
Universal, Forbici per bendaggi	452
Universal, Forbici per tagliare fili metallico	121
Universal, Insoffiatore polvere	880
Universal, Trequarto	358
Unna, Tiracomedoni	746
Unna-Vidal, Tiracomedoni	746
Uretrotomo	792

V

Valleix, Isterometro	816
Valva	315-316, 337-339, 341
Valva centrale	312, 322, 325-327, 330-336, 775, 789
Valva di filo	335
Valva laterale	324-329, 558, 565-571, 573-574, 577-582
Valva vaginale	801-805, 810
Valva vaginale, sola	807
Valvola di connessione	882
Van Buren, Candeletta dilatatrice	790
Van Doren, Pinza per biopsia	828
Vannas, Micro-Forbici	698
Varady, Flebo-dissetto	349
Varady, Flebo-estrattore	349
Varady, Micro-estrattore per flebiti	349
Varady, Mini-estrattore per flebiti	349
Varady, Oliva	348
Varady, Set di sonde per varici	348
Veidenheimer, Pinza per anastomosi rettali	772
Verbrugge, Tenaglia per ossa	534, 535
Verhoeven, Tubo di aspirazione	377
Verres, Cannula per insufflazione	378
Vetro di sostituzione	949
Vickers Low-Profile, Divaricatore autostatico	322
Vickers Low-Profile, Valva centrale	322
Vickers, Divaricatore autostatico	322
Vidal, Raschiatoio per lupus	744
Virchow, Coltello per il cervello	3
Virchow, Scalpello per cranio	464
Vite	521
Vite a testa zigrinata	869
Vite di ricambio	470
Volkman, Curetta doppia	496
Volkman, Curetta tagliente	490, 491
Volkman, Divaricatore	250-252
Vollmar, Cannula per irrigazione vascolare	378
Vollmar, Stripper anello	351

W

Wachenfeldt, Pinza per applicare le graffe	444
Wagener, Uncino auricolare	878
Wagner, Forbici per chirurgia	100
Wagner, Pinze per laminectomia	730
Waldmann, Forbici per episiotomia	97
Walter, Osteotomo	913
Walter, Sgorbia	913
Wangensteen, Pinza per dissezione	146
Wangensteen, Portaghi	416, 428
Wassmund, Divaricatore	256
Watson-Cheyne, Dissetto doppio	513
Watson-Williams, Pinza etmoidale	893
Waugh, Pinza per dissezione	140
Waugh, Pinza per dissezione con denti	152
Weber, Pinza per aorta	624

Weber-Loch, Ansa auricolare	877
Webster, Portaghi	412, 419, 423-424
Weil, Pinza tagliente per il naso	893
Weil-Blakesley, Pinza etmoidale	894-895
Weil-Blakesley, Pinza tagliente per il naso	894
Weissbarth, Crivello per specola vaginale	810
Weissbarth, Specolo vaginale	810
Weitlaner, Divaricatore autostatico	30, 303, 306-307, 446-447
Weitlaner-Baby, Divaricatore autostatico	311
Weitlaner-Wullstein, Divaricatore autostatico	308
Wertheim, Forbici per ginecologia	46
Wertheim, Pinza per isterectomia	223
Wertheim-Cullen, Pinza vaginale	220
Westcott, Forbici per strabismo	110
Westmacott, Pinza per tamponamenti nasali	890
White, Pinza per tonsille	935
Wikstroem, Pinza per preparazione e legature	211
Williams, Divaricatore autostatico	310
Williams, Pinza per afferare intestino e tessuti	752
Williger, Curetta doppia	497
Williger, Elevatore	513
Williger, Martello	484, 486
Williger, Periostotomo	505
Winter, Pinza per placenta e per ovaie	840
Wolff, Curetta per lupus	744
Wolff, Pinza per rompere gesso	457
Wrigley, Forcipe obstetrica	838
Wullstein, Cannula d' aspirazione	363
Wullstein, Coltello falcato come sinechia	859
Wullstein, Micro Forbici auricolare	855
Wullstein, Tubo di aspirazione	363
Wylie, Pinza per aorta	601, 625

Y

Yankauer, Manico	367
Yankauer, Oliva	367
Yankauer, Punta per aspirazione	367
Yankauer, Tubo di aspirazione	366, 367
Yankauer, Tubo di aspirazione	367
Yasargil, Divaricatore Galea	686
Yasargil, forchetta tumore	704
Yasargil, Micro cucchiaino	708
Yasargil, Micro Dissetto	707
Yasargil, Micro Portaghi	701
Yasargil, Micro Raspatore	706
Yasargil, Micro-bisturi vascolare	705
Yasargil, Micro-Forbici	699
Yasargil, Micro-Forbici per dissezione	699
Yasargil, Micro-Pinza	702
Yasargil, Pinza per ipofisi	731, 732
Yasargil, Pinze afferarre	702
Yasargil, Pinze guide-fil	706
Yasargil, Pinze tumori	702
Yasargil, Tubo di aspirazione	365
Yasargil-Samii, Pinze afferarre	702
Young, Ago di ricambio	436
Young, Divaricatore prostatico	785
Young, Portaghi	436

Z

Zanger, Pinza per aorta	606
Zaufal, Leva per corpi estranei	877
Zaufal-Jansen, Pinza-sgorbia	539
Zeller, Occhiali protettivi	952
Zenker, Divaricatore	265
Zenker, Pinza per preparazione e legature	209
Zielke, Sgorbia	467
Zoccolo	868
Zöllner, Punta per aspirazione	362
Zöllner, Specolo auricolare	865
Zöllner, Specolo auricolare, set	865
Zöllner, Tubo di aspirazione	362
Zweifel, Portaghi	434

KLS Martin Group

KLS Martin France SARL
68200 Mulhouse · France
Tel. +33 3 89 51 3150
france@klsmartin.com

KLS Martin UK Ltd.
Reading RG1 3EU · United Kingdom
Tel. +44 1189 000 570
uk@klsmartin.com

KLS Martin do Brasil Ltda.
CEP 04.531-011 São Paulo · Brazil
Tel.: +55 11 3554 2299
brazil@klsmartin.com

Gebrüder Martin GmbH & Co. KG
Representative Office
121471 Moscow · Russia
Tel. +7 499 792-76-19
russia@klsmartin.com

Martin Italia S.r.l.
20864 Agrate Brianza (MB) · Italy
Tel. +39 039 605 6731
italia@klsmartin.com

Nippon Martin K.K.
Osaka 541-0046 · Japan
Tel. +81 6 6228 9075
nippon@klsmartin.com

KLS Martin Australia Pty Limited
Artarmon NSW 2064 · Australia
Tel.: +61 2 9439 5316
australia@klsmartin.com

Gebrüder Martin GmbH & Co. KG
Representative Office
201203 Shanghai · China
Tel. +86 21 5820 6251
china@klsmartin.com

Martin Nederland/Marned B.V.
1271 AG Huizen · The Netherlands
Tel. +31 35 523 4538
nederland@klsmartin.com

KLS Martin L.P.
Jacksonville, FL 32246 · USA
Tel. +1 904 641 7746
usa@klsmartin.com

KLS Martin SE Asia Sdn. Bhd.
14100 Simpang Ampat, Penang · Malaysia
Tel.: +604 505 7838
malaysia@klsmartin.com

Gebrüder Martin GmbH & Co. KG
Representative Office
Dubai · United Arab Emirates
Tel. +971 4 454 16 55
middleeast@klsmartin.com

Gebrüder Martin GmbH & Co. KG

Ein Unternehmen der KLS Martin Group

KLS Martin Platz 1 · 78532 Tuttlingen · Germany
Postfach 60 · 78501 Tuttlingen · Germany
Tel. +49 7461 706-0 · Fax +49 7461 706-193
info@klsmartin.com · www.klsmartin.com