

## Product catalog 2020

# Anterior Cruciate Ligament reconstruction

## LIGAFIX® interference screws

LIGAFIX® are bioabsorbable interference screws designed for tibial and femoral fixation in ligament reconstructions. Made of Duosorb® material ( $\beta$ -TCP & PDLA), LIGAFIX® implants are osteoconductive and prevent inflammatory reactions<sup>18</sup>: LIGAFIX® 30 (30%  $\beta$ -TCP) is preferred for Bone-Tendon-Bone grafts while LIGAFIX® 60 (unique 60%  $\beta$ -TCP) is optimized for hamstring grafts. LIGAFIX® screws are available in various diameters, lengths, composition and design, providing you with the right implant for your surgical technique. <sup>6, 12</sup>

### LIGAFIX® 30

The diameter of the tunnel drilling has to be adapted to the screw's diameter and to the technique:

BTB:  $\varnothing$  of the screw inferior of 1 mm to  $\varnothing$  of the drill.

Hamstrings:  $\varnothing$  of the screw equal to  $\varnothing$  of the drill.

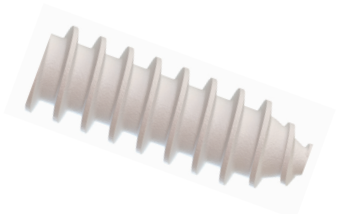
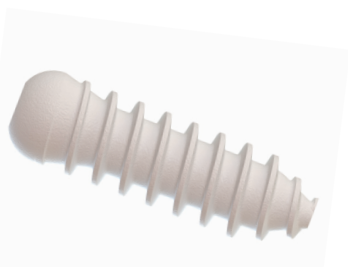
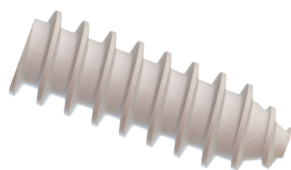
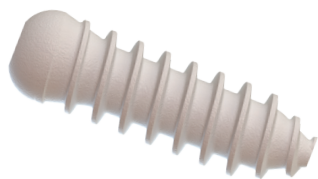

### LIGAFIX® 60

Only for hamstring grafts.

The diameter of the screw has to be lower or equal to the drill's diameter.

#### Round head LIGAFIX® 30

$\varnothing$  6 mm, L 20 mm - COM3006020  
 $\varnothing$  7 mm, L 20 mm - COM3007020  
 $\varnothing$  7 mm, L 25 mm - COM3007025  
 $\varnothing$  7 mm, L 30 mm - COM3007030  
 $\varnothing$  8 mm, L 20 mm - COM3008020  
 $\varnothing$  8 mm, L 25 mm - COM3008025  
 $\varnothing$  8 mm, L 30 mm - COM3008030  
 $\varnothing$  8 mm, L 35 mm - COM3008035  
 $\varnothing$  9 mm, L 20 mm - COM3009020  
 $\varnothing$  9 mm, L 25 mm - COM3009025  
 $\varnothing$  9 mm, L 30 mm - COM3009030  
 $\varnothing$  9 mm, L 35 mm - COM3009035  
 $\varnothing$  10 mm, L 25 mm - COM3010R25  
 $\varnothing$  10 mm, L 30 mm - COM3010R30  
 $\varnothing$  10 mm, L 33 mm - COM3010R33  
 $\varnothing$  10 mm, L 35 mm - COM3010R35

#### Flat head LIGAFIX® 30 (only for tibia)

$\varnothing$  10 mm, L 30 mm - COM3010030  
 $\varnothing$  10 mm, L 35 mm - COM3010035  
 $\varnothing$  11 mm, L 30 mm - COM3011030  
 $\varnothing$  11 mm, L 35 mm - COM3011035

#### Round head LIGAFIX® 60

$\varnothing$  7 mm, L 20 mm - COM6007020  
 $\varnothing$  7 mm, L 25 mm - COM6007025  
 $\varnothing$  7 mm, L 30 mm - COM6007030  
 $\varnothing$  8 mm, L 20 mm - COM6008020  
 $\varnothing$  8 mm, L 25 mm - COM6008025  
 $\varnothing$  8 mm, L 30 mm - COM6008030  
 $\varnothing$  8 mm, L 35 mm - COM6008035  
 $\varnothing$  9 mm, L 20 mm - COM6009020  
 $\varnothing$  9 mm, L 25 mm - COM6009025  
 $\varnothing$  9 mm, L 30 mm - COM6009030  
 $\varnothing$  9 mm, L 35 mm - COM6009035  
 $\varnothing$  10 mm, L 25 mm - COM6010R25  
 $\varnothing$  10 mm, L 30 mm - COM6010R30  
 $\varnothing$  10 mm, L 33 mm - COM6010R33  
 $\varnothing$  10 mm, L 35 mm - COM6010R35

#### Flat head LIGAFIX® 60 (only for tibia)

$\varnothing$  10 mm, L 30 mm - COM6010030  
 $\varnothing$  10 mm, L 35 mm - COM6010035  
 $\varnothing$  11 mm, L 30 mm - COM6011030  
 $\varnothing$  11 mm, L 35 mm - COM6011035

## LIGAFIX® instruments



#### Guide pin introducer for guide pin $\varnothing$ 0.9 mm

LIG9000092

#### Guide pin (K-Wire) $\varnothing$ 2.5 mm for drill bits

LIG9125300-01 (x1) / LIG9125300-05 (x5) / LIG9125300-10 (x10)

#### Rigid guide pin:

$\varnothing$  0.9 mm for  $\varnothing$  6, 7, 8 mm screwdriver

Lg 300 mm

LIG9109300-01 (x1) / LIG9109300-05 (x5) / LIG9109300-10 (x10)

Lg 400 mm

LIG9109400-01 (x1) / LIG9109400-05 (x5) / LIG9109400-10 (x10)

$\varnothing$  1.4 mm for  $\varnothing$  9, 10, 11 mm screwdriver

Lg 300 mm

LIG9114300-01 (x1) / LIG9114300-05 (x5) / LIG9114300-10 (x10)

Lg 400 mm

LIG9114400-01 (x1) / LIG9114400-05 (x5) / LIG9114400-10 (x10)

#### Tap:

Grey for  $\varnothing$  6 mm screws - LIG9000296 (optional)

White for  $\varnothing$  7 mm screws - LIG9000169

Black for  $\varnothing$  8, 9, 10, 11 mm screws - LIG9000093

#### Screwdriver:

Grey for  $\varnothing$  6 mm screws - LIG9009017 (optional)

Green for  $\varnothing$  7, 8 mm screws - LIG9008046

Blue for  $\varnothing$  9, 10, 11 mm screws - LIG9009017



## PULLUP® adjustable juxtacortical fixation system

The PULLUP® system provides simplicity and reproducibility in ACL reconstruction procedures thanks to its unique adjustable size during surgery and to an instrumentation compatible with single semitendinosus tendon harvest as well as classic soft tissue transplants. Discover also the new adapted version for BTB graft : the PULLUP® BTB. PULLUP® implants are made of titanium alloy and premounted sutures, available in two designs depending on the tunnel diameter.

PULLUP®

PULLUP® XL

### Pullup system:

PULLUP® for  $\varnothing$  4.5 mm cortical tunnel - PULLU01201  
 PULLUP XL for  $\varnothing$  5 to 10 mm cortical tunnel - PULXL01202

## PULLUP® BTB: Adjustable juxta-cortical fixation for bone-tendon-bone grafts :

PULLUP® BTB PULLUP® XL BTB

### Adjustable juxta-cortical fixation for bone-tendon-bone grafts :

PULLUP® BTB for  $\varnothing$  4.5 mm cortical tunnel - PULLUK1201  
 PULLUP® XL BTB for  $\varnothing$  5 to 10 mm cortical tunnel - PULXLK1202

## PULLUP® CLIP et PULLUP® TEX CLIP : Connectable plates

PULLUP® CLIP

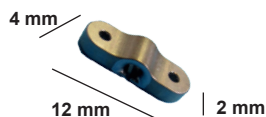

For cortical tunnels with  $\varnothing$  4.5 mm

PULLUP® XL CLIP

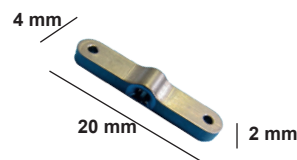

For cortical tunnels with  $\varnothing$  from 5 to 10 mm

PULLUP® TEX CLIP

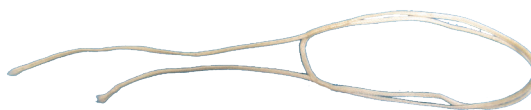

PULLUP® TEX CLIP - Loop only - PULL00LOOP  
 PULLUP® CLIP - Connectable plate for  $\varnothing$  4.5 mm cortical tunnel PULL0CT201  
 PULLUP® XL CLIP - Connectable plate for  $\varnothing$  5 to 10 mm cortical tunnel - PULXLCT202

# BTLOOP® : Adjustable juxta-cortical fixation for bone-tendon-bone grafts

## BTLOOP®

## BTLOOP® XL

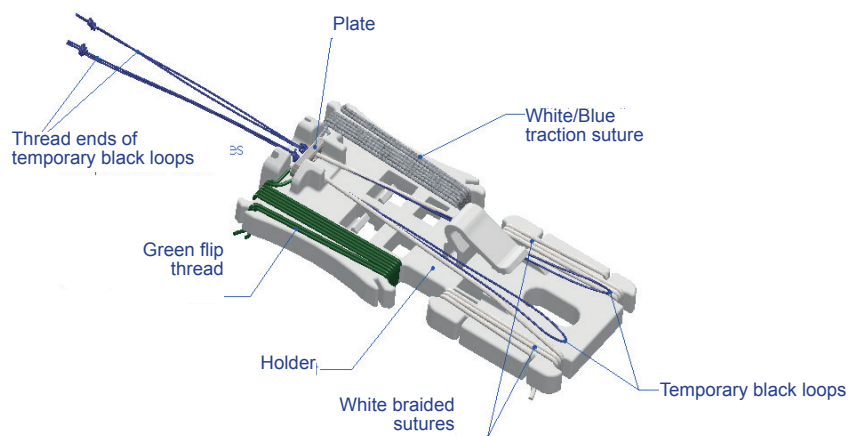

BTLOOP® - Adjustable fixation system for ligament reconstruction (BTB technique) in cortical tunnel Ø 4.5 mm - BTB0001709  
 BTLOOP® XL- Adjustable fixation system for ligament reconstruction (BTB technique) in cortical tunnel Ø 5 to 10 mm - BTBXL01709

### PULLUP® instruments



**Ø 4.5 mm cannulated drill bit**  
 PULL000255

**Ø 4.5 mm full drill bit**  
 LIG9045OR

**Cutting pliers**  
 PULL000219

### GraftTech® preparation station

The GraftTech® preparation station enables to facilitate soft tissue graft preparation, particularly for PULLUP® constructs. It is composed of a regular base and optional add-ons depending of the type of graft to be prepared.

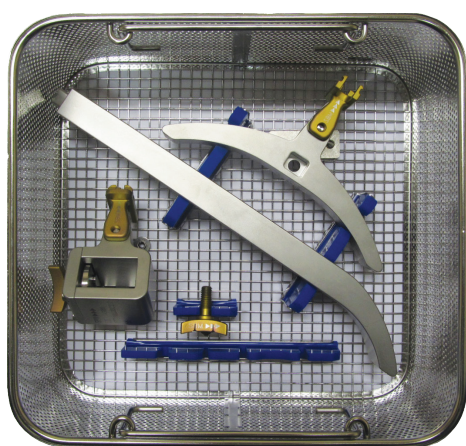

**GraftTech® preparation station base instrumentation  
 mounted with brackets**  
 (including stainless steel basket and lid)

PULLTAB000

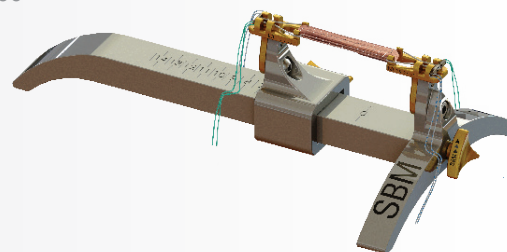

**Options for GraftTech® preparation station**

**Bracket for GraftTech® holder** PULL00G217  
**Bracket for GraftTech® slider** PULL00H217

# GraftTech®

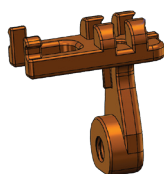

## POWERTEX® Suture loaded with needle

The POWERTEX® suture loaded with needle can be used during ACL reconstruction to suture a single semitendinosus tendon harvest as well as a classic soft tissue transplants. Made up of a semicircular needle and size USP #2 / Length 90 mm UHMWPE (Ultra High Molecular Weight PolyEthylene) braid, POWERTEX® sutures are incredibly strong latest-generation sutures.

# POWERTEX®

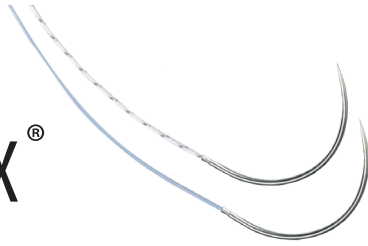

### UHMWPE POWERTEX® Suture loaded with needle

BLUE - SUTRPBLAG1

BLACK/WHITE - SUTRPBNAG1

## Common instruments for ligament reconstruction

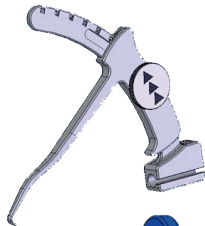

### Evolution Tibial aiming device

LIG9000214



### Guide pin sleeve D4.5 for tibial evolution aiming device

LIG9000215



### Guide pin sleeve D2.5 for tibial evolution aiming device

LIG9000264



### Stopper

LIG9000051



### Cannulated drill bit (long flute) L=60 mm:

Ø 6 mm - LIG9006289

Ø 7 mm - LIG9007289

Ø 8 mm - LIG9008289

Ø 9 mm - LIG9009289

Ø 10 mm - LIG9010289

Ø 11 mm - LIG9011289

### Guide pin (K-Wire) Ø 2.5 mm for drill bits

LIG9125300-01 (x1) / LIG9125300-01 (x5) / LIG9125300-01 (x10)

### Rigid guide pin:

Ø 0.9 mm for Ø 6, 7, 8 mm screwdriver

Lg 300 mm

LIG9109300-01 (x1) / LIG9109300-05 (x5) / LIG9109300-10 (x10)

Lg 400 mm

LIG9109400-01 (x1) / LIG9109400-05 (x5) / LIG9109400-10 (x10)

Ø 1.4 mm for Ø 9, 10, 11 mm screwdriver

Lg 300 mm

LIG9114300-01 (x1) / LIG9114300-05 (x5) / LIG9114300-10 (x10)

Lg 400 mm

LIG9114400-01 (x1) / LIG9114400-05 (x5) / LIG9114400-10 (x10)

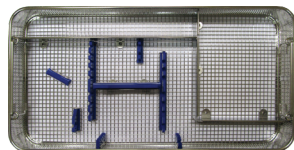

### LIGAFIX® - PULLUP® stainless steel basket with silicones

PULLIGPA02



### Outside-Inside instrument (femoral approach)

#### Evolution Out-In femoral aiming device

LIG90002014

#### Guide pin sleeve for Evolution Out-In femoral aiming device

LIG9000211

### LIGAFIX® complete Outside Inside instrumentation set

LIG90DD000

### Blind Tunnel instruments (femoral approach)

#### Eyelet pin L 400 mm

LIG9000041-01 (x1) / LIG9000041-05 (x5) / LIG9000041-10 (x10)

#### Eyelet pin L 300 mm

LIG9000031-01 (x1) / LIG9000031-05 (x5) / LIG9000031-10 (x10)

#### Pistol-grip femoral aiming device:

Ø 9 mm - LIG9009B45

Ø 10 mm - LIG9010B45

### LIGAFIX® complete Blind Tunnel instrumentation set

LIG90TB000



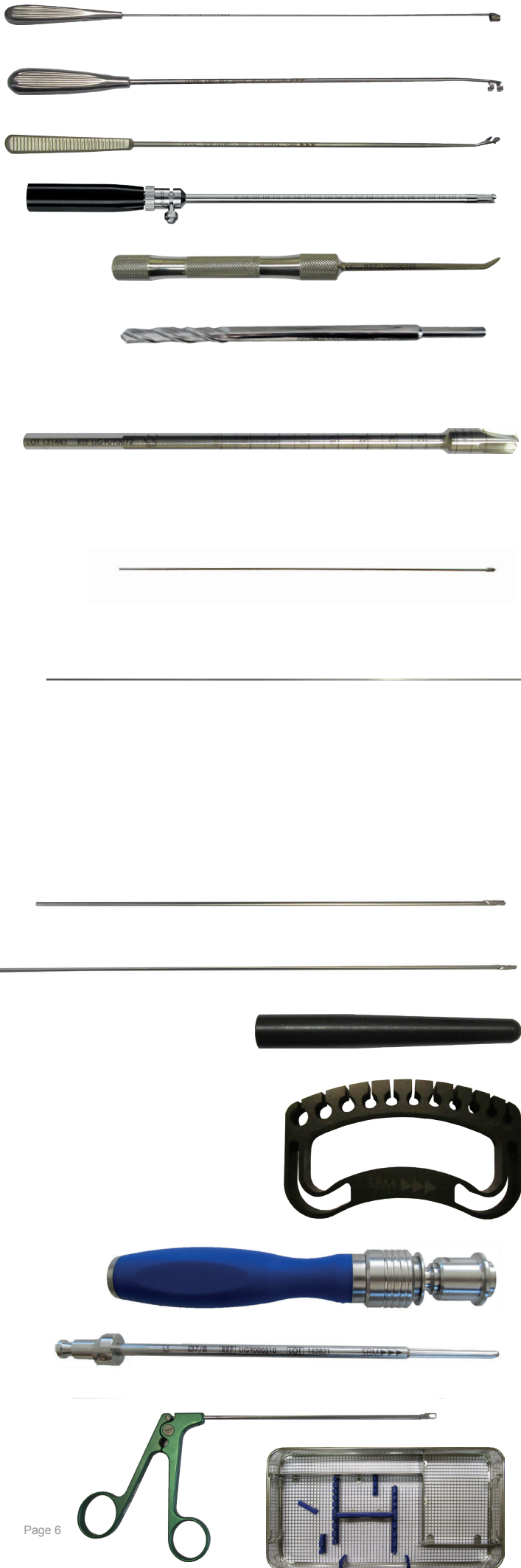

**Optional instruments**

**SBM closed stripper**

LIG90FSTRI

**SBM open stripper**

LIG90OSTRI

**SN-SBM stripper**

LIG9013554

**WOLF-SBM stripper**

8866.951

**Chondral pick**

LIG9000190

**Half-size Cannulated drill bit (long flute) L=60 mm:**

- Ø 6.5 mm - LIG9065289
- Ø 7.5 mm - LIG9075289
- Ø 8.5 mm - LIG9085289
- Ø 9.5 mm - LIG9095289
- Ø 10.5 mm - LIG9105289

**Routers:**

- |                       |                        |
|-----------------------|------------------------|
| Ø 6 mm - LIG9060072   | Ø 9 mm - LIG9090072    |
| Ø 6.5 mm - LIG9065072 | Ø 9.5 mm - LIG9095072  |
| Ø 7 mm - LIG9070072   | Ø 10 mm - LIG9010072   |
| Ø 7.5 mm - LIG9075072 | Ø 10.5 mm - LIG9010572 |
| Ø 8 mm - LIG9080072   | Ø 11 mm - LIG9011072   |
| Ø 8.5 mm - LIG9085072 |                        |

**Lanceolate Rigid guide pin L 360 mm**

LIG9000U36-01 (x1) / LIG9000U36-05 (x5) / LIG9000U36-10 (x10)

**Superelastic/Nitinol wire - diam. 0.8 mm**

Ø 6, 7, 8 mm screws screwdriver

Lg 300 mm

LIG9008300-01 (x1) / LIG9008300-05 (x5) / LIG9008300-10 (x10)

Lg 400 mm

LIG9008400-01 (x1) / LIG9008400-05 (x5) / LIG9008400-10 (x10)

**Superelastic/Nitinol wire - diam. 1.4 mm**

Ø 9, 10, 11 mm screws screwdriver

Lg 300 mm

LIG9014300-01 (x1) / LIG9014300-05 (x5) / LIG9014300-10 (x10)

Lg 400 mm

LIG9014400-01 (x1) / LIG9014400-05 (x5) / LIG9014400-10 (x10)

**Guide pin (K-Wire) Ø 2.4 mm for drill bits**

Lg 300 mm

LIG9M22300-01 (x1) / LIG9M22300-05 (x5) / LIG9M22300-10 (x10)

**Eyelet pin Ø 2.4 mm for drill bits**

Lg 360 mm

LIG9M00041-01 (x1) / LIG9M00041-05 (x5) / LIG9M00041-10 (x10)

**PULLUP® stopper**

LIG9000267

**Graft gauge - half sizes**

LIG9000266

**LIGAFIX® ratchet screwdriver handle**

LIG9000312

**LIGAFIX® ratchet screwdriver rod**

- Ø 6 mm - LIG9000317
- Ø 7/8 mm LIG9000310
- Ø 9/10/11 mm - LIG9000311

**LIGAFIX® ratchet tap rod**

- Ø 6 mm - LIG9000318
- Ø 7/8 mm LIG9000319
- Ø 9/10/11 mm - LIG9000320

**Suture retriever pliers**

LIG906012T

**LIGAFIX® - PULLUP® stainless steel basket lid**

PULLIGPA01



# Osteotomies around the knee

## OTIS® wedges

OTIS® wedges are bioabsorbable anatomically-shaped implants designed for Opening Wedge High Tibial Osteotomy. Made of synthetic Tricalcium Phosphate ( $\beta$ -TCP), OTIS® wedges are available in different porosities: 30% providing a high mechanical strength and 50% favoring a faster resorption. <sup>6, 13, 14, 16, 17</sup>

OTIS®  
OTIS 50®

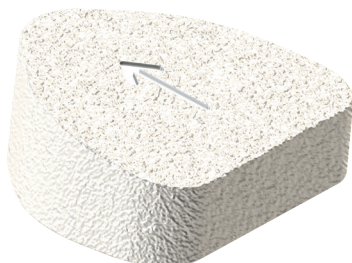

### OTIS® - 30% porosity, height:

6 mm - P822365222  
7 mm - P822365224  
8 mm - P822365226  
9 mm - P822365228  
10 mm - P822365230  
11 mm - P822365232  
12 mm - P822365234  
13 mm - P822365236  
14 mm - P822365238  
15 mm - P822365240

### OTIS 50® - 50% porosity, height:

6 mm - P822667222  
7 mm - P822667224  
8 mm - P822667226  
9 mm - P822667228  
10 mm - P822667230  
11 mm - P822667232  
12 mm - P822667234  
13 mm - P822667236  
14 mm - P822667238  
15 mm - P822667240

## OTIS® instrumentation for High Tibial Osteotomy

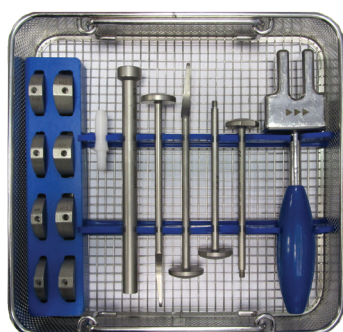

### OTIS® one-piece metallic trial implant - height:

6 mm - EVO90FAH06  
7 mm - EVO90FAH07

### OTIS® metallic trial implant - height:

8 mm - EVO90FAH08  
9 mm - EVO90FAH09  
10 mm - EVO90FAH10  
11 mm - EVO90FAH11  
12 mm - EVO90FAH12  
13 mm - EVO90FAH13  
14 mm - EVO90FAH14  
15 mm - EVO90FAH15

### Handle for OTIS® metallic trial implants (x2) EVO90FAMAN

### Slotted hammer for OTIS® metallic trial implants EVO90FAMAR

### OTIS® impactor:

tip - EVO9069444  
body - EVO9069446

### OTIS® stainless steel basket with silicone holders EVO90FA222

### OTIS® complete instrumentation set for HTO EVO90FA500

## OTIS-C-PLUS® plates and screws

OTIS-C-PLUS® is an anatomically-shaped osteosynthesis designed for Opening Wedge High Tibial Osteotomy. Designed for patients with a high Body Mass Index, the plate and screws are made of stainless steel providing a high mechanical resistance while ensuring easier removal compared to other materials. OTIS-C-PLUS® a low-profile compressive plate: the screws are pre-guided to compress the wedge in order to promote bone fusion.

OTIS-C-PLUS®



### OTIS-C-PLUS® plate:

left - EVO9067722

right - EVO9067522

### OTIS® self-tapping locking screw ø 6.5 mm, length:

27 mm - EVO9066027

30 mm - EVO9066030

33 mm - EVO9066033

36 mm - EVO9066036

39 mm - EVO9066039

42 mm - EVO9066042

45 mm - EVO9066045

50 mm - EVO9066050

55 mm - EVO9066055

60 mm - EVO9066060

65 mm - EVO9066065

70 mm - EVO9066070



## OTIS-C-PLUS® instrumentation for High Tibial Osteotomy

Note: The OTIS-C-PLUS® instrumentation includes OTIS instruments



### ø 3 mm drill for temporary screw

EVO9035100



### ø 3.5 mm round-headed temporary screw (x2)

EVO9069A45



### Plate twister

EVO9069622



### Drill guide, diameter:

ø 3.5 mm - EVO9069428

ø 4.5 mm - EVO9069430



### Drill L195 mm, diameter:

ø 3.5 mm - EVO9069432

ø 4.5 mm - EVO9069434



### Depth gauge

EVO9069438



### Countersink bit

EVO9040203



### ø 3.5 mm hexagonal screwdriver

EVO9069436

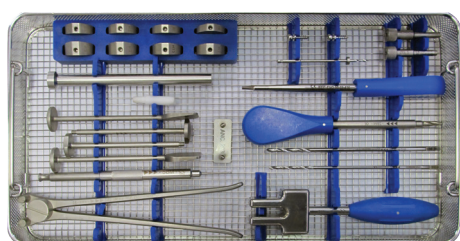

### OTIS-C-PLUS® stainless steel basket with silicone holders

EVO90FA700

### OTIS-C-PLUS® complete instrumentation set for HTO

EVO90FA800



## OTIS-F® plates and screws

OTIS-F® is an anatomically-shaped osteosynthesis designed for Distal Femoral Osteotomies. Versatile, the plate and screws are made of stainless steel providing high mechanical resistance while ensuring easier removal compared to other materials. OTIS-F® has low-profile dimensions and is adapted to the bone density of the femur with three types of screws to ensure proper fixation. The three compressive holes allow compression for subtraction osteotomies and normal fixation for addition osteotomies. <sup>13, 14, 16, 17</sup>

OTIS-F®



### OTIS-F® plate:

lateral right / medial left - EVO9067822  
lateral left / medial right - EVO9067922

### OTIS® self-tapping locking screw ø 6.5 mm, length:

55 mm - EVO9066055  
60 mm - EVO9066060  
65 mm - EVO9066065  
70 mm - EVO9066070  
75 mm - EVO9066075  
80 mm - EVO9066080



## OTIS-F® instrumentation for Distal Femoral Osteotomy

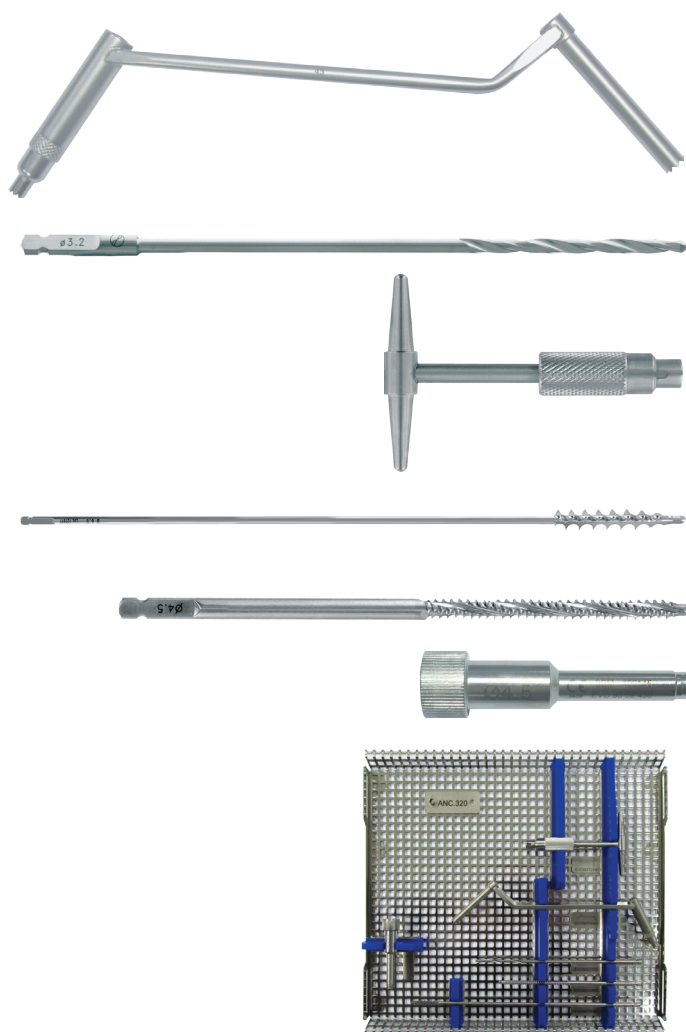

### OTIS-F® AO drill guide: ø 3.2 mm & ø 4.5 mm EVO90T4000

### OTIS-F® AO ø 3.2 mm drill - length 145 mm EVO900T878

### Handle for OTIS-F® AO tap EVO90T3741

### OTIS-F® AO tap ø 6.5 mm EVO90T8086

### OTIS-F® AO tap ø 4.5 mm EVO900T868

### OTIS-F® ø 4.5 mm drill guide EVO9069430

### OTIS-F® in-lay with silicone holders EVO9080000

### Complete OTIS-F® in-lay for DFO EVO9000000

## Extraction kit for OTIS® plates and screws

Removing OTIS® plates can be achieved using the regular OTIS screwdriver, the extraction kit can eventually be used to remove broken screws.

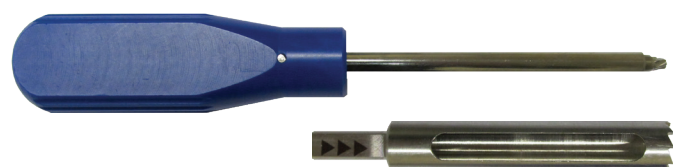

### Screwdriver for OTIS® screws extraction EVO9069439

### Trephine for OTIS® screw extraction EVO9069T65

Note: The OTIS-F® plate includes locations for receiving AO type screws, ø 4.5mm for cortical and ø 6.5 mm for cancellous bone (according to the standards in force). These screws are not supplied by SBM.

# Rotator Cuff Repair

## FIXIT® and FIXIT® KNOTLESS : pre-loaded and knotless suture anchor

FIXIT® is a line of ready-to-use anchors for tendinous tissue fixation in arthroscopic rotator cuff repair. Available in three different sizes, and both with sutures and knotless versions, this system was designed to be quick and easy to use.

**FIXIT®**

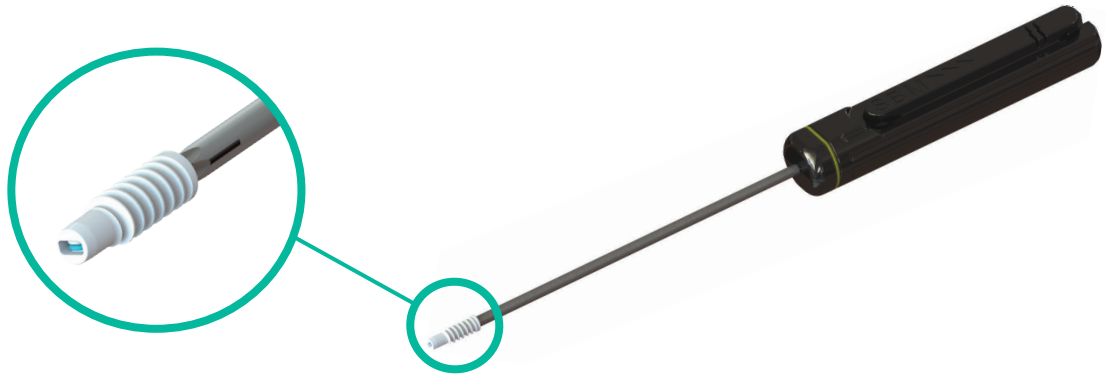

### FIXIT® pre-loaded suture anchor:

FIXIT® ø 4.5 mm threaded anchor mounted on screwdriver - EPA0047CLA

FIXIT® ø 5.5 mm threaded anchor mounted on screwdriver - EPA0055CLA

FIXIT® ø 6.5 mm threaded anchor mounted on screwdriver - EPA0065CLA

**FIXIT®**  
Knotless

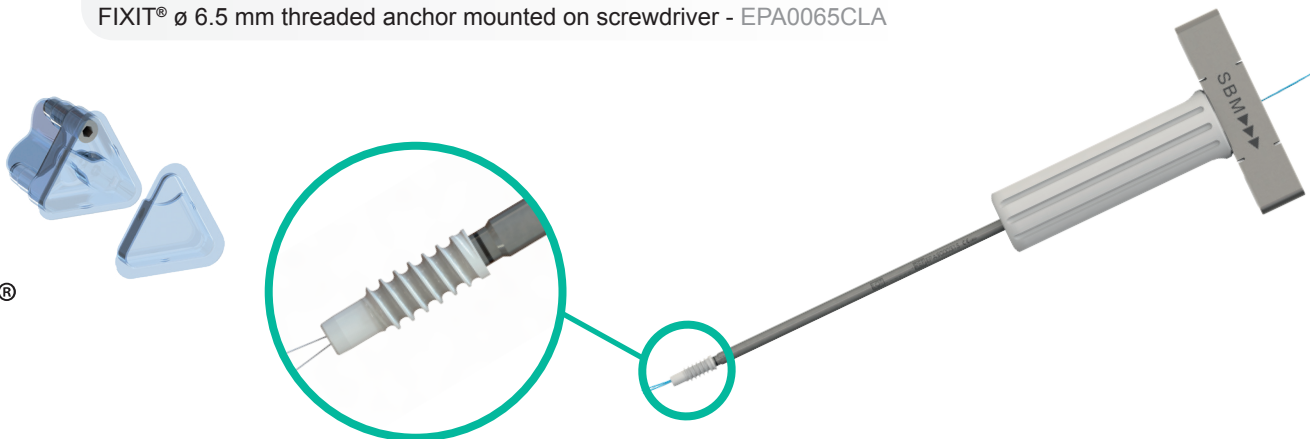

### FIXIT® KNOTLESS suture anchor:

FIXIT® knotless threaded anchor single interference - Ø 4,5 - EPAV245KNO

FIXIT® knotless threaded anchor single interference - Ø 5,5 - EPAV255KNO

FIXIT® knotless threaded anchor single interference - Ø 6,5 - EPAV265KNO

**POWERTAPE®**  
Polyethylene sutures

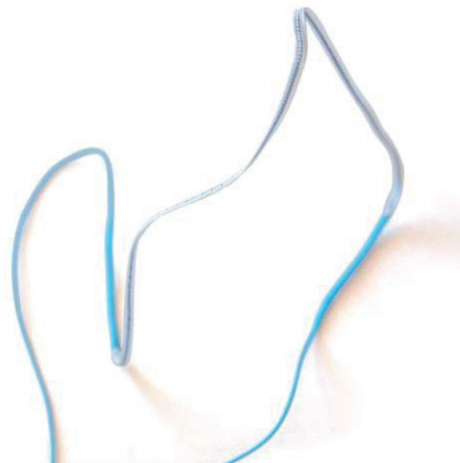

- ▶ Size USP 2 / Thickness 5
- ▶ Total length: 99 cm
- ▶ Width of tape: 2 mm
- ▶ Length of tape: 19 cm

### Powertape® non-absorbable surgical flat suture for rotator cuff repair:

Powertape® non-absorbable surgical flat suture - BLUE/BLUE W 2mm L 99 cm - TAPRPBB001

Powertape® non-absorbable surgical flat suture - WHITE/BLACK W 2mm L 99 cm - TAPRPBN001

## FIXIT® instrumentation for rotator cuff repair



Punch tap  
Size 4.5 - EPA9000240



Punch tap  
Sizes 5.5/6.5 mm - EPA9000241



FIXIT® mallet  
EPA9000247



Tissue Grasper  
EPAGR00074



Penetrating Grasper 30° Up  
EPAGR00174



Clever Hook Right  
328332bs



Clever Hook Left  
328342bs



Suture Manipulator Grasper  
EPAGR00274



Suture Cutter  
231200BS



Knot pusher  
EPAKN00074

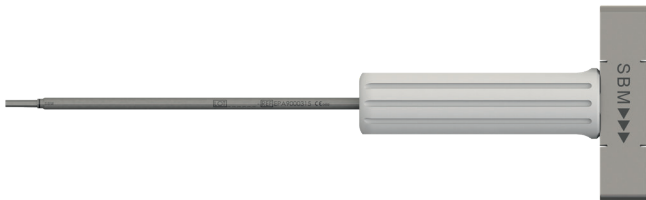

FIXIT® knotless screwdriver  
**NOT DISPOSABLE**  
EPA9000315



Suture retriever pin (x2)  
**NOT DISPOSABLE**  
EPA9000303

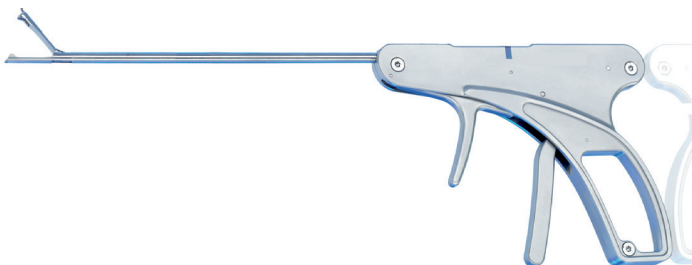

### Optional instrument

Suture passer automatic Grasper  
SMI-02AP

Box of 5 automatic grasper disposable Needles  
SMI-02D

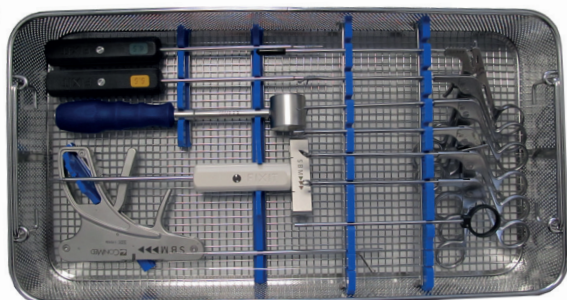

Complete FIXIT® basket - 1st + 2nd row with automatic grasper  
EPA9000004



# Bone void filling

## BIO 1® bioabsorbable implants (β-TCP)

BIO 1® are high purity Tricalcium Phosphate (β-TCP) implants that are ready to use as cancellous or cortico-cancellous bone. Synthetic, bioactive and bioabsorbable, this range is perfectly safe for common bone void filling procedures and promotes bone growth thanks thanks to its osteoconductive properties. <sup>3, 4, 5, 6, 8, 9, 11</sup>

# BIO 1®

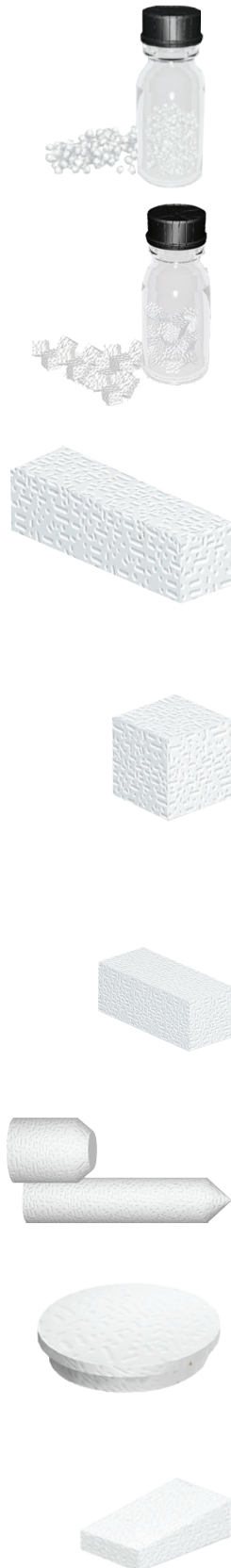

### Granules:

- ø 1 mm (0.6 cc) - P822692240
- ø 1 mm (2 cc) - P822692243
- ø 1 mm (5 cc) - P822692244
- ø 1 mm (15 cc) - P822692246
- ø 1.5 mm (5 cc) - P822692444
- ø 1.5 mm (15 cc) - P822692446
- ø 3 mm (5 cc) - P822692644
- ø 3 mm (15 cc) - P822692646

### Macro-porous cubes:

- 4 x 4 x 4 mm (15 cc) - P822893229
- 4 x 4 x 4 mm (30 cc) - P822893233
- 4 x 4 x 4 mm (45 cc) - P822893232

### Sticks:

- 3 x 3 x 10 mm (x 10) - P822634240
- 5 x 5 x 10 mm (x 5) - P822634440
- 5 x 5 x 10 mm (x 10) - P822634442
- 5 x 5 x 10 mm (x 20) - P822634441
- 5 x 5 x 20 mm (x 1) - P822634446
- 5 x 5 x 20 mm (x 6) - P822634450
- 5 x 5 x 20 mm (x 10) - P822634444
- 5 x 5 x 20 mm (x 20) - P822634445

### Cubes:

- 5 x 5 x 5 mm (x 1) - P822693210
- 5 x 5 x 5 mm (x 2) - P822693220
- 5 x 5 x 5 mm (x 5) - P822693221
- 5 x 5 x 5 mm (x 10) - P822693222
- 7 x 7 x 7 mm (x 1) - P822693420
- 7 x 7 x 7 mm (x 2) - P822693421
- 7 x 7 x 7 mm (x 5) - P822693422
- 10 x 10 x 10 mm (x 1) - P822693620
- 10 x 10 x 10 mm (x 2) - P822693622
- 10 x 10 x 10 mm (x 10) - P822693624

### Blocks:

- 10 x 10 x 25 mm (x 1) - P822694444
- 30 x 20 x 10 mm (x 1) - P822374400

### Cylinders:

- ø 6 mm / L 25 mm (x 2) - P822441442
- ø 6 mm / L 25 mm (x 4) - P822441444
- ø 8 mm / L 10 mm (x 3) - P822661222

### Trephine hole filling:

- ø 10 mm (x 2) - P822311244
- ø 10 mm (x 3) - P822311245
- ø 12 mm (x 2) - P822311444
- ø 12 mm (x 3) - P822311445
- ø 14 mm (x 2) - P822311644
- ø 14 mm (x 3) - P822311645

### Anatomically-shaped implants:

- Ankle arthrodesis 30 x 25 x 7 x 3 mm (x 1) - P822375602
- Metatarsian osteotomy 15 x 10 x 4 x 2 mm (x 1) - P822375000
- Patellar filling 10 x 10 x 6 mm (x 1) - P822694220



## Bibliography

- 1 **ri-calcium phosphate ceramics and Allografts as Bone Substitutes for postero-lateral spine fusion in Idiopathic Scoliosis : Comparative clinical results at 4 years.**  
J-C. Le Huec, E. Lesprit, C. Delavigne, D. Clément, D. Chauveaux, A. Le Rebeller.  
*Acta Orthopédica Belgica*, 1997, 63 (3), 202-11.
- 2 **Evolution of the local calcium content around irradiated  $\beta$ -TCP ceramics implants : In-vivo study in the rabbit.**  
J-C. Le Huec, D. Clément, B. Brouillaud, N. Barthe, B. Dupuy, B. Foliguet, B. Basse-Cathalinat.  
*Biomaterials*, 18, 733-738, 1998.
- 3 **Cellular biocompatibility and compressive strength of macroporous  $\beta$ -tricalcium phosphate ceramics.**  
M. Sous, R. Bareille, A. Rouais, D. Clément, J. Amédée, B. Dupuy, Ch. Baquey.  
*Biomaterials*, 19, 2147-2153, 1998.
- 4 **The use of Calcium Phosphates, their biological properties.**  
J-C. Le Huec, D. Clément, E. Lesprit, J. Faber.  
*European Journal of Orthopaedic surgery and traumatology*, 10, 223-229, 2000.
- 5 **In vivo testing of a new in situ setting  $\beta$ -tricalcium phosphate cement for osseous reconstruction.**  
C. Niedhart, U. Maus, E. Redmann, C.H. Siebert.  
*J Biomed Mater Res* 55: 530–537, 2001
- 6 **Use of  $\beta$ -Tricalcium Phosphate in foot and ankle surgery : a report of 20 cases.**  
L. Galois, D. Mainard, F. Pfeffer, R. Traversari, J-P Delagoutte.  
*Foot and Ankle surgery*, 7, 217-227, 2001.
- 7  **$\beta$ -Tricalcium Phosphate ceramic as a bone substitute in orthopaedic surgery.**  
L. Galois, D. Mainard, J-P Delagoutte.  
*International Orthopaedics (SICOT)*, 26, 109-115, 2002.
- 8 **Kapandji pinning and tuberosities fixation of three- and four-part fractures of the proximal humerus.**  
Bonnevialle N., Ibnoukatib A., Mansat P., Bonnevialle P.  
*Int Orthop.* 2013 Oct;37(10):1965-71. doi: 10.1007/s00264-013-1926-1. Epub 2013 May 21.
- 9 **Pulmonary function after less invasive anterior instrumentation and fusion for idiopathic thoracic scoliosis.**  
Huiteima GC., Jansen RC., Dompeling E., Willems P., Punt I., van Rhijn LW.  
*Scoliosis.* 2013 Aug 21;8(1):14. doi: 10.1186/1748-7161-8-14.
- 10  **$\beta$ -Tricalcium Phosphate ceramic as a bone substitute in orthopaedic surgery,**  
GALOIS L., MAINARD D., DELAGOUTTE J-P.  
*International Orthopaedics (SICOT)*, 26, 109-115, 2002.
- 11 **Computer-assisted high tibial and double-level osteotomies for genu varum deformity,**  
SARAGAGLIA D., ROBERTS J., RUBENS-DUVAL B.  
*Techniques in Knee Surgery*, 5(4) :212-217, 2006.
- 12 **Opening-wedge High Tibial Osteotomy with a Tricalcium Phosphate Wedge**  
SARABIA-CONDESA J.M., VILLAESCUSA-MARINA S., HERNANDEZ-GARCIA C., MARTIN-FERRERO M.A.  
*Rev Ortop Traumatol (Madr.)*. 2007;51:182-7
- 13 **Resorbability of rigid beta-tricalcium phosphate wedges in open-wedge high tibial osteotomy. A retrospective radiological study,**  
KRAAL T., MULLENDER M., DE BRUINE J.H.D., REINHARD R., DE GAST A., KUIK D.J., VAN ROYEN B.J.  
*The Knee*, 15, 201-205, 2008.
- 14 **Correction accuracy and collateral laxity in open versus closed wedge high tibial osteotomy. A one-year randomised controlled study.**  
GAASBEEK R., NICOLAAS L., RIJNBERG W., VAN LOON C., VAN KAMPEN A.  
*International Orthopaedics (SICOT)* (2010) 34:201–207 DOI 10.1007/s00264-009-0861-7
- 15 **Outcome of opening wedge high tibial osteotomy augmented with a Biosorb wedge and fixed with a plate and screws in 124 patients with a mean of ten years follow-up,**  
SARAGAGLIA D., BLAYSAT M., INMAN D, MERCIER N.  
*Int Orthop.* 2010. DOI 10.1007
- 16 **Results of forty two computer-assisted double level osteotomies for severe genu varum deformity,**  
SARAGAGLIA D, BLAYSAT M, MERCIER N., GRIMALDI M.  
*Int Orthop.* (2012) 36:999–1003
- 17 **A retrospective analysis of medial open wedge high tibial osteotomy for varus osteoarthritic knee.**  
Vaishya R.  
*Indian J Orthop.* 2013 Mar;47(2):215. doi: 10.4103/0019-5413.108936., 2013
- 18 **Role of computer-assisted surgery in osteotomies around the knee.**  
D. Saragaglia, Chedal-Bornu, Rouchy, Rubens-Duval, Mader, Pailhé  
*Knee Surg Sports Traumatol Arthrosc* (2016) 24: 3387. <https://doi.org/10.1007/s00167-016-4302-z>
- 19 **Prospective study of the anterior cruciate ligament reconstruction associated with high tibial opening wedge osteotomy in knee arthritis associated with instability.**  
Raju Vaishya, Vipul Vijay, Gyanendra Kumar Jha, Amit Kumar Agarwal  
*J Clin Orthop Trauma.* 2016 Oct-Dec;7(4):265-271. Epub 2016 Jun 24.
- 20 **Better clinical results after closed- compared to open-wedge high tibial osteotomy in patients with medial knee osteoarthritis and varus leg alignment.**  
van Egmond N., van Grinsven S., van Loon CJ., Gaasbeek RD., van Kampen A.  
*Knee Surg Sports Traumatol Arthrosc.* 2016 Jan;24(1):34-41. doi: 10.1007/s00167-014-3303-z. Epub 2014 Sep 13.
- 21 **Gait analysis following medial opening-wedge high tibial osteotomy.**  
Morin V., Pailhé R., Duval BR., Mader R., Cognault J., Rouchy RC., Saragaglia D.  
*Knee Surg Sports Traumatol Arthrosc.* 2017 Mar 1. doi: 10.1007/s00167-017-4421-1.
- 22 **Computer-assisted osteotomies for genu varum deformity: which osteotomy for which varus?**  
Dominique Saragaglia, Numa Mercier, and Pierre-Emmanuel Colle  
*Int Orthop.* 2010 Feb; 34(2): 185–190. Published online 2009 Mar 21. doi: 10.1007/s00264-009-0757-6



- 23 **Clinical and Functional Outcomes of Anterior Cruciate Ligament Reconstruction at a Minimum of 2 Years Using Adjustable Suspensory Fixation in Both the Femur and Tibia. A Prospective Study.**  
Philippe Colombet, MD, Mo Saffarini, MEng, and Nicolas Bouguennec, MD  
The Orthopaedic Journal of Sports Medicine, 6(10), 2325967118804128, DOI: 10.1177/2325967118804128, 2018
- 24 **Complications et échecs des reconstructions du LCA par DT4 et fixations de suspension réglables : suivi prospectif de 1148 patients**  
Philippe Colombet, M.D. and Nicolas Bouguennec  
Revue de Chirurgie Orthopédique et Traumatologique, Volume 104, Issue 8, Supplement, December 2018, Page S92
- 25 **Anterior Laxity at 2 Years After Anterior Cruciate Ligament Reconstruction Is Comparable When Using Adjustable-Loop Suspensory Fixation and Interference Screw Fixation**  
Achilleas Boutsiadis, MD, PhD, Jean-Claude Panisset, MD, Brian M. Devitt, MD, FRCS, FRACS, Frédéric Mauris, MD, Renaud Barthelemy, MD, and Johannes Barth, MD  
The American Journal of Sports Medicine; 1–10 ; DOI: 10.1177/0363546518784005, 2018
- 26 **Suspensory fixation device for use with Bone Patellar Tendon Bone grafts**  
Philippe Colombet, M.D. and Nicolas Bouguennec  
Arthrosc Tech. 2017 Jun; 6(3): e833–e838. Published online 2017 Jun 19. doi: 10.1016/j.eats.2017.02.013, 2017
- 27 **Adjustable button devices for all arthroscopic posterior cruciate ligament reconstruction**  
Paul Brossard, M.D., Achilleas Boutsiadis, M.D., Ph.D., Jean-Claude Panisset, M.D., Frédéric Mauris, M.D., and Johannes Barth, M.D.  
Arthrosc Tech. 2017 Aug; 6(4): e979–e985. Published online 2017 Jul 10. doi: 10.1016/j.eats.2017.03.010, 2017
- 28 **Minimally Invasive combined anterior and anterolateral stabilization of knee using hamstring tendons and adjustable loop suspensory fixation device Surgical technique**  
Achilleas Boutsiadis, M.D., Ph.D., Paul Brossard, M.D., Jean-Claude Panisset, M.D., Nicolas Graveleau, M.D., and Johannes Barth, M.D.  
Arthrosc Tech. 2017 Apr; 6(2): e419–e425. Published online 2017 Apr 10. doi: 10.1016/j.eats.2016.10.019, 2017
- 29 **Incorporation of hamstring grafts within the tibial tunnel after anterior cruciate ligament reconstruction**  
Colombet P, Graveleau N, Jambou S.  
Am J Sports Med. 2016 Nov;44(11):2838-2845. Epub, 2016
- 30 **An anterior cruciate ligament reconstruction technique with 4 strand semitendinosus grafts, using outside-in tibial tunnel drilling and suspensory Fixation devices**  
P. Colombet, M.D., and N. Graveleau, M.D.  
Arthrosc Tech. 2015 Sep 28;4(5):e507-11. doi: 10.1016/j.eats.2015.05.014. eCollection, 2015
- 31 **Long term degradation of self reinforced poly levo dextro lactide tcp biocomposite interference screws**  
F. Alan Barber, M.D., and W. D. Dockery, M.D.  
Arthroscopy. 2016 Apr;32(4):608-14. doi: 10.1016/j.arthro.2015.08.037. Epub, 2015
- 32 **Do outcomes of outpatient ACL reconstruction vary with graft type**  
L. Baverela, G. Demeya, G.-A. Odric, P. Leroya, M. Saffarini, D. Dejour  
Orthopaedics & Traumatology: Surgery & Research 101 (2015) 803–806, 2015
- 33 **Suspensory fixation versus novel transverse crosspin for femoral fixation in anterior cruciate ligament reconstruction - TRANSLIG**  
Zehir S&R, Coll.  
Arch Orthop Trauma Surg 134:1579-1585 DOI 10.1007/s00402-014-2062-0 ,2014
- 34 **Are the tubular grafts in the femoral tunnel in an anatomical or isometric position in the reconstruction of medial patellofemoral ligament?**  
NTAGIOPOULOS P-G, SHAMA B., BIGNOZZI S, LOPOMO N., COLLE, F., ZAFFAGNINI S., DEJOUR D.  
International Orthopaedics (SICOT) DOI 10.1007/s00264-013-1938, 2013
- 35 **A new technique in double-bundle anterior cruciate ligament reconstruction using implant-free femoral fixation**  
PRADO R-K, NTAGIOPOULOS P-G, FUCS P-M-B, SEVERINO N-R, DEJOUR D.  
International Orthopaedics, Volume 36, Number 7, 1479-1485, 2012
- 36 **Bone-patellar tendon-bone graft via a single minimally-invasive approach versus a classical approach in anterior cruciate ligament reconstruction**  
IONCU A., MADER R., BONIN N, TERNAMIAN P-J., DEJOUR D.  
Orthopaedics & Traumatology: Surgery & Research 98, 426—431, 2012
- 37 **Knee laxity control in revision Anterior Cruciate Ligament reconstruction versus Anterior Cruciate Ligament reconstruction and lateral tenodesis**  
COLOMBET P.  
The American Journal of Sports Medicine, vol. 39 no. 6 1248-1254, 2011
- 38 **Interest of an osteoconductive material in graft healing of acl reconstruction with the Hamstring Tendon**  
ROBERT H.  
SOFOT 2010
- 39 **Biological performance of a new  $\beta$ -TCP - PLLA composite material for applications in spine surgery: in vitro and in vivo studies**  
AUNOBLE S., CLEMENT D., FRAYSSINET P., HARMAND M-F., LE HUEC J-C.  
Journal of Biomedical Materials Research, Part A, Art. 30749, 1-7, 2006
- 40 **Patellar Tendon Reconstruction Using Hamstring Tendon and Adjustable Suspensory Cortical Fixation**  
Jordan Ovigue, M.D., Nicolas Graveleau, M.D., and Nicolas Bouguennec, M.D.  
Arthroscopy Techniques, Vol -, 2019: pp e1-e5
- 41 **The Migratory Cortical Button: A Rare Case of Hypersensitivity to Titanium after an Anterior Cruciate Ligament Reconstruction**  
Nicolas Bouguennec, MD, Philippe Colombet, MD, Nicolas Graveleau, MD, and Stephane Jambou, MD  
Knee Surg Relat Res. <https://doi.org/10.5792/ksrr.18.072>, pISSN 2234-0726 · eISSN 2234-2451, Published Online: 18 March 2019
- 42 **Tibial slope and medial meniscectomy significantly influence shortterm knee laxity following ACL reconstruction**  
David Dejour · Marco Pungitore · Jeremy Valluy · Luca Nover · Mo Saffarini · Guillaume Demey  
Knee Surgery, Sports Traumatology, Arthroscopy, <https://doi.org/10.1007/s00167-019-05435-0>, 20 February 2019